



**SAFETY RECALL J070 [NHTSA # 17V027]:  
TAKATA PASSENGER AIRBAG**

**SERVICE BULLETIN**

20-APR-17

NO.: 7-127USA

SEC.: RECALL

MKT.: USA

***Jaguar Land Rover North America, LLC has informed the National Highway Traffic Safety Administration (NHTSA) of its intent to perform a voluntary Safety Recall on certain 2009 and 2012 model year Jaguar XF vehicles imported into the United States market. Information relating to this Recall will be posted on the National Highway Traffic Safety Administration website.***

***United States Federal regulations require that retailers must be notified within a reasonable time after the manufacturer decides that a defect that relates to motor vehicle safety or a noncompliance exists.***

***United States Federal law requires retailers to complete any outstanding safety Recall service before a new vehicle is delivered to the buyer or lessee. Violation of this requirement by a retailer could result in a civil penalty of up to \$21,000.00 per vehicle.***

***This Recall Service Bulletin serves as notification to all Jaguar retailers in the United States and Puerto Rico that any affected new vehicles may not be sold and delivered for customer use until the Recall repair is completed.***

***THIS BULLETIN UPDATES 7-121USA***

**DESCRIPTION OF ISSUE**

An issue has been identified on certain vehicles listed within the Affected Vehicle Range. These vehicles are fitted with certain airbag inflators assembled as part of the front passenger airbag modules, and used as original equipment or replacement equipment.

Following the recent Customer Letters sent as part of Safety Recall J070, this interim bulletin is released to support retailers where Customers may have serious concerns following receipt of the initial defect notification letters.

This Recall Action provides for the replacement of the passenger airbag until such time as Customers are notified of the availability of the remedy part. Customers may raise concerns or feel that they cannot continue to use their vehicle in an unrepaired state. Immediate advice to Customers, repeated here for ease of reference, is:

*'Jaguar Land Rover North America is not aware of any case of airbag module rupture on our vehicles. Nonetheless, if you are uncomfortable while waiting for the repair, you may elect to avoid having a passenger sit in the front passenger seat until the recall repair has been performed.'*

**AFFECTED VEHICLE RANGE**

**NOTE: refer to the appendix for the list of states and territories by Zone.**

Certain 2012 model year XF vehicles originally sold, or ever registered, in 'Zone A.'

Additionally, certain 2009 model year XF vehicles, originally sold, or ever registered, in 'Zone B.'

Certain 2009 and 2012 model year Jaguar XF vehicles not originally sold, or ever registered, in either Zones A or B are not subject to this Safety Recall.

XF (X250)

Model Year: ..... 2009

VIN: ..... SAJWA05B09HR00169-SAJWA05B19HR47002

Model Year: ..... 2012

VIN: ..... SAJWA0HE4CMS10154-SAJWA0HB6CLS61361

A total of 8,114 vehicles are potentially involved in the USA and Federalized Territories as listed in the Appendix.

**EFFECT ON VEHICLE OPERATION**

In the event of a crash necessitating deployment of the front passenger airbag, these inflators may rupture due to propellant degradation occurring after long-term exposure to absolute humidity and temperature cycling. An inflator rupture may result in metal fragments striking the vehicle occupants, resulting in serious injury or death.

**SERVICE PROGRAM / REWORK ACTION**

Jaguar Land Rover is currently sourcing replacement parts for this Recall. Parts are expected to be available during quarter 3, 2017. At that time, owners will be notified by mail to take their vehicle to a Jaguar retailer who will replace the front passenger airbag module.

There will be no charge to owners for this action.

**OWNER NOTIFICATION**

Owners received an interim notification by mail in March 2017. They will receive a further notification by mail once a service repair is available. Parts are expected to be available during quarter 3, 2017.

**ACTION TO BE TAKEN**

Where Customers are unwilling to adhere to the above advice, to support Customers and provide reassurance, in the first instance, please make sure that the vehicle is included in Safety Recall J070.

Where the VIN is shown as open, on behalf of the customer, please contact the Customer Relationship Centre (800-452-4827, Option 9) to identify the VIN and customer details. Customers may also contact the Customer Relationship Centre directly to discuss any concerns should they wish to do so.

Once the VIN is confirmed as eligible for J070, the process identified in the Workshop Procedure of the Technical Bulletin noted below is to be followed.

In addition to the above, irrespective of this action, the passenger airbag will be replaced again in the future once the required parts become available. This program has been constructed with the agreement of NHTSA.

Refer to Technical Bulletin J070NAS, *SAFETY RECALL: Takata Passenger Airbag*, for detailed repair instructions.

**PARTS**

**NOTE: when ordering parts, order only the expected percentage demand of parts identified.**

DESCRIPTION	PART NO. / SUNDRY CODE	QTY. / VALUE	EXPECTED PERCENTAGE DEMAND
Passenger airbag module	C2Z32119	1	100
Nut and washer kit	C2P2765	8	100

**NOTE: the serial number (example highlighted in blue) of the new airbag module MUST be recorded on the claim verbatim.**

1. Locate the label on the NEW passenger airbag module.

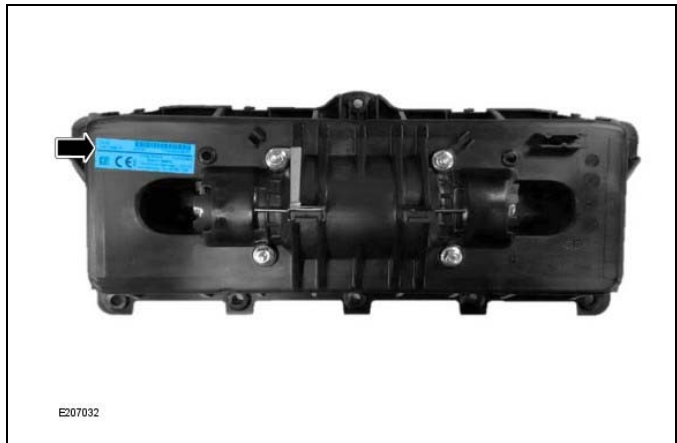

2. Locate the QR code on the NEW passenger airbag module label.



3. Use a smartphone with a QR code scanner to scan the QR code of the NEW front passenger airbag module.
4. Record the NEW passenger airbag module serial number, displayed on the screen, on the claim verbatim.

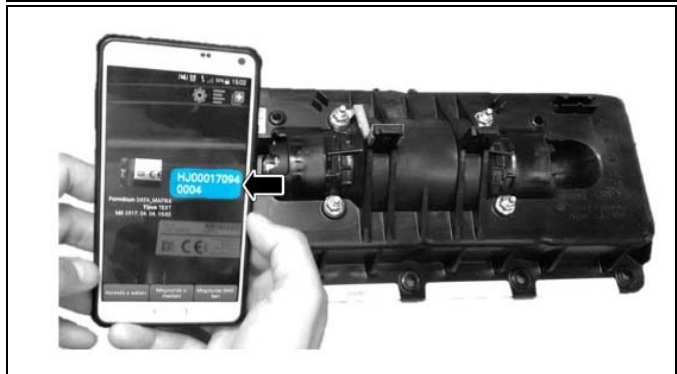

### **SPECIAL DISPLACED PARTS HANDLING PROCEDURE**

#### **All retailers EXCEPT Hawaii, Puerto Rico, and Guam**

Displaced parts require special handling and shipping procedures. The necessary shipping documents are provided with the new airbag.

See the attached file for complete return shipping instructions (all retailers EXCEPT Hawaii, Puerto Rico, and Guam).

#### **Hawaii, Puerto Rico, and Guam retailers ONLY:**

- Contact XPO at [sctakatarestraints\\_international@xpo.com](mailto:sctakatarestraints_international@xpo.com) or 210-250-5039.

- Provide XPO with retailer details (name, address), contact information, and cargo details (number of pieces and weight).

## TOOLS

Refer to the Technical Bulletin referenced above for any required special tools.

## WARRANTY

**NOTE: check DDW to ensure that a vehicle is affected by this program prior to undertaking any rework action.**

**NOTE: the serial number of the new airbag module MUST be recorded on the claim verbatim.**

At the time of confirming a booking for vehicle repair, ensure that **all** outstanding Recall and Service Actions are identified to ensure the correct parts are available and adequate workshop time is allocated for repairs to be completed in one visit.

Warranty claims must be submitted quoting the Program Code together with the relevant Option Code. The SRO and parts information listed is included for information only. The Option Code(s) that allows for the drive in/drive out allowance may only be claimed if the vehicle is brought into the workshop for this action alone to be undertaken.

Warranty claims must be submitted for payment within 30 calendar days of completion of the repair.

Repair procedures are under constant review and therefore times/prices are subject to change; those quoted here must be taken as guidance only. Refer to TOPIx to obtain the latest repair time.

PROGRAM CODE	OPTION CODE	DESCRIPTION	SRO	TIME (HOURS)	PART NO. / SUNDRY CODE	QTY. / VALUE
J070	B	Passenger airbag - Renew	76.73.37	1.90	C2Z32119 C2P2765	1 8
J070	C	Passenger airbag - Renew	76.73.37	1.90	C2Z15835 C2P2765	1 8
		Drive in/drive out	10.10.10	0.20	-	-

*Normal Warranty policies and procedures apply.*

## CUSTOMER RE-IMBURSEMENT FOR PREVIOUS REPAIRS AND RELATED DAMAGE CLAIMS

If a customer has indicated that they have already paid for this concern as a normal retail repair (vehicle outside normal warranty period) prior to the date of their owner notification letter, a copy of the repair invoice must be produced as proof of the repair. The retailer must directly reimburse the customer and a claim for recovery of this cost should be made using the related damage procedure.

Supplementary claims for related damages can only be made once the Recall claim has been paid and accepted. Only repairs performed using approved Jaguar parts are eligible for reimbursement.

Submit claims quoting Program Code '**J070**' by selecting the 'Related Damage' radio button on the claim submission screen. Use Option Code '**X**' as detailed below and enter the cost to be reimbursed against the sundry code of '**ZZZ999**'. All costs are to be entered in local currency.

PROGRAM CODE	OPTION CODE	DESCRIPTION	TIME (HOURS)	SUNDRY ITEM CODE	MISCELLANEOUS EXPENSE (\$)
J070	X	Re-imburement to owner	N/A	ZZZ999	Retailer Entered Value

A copy of the invoice must be appended to the repair order for Warranty Audit purposes and Warranty Specialist review. Enter a brief comment in the 'Technician Comments' field on the claim to itemize and explain the charges.

Only vehicles eligible for this Safety Recall are included in this process. Only one claim per vehicle for related damages will be accepted.

**RETAILER INQUIRIES - J070**

For questions relating to the contents of this publication, please contact:

[recallq@jaguarlandrover.com](mailto:recallq@jaguarlandrover.com).

## **APPENDIX 'A': SAFETY RECALL JO70 - LIST OF STATES/TERRITORIES BY ZONE**

---

### **ZONE A STATES AND TERRITORIES: Hot & Humid**

Alabama, California, Florida, Georgia, Hawaii, Louisiana, Mississippi, South Carolina, Texas, Puerto Rico, American Samoa, Guam, The Northern Mariana Islands (Saipan), the U.S. Virgin Islands

### **ZONE B STATES: Less Hot & Humid**

Arizona, Arkansas, Delaware, District of Columbia, Illinois, Indiana, Kansas, Kentucky, Maryland, Missouri, Nebraska, Nevada, New Jersey, New Mexico, North Carolina, Ohio, Oklahoma, Pennsylvania, Tennessee, Virginia, West Virginia

### **ZONE C STATES: Least Hot & Humid - Jaguar Land Rover has no affected XF vehicles within this Zone at this time**

Alaska, Colorado, Connecticut, Idaho, Iowa, Maine, Massachusetts, Michigan, Minnesota, Montana, New Hampshire, New York, North Dakota, Oregon, Rhode Island, South Dakota, Utah, Vermont, Washington, Wisconsin, Wyoming

## Jaguar Land Rover Service Modules – LTL Shipping Instructions

**NOTE: International and ALL Locations outside of the Continental United States (APAC, EMEA, Mexico, Hawaii, Alaska, Puerto Rico, and US Virgin Islands dealers) CANNOT follow below shipping instructions. Instead, dealerships in these locations MUST contact the following Takata/XPO USA representative directly for shipping instructions:**

Armando Gonzales - Tel: 210-250-5039 or Email: [Armando.Gonzales@email.xpo.com](mailto:Armando.Gonzales@email.xpo.com); [SCTakataRestraints\\_International@XPO.com](mailto:SCTakataRestraints_International@XPO.com)

**NOTE: for Continental US 48-State dealerships, please follow steps 1-7 below.**

**It is recommended that personnel wear gloves when working with these packages to protect against cuts**

### 1a. Shipping Documents - Supplied With New Airbag

a) Return Box Label

- Supplied with each new module and is to be affixed to each return part box.
- (NOTE: some return labels can be found in new module packaging sleeves).



### 1b. Shipping Documents - To Be Obtained From XPO

b) Over-Pack Label

- To be emailed by XPO.
- To be affixed to the outside of each pallet.

c) Bill of Lading

- To be emailed by XPO
- Print 2 copies: 1 for Dealer Records, 1 for LTL Driver.

d) ERG Document

- To be emailed by XPO.
- To be provided by the Dealer to the LTL Driver for each shipment.

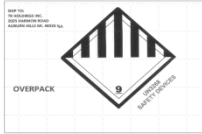

### 2a. Packing Instructions

**\*\*DO NOT DEPLOY THE INFLATOR\*\***

Confirm box is in acceptable condition:

- Box should be in good condition with no visible signs of damage;
- Box should be capable of withstanding additional transportation.

a) Place the tray module in the position shown and then fold the tray.

b) Assemble the box as AB20 (below).

c) Insert the assembled tray into the box.

- Close the box.
- Place the box on a pallet.
- Seven cardboard boxes per layer, four layers per pallet.
- **Pallets are non-stackable!!**



### 2b. Packing Instructions (continued)



### 3. Label Each Box

**\*\*DO NOT DEPLOY THE INFLATOR\*\***

- Hazard Class Labels - Class 9 (pre-printed)
- UN3268 label
- Ship To Address Label to the box
- Do not cover up Class 9 marking

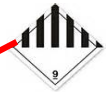

UN 3268 SAFETY DEVICES

### 4. Shipping Instructions - Prepare the Pallet

- Accumulate and palletize kits.
- Arrange modules on pallet.
  - A maximum of 28 modules (boxes) per pallet.
- Shrink-wrap module to pallet.
- Prepare to ship every two weeks.

### 5. Shipping Instructions - Schedule LTL Pickup

- When ready to ship, call XPO at 877-650-3476.
- Have the following information available:
  - Dealer #
  - Quantity of over-packs/pallets
  - Quantity of modules on each pallet
  - Email address where shipping documentation can be received

### 6. Shipping Instructions - Ship

- Give 1 copy of BOL and 1 copy of ERG to Driver.
- Retain 1 copy of BOL for dealership records and archive for at least 2 years.

### 7. Requesting a New Box / Shipping Labels

If a new box, replacement box, or shipping labels are needed, please contact the representative listed below by phone or email to request replacement materials.

Primary Contact: XPO Customer Service Rep - Tel: 210-250-5079

E-Mail: [SCFieldAction.14305@xpo.com](mailto:SCFieldAction.14305@xpo.com)

To help expedite your request, please be prepared to provide the following information:

a) Type of shipping material needed:

- Replacement Box
- Two-Part Return Label
- Bill of Lading
- ERG Form

b) Dealer Shipping Information:

- Contact Name
- Dealer Address
- Phone Number





## IMPORTANT SAFETY RECALL

This notice applies to your vehicle SAJXXXXXXXXXXXXXX

March 2017

### Safety Recall J070: Takata Passenger Airbag

**Vehicle Affected: Jaguar XF**  
**Model Year: 2009; 2012**

**National Highway Traffic Safety Administration (NHTSA) Recall Number: 17V027**

#### Dear Jaguar XF Owner,

This notice is sent to you in accordance with the requirements of the *National Traffic and Motor Vehicle Safety Act*. Jaguar has determined that a defect relating to motor vehicle safety exists in certain 2009 and 2012 model year Jaguar XF vehicles.

Your vehicle is included in this Recall action.

#### What is the concern?

Due to prolonged exposure to combined high heat and humidity, the front passenger airbag module inflator housing may rupture and deploy abnormally in the event of a crash necessitating deployment of the front passenger airbag. In such event, a front passenger airbag module inflator housing rupture could result in metal fragments striking the passenger or other occupants, resulting in serious injury or death.

#### What will Jaguar and your authorized Jaguar retailer do?

Jaguar is carrying out a recall of certain Jaguar XF vehicles within the model years mentioned above. **However, we currently do not have stock of the necessary components to repair your vehicle. Parts are expected to be available by 30 September 2017.**

**When the components become available, you will be notified by a second mailing and instructed to take your vehicle to an authorized Jaguar retailer who will replace the front passenger airbag module.**

There will be no charge for this repair.

#### What should you do?

When you receive a follow-up notice, please contact your authorized Jaguar retailer to schedule an appointment to have Safety Recall 'J070' completed on your vehicle. In the meantime, if you have any questions or concerns, please use the contact information further below.

Jaguar Land Rover North America, LLC  
555 MacArthur Boulevard  
Mahwah, NJ 07430  
[www.jaguarusa.com](http://www.jaguarusa.com)



**How long will it take?**

The work will be carried out as quickly and efficiently as possible in order to minimize inconvenience to customers. It is expected to take approximately two (2) hours, although your retailer may need your vehicle for a longer time. Your retailer can provide you with a better estimate of the overall time for the service visit.

**Attention Leasing Agencies:** Federal regulations require that you forward this recall notification to the lessee within TEN days.

**Moved or no longer own this Jaguar vehicle?**

If you are no longer the owner of this vehicle, Jaguar would greatly appreciate the name and address of the new owner, using the Information Change Form enclosed.

**What should you do if you have further questions?**

Should you have any questions regarding this Safety Recall or need assistance in locating the nearest authorized Jaguar retailer, please contact the Jaguar Customer Relationship Centre at 1-800-4JAGUAR (1-800-452-4827), Option 9, Option 2, and one of our representatives will be happy to assist you.

You may also contact us by email using the following address: [jagweb1@jaguarlandrover.com](mailto:jagweb1@jaguarlandrover.com). Please include your full name, address, and the VIN of your vehicle in your email.

If you have the need to contact Jaguar by mail, please use the following address:

Jaguar Land Rover North America, LLC  
ATTN: Customer Relationship Centre  
555 MacArthur Boulevard  
Mahwah, NJ 07430

If you are having difficulty getting your vehicle repaired in a reasonable time, without charge, or have any additional questions regarding this Safety Recall, you may contact the National Highway Traffic Safety Administration (NHTSA) by writing to:

Administrator, National Highway Traffic Safety Administration  
1200 New Jersey Avenue, SE  
Washington, D.C. 20590

Or you may call the toll-free Vehicle Safety Hotline at 1-888-327-4236 (TTY: 1-800-424-9153), or log on to <http://www.safercar.gov> to submit a complaint electronically.

Jaguar appreciates your confidence in our product and wish to do everything we can retain that confidence. We recognize this service visit may be an inconvenience to you. Jaguar, in cooperation with your authorized Jaguar retailer, will strive to minimize any inconvenience to you caused by this program.

Sincerely,



Peter Pochapsky  
Customer Relationship Centre Manager

## SAFETY RECALL J070: TECHNICAL Q & A

**Main Message: Jaguar 2009 and 2012 Model Year (MY) XF vehicles are equipped with certain Takata airbag inflators (Ammonium Nitrate without desiccant propellant) assembled as part of the front passenger airbag modules, and used as original equipment or replacement equipment.**

**In the event of a crash necessitating deployment of the front passenger airbag, these Takata inflators may rupture due to propellant degradation occurring after long-term exposure to absolute humidity and temperature cycling. An inflator rupture may result in metal fragments striking the vehicle occupants, and could result in serious INJURY or DEATH.**

**Q1 Who do I contact if a member of the press contacts me about this recall?**

**A** Please ensure Press enquiries are referred to the Jaguar Land Rover North America Press Office to the attention of:

**Stuart Schorr**

Vice President, Communications & Public Affairs  
Jaguar Land Rover North America, LLC

[sschorr@jaguarlandrover.com](mailto:sschorr@jaguarlandrover.com)

Office: +1-201-760-8561

Cell: +1-201-739-2964

**Nathan Hoyt**

Product Communications Manager  
Jaguar Land Rover North America, LLC

[nhoyt@jaguarlandrover.com](mailto:nhoyt@jaguarlandrover.com)

Office: +1-201-818-8316

Cell: +1-551-427-3199

**Q2 Why is Jaguar Land Rover North America recalling certain Jaguar vehicles?**

**A** Jaguar Land Rover was informed that Takata submitted a Defect Information Report (DIR) to the National Highway Traffic Safety Administration (NHTSA) reporting a potential safety defect for airbag inflators without a chemical drying agent (i.e., non-desiccated inflators) which are used in the front passenger airbag modules installed into 2009 and 2012 Model Year (MY) Jaguar XF vehicles.

Takata's investigation of affected inflators to date indicates that exposure to certain environmental conditions (several years of exposure to persistent conditions of high absolute humidity) could lead to over-aggressive combustion in the event of a front passenger airbag deployment.

In the event of an inflator rupture, metal fragments could tear through the airbag material, which may result in injury to vehicle occupants.

**Q3 Can you tell me more about what is wrong with the vehicles?**

**A** Takata has advised us that Takata airbag inflators similar in design to those used on certain Jaguar XF vehicles may, in a crash where the front passenger airbag system deploys, the airbag inflator housing may rupture.

In the event of an inflator rupture, metal fragments could pass through the airbag material, which may result in serious injury or death to vehicle occupants.

**Q4 How would the customer become aware of potentially having this concern?**

**A** There are no external signs of degradation of the airbag inflator. There has been extensive press coverage of this issue; certain Jaguar Land Rover vehicles are now included in the widely-covered Takata airbag inflator recalls which cover some 70 million Takata airbag inflators in the USA and approximately 100 million Takata airbag inflators worldwide used widely across the automotive industry.

Additionally, Jaguar Land Rover notified all affected owners in March 2017 advising their vehicle was included in this recall and that parts to remedy the defect were not yet available.

**Q5 Does this concern affect vehicle safety?**

**A** Yes. These types of airbag inflators with ammonium nitrate without desiccant propellant pose a safety risk.

**Q6 Has Jaguar Land Rover Limited received many complaints?**

**A** To date, we have not received any related complaints or are aware of any instances of ruptured inflators in Jaguar Land Rover vehicles.

**Q7 Have there been any accidents or injuries?**

**A** To date, we have not received any related complaints or are aware of any instances of ruptured inflators in Jaguar Land Rover vehicles.

**Q8 How was the condition discovered?**

**A** The condition was reported to Jaguar Land Rover by Takata. This is an industry-wide issue which has received significant press coverage. For more information on the Takata industry-wide situation, please visit <http://www.safercar.gov/rs/takata/index.html>.

**Q9 How long has Jaguar Land Rover known about this problem?**

**A** This issue was first known in May 2016, when Takata submitted a Defect Information Report (DIR) to the NHTSA regarding the potential defect in certain Jaguar Land Rover vehicles.

**Q10 Is the defect leading you to any concerns regarding the reliability of a system, which is supposed to be designed and engineered for the passengers' safety? What type of measures are you planning to take?**

**A** Jaguar Land Rover has no concerns with the overall reliability of vehicles. Jaguar Land Rover carefully monitors data to make sure that any matters relating to safety and compliance are rigorously investigated.

**Q11 What has Jaguar Land Rover done in production?**

**A** The vehicles affected by this issue are no longer in production. Parts for the recall remedy contain a different type of inflator propellant.

**Q12 What will authorized Jaguar retailers do to the vehicles?**

**A** Authorized Jaguar retailers will replace the front passenger airbag module on the affected vehicles.

**Q13 What about the driver airbag?**

**A** The driver airbag does not incorporate a Takata non-desiccated ammonium nitrate inflator and is not subject to recall.

**Q14 Which vehicles are affected by this recall (J070)?**

**A** Certain 2012MY Jaguar XF vehicles are included in this recall originally sold, or ever registered, in Alabama, California, Florida, Georgia, Hawaii, Louisiana, Mississippi, South Carolina, Texas, Puerto Rico, American Samoa, Guam, The Northern Mariana Islands (Saipan), the U.S. Virgin Islands. This geographical designation is also known as 'Zone A', as defined in the respective Coordinated Remedy Orders issued by NHTSA.

Additionally, certain 2009MY XF vehicles, originally sold, or ever registered, in Arizona, Arkansas, Delaware, District of Columbia, Illinois, Indiana, Kansas, Kentucky, Maryland, Missouri, Nebraska, Nevada, New Jersey, New Mexico, North Carolina, Ohio, Oklahoma, Pennsylvania, Tennessee, Virginia and West Virginia. This geographical designation is also known as 'Zone B', as defined in the respective Coordinated Remedy Orders issued by NHTSA.

2009 and 2012MY Jaguar XF vehicles not originally sold or ever registered in these states or Federalized Territories are not subject to this recall.

**Q15 Are other Jaguar Land Rover models affected by these actions?**

**A** Yes. This issue also affects certain Jaguar Land Rover vehicles.

A separate Safety Recall, J069, includes certain 2009-2011MY Jaguar XF vehicles originally sold, or ever registered, in 'Zone A', as defined in the respective Coordinated Remedy Orders issued by NHTSA. See Appendix 'A' for details.

This issue also affects certain Land Rover Range Rover vehicles. A separate Safety Recall, P081, includes certain 2007-2011 model year Range Rover vehicles originally sold, or ever registered, in 'Zone A', as defined in the respective Coordinated Remedy Orders issued by NHTSA. See Appendix 'A' for details.

Additionally, Safety Recall P081 also includes certain 2007-2008MY Range Rover vehicles originally sold, or ever registered, in 'Zone B', as defined in the respective Coordinated Remedy Orders issued by NHTSA. See Appendix 'A' for details.

A separate Safety Recall, P082, includes certain 2012MY Rover Range Rover vehicles originally sold, or ever registered, in 'Zone A', as defined in the respective Coordinated Remedy Orders issued by NHTSA. See Appendix 'A' for details.

Additionally, Safety Recall P082 also includes certain 2009MY Range Rover vehicles originally sold, or ever registered, in 'Zone B', as defined in the respective Coordinated Remedy Orders issued by NHTSA. See Appendix 'A' for details.

Additionally, Safety Recall P082 also includes certain 2007-2008MY Range Rover vehicles originally sold, or ever registered, in 'Zone C', as defined in the respective Coordinated Remedy Orders issued by NHTSA. See Appendix 'A' for details.

Additionally, Safety Recall P082 also includes certain 2007-2008MY Range Rover vehicles originally sold, or ever registered, in Canada.

**Q16 Are parts available to rework vehicles?**

**A** Yes. Parts are available to perform this recall to support and reassure customers who raise concerns and may not be willing to adhere to the interim vehicle operating advice provided by Jaguar Land Rover.

**Q17 How much will the recall cost Jaguar Land Rover?**

**A** Cost was not a factor in deciding to recall these vehicles.

**Q18 How do I know if my Jaguar vehicle is affected?**

**A** When adequate inventory of replacement parts is available, a second owner notification letter will be mailed to the first priority group of owners of registered vehicles in Zones 'A' and 'B' as defined in the Coordinated Remedy Orders issued by NHTSA. Owners of the remaining affected Zones 'A' and 'B' vehicles will be subject to later mailing notifications. In addition, a number of additional contact strategies are, uniquely for this Takata airbag recall, going to be adopted, including: the use of social media; customer email contact; additional press awareness for Jaguar Land Rover; and heightened repairer engagement. Should a customer wish to know if their vehicle is affected by this recall, they may go to <http://www.jaguarusa.com/owners/vin-recall.html> to inquire. Alternatively, they may access the same information through NHTSA at <https://www.nhtsa.gov/recalls>. Vehicle owners are also welcome to contact an authorized Jaguar retailer to inquire as to the recall status of their vehicle.

Vehicle owners are also welcome to contact an authorized Jaguar retailer to inquire as to the recall status of their vehicle.

**Q19 How long does it take for the vehicle to be inspected and repaired?**

**A** The work will be carried out as quickly and efficiently as possible in order to minimize inconvenience to customers and is expected to take approximately two (2) hours to complete, although your retailer may need your vehicle for a longer time. Your retailer can provide you with a better estimate of the overall time for the service visit.

**Q20 Can I continue to drive my vehicle safely until it has been repaired?**

**A** Yes. However, when customers receive a letter notifying them to have this free Safety Recall repair performed by an authorized Jaguar retailer, they should make contact immediately to schedule an appointment. If they are not the only driver of this vehicle, customers are requested to advise all other drivers of this important information.

**Q21 Why is the driver airbag not affected?**

**A** The driver airbag does not contain a Takata inflator, so it is not affected by this recall.

**Q22 Why are other models not included?**

**A** Aside from certain Land Rover Range Rover models, other models are not included because this recall pertains specifically to vehicles equipped with the Takata non-desiccated ammonium nitrate airbag inflators.

**Q23 Does the Takata airbag recall affect Canadian vehicles?**

**A** Yes, this Takata airbag recall does affect certain Jaguar Land Rover vehicles in Canada. See Q15.

**Q24 Are you making loan vehicles available to owners of affected vehicles?**

**A** Each retailer will seek to support owners of affected vehicles as circumstances require in line with normal retailer operating procedures.

**Q25 If a customer requests it, can we disable their airbag?**

**A** No. For those vehicles included in this recall, a remedy is available. As a leader in the field of automotive safety, we believe that the driver and passengers are always safer with the protection of the airbag when a collision event warrants a deployment.

The airbag is designed to supplement the seatbelt and other restraint components. For these reasons, we will not allow retailers to disable airbags.

Until the remedy is completed, if customers are so concerned, the front passenger airbag will NOT operate where the front passenger seat is unoccupied. As such, customers who are uncomfortable have the option not to sit someone in the front passenger seat until the repair is performed.

**Q26 What about the other model year XF vehicles which are affected?**

**A** For this recall (J070), there are no other model year Jaguar XF vehicles affected.