

## MULTI-MODEL - LIFTGATE STAY DAMPER SAFETY RECALL 9916H REPAIR PROCEDURE

---

### A. VEHICLE INSPECTION PROCEDURE

1. Verify that the vehicle is within the following range:

Model / Model Year	VIN Range		Build Date Range
2016 CX-3	JM1 DK****	G0 100037 - 131129	From Mar. 10, 2015 through Dec. 26, 2015
2013 CX-5	JM3 KE****	D0 100063 - 170454	From Dec. 15, 2011 through Dec. 26, 2015
2014 CX-5		E0 300040 – 430753	
2015 CX-5		F0 430754 – 554564	
2016 CX-5		G0 600015 – 760020	
2010 Mazda3 (5-Door) and Mazdaspeed3	JM1 BL***	A1 100652 – 381090	From Nov. 18, 2008 through Jun. 11, 2013
2011 Mazda3 (5-Door) and Mazdaspeed3		B1 354782 – 903167	
2012 Mazda3 (5-Door) and Mazdaspeed3		C1 500035 – 701155	
2013 Mazda3 (5-Door) and Mazdaspeed3		D1 704374 – 844419	
2012 Mazda5	JM1 CW****	C0 100018 – 144686	From Oct. 26, 2010 through Dec. 26, 2015
2013 Mazda5		D0 144687 – 162756	
2014 Mazda5		E0 162757 – 178585	
2015 Mazda5		F0 178586 – 191325	
2016 Mazda5		G0 191326 – 191864	

- If the vehicle is within one of the above ranges, proceed to Step 2.
- If the vehicle is not within one of the above ranges, return vehicle to the customer or inventory.

- Perform a Warranty Vehicle Inquiry using your eMDCS System and inspect vehicle for Campaign Labels **Recall 9916H** attached to the vehicle's hood or bulkhead. Refer to eMDCS System - Warranty Vehicle Inquiry Results table below.

**NOTE:** Be sure to verify Recall number as the vehicle may have multiple Recall labels.

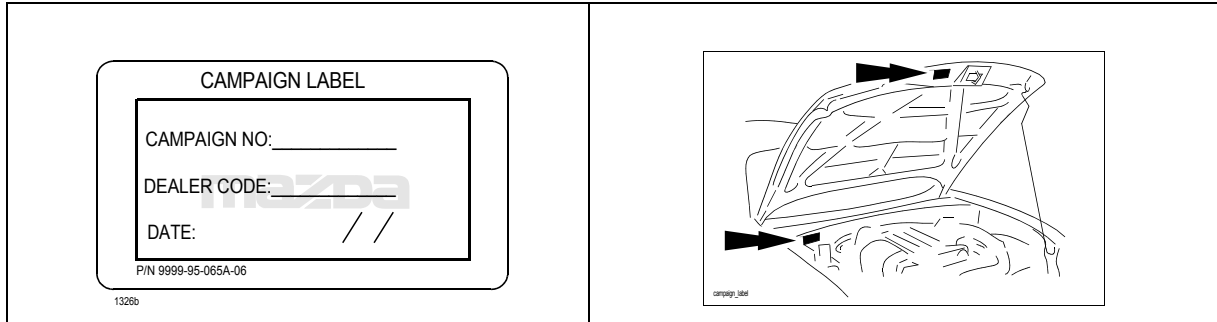

**eMDCS System - Warranty Vehicle Inquiry Results:**

If eMDCS displays:	Campaign Label is:	Action to perform:
RECALL 9916H OPEN	Present	Contact the Warranty Hotline at (877) 727-6626 option 3 to update vehicle history.
	Not present	Proceed to "B. INSPECTION PROCEDURE".
RECALL 9916H CLOSED	Present	Return vehicle to inventory or customer.
	Not present	Complete a label and apply to vehicle's hood or bulkhead.
RECALL 9916H is not displayed	Does not apply	Recall does not apply to this vehicle. Return vehicle to inventory or customer.

## B. INSPECTION PROCEDURE

**WARNING:** When a lift gate stay damper has already reached a certain level of corrosion, it is possible that it could rupture in the area of the caulking (see below). People can be injured when the lift gate is opened and the rear damper(s) rupture.

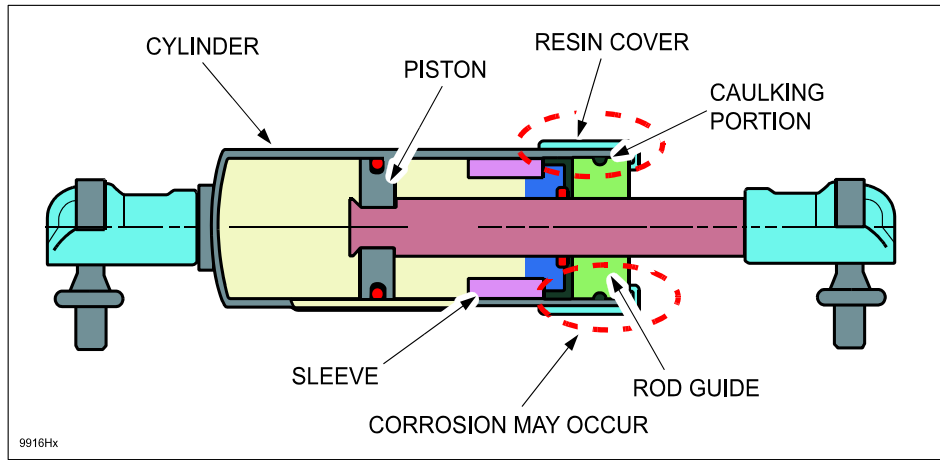

**NOTE:** In the procedure below, the lift gate stay damper is to be described as just “stay damper”.

**WARNING:** Be aware that when removing corroded stay damper(s), the gas sealed inside the dampers could escape unexpectedly. As a result, you and/or other people could be injured. Be sure to review the Warnings, Cautions and Notes below before performing any repairs.

### **WARNING:**

- Wear protective glasses when performing repairs.
- Wear protective gloves when performing repairs.
- Work with the help of one (1) other person to help support the lift gate.
- If working alone, use wooden support rods/dowels/equivalent to help support the lift gate and prevent potential stress on the hinges or injury from the open liftgate falling on you.
- If using wooden support rods/dowels/equivalent, cover the ends to protect the paint on the lift-gate and vehicle body.
- Support person should also avoid standing in front of the stay damper(s).
- Pay attention to the open the lift gate. DO NOT let the open lift gate fall on you or the other person.

**CAUTION:** Mount fender covers (as shown below) onto the vehicle to avoid scratching the painted surface of the body, bumper cover and lift gate.

**NOTE:**

- Avoid working directly in front of the stay damper(s). Work from the center of the vehicle in the work area (as shown below).
- Work in an area where there are no other vehicles parked behind the subject vehicle.
- **Do not work on both stay dampers at the same time.**
- **Replace one stay damper at a time.**

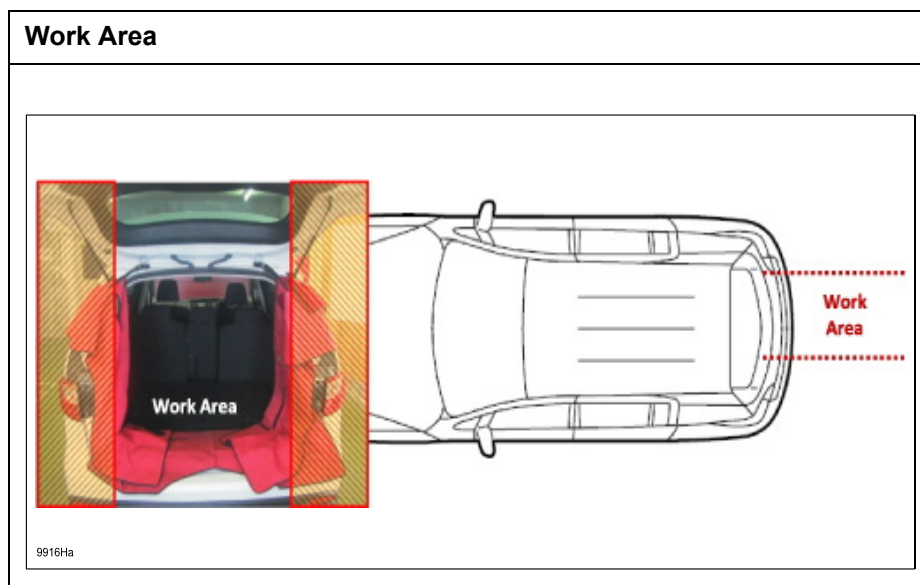

## Tool Kit



1a	Gauge Tool - Large Inner Diameter (Mazda5, and CX-5)	3	Bands
1b	Gauge Tool - Small Inner Diameter (Mazda3 and CX-3)	4	Tie-Down Strap
2	Support Cylinder	5	Degassing Tool

## Work Flow

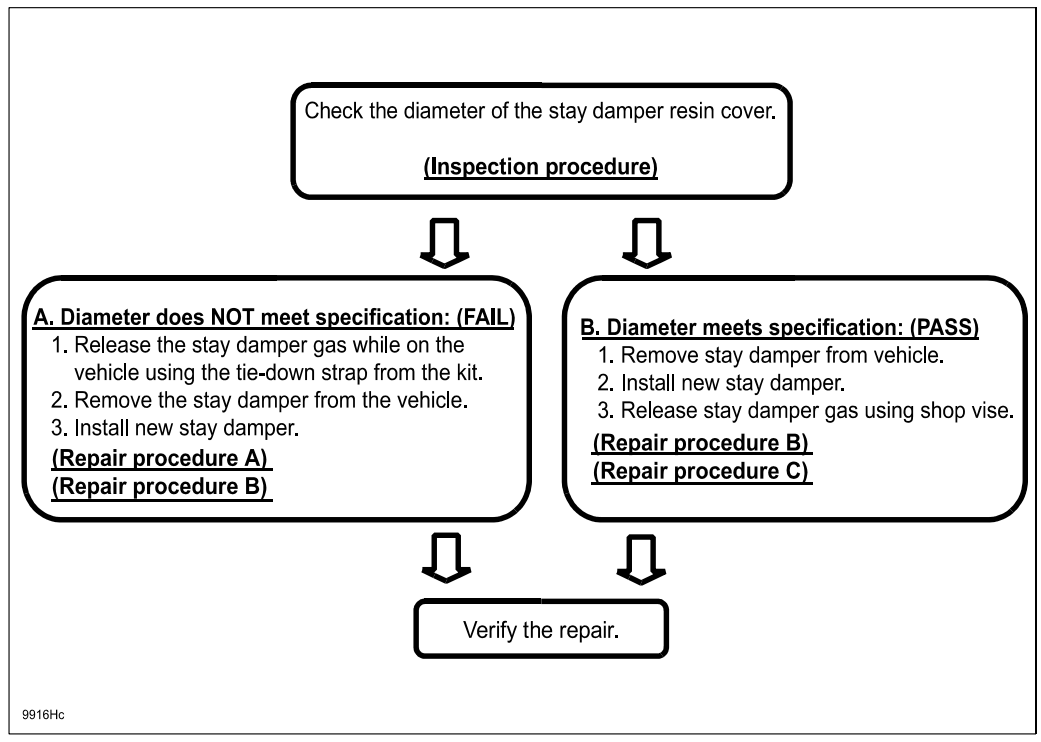

- From the rod side of the stay damper, use the gauge tool (A) to pass over the resin cover (B) of the stay damper (as shown below).

**NOTE:** In order to confirm a small bulge in the resin cover, (that may not be confirmed by visual inspection), always be sure to use the gauge tool.

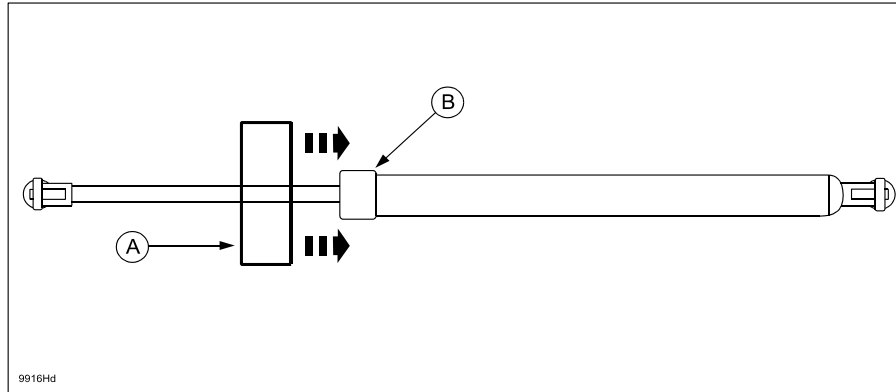

- Make one (1) rotation with the gauge tool (A) over the resin cover (B), as shown below.

**NOTE:** The formation of rust/corrosion inside the resin cover causes it to expand/increase in diameter. If there is resistance (even a small amount), DO NOT force the gauge tool over the resin cover.

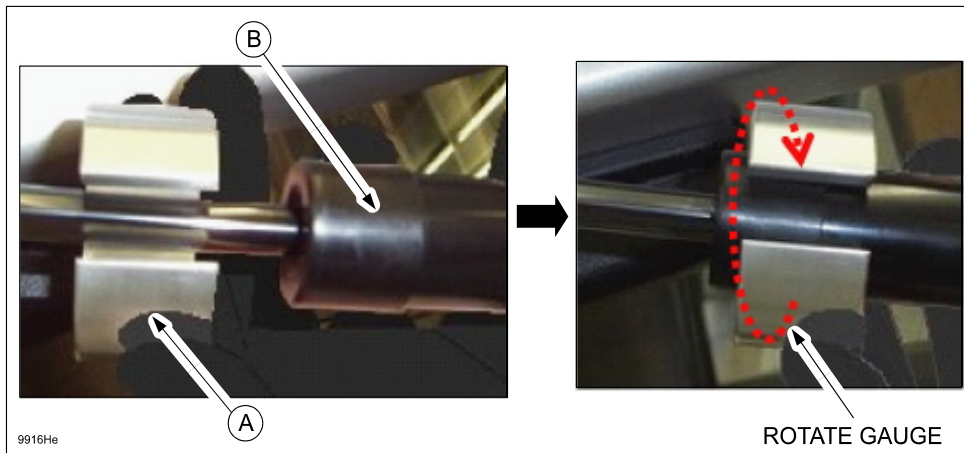

**Result of resin cover inspection with gauge tool:**

Result	Next Step	Repair Procedure
<b>FAIL:</b> The gauge tool is caught on the resin cover. It does not pass smoothly or cannot be rotated over the resin cover.	1. Release the stay damper gas while on the vehicle using the tie-down strap from the kit.	<b>A</b>
	2. Remove the stay damper from the vehicle.	<b>B</b>
	3. Install new stay damper.	<b>B</b>
<b>PASS:</b> The gauge tool passes smoothly over the resin cover and the rotation does not leave scratches on the resin cover.	1. Remove stay damper from vehicle.	<b>B</b>
	2. Install new stay damper.	<b>B</b>
	3. Release stay damper gas using shop vise.	<b>C</b>

## REPAIR PROCEDURE A:

### Releasing Stay Damper Gas While On The Vehicle:

1. Install fender covers to protect the lift gate area from damage.



2. Adjust the length of the tie-down according to the subject vehicle.

#### NOTE:

- CX-3 - 530 mm
- CX-5 - 450 mm
- Mazda3 HB - 560 mm
- Mazda5 - 510 mm (example shown below)

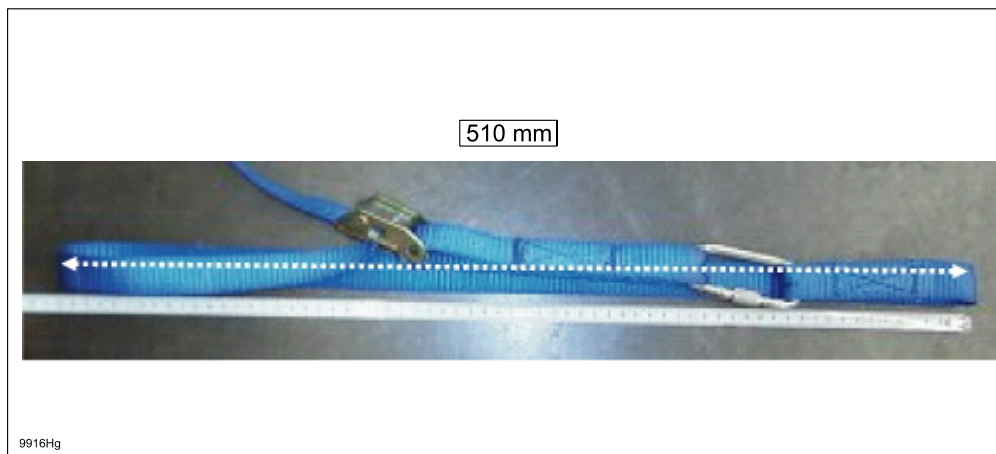

3. Attach the support cylinder (A) to the rod side of the stay damper with the cut-out side facing outward (as shown below).

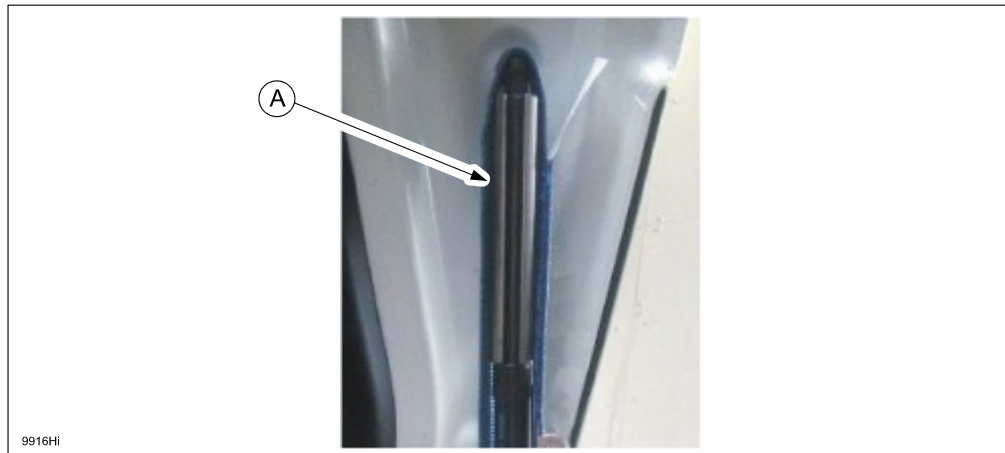

**NOTE:** Illustration above is shown with tie-down already installed.

**NOTE:** Align the end of the support cylinder (A) with the stay damper (as shown below).

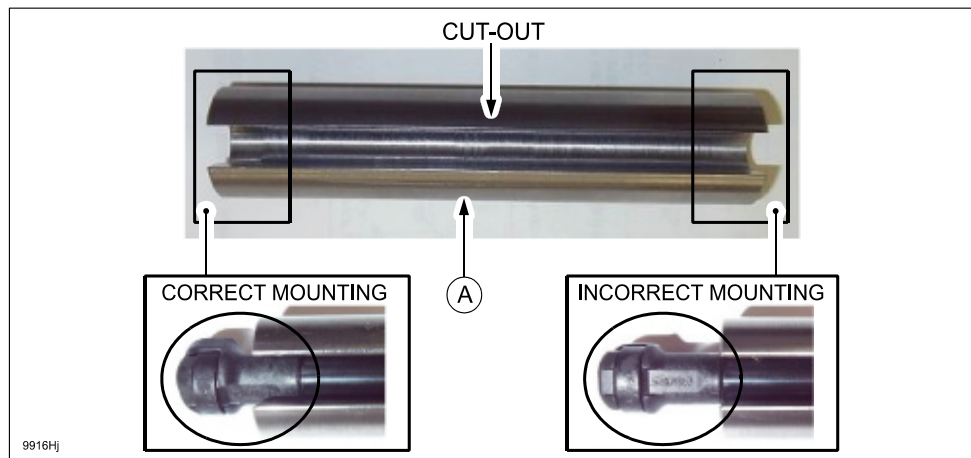



4. Install the tie-down around both ends of the stay damper (as shown below).

**CAUTION:** If the metal tie-down buckle (A) contacts the resin cover (B), the stay damper is likely to fall off of the vehicle.

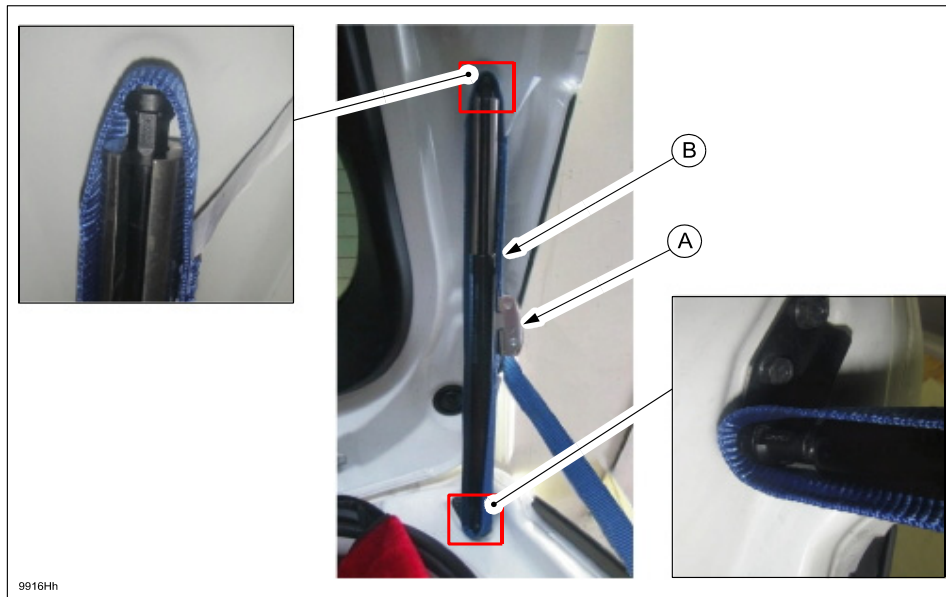

**NOTE:**

- CX-3 - 530 mm
- CX-5 - 450 mm
- Mazda3 HB - 560 mm
- Mazda5 - 510 mm

5. While the support person slowly lowers the lift gate, tighten the tie-down until the support cylinder (A) contacts the top of the stay damper resin cover (B).

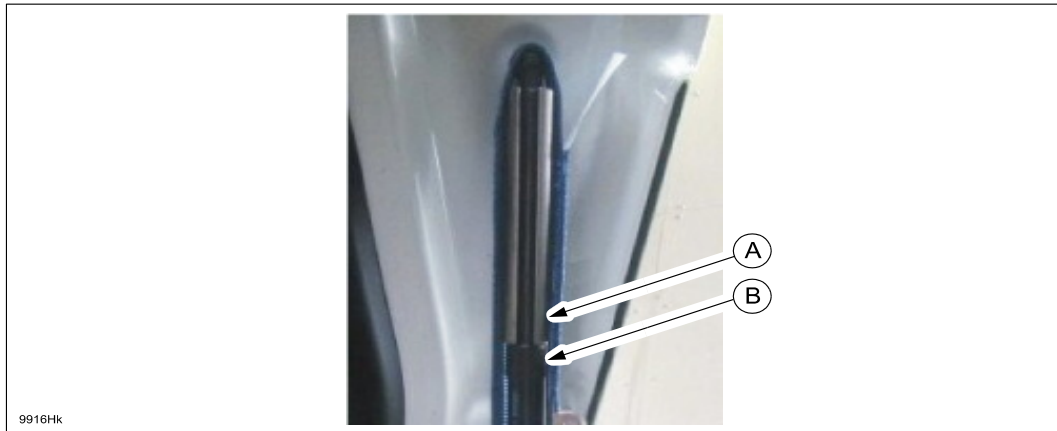

6. As the support person (or wooden support rods/dowels) holds the lift gate in place, install a band around the tie-down and supporting cylinder as shown below.



7. From inside the vehicle, mark the spot (A) 140 mm from the end of the body side of the stay damper.

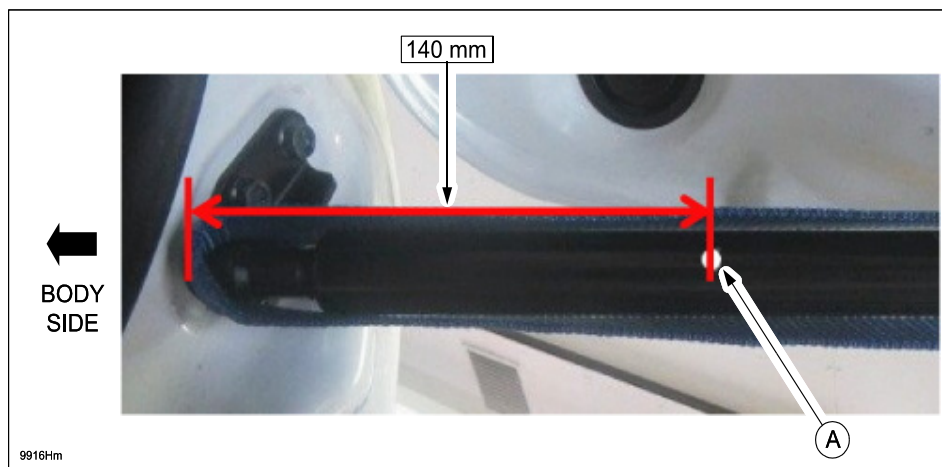

8. Install the degassing tool (A) around the stay damper, as shown below.

**CAUTION:**

- Wear protective glasses and gloves when degassing the stay damper.
- Do not loosen or remove the degassing tool when the gas begins to escape.
- Cover the puncture site with a shop rag.

**NOTE:** Tighten the pointed tip of the degassing tool by hand, until it contacts the spot previously marked at 140 mm.

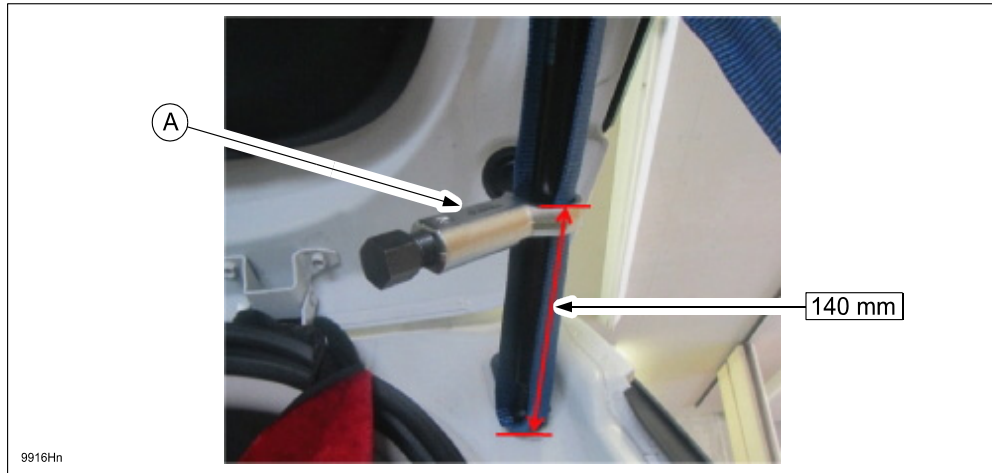

9. Tighten the end of the degassing tool (A) with a wrench, until gas is heard escaping the stay damper.

**NOTE:** Hold the degassing tool in one hand with a shop rag (B).

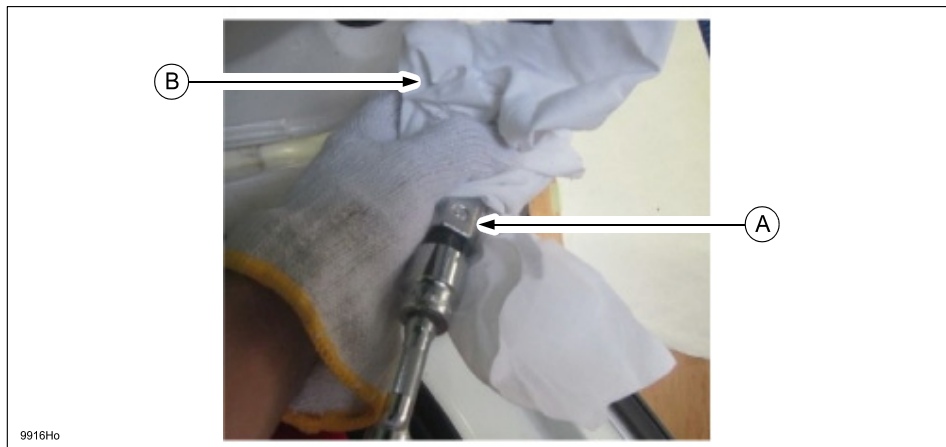

10. When there is no longer a sound of gas escaping, the degassing is complete.

11. Remove the band, tie-down and support cylinder from the stay damper.

12. Repeat Steps 1 - 11 on opposite side stay damper.

## REPAIR PROCEDURE B:

### Stay Damper Removal / Installation:

**NOTE:** The following repair procedures were performed using the right side stay damper, like the one shown below.

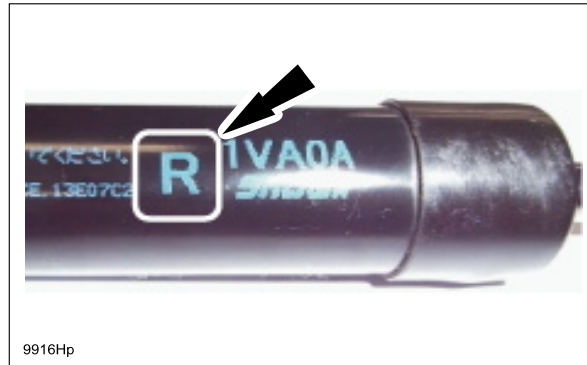

1. Check the appearance of the new stay damper before installing it on the vehicle.
  - Verify there are no scratches on the new stay damper rod.
  - Verify there is no oil leaking from new stay damper.

**NOTE:** If the stay damper has scratches and/or oil leaks, do not use it.

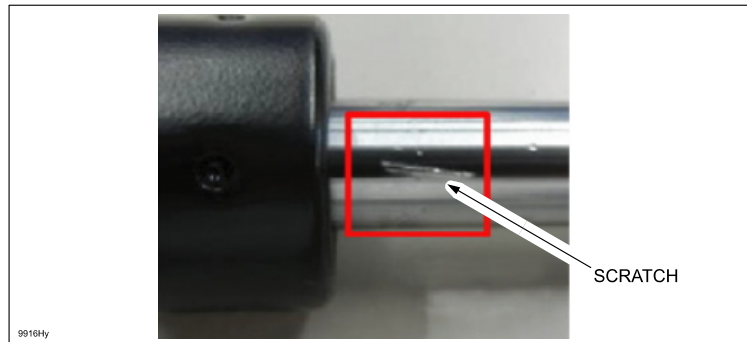

2. Be careful not to scratch the rod during the stay damper replacement and do not use any tools on the new stay damper shaft (i.e. vise-grips, etc.) during installation.
3. After installing the new stay dampers, open and close the lift gate several times to check there is no oil leaking from the stay damper rods.

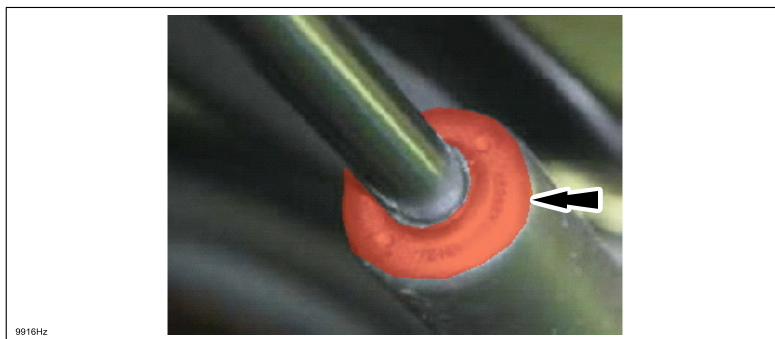

**>Mazda5, Mazdaspeed3 and Mazda3 (5-Door Hatchback):**

1. Using a small screwdriver, remove the stay damper bands at the lift gate side (A) and the vehicle side (B) as shown below.

**NOTE:** Work with the help of at least one (1) other person to help support the lift gate.

**CAUTION:**

- Be careful not to damage the painted surface of the vehicle.
- If the painted surface is damaged, it must be repaired according to normal body shop practices.

**NOTE:**

- There is a possibility that the lift gate hinge was deformed when using the support cylinder to support the lift gate.
- DO NOT use the support cylinder to hold the lift gate up by the opposite side stay damper.
- Be sure that the support person holds the lift gate up by hand or with wooden support rods/dowels.

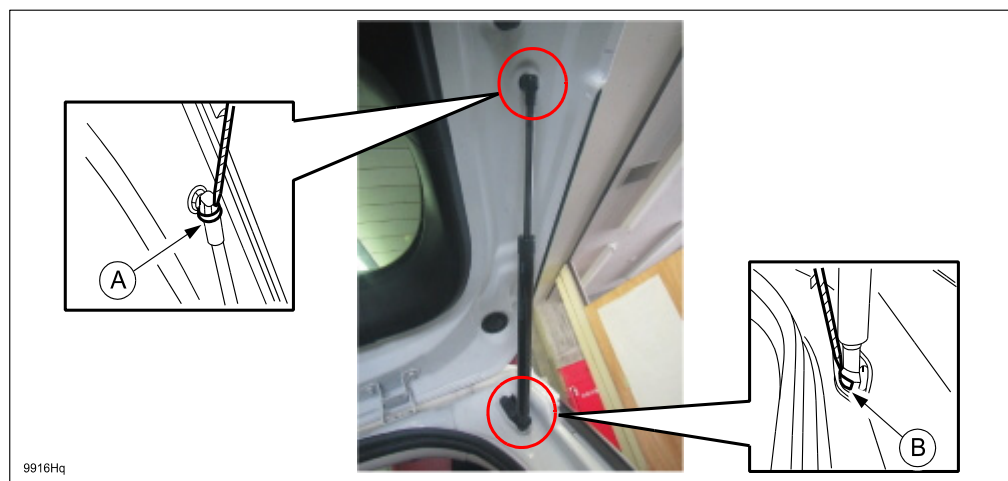

2. Clean the stud-ball on the lift gate side and the vehicle side with a cloth after stay damper removal.
3. Install the modified stay damper to the stud-ball housing onto the **vehicle side**.
4. Install the modified stay damper to the stud-ball housing onto the **lift gate side**.
5. Rotate the stay damper to make sure that the metal clip is not floating from the stud-ball housing.

**NOTE:** Verify there are no abnormal lift gate noises and the lift gate opens and closes properly.

**>CX-3 and CX-5:**

(For CX-5 Only): Select the proper part number by referring to following information.

How to identify the CX-5 stay dampers:

Confirm the label on the stay damper (as shown below).

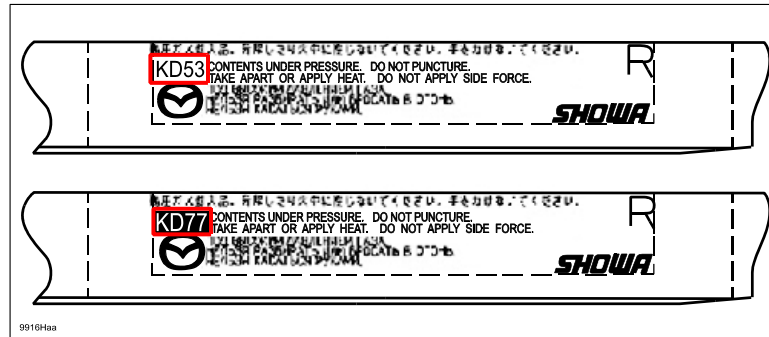

- If "KD53" is printed on the label, replace the part with KDY3-76-61X.
- If "KD77" is printed on the label, replace the part with KDY7-76-61XA.

**NOTE:**

- Part number KDY8-76-61XA exists in some areas.
- Part numbers KDY8-76-61XA and KDY7-76-61XA are compatible.

**NOTE:**

- Do not use part number KDY3-76-61X for vehicles with "KD77".
- Do not use part numbers KDY7-76-61XA or KDY8-76-61XA for vehicles with "KD53".
- These combinations are NOT compatible.

1. Using a small screwdriver, remove the stay damper band at the lift gate side (A) as shown below.

**NOTE:** Work with the help of at least one (1) other person to help support the lift gate.

**CAUTION:** Be careful not to damage the painted surface of the vehicle.

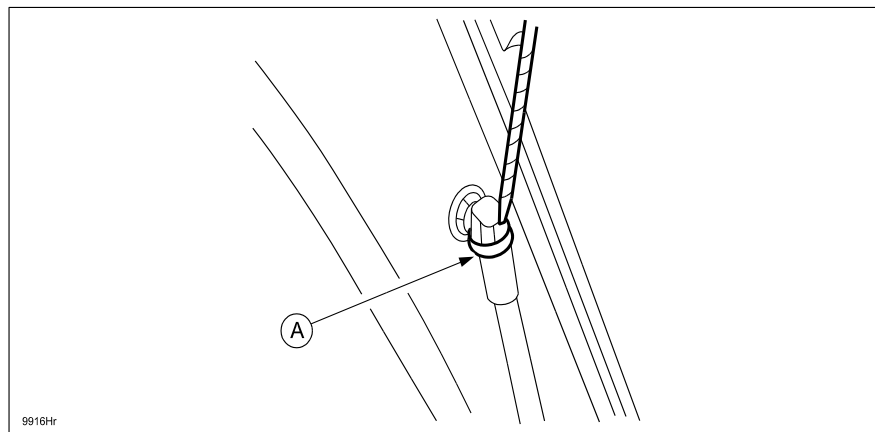

**NOTE:**

- There is a possibility that the lift gate hinge was deformed when using the support cylinder to support the lift gate.
- DO NOT use the support cylinder to hold the lift gate up by the opposite side stay damper.
- Be sure that the support person holds the lift gate up by hand or with wooden support rods / dowels.

2. Remove the stay damper bracket bolts from the vehicle side (as shown below) to remove the stay damper.

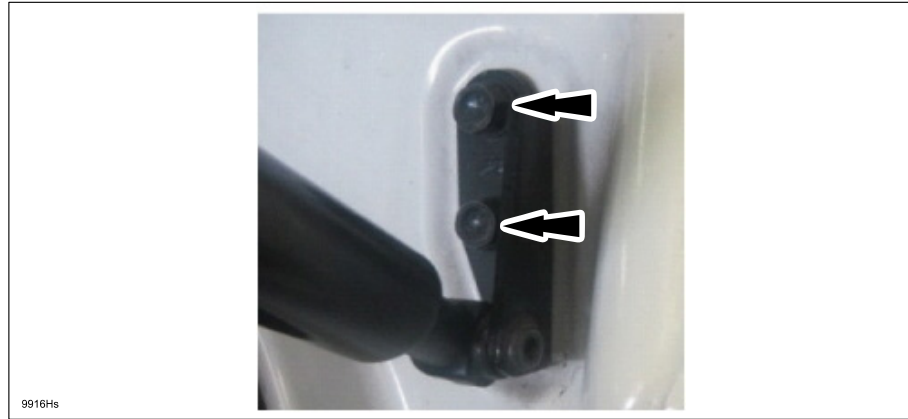

**CAUTION:**

- Be careful not to damage the painted surface of the vehicle.
  - If the painted surface is damaged, it must be repaired according to normal body shop practices.
3. Clean the mounting surface of the stay damper bracket, using special care to prevent damage to the painted surface under the bracket.
  4. Clean the stud-ball on the lift gate side with a cloth, after stay damper removal.
  5. Install the modified stay damper to the stud-ball housing onto the **lift gate side**.
  6. Rotate the stay damper to make sure that the metal clip is not floating from the stud-ball housing.
  7. Install the stay damper bracket bolts onto the **vehicle side**.
  8. Tighten the stay damper bracket bolts to the proper torque specification.

**Tightening Torque: 80 - 133 in. lbs. {92 - 153 kgm-cm, 9 - 12 Nm}**

**NOTE:** Verify there are no abnormal lift gate noises and the lift gate opens and closes properly.

9. Apply a rust preventive coating around the mounting bracket and bolt areas (as shown below).

**NOTE:** Mask the area to prevent over-spray from coating the surface. Wipe off excess coating as necessary using a clean towel.

**Rust Preventative Coating Recommendation: ValuGard Rust Preventative – Part # VG-101-A.**



**NOTE:** One (1) can of rust preventive will be dropped ship to each Mazda dealer prior to the campaign.

Additional Rust Preventative product can be ordered through Automotive International at:

Automotive International  
8855 Blue Ash Rd.  
Cincinnati, OH. 45242

Phone (800) 543-7156 or [orders@autointl.com](mailto:orders@autointl.com)  
Opened M-F (8:00 to 5:00 EST)  
Visa, Master Card and American Express are accepted



## REPAIR PROCEDURE C:

### Stay Damper Disposal:

**WARNING:** The stay damper contains colorless, odorless, non-toxic gas. When cutting the stay damper, wear protective eye wear to prevent the gas or oil from getting into your eyes. Otherwise, the force of the gas and oil spraying out could lead to injury.

1. Put on gloves and protective eye wear.
2. Secure the stay damper horizontally in a vice.
3. Using a metal saw, drain the gas and oil from the stay damper by cutting to a depth of 2 - 3 mm at the position shown below.

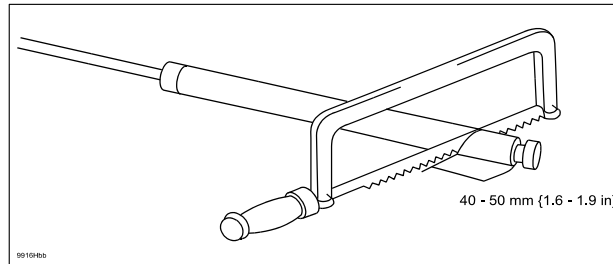

**WARNING:** Be careful, the cut end of the stay damper will be sharp and can cut your hands and fingers.

4. Verify the gas and oil is completely drained (into a suitable container) by pulling and pushing the piston rod several times with the cut position facing downward.

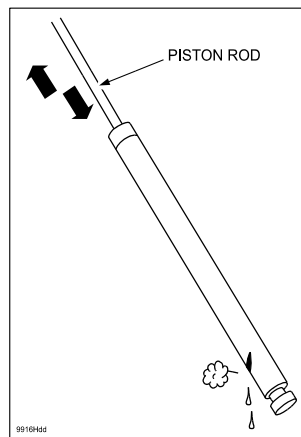

5. Cut off the bottom of the stay damper.

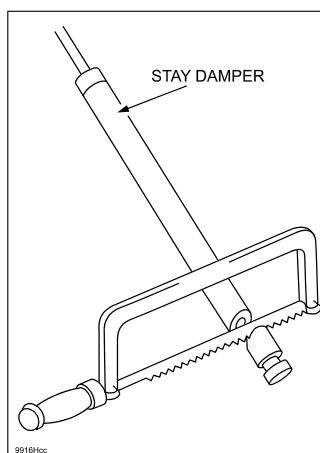

6. Dispose of the stay damper.

## D. CAMPAIGN LABEL INSTALLATION

1. Fill out a blue "Campaign Label" (9999-95-065A-06) with Campaign No: "9916H", your dealer code, today's date.

CAMPAIGN LABEL	
CAMPAIGN NO:	_____
DEALER CODE:	_____
DATE:	/  /

P/N 9999-95-065A-06

1326b

2. Affix it to the hood or bulkhead as shown:

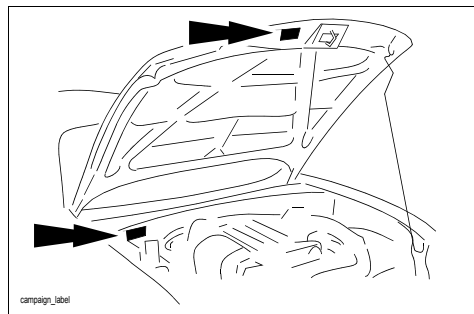

3. Return the vehicle to customer.