



Recall Service Bulletin



DATE: 9-30-16

APPLIES TO: This Recall service bulletin applies to model year 2009 through 2015 MetroStar and Gladiator model emergency response chassis cabs built by Spartan Motors USA, Inc. between January 05, 2010 and January 19, 2015.

NHTSA/TC Id: 15V-687

CONDITION: Power steering fluid may overheat and cause the steering to unexpectedly lose power assist during steering maneuvers.

CORRECTION:

LABOR ALLOCATION: 3.0 hrs.

CLASSIFICATION: E3

PARTS NEEDED:

<u>QTY</u>	<u>Part Number</u>	<u>Description</u>
1	S-2550-001B	Kit-Power Steering Cooler ISL Beam Axle

Kit # S-2550-001B Contains:

<u>QTY</u>	<u>Part Number</u>	<u>Description</u>
1	10W-10JA10JB075	Hose ASM 10-387TC/ST90/75" (2125-MM5)
1	10W-10JA10JB060	Hose ASM 10-387TC/ST90/60" (2125-MM5)
1	1941-KK1-001	Cooler-HYD Oil, ISL
1	RSB16-260-003	Instruction Document

<u>QTY</u>	<u>Part Number</u>	<u>Description</u>
1	S-2551-001B	Kit-Power Steering Cooler ISX Beam Axle

Kit # S-2551-001B Contains:

<u>QTY</u>	<u>Part Number</u>	<u>Description</u>
1	1942-KK1-001	Cooler-HYD Oil, ISX
1	1946-KK1-001	BRKT-Power Steering Cooler
2	06160075FH8Y	Bolt-3/8-16 X .75 LG FLG GR8 YEL

Service Bulletins are intended for use by Professional Technicians only. They are written to guide Professional Technicians in performing service to vehicles of specific nature in conjunction with industry standards. Professional Technicians are appropriately trained on industry standards and have the tools and equipment to perform procedures safely and properly.



Recall Service Bulletin



4	0616FLN8Y	Nut-3/8-16 FLG LK GR8 YEL
1	10W-10JA10JB087	Hose ASM 10-387TC/ST90/087" (2125-MM5)
1	10W-10JA10JM070	Hose ASM 10-387TC/ST90/070" (2125-MM5)
1	1404-FF3-001	Shield ASM-Recirc LH, 2010 ISX, GLAD
1	1947-KK1-001	BRKT- Power Steering Cooler
1	1947-KK1-002	BRKT- Power Steering Cooler
1	RSB16-260-003	Instruction Document

<u>QTY</u>	<u>Part Number</u>	<u>Description</u>
1	S-2555-001B	Kit-Power Steering Cooler ISL IFS

Kit # S-2555-001B Contains:

<u>QTY</u>	<u>Part Number</u>	<u>Description</u>
1	1941-KK1-001	Cooler-HYD Oil, ISL
1	10W-10JA10JB075	Hose ASM 10-387TC/ST90/75" (2125-MM5)
1	10W-10JA10JB067	Hose ASM 10-387TC/ST90/67" (2125-MM5)
1	RSB16-260-003	Instruction Document

<u>QTY</u>	<u>Part Number</u>	<u>Description</u>
1	S-2556-001B	Kit-Power Steering Cooler ISX IFS

Kit # S-2556-001B Contains:

<u>QTY</u>	<u>Part Number</u>	<u>Description</u>
1	1942-KK1-001	Cooler-HYD Oil, ISX
1	1946-KK1-001	BRKT-Power Steering Cooler
2	06160075FH8Y	Bolt-3/8-16 X .75 LG FLG GR8 YEL
4	0616FLN8Y	Nut-3/8-16 FLG LK GR8 YEL
1	10W-10JA10JB087	Hose ASM 10-387TC/ST90/087" (2125-MM5)
1	10W-10JA10JM081	Hose ASM 10-387TC/ST90/081" (2125-MM5)
1	1404-FF3-001	Shield ASM-Recirc LH, 2010 ISX, GLAD
1	1947-KK1-001	BRKT- Power Steering Cooler
1	1947-KK1-002	BRKT- Power Steering Cooler
1	RSB16-260-003	Instruction Document

Service Bulletins are intended for use by Professional Technicians only. They are written to guide Professional Technicians in performing service to vehicles of specific nature in conjunction with industry standards. Professional Technicians are appropriately trained on industry standards and have the tools and equipment to perform procedures safely and properly.



Recall Service Bulletin



GENERAL INSTRUCTIONS:

Thoroughly review entire service bulletin before starting work. If there are questions or concerns with steps defined in this service bulletin, contact Spartan Motors USA, Inc. Customer & Product Support Group.

All applicable industry safety standards must be followed when performing work identified in this procedure.

STEP-BY-STEP INSTRUCTIONS:

1. Remove front grill from truck cab to gain access to front of radiator package.
2. Drain hydraulic steering system using suitable container and dispose of steering fluid in accordance with local regulations.

Note: A drain pan or catch basin of some type should be used to capture fluid.

3. Remove power steering return line that goes from steering gear to bottom of hydraulic reservoir and discard.
4. Install provided cooler and hardware to front of radiator, apply blue Loctite (removable thread locker) to all bolts, and torque 3/8" fasteners to 27 ft.-lbs. Refer to FIG. 3-1 through 4-1 depending on engine type.

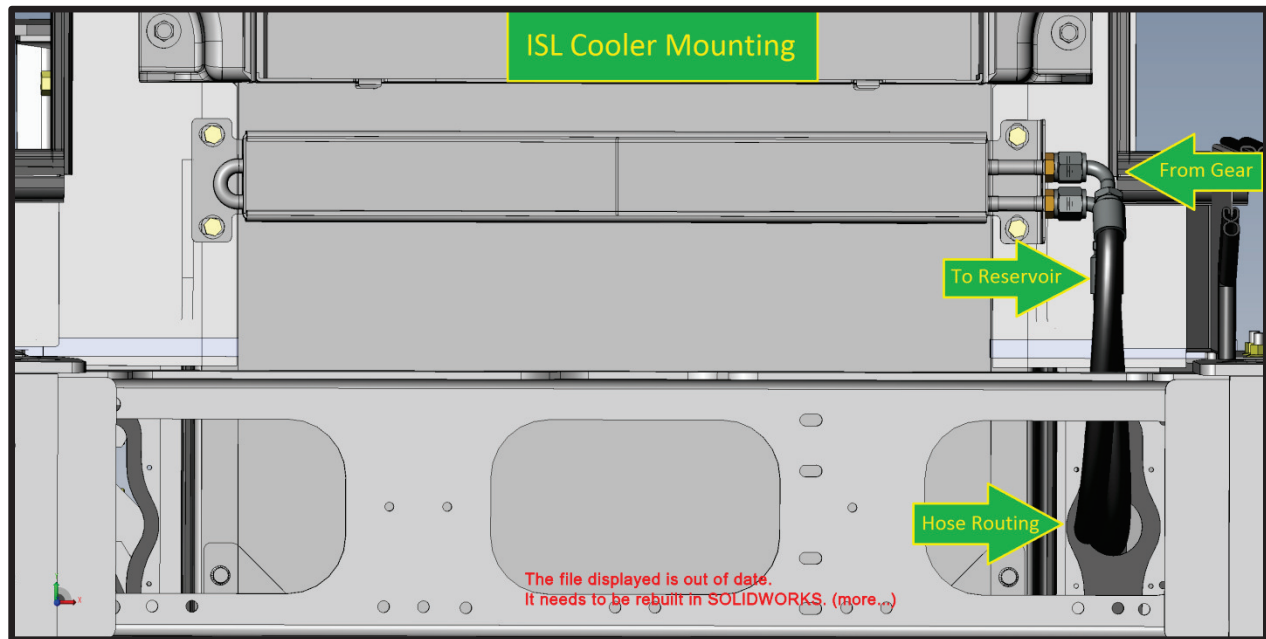

FIG. 3-1 - ISL Cooler Install

Service Bulletins are intended for use by Professional Technicians only. They are written to guide Professional Technicians in performing service to vehicles of specific nature in conjunction with industry standards. Professional Technicians are appropriately trained on industry standards and have the tools and equipment to perform procedures safely and properly.



Recall Service Bulletin

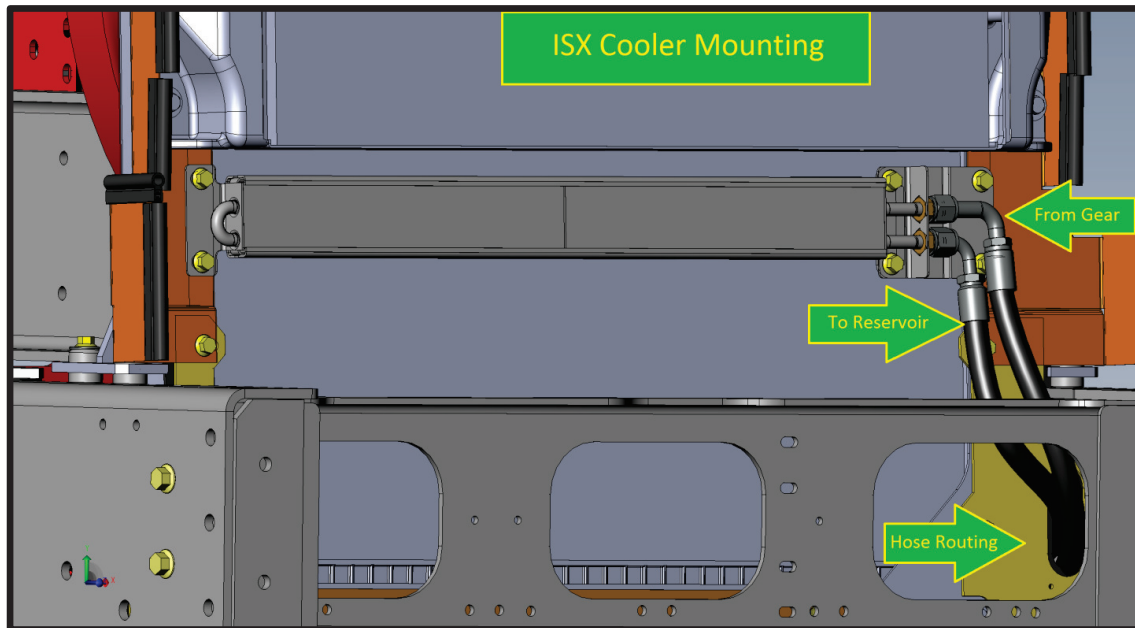

FIG. 4-1 - ISX Install

Service Bulletins are intended for use by Professional Technicians only. They are written to guide Professional Technicians in performing service to vehicles of specific nature in conjunction with industry standards. Professional Technicians are appropriately trained on industry standards and have the tools and equipment to perform procedures safely and properly.



Recall Service Bulletin



5. ISL – Cut a hole small enough to route two # 10 hoses through the lower driver side recirculation shield. ISX models only – remove and replace the driver side lower recirculation shield with one that is provided. Route the two # 10 hoses through the new recirculation shield. Refer to FIG. 5.1.

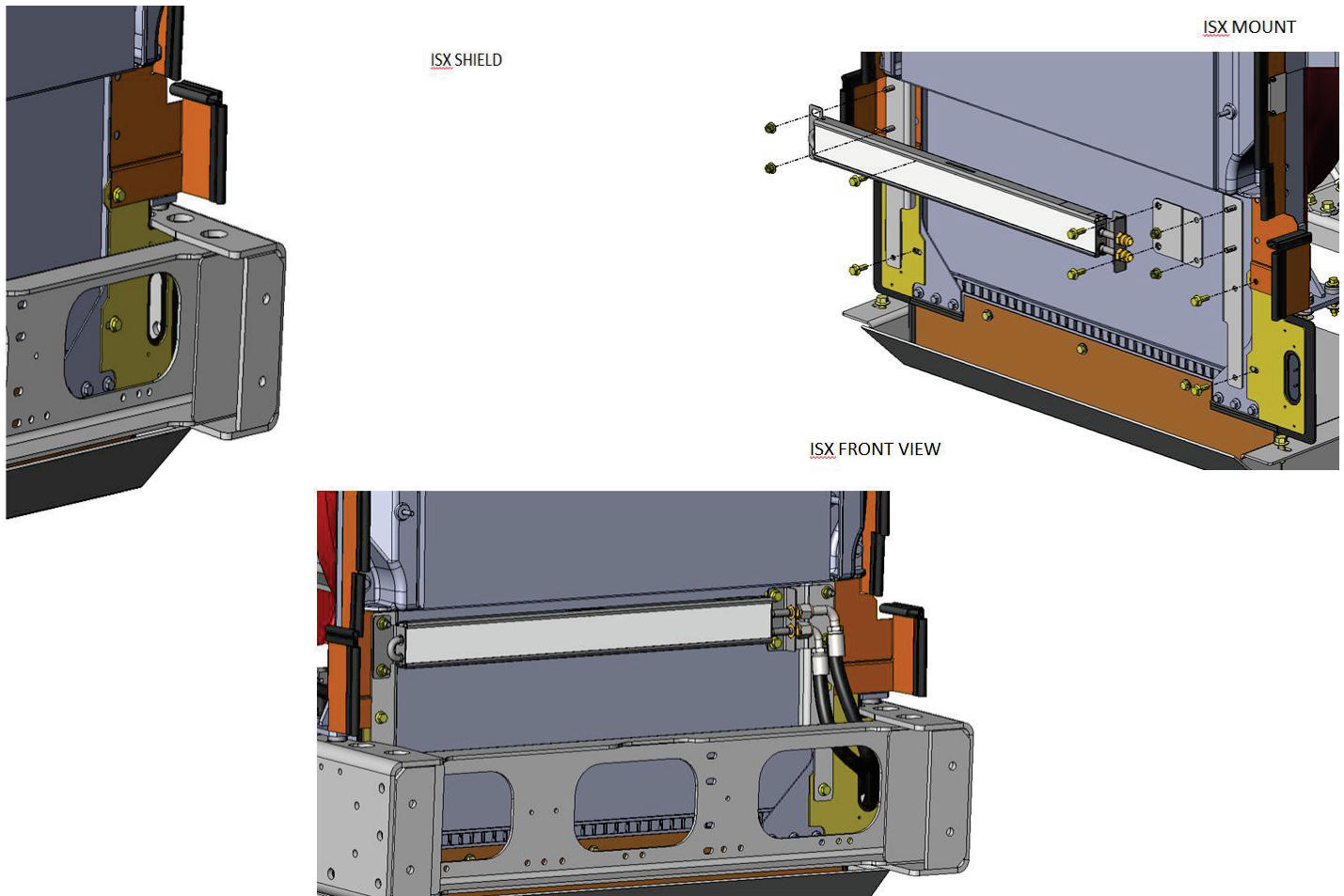

FIG.5-1

Service Bulletins are intended for use by Professional Technicians only. They are written to guide Professional Technicians in performing service to vehicles of specific nature in conjunction with industry standards. Professional Technicians are appropriately trained on industry standards and have the tools and equipment to perform procedures safely and properly.



Recall Service Bulletin



6. Route and install newly provided #10 return hose that goes from steering gear to top of power steering cooler. Torque fittings to 55 ft.-lbs. Refer to FIG. 7-1 and 8-1.
7. Route and install newly provided # 10 return hose that goes from power steering cooler to hydraulic reservoir. Torque fittings to 55 ft.-lbs. Refer to FIG. 7-1 and 8-1.

Ensure all hoses are secured adequately to prevent rubbing against any sharp or abrasive contact points. Ensure all hoses are routed without any kinks.

8. Fill hydraulic system using recommended fluid and TRW start up instructions. Refer to FIG. 9-1.
9. Reinstall front grill and run truck. Check for leaks and verify power steering is working as it should.

Service Bulletins are intended for use by Professional Technicians only. They are written to guide Professional Technicians in performing service to vehicles of specific nature in conjunction with industry standards. Professional Technicians are appropriately trained on industry standards and have the tools and equipment to perform procedures safely and properly.



Recall Service Bulletin

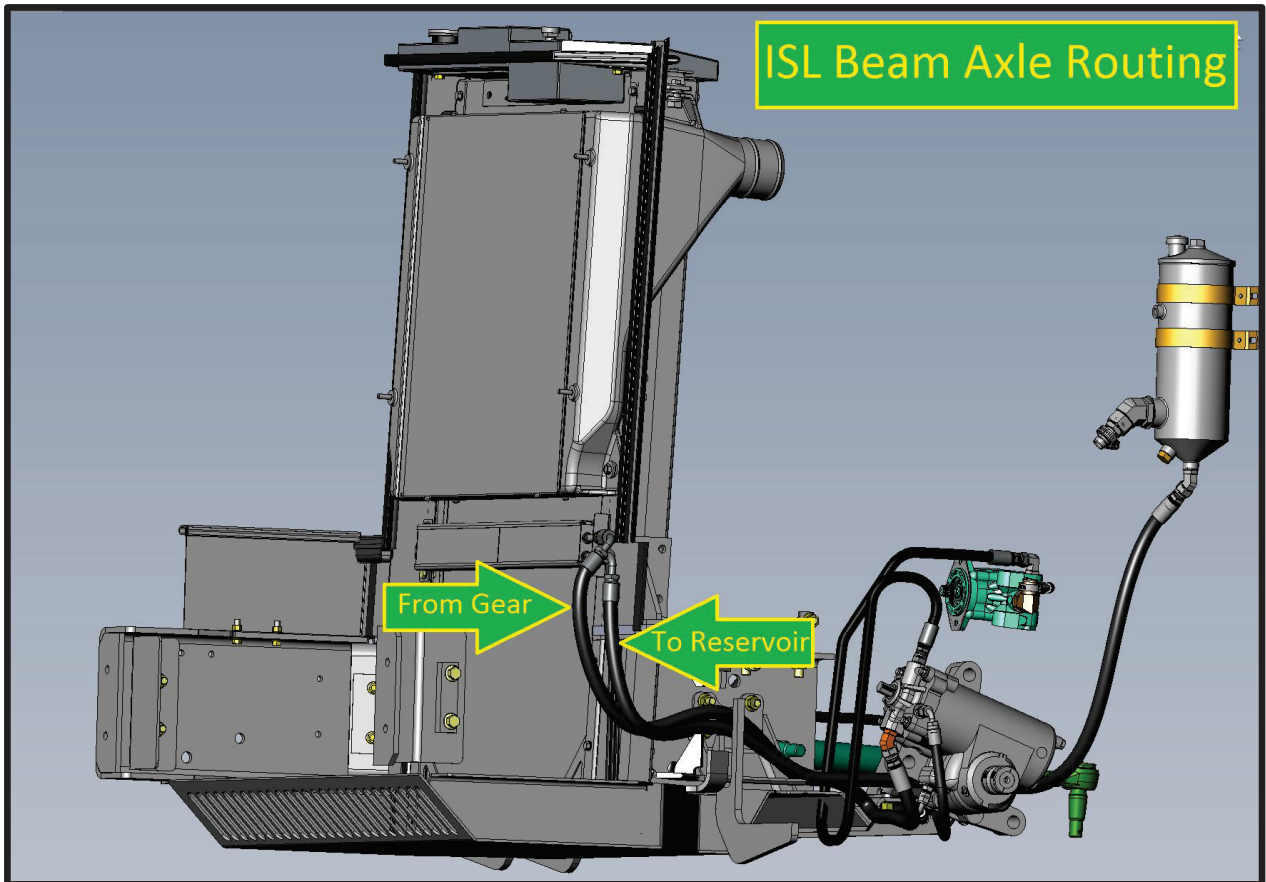
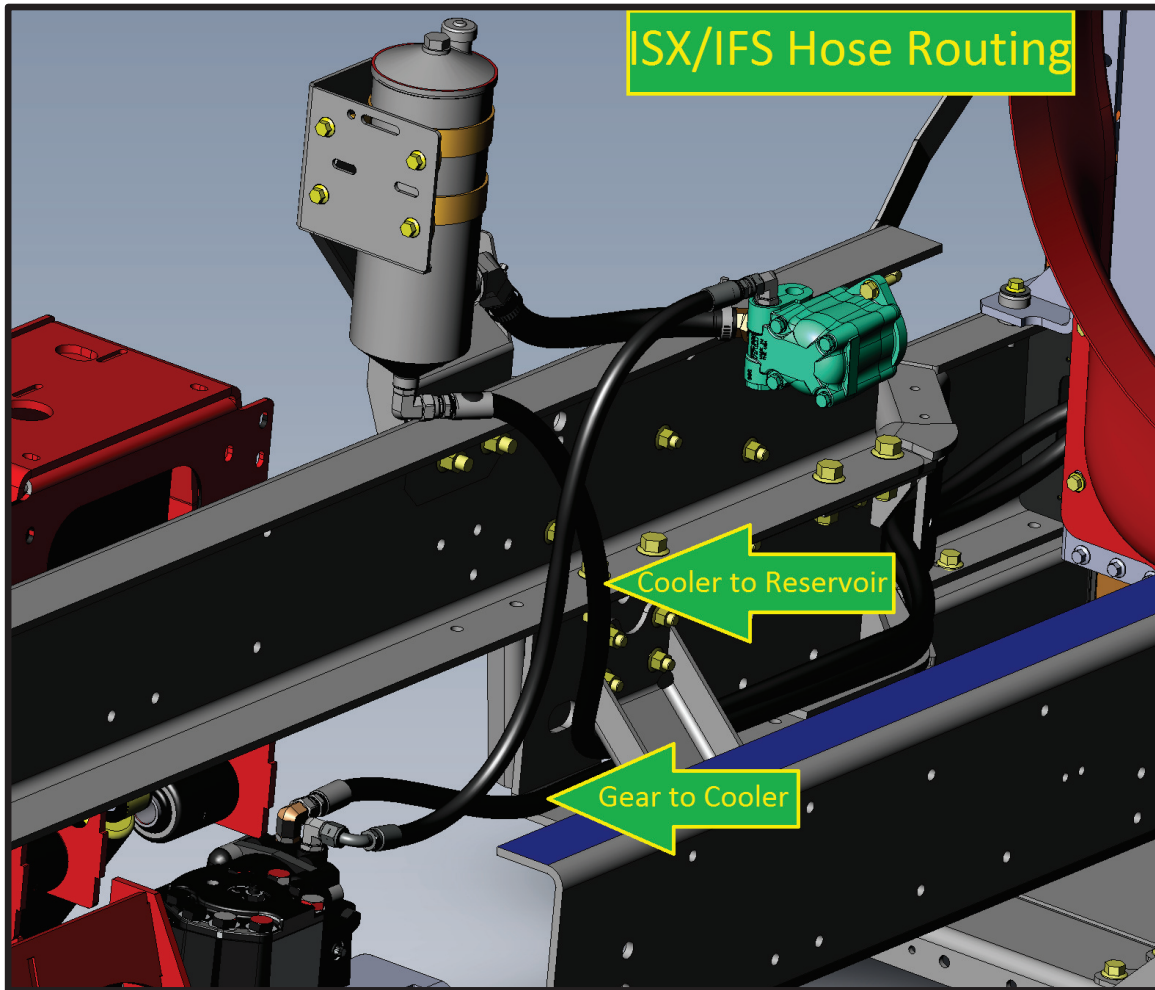

FIG. 7-1 - ISL Beam Axle Hose Routing Shown (ISX with Beam Axle is Similar)

Service Bulletins are intended for use by Professional Technicians only. They are written to guide Professional Technicians in performing service to vehicles of specific nature in conjunction with industry standards. Professional Technicians are appropriately trained on industry standards and have the tools and equipment to perform procedures safely and properly.



**FIG. 8-1 – ISX with IFS Hose Routing Shown
(ISL with IFS is similar)**

Service Bulletins are intended for use by Professional Technicians only. They are written to guide Professional Technicians in performing service to vehicles of specific nature in conjunction with industry standards. Professional Technicians are appropriately trained on industry standards and have the tools and equipment to perform procedures safely and properly.



Recall Service Bulletin



Filling and Air Bleeding the System

Tools Required	Materials Required
5/16" Socket Lbf·in. Torque wrench	Hydraulic fluid

CAUTION Make sure poppets are set correctly before beginning this procedure.

Run engine for 10 seconds, turn off and fill reservoir

1. Fill the reservoir nearly full. Do not steer. Start and run the engine for 10 seconds, then shut it off. Check and refill the reservoir. Repeat at least three times, checking the reservoir each time.

Hydraulic fluid

CAUTION Do not allow the fluid level to drop significantly or run out of the reservoir. This may induce air into the system.

Run engine for 2 minutes, turn off and fill reservoir

2. Start the engine and let it idle for 2 minutes. Do not steer. Shut off the engine and check the fluid level in the reservoir. Refill as required.

Hydraulic fluid

Steer vehicle

3. Start the engine again. Steer the vehicle from full left to full right several times. Add fluid, as necessary, to the full line on the dip stick.

Automatic bleed systems should now be free from trapped air. **Manual bleed systems continue with step 4.**

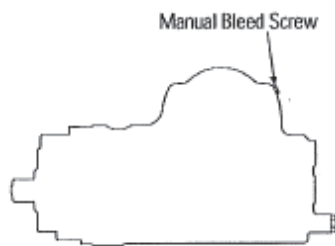
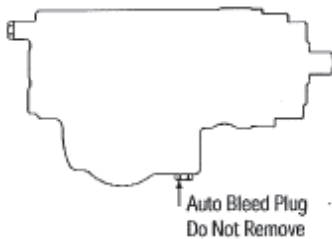

Allow air to bleed out from bleed screw

Lbf·in. Torque wrench
5/16" Socket

FIG. 9-1

Service Bulletins are intended for use by Professional Technicians only. They are written to guide Professional Technicians in performing service to vehicles of specific nature in conjunction with industry standards. Professional Technicians are appropriately trained on industry standards and have the tools and equipment to perform procedures safely and properly.



Recall Service Bulletin



If the fan clutch air supply line is disconnected follow the steps below to reconnect. If not, disregard steps 10-13.

10. Remove the cap from the 90° fitting at the fan clutch solenoid. Refer to FIG. 10-1.

11. Remove the plug from the fan clutch to clutch solenoid airline. Refer to FIG. 10-1.

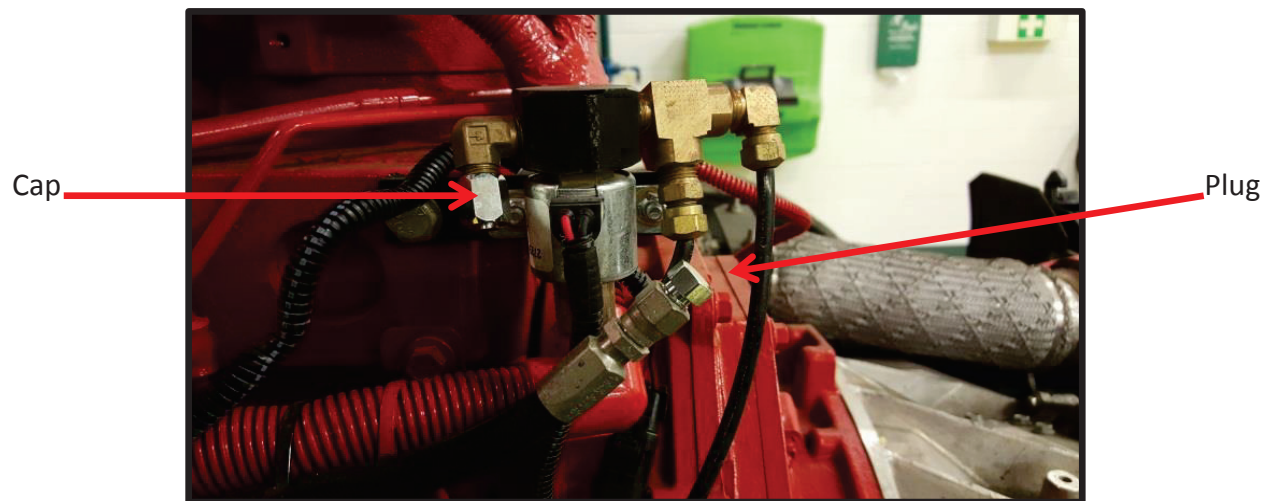

FIG. 10-1

Service Bulletins are intended for use by Professional Technicians only. They are written to guide Professional Technicians in performing service to vehicles of specific nature in conjunction with industry standards. Professional Technicians are appropriately trained on industry standards and have the tools and equipment to perform procedures safely and properly.



Recall Service Bulletin



12. Attach the airline shown in Figure 12-1 to the fan clutch solenoid. Tighten fitting to 2 FFWR (Flats From Wrench Resistance) Refer to FIG 11-1.



FIG. 11-1

13. Start the engine to ensure proper fan clutch operation.

Service Bulletins are intended for use by Professional Technicians only. They are written to guide Professional Technicians in performing service to vehicles of specific nature in conjunction with industry standards. Professional Technicians are appropriately trained on industry standards and have the tools and equipment to perform procedures safely and properly.