

Product Safety Recall

54180 Misrouted Fuel Line



Reference Number: N16205418
GWM Number: 2054180

Release Date: August 2016
Revision: 00

Attention: It is a violation of Federal law for a dealer to deliver a new motor vehicle or any new or used item of motor vehicle equipment (including a tire) covered by this notification under a sale or lease until the defect or noncompliance is remedied.

All involved vehicles that are in dealer inventory must be held and not delivered to customers, dealer traded, or used for demonstration purposes until the repair contained in this bulletin has been performed on the vehicle.

Make	Model	Model Year		RPO	Description
		From	To		
Buick	Verano	2016	2016	LHU	2.0L Turbo Engine

Involved vehicles are marked “open” on the Investigate Vehicle History screen in GM Global Warranty Management system. This site should always be checked to confirm vehicle involvement prior to beginning any required inspections and/or repairs.

Condition	General Motors has decided that a defect, which relates to motor vehicle safety, exists in certain 2016 model year Buick Verano vehicles equipped with the 2.0 liter turbocharged (LHU) engine. The engine fuel line assembly in these vehicles may have been manufactured incorrectly, causing the fuel line to be misrouted over the engine surface during vehicle assembly. Misrouted fuel lines may contact the hot surface of the turbocharged engine, which may degrade and wear the fuel line’s outer surface. If fuel lines contact the hot engine surfaces, the fuel line material may degrade and fail, causing fuel to leak and increasing the risk of an engine fire.
Correction	Dealers will replace the fuel line assembly.

Parts

Quantity	Part Name	Part No.
1	Fuel Feed Pipe	13371878
1	Fuel and Brake Pipe Heat Shield Retainer	13272003
1	Charge Air Cooler Inlet Air Tube Adapter Seal	13265351
2	Exhaust Pipe Front Hangar Bracket Bolt	11588723
2	Front Suspension Support Bolt	11561374
1	Brake and Fuel Pipe Clip	13396088

Parts required to complete this recall are to be obtained from General Motors Customer Care and Aftersales (GMCC&A). Please refer to your “involved vehicles listing” before ordering parts. Order parts on a CSO = Customer Special Order only. DRO’s may be cancelled. **All orders will be reviewed prior to being filled.** Parts may have quantity limiters in effect.

Important: Due to limited initial parts availability, dealers are encouraged not to order recall parts for use as shelf stock.

Warranty Information

Labor Operation	Description	Labor Time	Trans. Type	Net Item
9102481	Fuel Feed Pipe Replacement	2.3	ZFAT	N/A

Product Safety Recall

54180 Misrouted Fuel Line



Service Procedure

The service procedure outlined in this bulletin is different than the procedure listed in SI for fuel feed pipe replacement – underbody.

1. Open the hood and install fender covers.
2. Disconnect the negative battery cable. Refer to *Battery Negative Cable Disconnection and Connection* in SI.
3. Remove the engine sight shield. Refer to *Engine Sight Shield Replacement* in SI.
4. Release the fuel pressure. Refer to *Fuel Pressure Relief* in SI.
5. Remove the charge air cooler inlet hose. Refer to *Charge Air Cooler Inlet Hose Replacement (Turbocharger)* in SI.

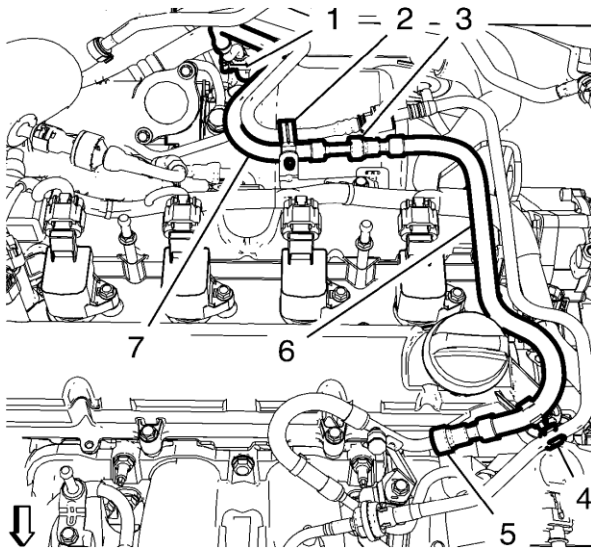

2743726

6. Unclip the fuel feed pipe (7) from the retainer clip (2).
7. Disconnect the fuel feed pipe - front (6) at the connector (3) from the fuel feed pipe - underbody (7). Refer to *Metal Collar Quick Connect Fitting Service* in SI.
8. Close the fuel feed pipe connectors with CH-6015 plugs.
9. Remove the air cleaner outlet duct. Refer to *Air Cleaner Outlet Duct Replacement* in SI.

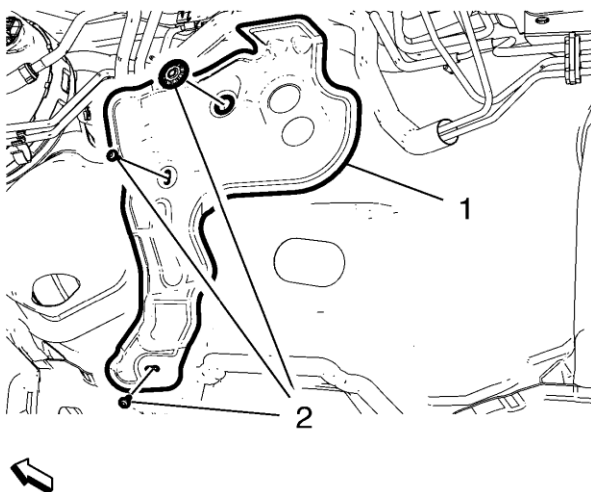

2743383

Product Safety Recall 54180 Misrouted Fuel Line



10. Remove the brake and fuel pipe heat shield retainers (2).
11. Reposition the brake and fuel pipe heat shield (1) to gain access to the upper bulk head clip.

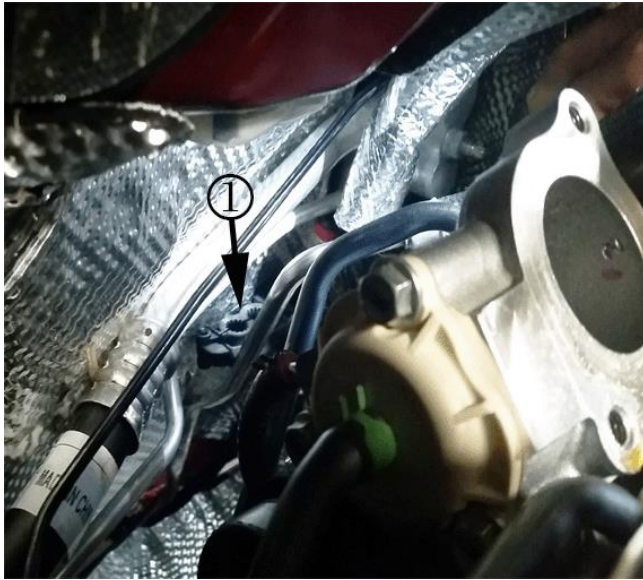

4571773

12. Open the upper bulk head clip (1).
13. Remove the fuel feed pipe from the upper bulkhead clip.
14. Raise and support the vehicle. Refer to *Lifting and Jacking the Vehicle* in SI.
15. Place a suitable jack under the rear of the drivetrain and front suspension frame.

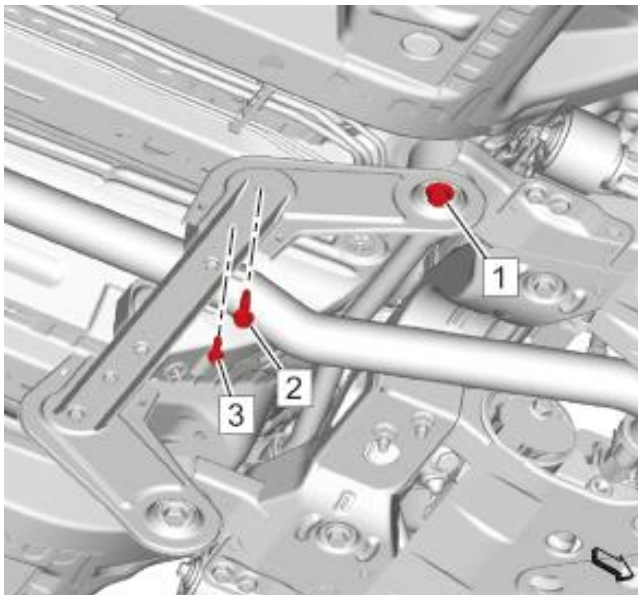

2538049

16. Remove and DISCARD the exhaust front hanger bracket bolts (3) from both sides.
17. Remove and DISCARD the frame reinforcement bolts (2) from both sides.
18. Remove the rear drivetrain and front suspension frame bolts (1) from both sides.
19. Remove the underbody front air deflector. Refer to *Underbody Front Air Deflector Replacement - Right Side* in SI.

Product Safety Recall

54180 Misrouted Fuel Line

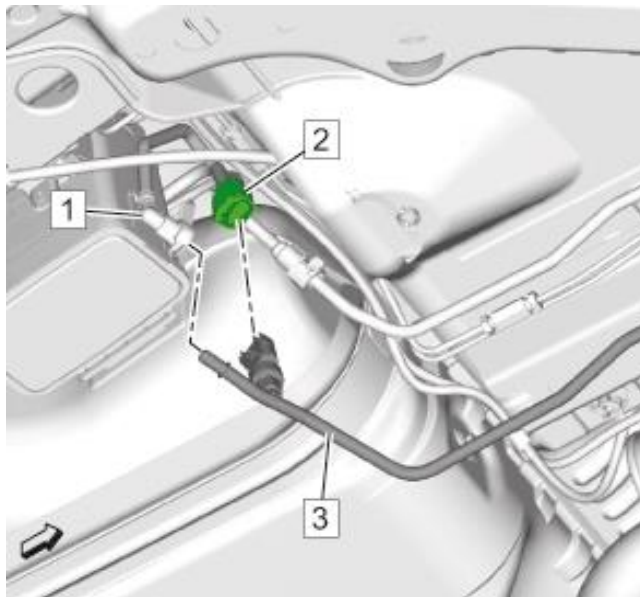

2834311

20. Disconnect the fuel feed pipe connector (1) from the fuel feed pipe - underbody (3). Refer to *Plastic Collar Quick Connect Fitting Service* in SI.
21. Close the fuel feed pipe and fuel tank feed pipe with *CH-6015* plugs.
22. Disconnect the fuel pressure sensor wiring harness plug (2) from the fuel pressure sensor.

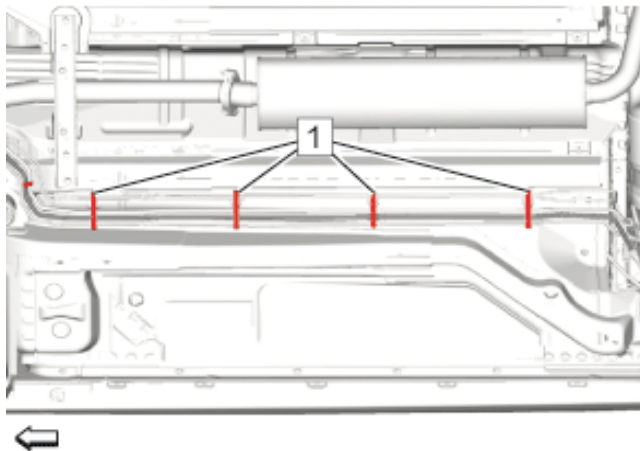

2191622

23. Open the 4 fuel feed pipe clips (1) retaining the fuel feed pipe to the body.

Product Safety Recall 54180 Misrouted Fuel Line



4571775

24. Open the lower bulk head clip (1).
25. Lower the rear of the drivetrain and suspension frame to gain clearance to remove the fuel feed pipe.
26. Remove the fuel feed pipe.



4572135

27. Verify the protective sleeve (1) is installed on the replacement fuel feed pipe.
 - If the protective sleeve is installed on the replacement fuel feed pipe, proceed to the next step.
 - If the protective sleeve is NOT installed on the replacement fuel feed pipe, scrap the fuel feed pipe and obtain a new one.
28. Install the new fuel feed pipe.
29. Jack the rear of the drivetrain and suspension frame back up into position.
30. Remove the *CH-6015* plugs from fuel feed tank pipe and fuel feed pipe.

Product Safety Recall 54180 Misrouted Fuel Line

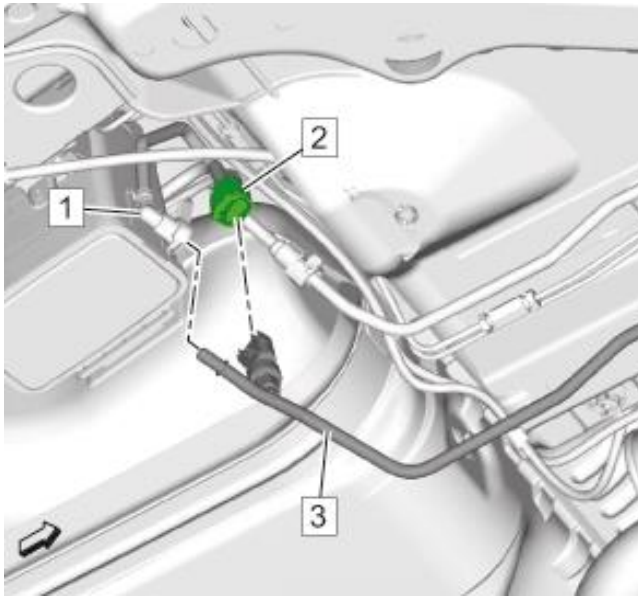

2834311

31. Connect the fuel feed pipe - tank (1) to the fuel feed pipe - underbody (3). Refer to *Plastic Collar Quick Connect Fitting Service* in SI.
32. Install the fuel pressure sensor wiring harness plug (2) to the fuel pressure sensor.



4571775

33. Route the fuel feed pipe into the lower bulk head clip (1) and close the clip.

Product Safety Recall 54180 Misrouted Fuel Line

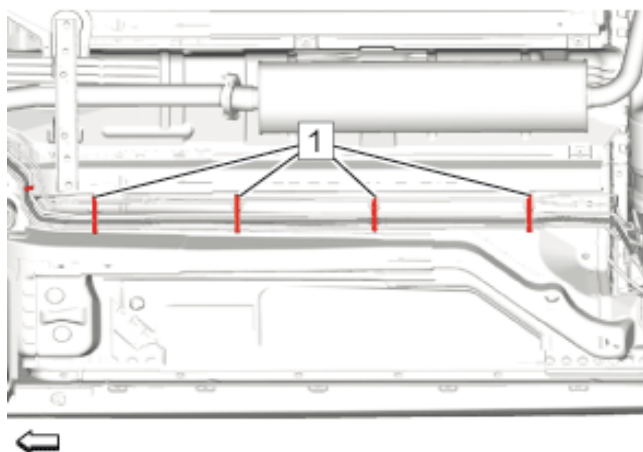

2191622

34. Route the fuel feed pipe into the fuel feed pipe clips (1) and close the clips.
35. Install the underbody front air deflector. Refer to *Underbody Front Air Deflector Replacement - Right Side* in SI.

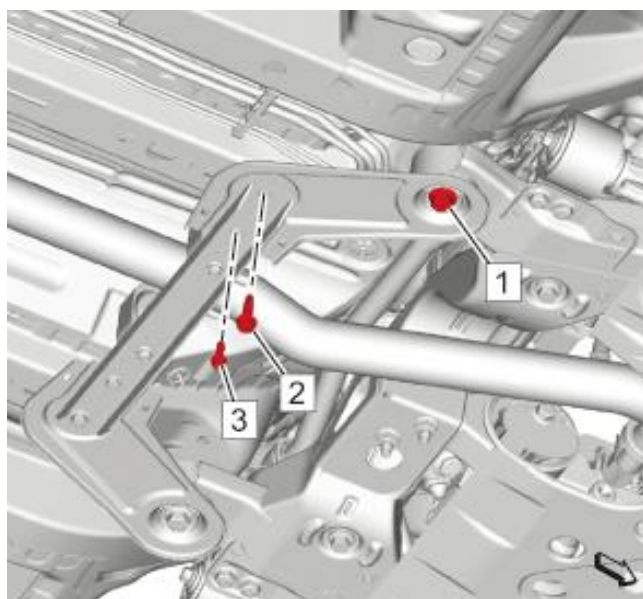

2538049

Caution: Use the correct fastener in the correct location. Replacement fasteners must be the correct part number for that application. Do not use paints, lubricants, or corrosion inhibitors on fasteners, or fastener joint surfaces, unless specified. These coatings affect fastener torque and joint clamping force and may damage the fastener. Use the correct tightening sequence and specifications when installing fasteners in order to avoid damage to parts and systems. When using fasteners that are threaded directly into plastic, use extreme care not to strip the mating plastic part(s). Use hand tools only, and do not use any kind of impact or power tools. Fastener should be hand tightened, fully seated, and not stripped.

36. Install both of the rear drivetrain and front suspension frame bolts (1) and tighten to 160 Nm (118 lb ft).
Caution: This vehicle is equipped with torque-to-yield or single use fasteners. Install a NEW torque-to-yield or single use fastener when installing this component. Failure to replace the torque-to-yield or single use fastener could cause damage to the vehicle or component.
37. Install both of the NEW the frame reinforcement bolts (2) and tighten to 60 Nm (44 lb ft).
38. Install both of the NEW exhaust front hanger bracket bolts (3) and tighten to 22 Nm (16 lb ft).

Product Safety Recall 54180 Misrouted Fuel Line



39. Remove the jack that was placed under the rear of the drivetrain and front suspension frame.
40. Lower the vehicle. Refer to *Lifting and Jacking the Vehicle* in SI.

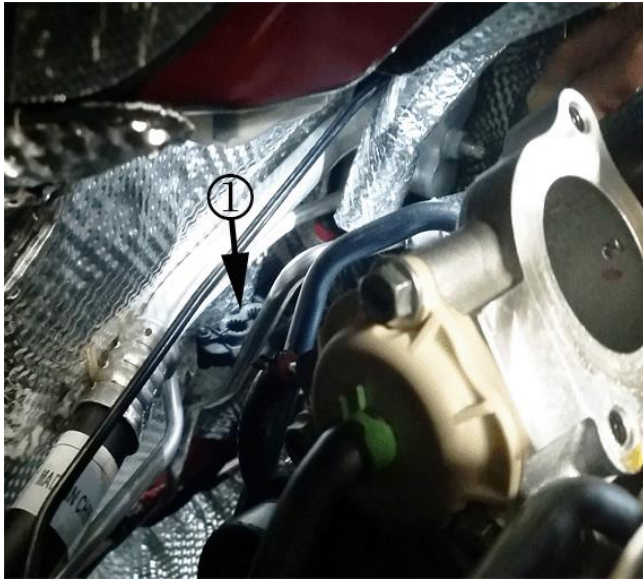

4571773

41. Install the fuel feed pipe into the upper bulkhead clip (1) and close the clip.

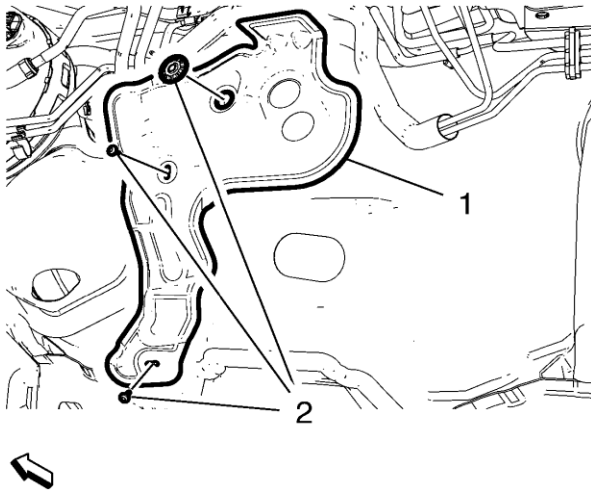

2743383

42. Reposition the brake and fuel pipe heat shield (1) back to its original location.
43. Install the brake and fuel pipe heat shield retainers (2).
44. Install the air cleaner outlet duct. Refer to *Air Cleaner Outlet Duct Replacement* in SI.
45. Remove the *CH-6015* plugs from the fuel lines.

Product Safety Recall

54180 Misrouted Fuel Line

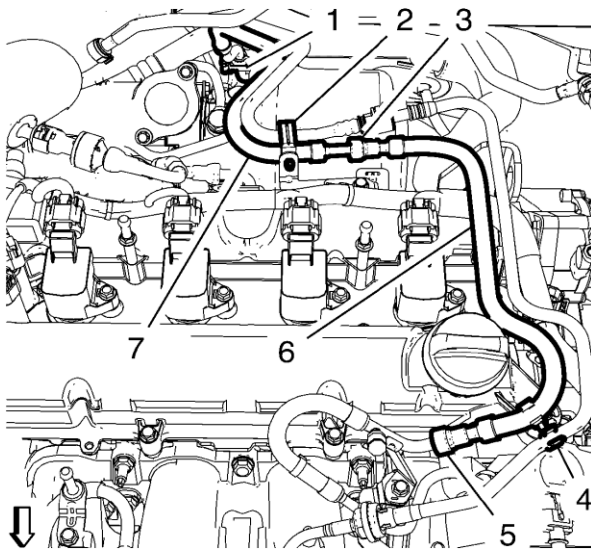

2743726

46. Install the fuel feed pipe (7) to the retainer clip (2).
47. Connect the fuel feed pipe - front (6) at the connector (3) to the fuel feed pipe - underbody (7). Refer to *Metal Collar Quick Connect Fitting Service* in SI.
48. Install the charge air cooler inlet hose. Refer to *Charge Air Cooler Inlet Hose Replacement (Turbocharger)* in SI.
49. Install the engine sight shield. Refer to *Engine Sight Shield Replacement* in SI.
50. Connect the negative battery cable. Refer to *Battery Negative Cable Disconnection and Connection* in SI.
51. Cycle the ignition ON to pressurize the fuel system and inspect the fuel feed pipe for fuel leaks.
52. Remove fender covers and close hood.

Dealer Responsibility – For USA & Export (USA States, Territories, and Possessions)

It is a violation of Federal law for a dealer to deliver a new motor vehicle or any new or used item of motor vehicle equipment (including a tire) covered by this notification under a sale or lease until the defect or noncompliance is remedied.

The US National Traffic and Motor Vehicle Safety Act provides that each vehicle that is subject to a recall of this type must be adequately repaired within a reasonable time after the customer has tendered it for repair. A failure to repair within sixty days after tender of a vehicle is prima facie evidence of failure to repair within a reasonable time. If the condition is not adequately repaired within a reasonable time, the customer may be entitled to an identical or reasonably equivalent vehicle at no charge or to a refund of the purchase price less a reasonable allowance for depreciation. To avoid having to provide these burdensome remedies, every effort must be made to promptly schedule an appointment with each customer and to repair their vehicle as soon as possible. In the recall notification letters, customers are told how to contact the US National Highway Traffic Safety Administration if the recall is not completed within a reasonable time.

Product Safety Recall

54180 Misrouted Fuel Line



Dealer Responsibility – All

All new, used, GM Certified Used, courtesy transportation vehicles, dealer shuttle vehicles, etc. in dealers' possession and subject to this recall must be held and inspected/repaired per the service procedure of this bulletin before customers take possession of these vehicles. Involved vehicles must be held and not delivered to customers, dealer-traded, released to auction, used for demonstration, or any other purpose.

All GM Certified Used vehicles currently in the dealers' inventory within the Certified Pre-Owned Inventory System (CPOIS) will be de-certified and must be held and remedied per the service procedure in this bulletin. Upon submitting an accepted/paid warranty transaction in the Global Warranty Management (GWM) system, the vehicle can be re-certified for sale within the CPOIS system, or once again be used in the CTP program.

Dealers are to service all vehicles subject to this recall at no charge to customers, regardless of mileage, age of vehicle, or ownership, from this time forward.

Customers who have recently purchased vehicles sold from your vehicle inventory, and for which there is no customer information indicated on the dealer listing, are to be contacted by the dealer. Arrangements are to be made to make the required correction according to the instructions contained in this bulletin. Recall follow-up cards should not be used for this purpose, since the customer may not as yet have received the notification letter.

In summary, whenever a vehicle subject to this recall enters your vehicle inventory, or is in your dealership for service in the future, you must take the steps necessary to be sure the recall correction has been made before selling or releasing the vehicle.

Dealer Reports

For dealers with involved vehicles, a listing with involved vehicles has been prepared and will be provided to U.S. and Canadian dealers through the GM GlobalConnect Recall Reports, or sent directly to export dealers. The listing may contain customer names and addresses obtained from Motor Vehicle Registration Records. The use of such motor vehicle registration data for any purpose other than follow-up necessary to complete this recall is a violation of law in several states/provinces/countries. Accordingly, you are urged to limit the use of this report to the follow-up necessary to complete this recall.

Courtesy Transportation – For USA & Canada

Courtesy transportation is available for customers whose vehicles are involved in a product program and still within the warranty coverage period. See General Motors Service Policies and Procedures Manual, Section 6.1.10 – Courtesy Transportation, for details.

Customer Notification

USA & Canada - General Motors will notify customers of this recall on their vehicle

Export - Letters will be sent to known owners of record located within areas covered by the US National Traffic and Motor Vehicle Safety Act.

