

Bulletin Type.....: Safety Recall

Bulletin No.....: TS-S112

Bulletin Name.....: Steel Rims Offset Improvement

Bulletin Ref.No....: 700002856

NHTSA.....: 16V-591

Release Date.....: 09.19.2016

Expiry Date.....: -

Vehicle Model.....: TS45

Flat Rate Code.....: 60 min.

Subject: Steel Rims Offset Improvement

Summary: This bulletin is prepared to replace the current steel rims of the drive axle with the new ones on TS45 vehicles.

Bulletin Responsible.....: Serhat Celepci

Published by & Approved by...: Hakan Günerdem

Welding on the Chassis

- Always disconnect the batteries (starting with the negative lead).
- Disconnect the connectors of electrical and electronic equipment (electronic control units, sensors and actuators) if they are less than 20 inches away from the chassis part to be welded or the earth terminal of the welding equipment.
- The earth terminal should never be attached to vehicle components such as engine, axles and springs. Arcing on these parts is not permitted, because of the risk of damage to bearings, springs, etc.
- The earth terminal must make good contact and be placed as close as possible to the part to be welded.
- Plastic pipes, rubber parts and parabolic springs should be well protected against welding spatter and temperatures higher than 70°.
- The contact switch must not be in the accessory or contact position. The contact key should be removed.
- Reconnect in reversed order of disconnecting. Ensure that a good earth connection is made between chassis, engine and cab.

Service bulletin expiry dates differ according to service bulletin type.

Definitions

Release Date: As of this date the bulletin is released and available on E-Doc. Modification parts can be ordered. The time period between the release date and the effective date may vary according to the procurement lead time.

Effective Date: As of this date specified amount of the total modification parts will be available on Spare Parts Stock. Modification parts can be ordered and the application can be performed. (except non-compliance and safety related campaigns, i.e. S-Type Bulletin)

Part Order Deadline: Last order date for modification parts. The part orders which will be placed after this date should be approved by Regional Coordinator.

Expiry Date: Expiration date for the application.

Bulletin Types

- **S-Type:** Application period of this bulletin is 18 months after the date of issue. S type bulletin is used for Recall Campaigns.



- **U-Type:** Application period of this bulletin is 12 months after the date of issue. U type bulletin is used for updates that need to be performed upon customer complaints.

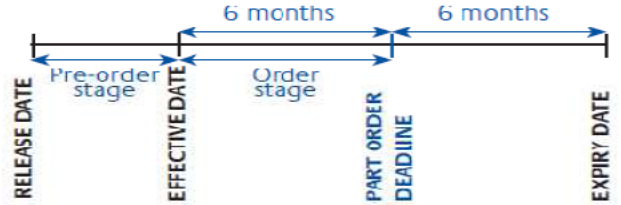

- **C-Type:** Application period of this bulletin is 12 months after the date of issue. C type bulletin is generally used for supplying technical instructions or other type of information to service network.

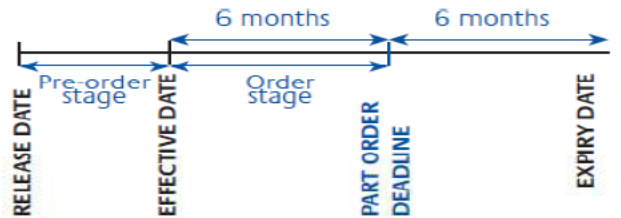

- **M-Type:** Application period of this bulletin is 12 months after the date of issue. M type bulletin is used for updates that should be implemented without waiting for customer complaints.

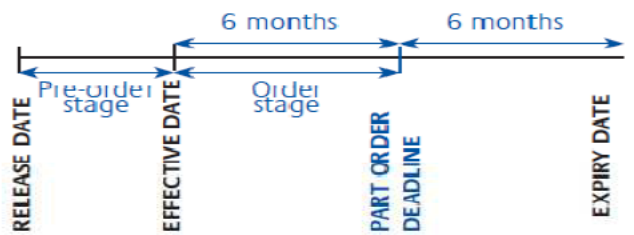

PART LIST

Installed Part List

No	Part No	Part Name	Qty	Picture
1	RP303116Y	STEEL RIM 22.5x9.00	4	

Excluded Part List

No	Part No	Part Name	Qty	Picture
1	TC808776-41Y	STEEL RIM 22,5x9.00	4	

GENERAL PRECAUTIONS

1. Suggested Dress Code:

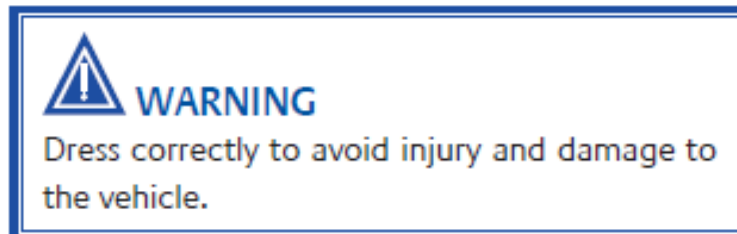

2. Before Starting the Work:

Always wear protective clothing. Do not wear any damaged or loose-fitting clothing and remove jewelry before starting the work. In case of long hair use hairnet. The illustration below shows some of the correct on incorrect clothing that should be worn during work. Sharp edges should be avoided e.g belts, watches, necklaces to prevent catching the vehicle.

3. Interior materials protection:

Seats, trimming, upholstery stuff and carpeting should be protected with appropriate coverings.

TECHNICAL INSTRUCTIONS

Application-1: Tire Removal Procedure

* Lift the vehicle up by using jack, from a jack point shown in Figure-1.

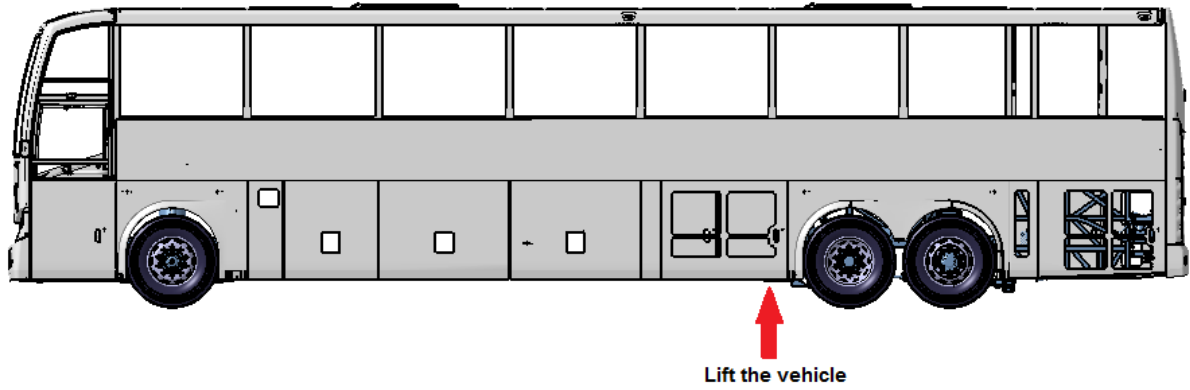

Figure-1

* Remove all the wheel nuts shown in Figure-2.

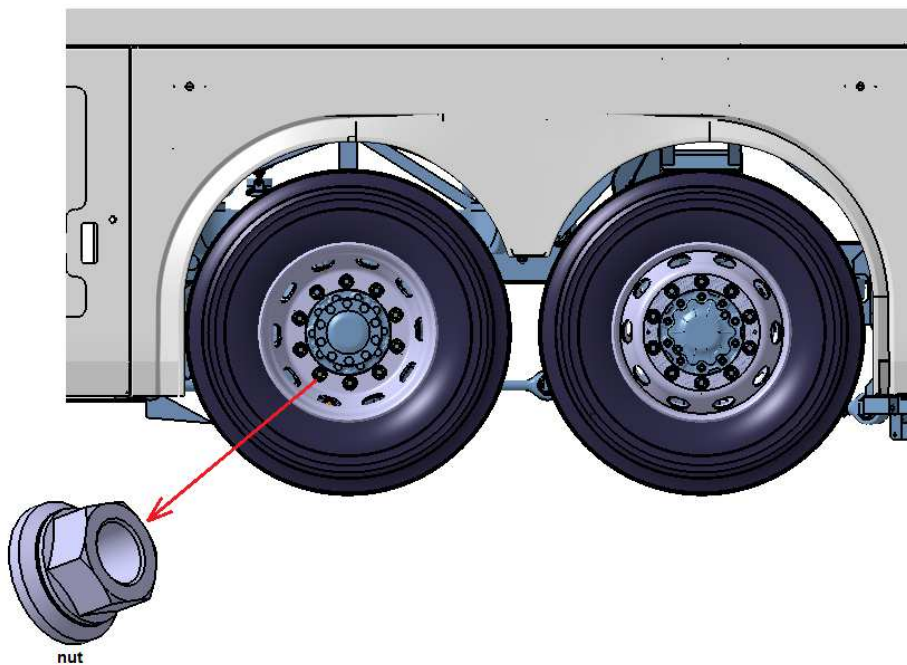

Figure-2

* Remove dual wheels from drive axle shown in Figure-3.

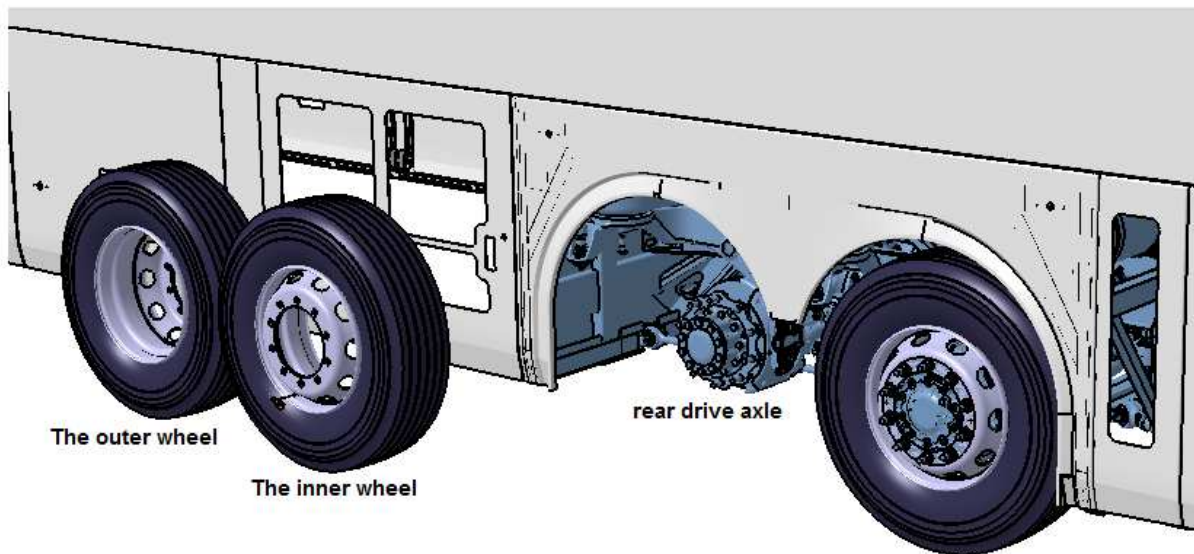

Figure-3

Application-2: Subassembly Procedure

* Remove the existing rims (TC808776-41Y) from the wheels shown in Figure-4.



Figure-4

SERVICE BULLETIN

* Remove the hose - valve extension from the inner rim shown in Figure-5.

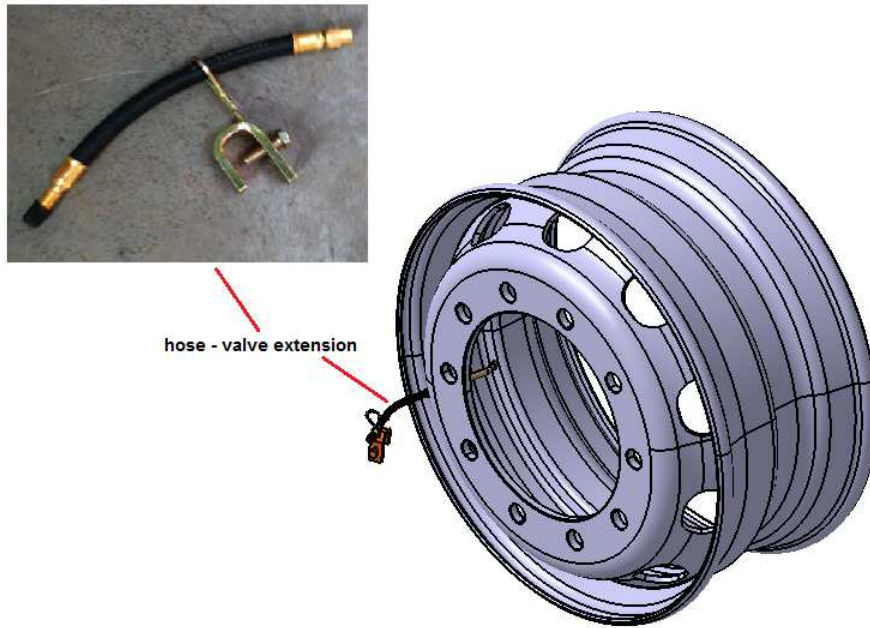

Figure-5

* Install hose - valve extension to the new inner rim shown in Figure-6.

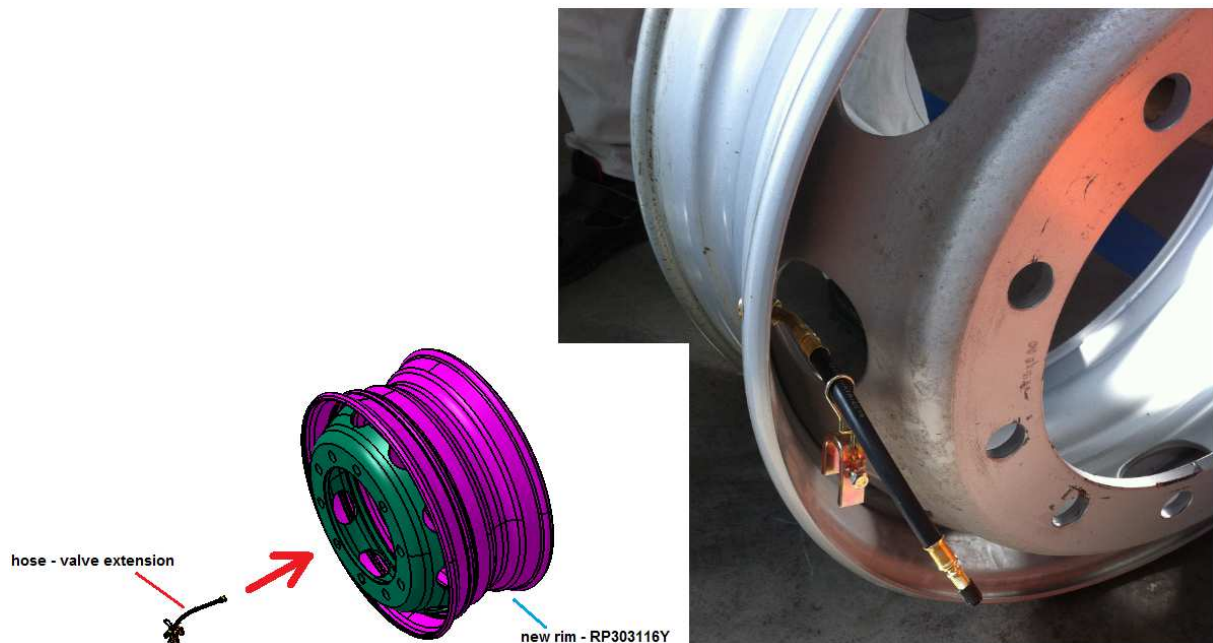
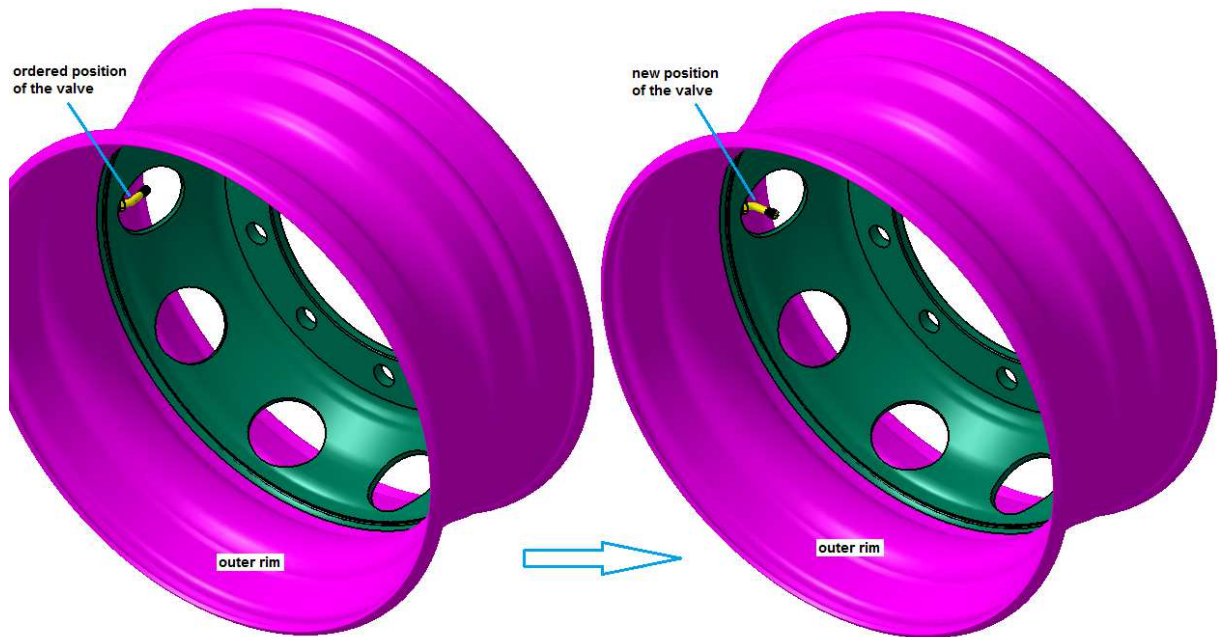

Figure-6

Note : The valve available on the outer rim should be positioned according to the inflating angle as shown in the picture below;



* Install new rims to the wheels shown in Figure-7.

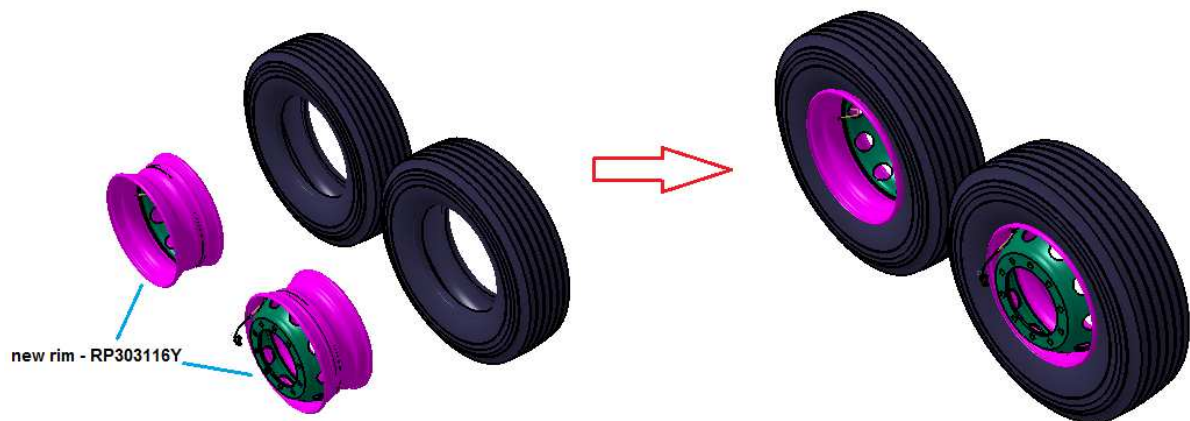

Figure-7

Note : After installing the new rims, all drive axle tires must be balanced.

Application-3: Installation Procedure

* Install both wheels to the rear axle respectively shown in Figure-8.

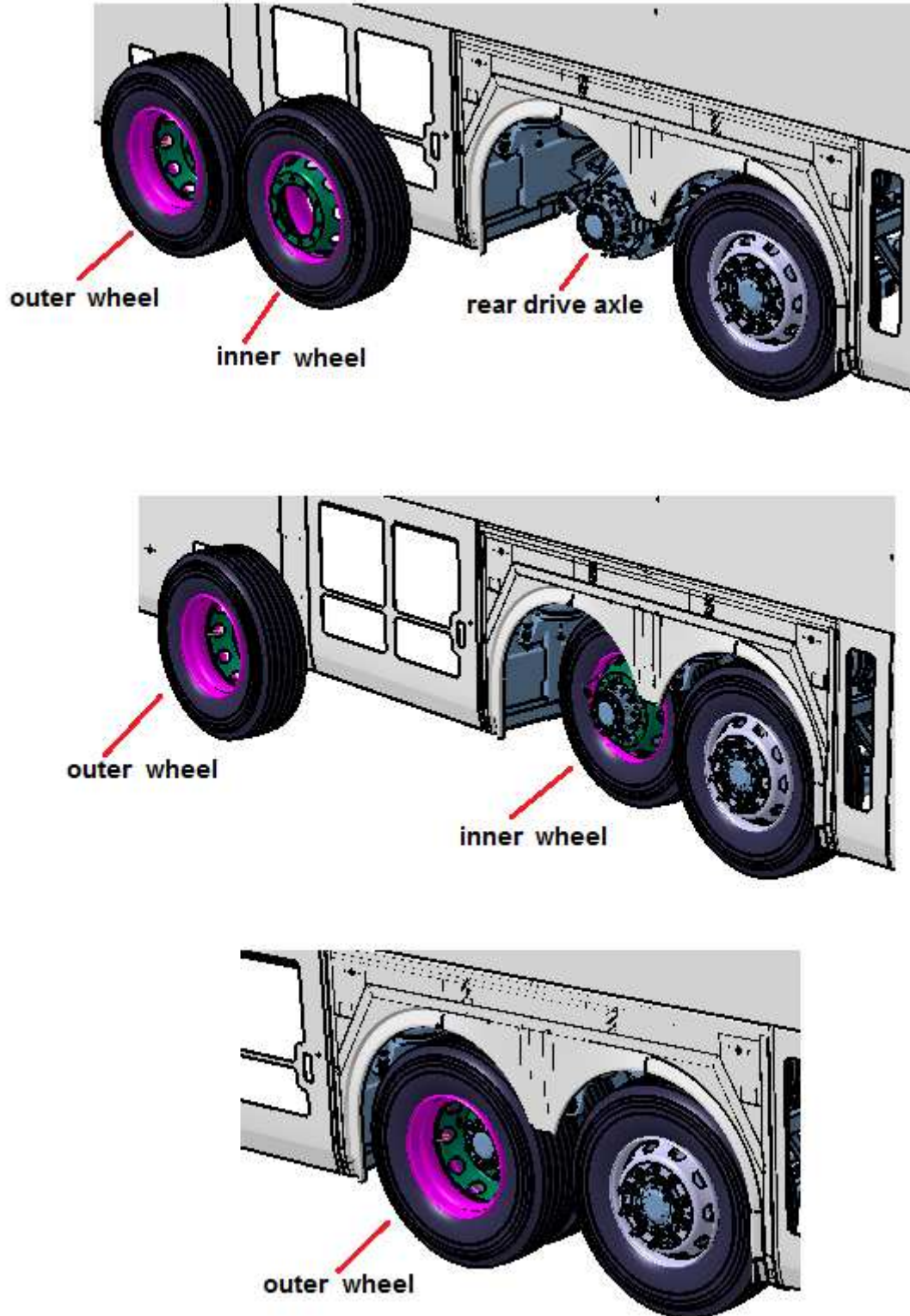
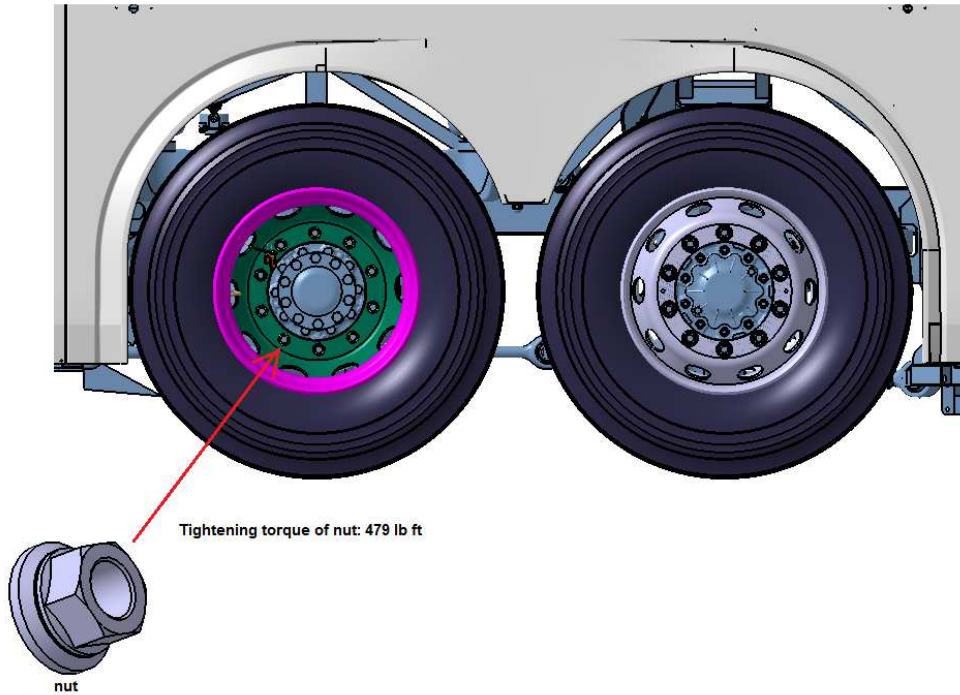

Figure-8

SERVICE BULLETIN

* Install and fix the nuts with the given tightening torque (479 lb ft) shown in Figure-9.



RATE BREAK DOWN

Application	Time
Application-1: Removal Procedure	30 min.
Application-3: Installation Procedure	30 min.
Total	60 min.

AFFECTED VEHICLE LIST

No	VIN	Country
1	NLTEJX	USA
2	NLTEJXU	USA
3	NLTEJXU	USA
4	NLTEJXU8	USA
5	NLTEJXU8	USA
6	NLTEJXX	USA
7	NLTEJXX	USA
8	NLTEJXX	USA
9	NLTEJXX	USA
10	NLTEJXX	USA
11	NLTEJXX	USA