



1199 Superleggera Clutch
Models: Model Year 2014 1199 Superleggera (all country versions)
Recall Bulletin SRV-RCL-16-002

Date: June 9, 2016
To: Dealer Principal, General Manager, Service Manager, North American Dealer Network
From: Richard Kenton, Technical Director; Jonathan LaForte, Technical Manager

Important: All Dealer Principals, Service Managers, and Parts Managers should read and initial this notice.

Dear Service Manager, this notice is sent to you in accordance with the requirements of the National Traffic and Motor Vehicle Safety Act.

NHTSA Campaign I.D. Number: 16V339
Transport Canada Safety Recall I.D. Number: 2016-247

Situation:



Based on the constant, ongoing product quality tests that Ducati performs, a potential issue concerning the clutch assembly of the Model Year 2014 1199 Superleggera has been identified. On certain motorcycles, the damper plate assembled between the primary driven gear and the clutch basket assembly may fatigue and break. If this occurs, part of the assembly could become displaced and could result in the engine stalling or lead to the rear wheel locking during motorcycle use. Analysis shows that this event may occur due to high and repeated stresses on the clutch assembly after heavy use of the motorcycle, such as during its use on track

Ducati has decided to replace the complete clutch assembly with a new one, increasing its reliability. Dealers will replace the clutch assembly with the re-designed component, which has already been adopted on the 1299 Panigale and Panigale R family.

In order to make this an amenable experience Ducati will provide the customer with an engine oil and filter cartridge replacement, potentially reducing the cost of the annual service. The costs of these two interventions will be fully borne by Ducati.

Affected VIN range requiring application of the technical solution:

You can find the precise list of VIN numbers involved in CR122 on the DCS, in sections:

VEHICLE HISTORY		You can consult the single frame number.
CAMPAIGNS		You can consult all the VIN numbers that Ducati Motor Holding sent you.



1199 Superleggera Clutch
Models: Model Year 2014 1199 Superleggera (all country versions)
Recall Bulletin SRV-RCL-16-002

Criteria for application of the technical solution on circulating motorcycles:

For the designated frame numbers referenced above, the motorcycles must be inspected.

Customer notification:

Ducati North America, Inc. will notify all known owners of affected vehicles directly by First Class mail. A sample copy of the owner notification letter is enclosed for your information.

Limitation on sale or lease of certain vehicles:

Section 154(d) of National traffic and Motor Vehicle Safety Act of 1996 mandates that dealers correct, prior to sale or lease, any vehicle which contains a defect relating to motor vehicle safety. It is therefore mandatory that any vehicle in your inventory affected by this recall be corrected prior to sale or lease.

Auto-ship replacement part:

Dealers will not receive an auto-ship order of part # 87211231A.

Service Solution:

Hereinafter is the list of all components required to carry out this intervention:

<i>Part no.</i>	<i>Description</i>	<i>Image</i>	<i>Qty.</i>
18920344A	Clutch Assembly		1
79710711A	Clutch Springs		3
85110201A	Safety washer		1
85250541A	Oil drain plug washer		1
44440312B	Oil filter cartridge		1
Not managed as spare part	Oil Shell Advance 4T Ultra 15W-50		4 litres



1199 Superleggera Clutch
Models: Model Year 2014 1199 Superleggera (all country versions)
Recall Bulletin SRV-RCL-16-002

- **Oil filter cartridge replacement Part no.44440312B**

- 1) Set the motorcycle on the rear service stand.
- 2) Remove ignition switch cover (See "Section 05 – Fairing – Headlight fairing" of the Workshop Manual).
- 3) Remove carbon RH and LH side covers (See "Section 05 – Fairing – Headlight fairing" of the Workshop Manual).
- 4) Remove RH side fairing (See "Section 05 – Fairing – Headlight fairing" of the Workshop Manual).
- 5) Remove LH side fairing (See "Section 05 – Fairing – Headlight fairing" of the Workshop Manual).
- 6) Remove **drain plug M14x1.5 (1)** with **washer (2)** from oil sump and drain oil.



NOTE

We suggest carrying out this operation with the engine hot and not running, as oil under these conditions is more fluid, and can thus be drained more quickly and completely.

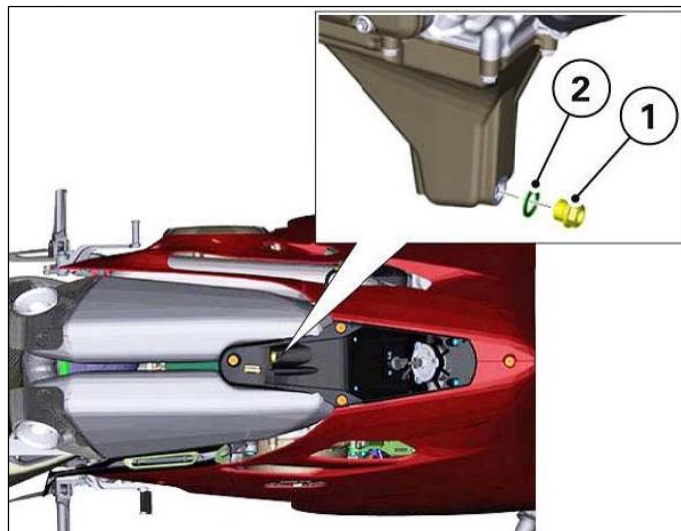



1199 Superleggera Clutch
Models: Model Year 2014 1199 Superleggera (all country versions)
Recall Bulletin SRV-RCL-16-002

- 7) Remove the **2 screws M6X20 (3)** securing **oil filter cover (4)**.

Remove **oil filter cover (4)** and **oil filter cartridge (5)**.



NOTE

We suggest protecting LH side silencer with a cloth so as to prevent oil residue from contacting the silencer.

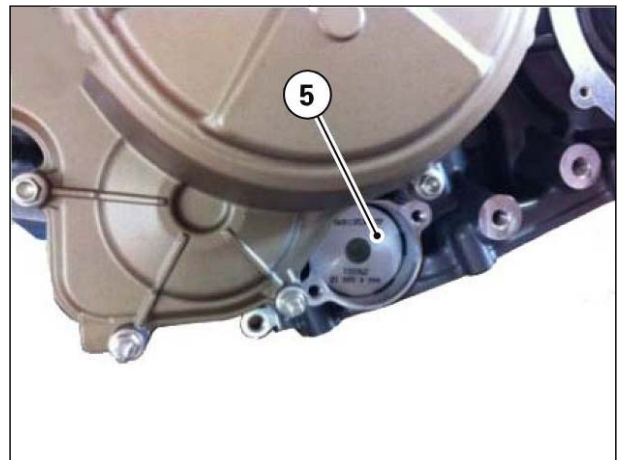
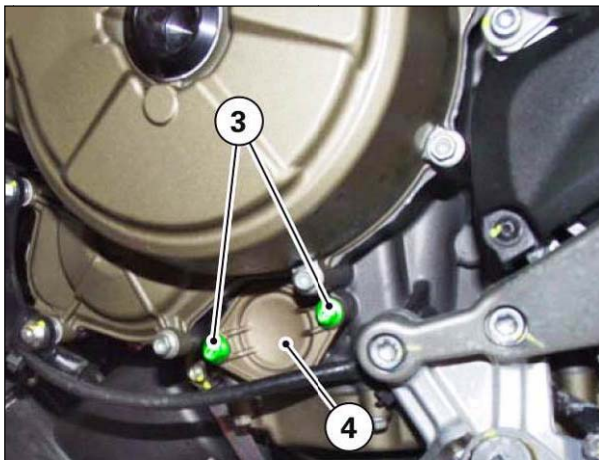

- 8) Install the new **oil filter cartridge Part no.44440312B** and fully secure.
9) Lubricate the 2 O-rings and fit **oil filter cover (4)** aiming it as shown in the figure.

Tighten the **2 screws M6X20 (3)** to a torque of **13 Nm ± 10%**.

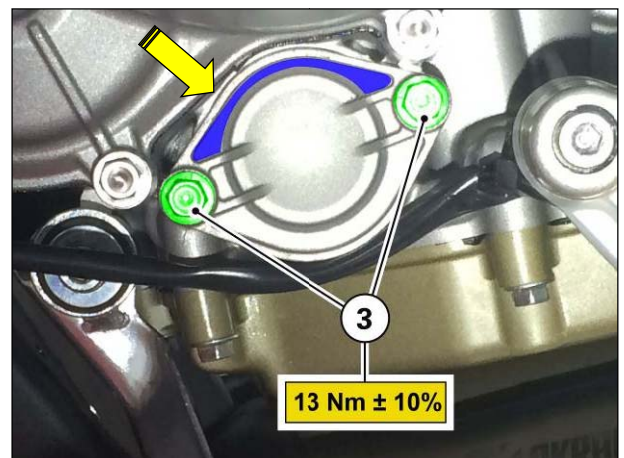
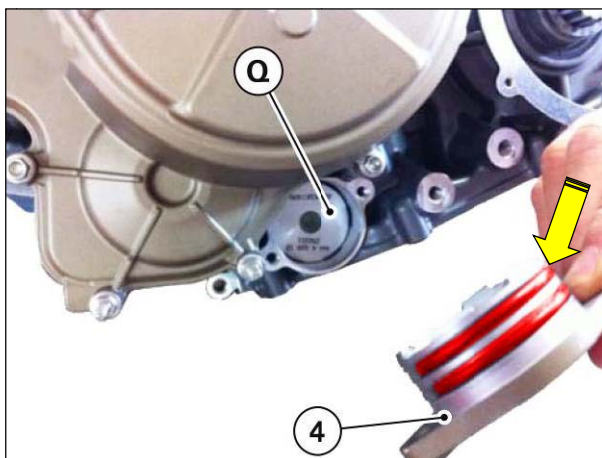



1199 Superleggera Clutch
Models: Model Year 2014 1199 Superleggera (all country versions)
Recall Bulletin SRV-RCL-16-002

- **Removal of the clutch assembly**

- 1) Loosen the **6 screws M6x25 (6)** and remove **clutch cover (7)** collecting the relevant O-ring.

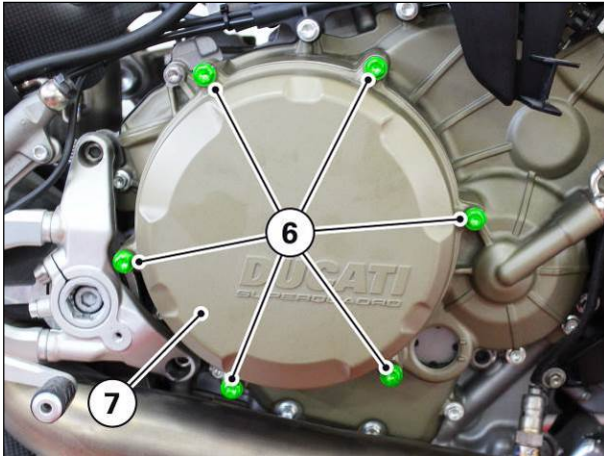

- 2) Remove the **3 screws M6x45 (8)** and take out the **3 caps (9)** and the **3 springs (10)** from **pusher plate (11)**.

Slide **pusher plate (11)** out.

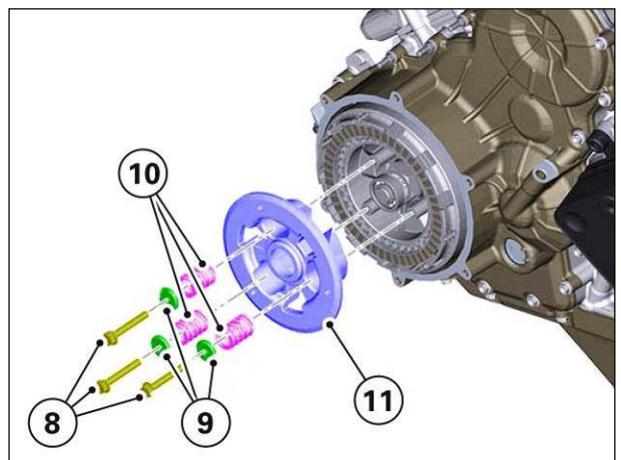
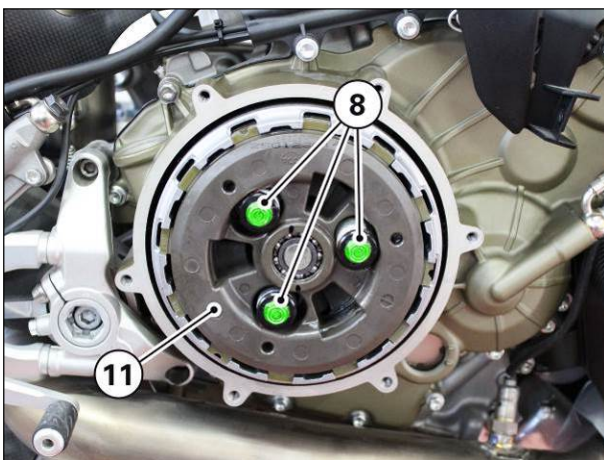



1199 Superleggera Clutch
Models: Model Year 2014 1199 Superleggera (all country versions)
Recall Bulletin SRV-RCL-16-002

- 3) Lock plate holder hub with special tool Part no.887133879 and tighten the **4 screws (12)** to a torque of **10 Nm ±10%**.

Remove retaining **nut M25x1.5 (13)**.

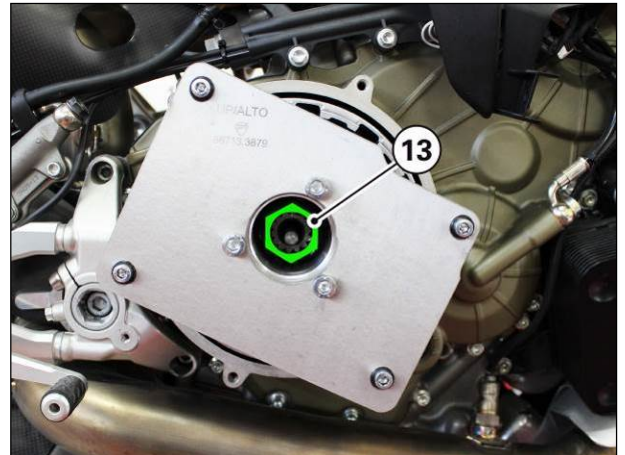
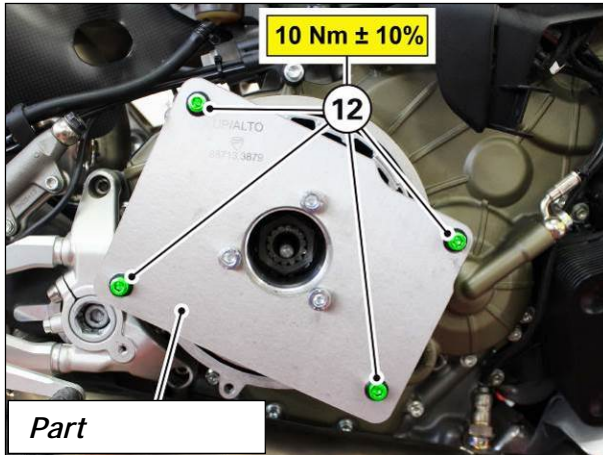

Then remove special tool Part no.887133879.

- 4) Slide out **lockwasher (14)** and **plate holder hub (15)** with the **clutch plate set (16)**.

Collect **belleville washer (17)** and **flat plate (18)**.

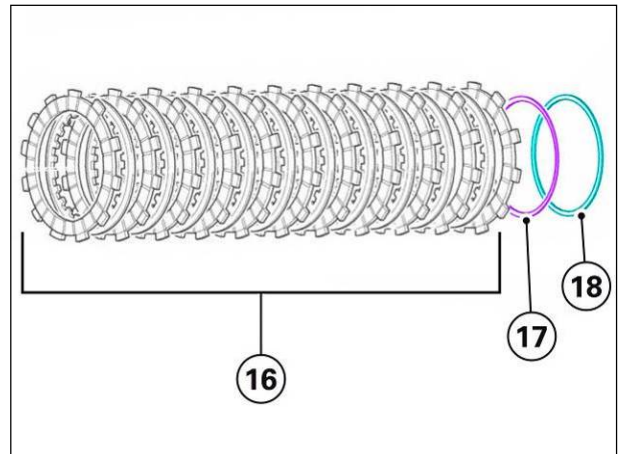
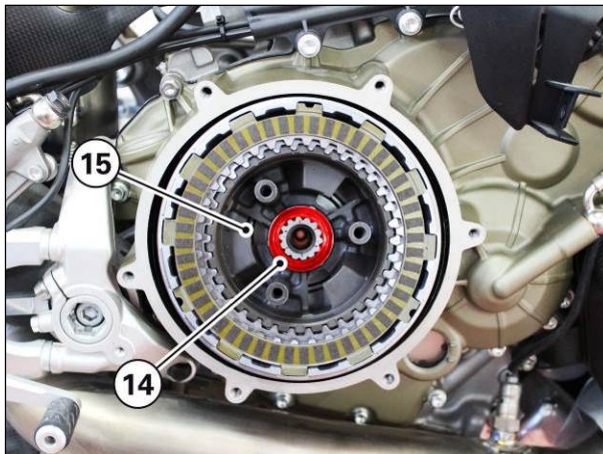



1199 Superleggera Clutch
Models: Model Year 2014 1199 Superleggera (all country versions)
Recall Bulletin SRV-RCL-16-002

- 5) Remove *spacer (19)* and *clutch housing (20)*.

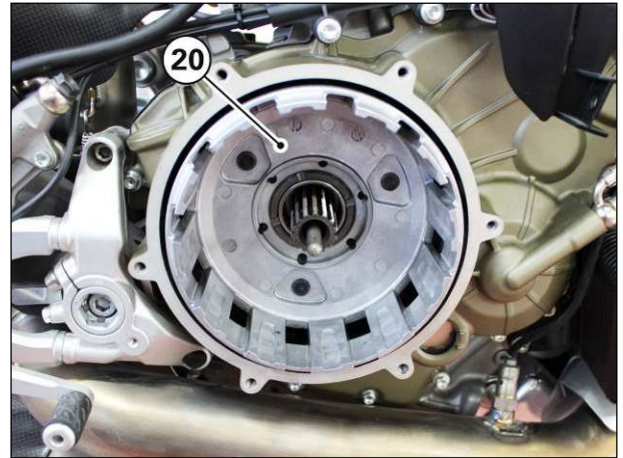
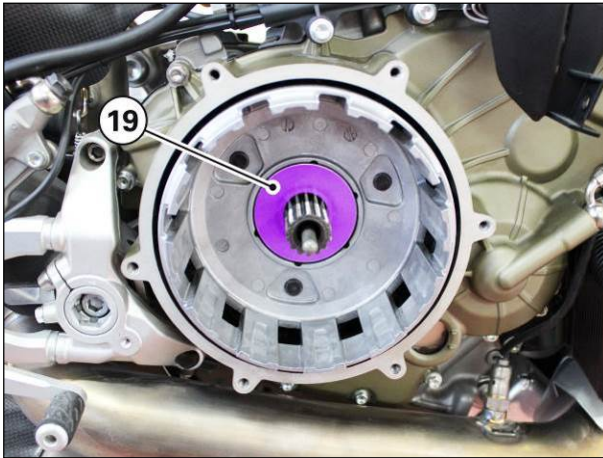

• *Assembling the new clutch assembly Part no.18920344A*

- 1) Remove *plug M27x1.5 (21)* from generator cover with the relevant *O-ring (22)*.

Fit special tool Part no. 887133824

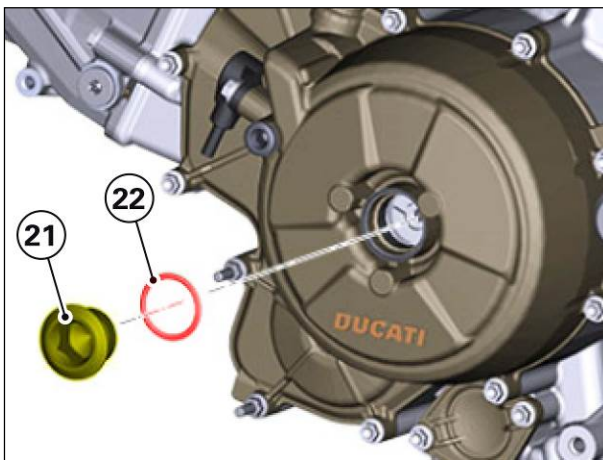



1199 Superleggera Clutch
Models: Model Year 2014 1199 Superleggera (all country versions)
Recall Bulletin SRV-RCL-16-002

- 2) Using special tool Part no.887133824, turn engine counter clockwise until primary drive sprocket **hole (23)** is visible, as shown in the figure.

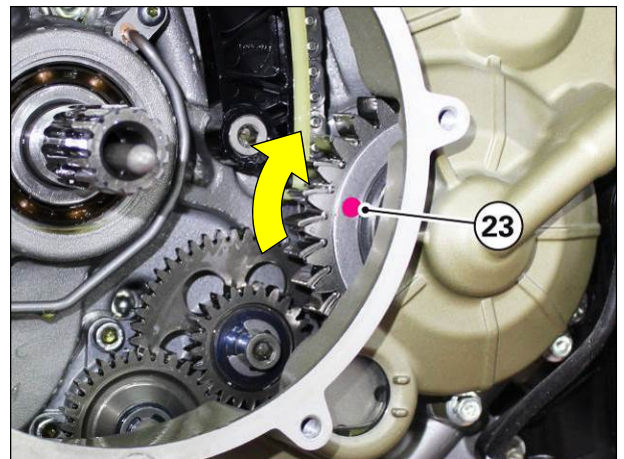
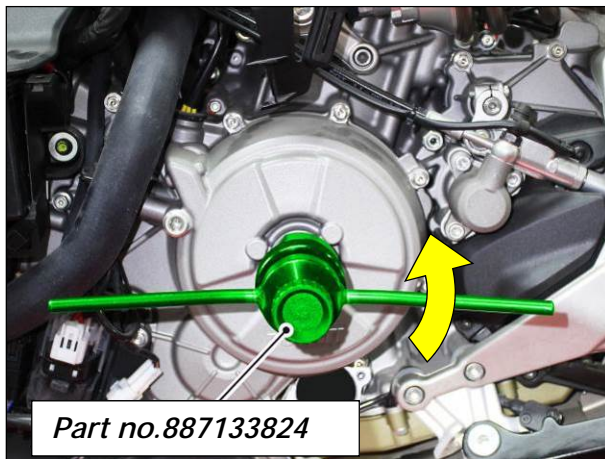

- 3) Collect **clutch plate pin (24)** from **pusher plate (11)** of the old clutch assembly.

Insert **clutch plate pin (24)** inside **pusher plate (D)** of the new clutch assembly Part no.18920344A, driving it fully home inside bearing.

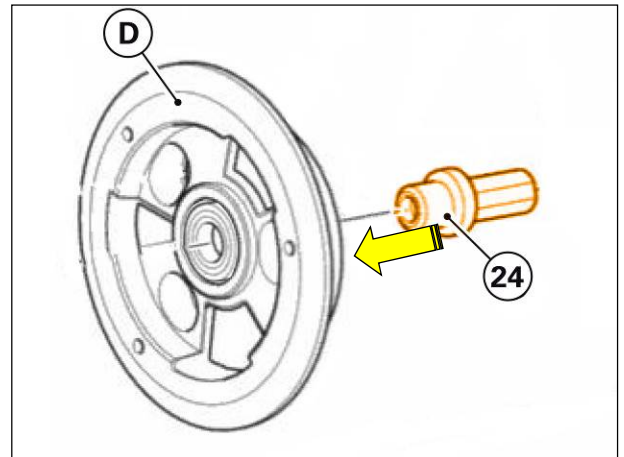
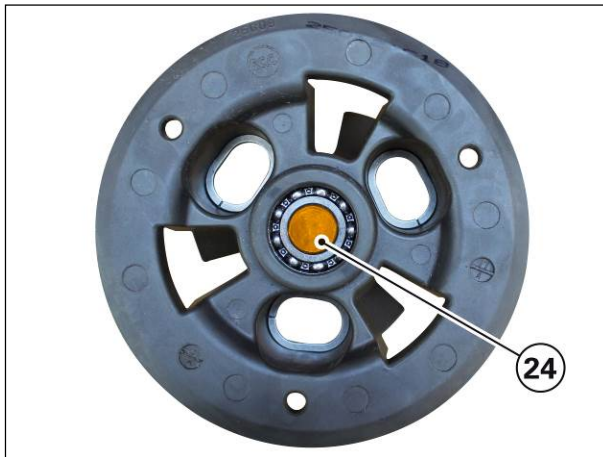



1199 Superleggera Clutch
Models: Model Year 2014 1199 Superleggera (all country versions)
Recall Bulletin SRV-RCL-16-002

- 4) Fit the new **bushing (F)** on gearbox primary shaft.

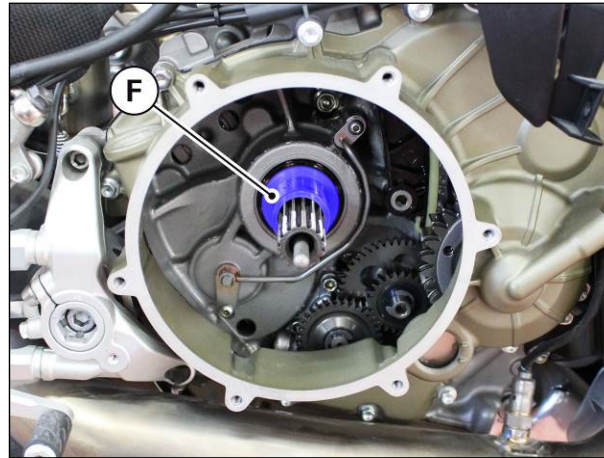

- 5) Disassemble the new clutch assembly Part no.18920344A.

Fit **clutch housing (M)** on gearbox primary shaft, driving teeth fully home on those of primary drive sprocket.

Insert a screwdriver inside primary drive sprocket **hole (23)** working from inside clutch housing.

Move screwdriver up until winning the force of primary drive sprocket twin disc teeth spring.

Then insert clutch housing assembly all the way down and remove screwdriver.

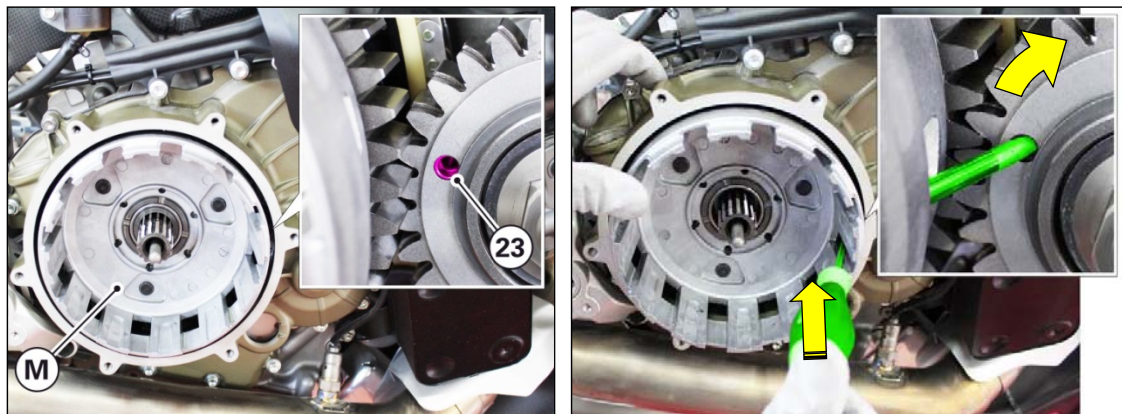



1199 Superleggera Clutch
Models: Model Year 2014 1199 Superleggera (all country versions)
Recall Bulletin SRV-RCL-16-002

6) Fit *spacer (E)* on clutch housing (M).

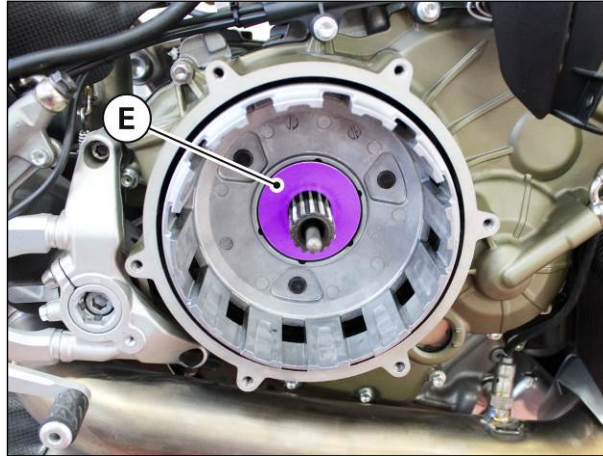

7) Position *flat plate (I)* and *belleville washer (H)* on *plate holder hub (L)* aiming it with the rounded side facing the drum.

Fit *plate holder hub (L)* and the NEW *lockwasher (O) Part no.85110201A* on gearbox primary shaft and start *retaining nut (13)*.

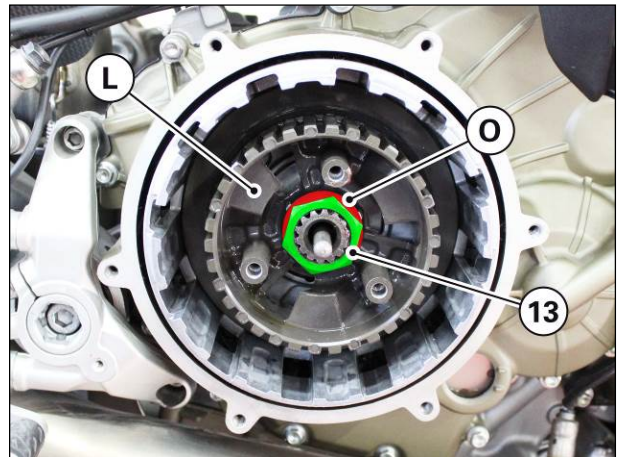
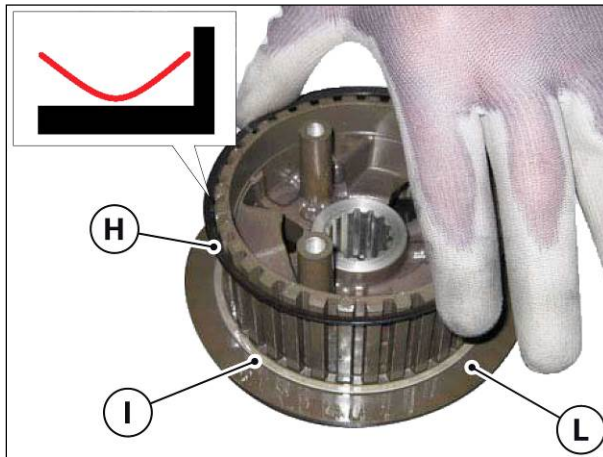



1199 Superleggera Clutch
Models: Model Year 2014 1199 Superleggera (all country versions)
Recall Bulletin SRV-RCL-16-002

- 6) Lock plate holder hub with special tool Part no.887133879 and tighten the **4 screws (12)** to a torque of **10 Nm ±10%**.

Tighten retaining **nut M25x1.5 (13)** to a torque of **190 Nm ±5%**.

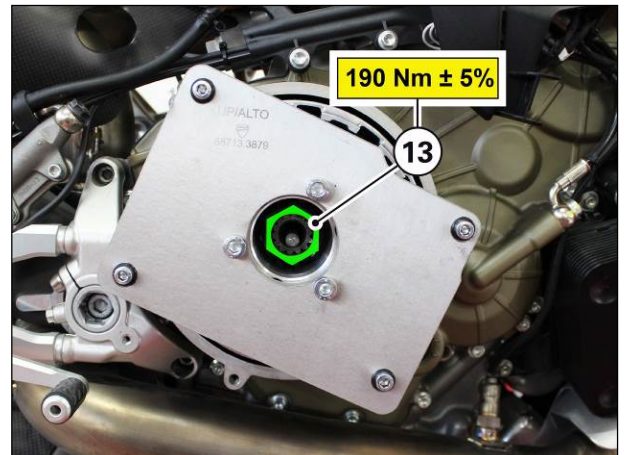
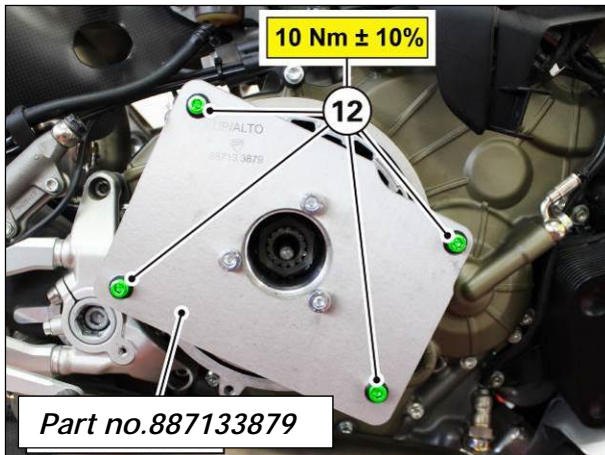

Remove special tool Part no.887133879.

- 7) Fit the clutch plate set (G) in the following order:

- on **plate holder hub (L)**:
set of 10 driving plates (X) alternated with nine driven plates (Y) starting from driving plate (X).
- on **pusher plate (D)**:
1 driving plate (X);
1 driven plate (Y).

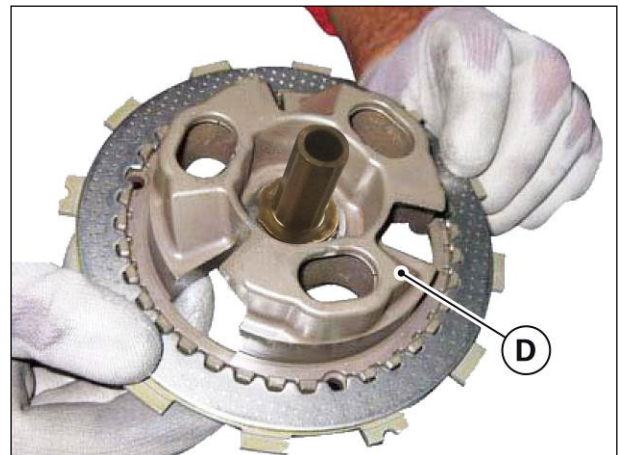
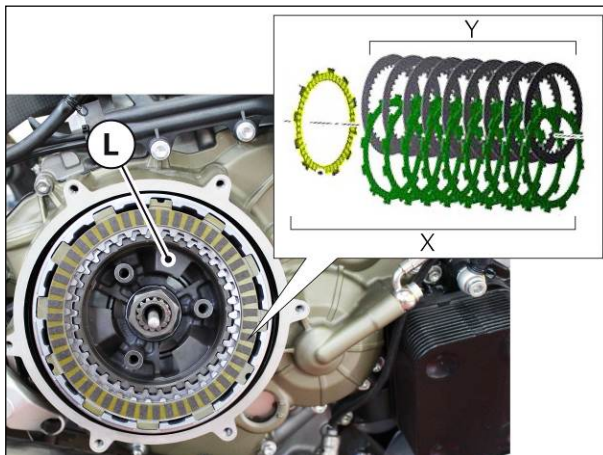



1199 Superleggera Clutch
Models: Model Year 2014 1199 Superleggera (all country versions)
Recall Bulletin SRV-RCL-16-002

- 8) Position **pusher plate (D)** with the two plates on centering tool Part no.887133352 and fit it on plate holder hub (L).

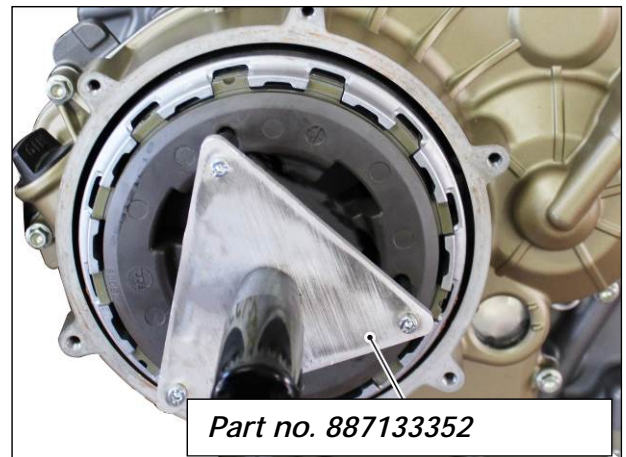
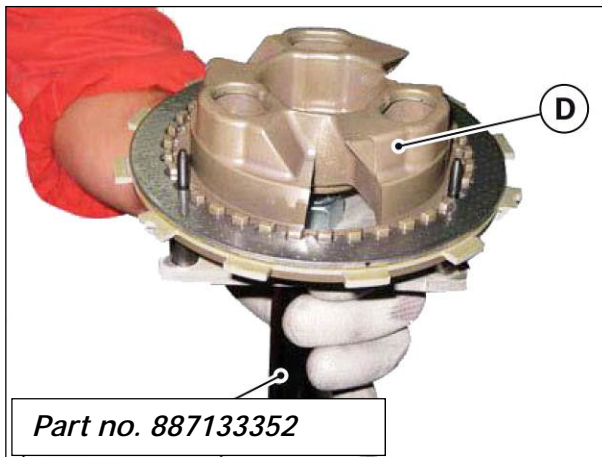

- 9) Ensure that the **3 shims (C)** are present on pusher plate.

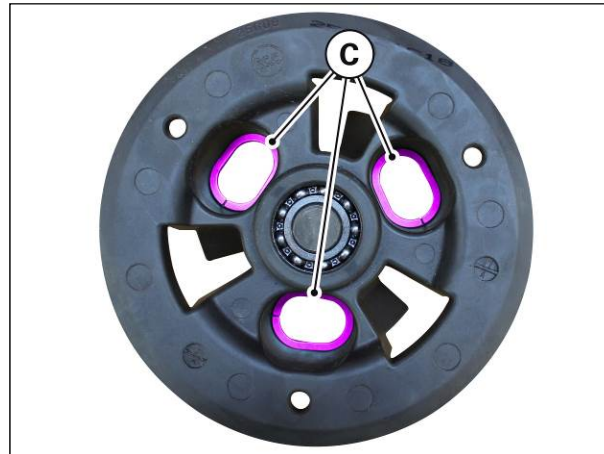



1199 Superleggera Clutch
Models: Model Year 2014 1199 Superleggera (all country versions)
Recall Bulletin SRV-RCL-16-002

- 10) Fit the **3 springs (N) Part no.79710711A**, the **guide ring (B)** and start the **3 screws M6x45 (A)**.

Tighten the **3 screws M6X45 (A)** to a torque of **10 Nm ± 10%**.

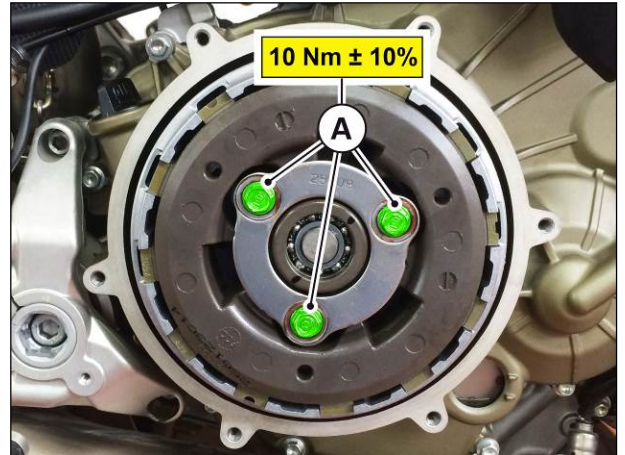
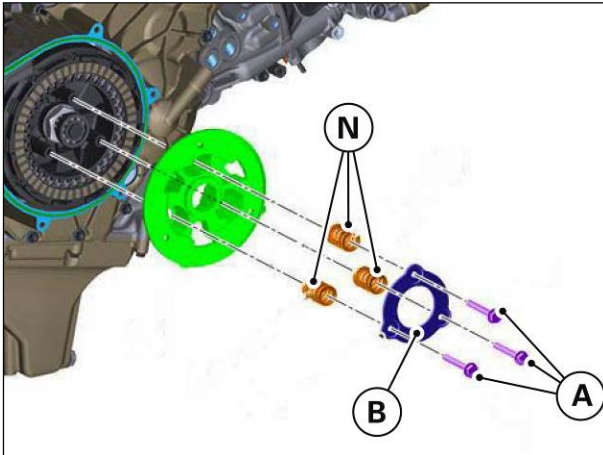

- 11) Fit clutch protection cover (7) by starting the **6 screws M6x25 (6)**.

Tighten the **6 screws M6X25 (6)** to a torque of **10 Nm ± 10%** following the indicated sequence.



WARNING

Ensure that the O-ring is positioned inside its seat on clutch protection cover (7).

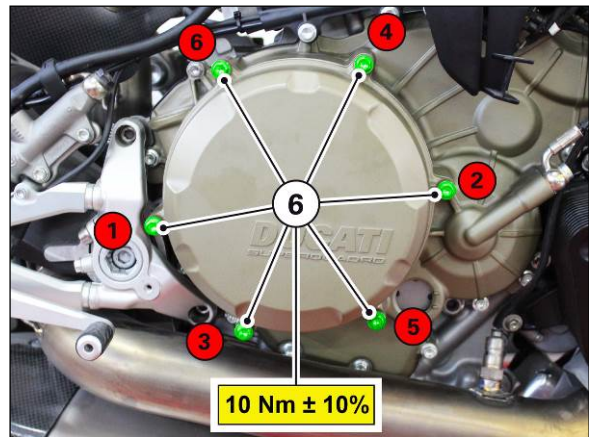



1199 Superleggera Clutch
Models: Model Year 2014 1199 Superleggera (all country versions)
Recall Bulletin SRV-RCL-16-002

- 8) Remove special tool Part no.887133824 and tighten generator cover **plug M27x1.5 (21)** with the relevant **O-ring (22)** to a torque of **27 Nm ±10%**.

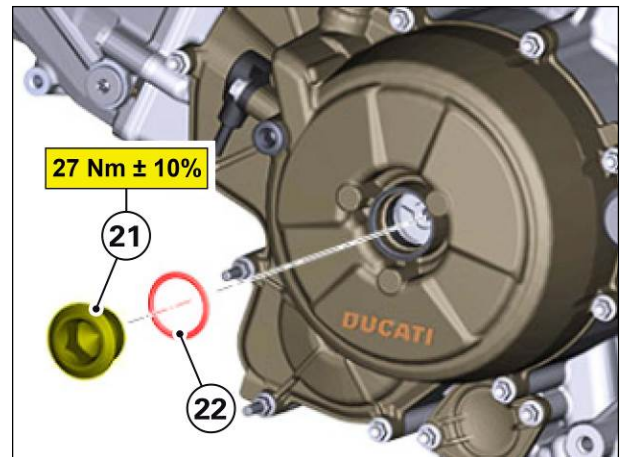
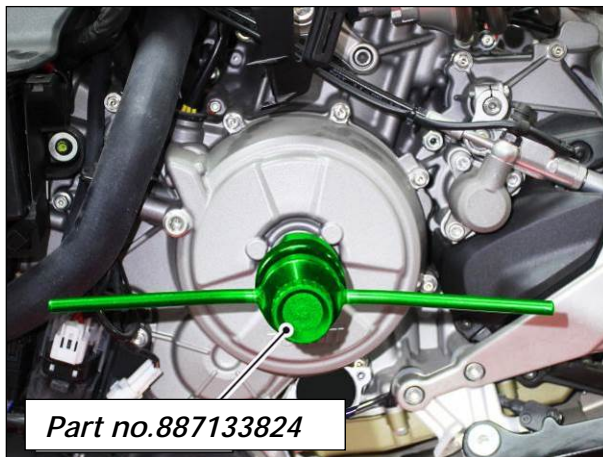

- 12) Before inserting the drain plug (1), you have to:
- dry the residual oil from inside the puller and perform a thorough cleaning;
 - ensure that there are no metal particles on drain plug magnetic end (1);
 - clean the whole threading of drain plug (1);
 - fit the **new washer (P) Part no.85250541A** aiming its flat surface towards the oil sump.
 - apply ThreeBond TB1215 along the whole threading of drain plug (1).

Tighten **drain plug M14x1.5 (1)** to a torque of **14 Nm ±10%**.

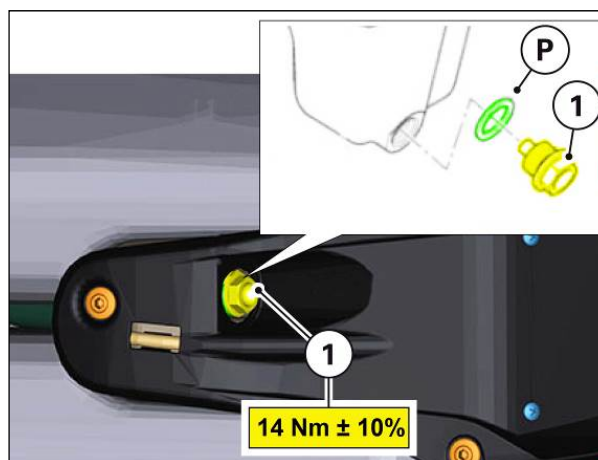



1199 Superleggera Clutch
Models: Model Year 2014 1199 Superleggera (all country versions)
Recall Bulletin SRV-RCL-16-002

- 13) Remove **filler plug M20x2.5 (24)** and add **NEW oil** until reaching the required level.
Insert **filler plug M20x2.5 (24)** and tighten it to a torque of **5 Nm \pm 5%**.

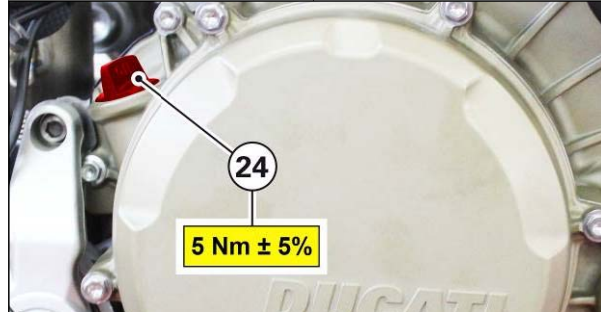

NOTE

Ducati recommends using Shell Advance 4T Ultra 15W-50 oil. As an alternative, you can use an oil with the same SAE 15W-50 grade, and in compliance with the JASO specifications: MA2 and API: SM.

Start the engine and let it heat up for a few minutes so as to let oil circulate. Check oil level and, if too low, top up.

- 14) Fit right side fairing by inserting **teeth (25)** behind electrical component support profile and **tabs (26)** inside vibration damping pads.

Move the right fairing towards the rear side of the vehicle making sure that the front profile of the fairing fits on the front profile of the radiator support, as shown by the arrow.

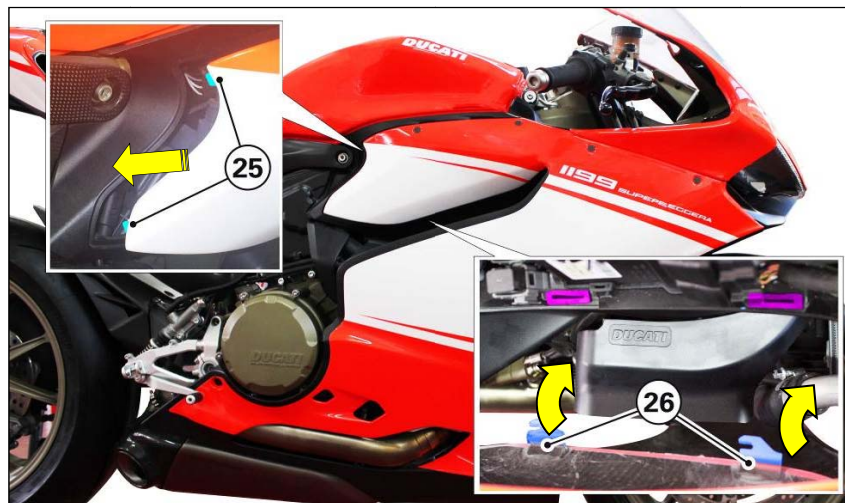



1199 Superleggera Clutch
Models: Model Year 2014 1199 Superleggera (all country versions)
Recall Bulletin SRV-RCL-16-002

- 15) Repeat the same procedure for left side cover and tighten **screw M5x0.8 (33)** to a torque of **2.5 Nm ± 10%**.

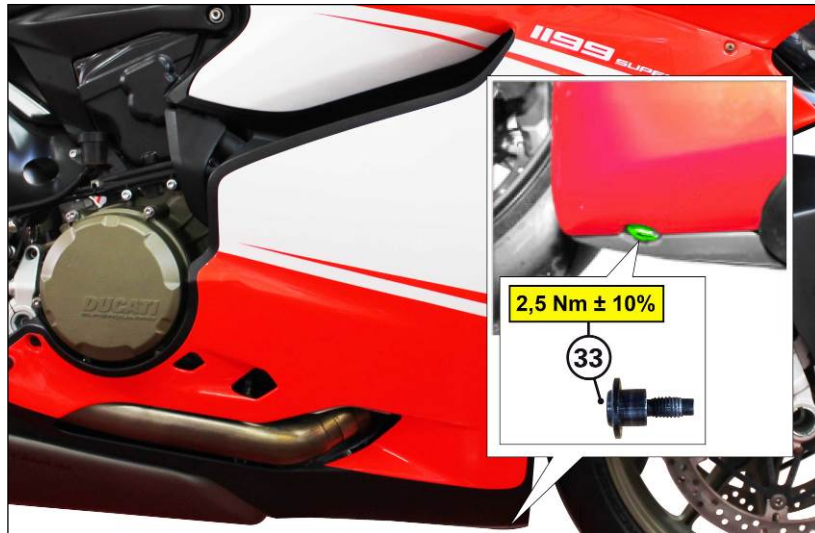

- 16) Fit RH and LH carbon side covers and ignition switch cover (See Section 05 – Fairing – Headlight fairing” of the Workshop Manual).
- 17) Remove rear service stand.

Spare Parts

The part number required for this update is as follows:

<i>Part no.</i>	<i>Description</i>	<i>Quantity</i>
18920344A	Clutch assembly	1
79710711A	Clutch springs	3
85110201A	Safety washer	1
85250541A	Oil drain plug washer	1
44440312B	Oil filter cartridge	1

The engine oil reimbursement required to carry out the replacement procedure is considered through a labor extra-reimbursement of 42 minutes (7 labor units).



1199 Superleggera Clutch
Models: Model Year 2014 1199 Superleggera (all country versions)
Recall Bulletin SRV-RCL-16-002

Warranty time allowance and reimbursement procedure:

Update procedure reimbursement will be issued through the standard warranty claim procedure via the section Recall Campaigns or Vehicle History of the DCS.

The warranty claim is pre-filled, and has been identified as **CR122**. Ducati shall reimburse:

- Labor time of **120 minutes** (20 labor units), also including the time required to:
 - prepare the motorcycle for the operations to be carried out;
 - change engine oil and filter;
 - install the new clutch assembly Part no.87211231A;
 - thoroughly clean the motorcycle;
 - open the work order and fill in the warranty claim;
- An additional labor time of **42 minutes** (7 labor units) to compensate for the engine oil cost;
- All the relevant spare parts required to make the update.

Customers:

Ducati North America, Inc. will notify all known owners of affected vehicles directly by First Class mail. A sample copy of the owner notification letter is enclosed for your information.

Please be reminded that all motorcycles in your inventory, and to be delivered to Customers, must be updated during pre-delivery operations, and ALWAYS before delivery to the final Customer. For retailed units, the update must be performed upon the motorcycles' arrival for service or repairs.

Campaign authorization:

Ducati North America, Inc. will mail a notification letter to all known owners. If a customer does not present this notification letter, it is important that you confirm the eligibility for recall status on the DCS before you commence work. Reimbursement requests for duplicate recall campaign repairs will not be accepted.

Dealer obligation:

This program is designed to complete the necessary repairs and to achieve owner satisfaction. Therefore, we ask you to take prompt and courteous action in accordance with these directives. Please provide a copy of this communication to every person in your dealership who has recall-related responsibilities.

Thank you for your cooperation.

Service Department
Ducati North America, Inc.

Ducati North America
www.ducatiusa.com

10443 Bandle Drive
Cupertino, CA 95014
Tel. +1 408 253 0499
Fax +1 408 253 4099



1199 Superleggera Clutch
Models: Model Year 2014 1199 Superleggera (all country versions)
Recall Bulletin SRV-RCL-16-002

Sample of Customer Letter

IMPORTANT SAFETY RECALL

This notice applies to your vehicle: VIN

Date

Name

Address

City, St, Zip

Subject: ***Ducati Motorcycle:
Model Year 2014 1199 Superleggera***

NHTSA Campaign I.D. Number: 16V370
Transport Canada Safety Recall I.D. Number: 2016-247

Dealer Bulletin: SRV-RCL-16-002

Dear Ducati Owner,

This notice is sent to you in accordance with the National Traffic and Motor Vehicle Safety Act & Canada Motor Vehicle Safety Act.

Ducati Motor Holding S.P.A. has decided that a defect which relates to motor vehicle safety exists in Model Year 2014 1199 Superleggera motorcycles. Our records indicate that you are the owner of a Ducati motorcycle affected by this safety recall campaign. Please take the time to read this letter and help us take the appropriate steps to ensure that your vehicle is operating properly.

What is wrong?

On-going quality testing on the motorcycles as manufactured, as well as analysis of field reports, has identified a potential safety issue affecting all Model Year 2014 1199 Superleggera motorcycles. Ducati has determined that the damper plate assembled between the primary driven gear and the clutch basket assembly may fatigue and break on your motorcycle. If this occurs, part of the assembly could become displaced and could result in engine stalling or rear wheel lockup during use of the bike. Lost propulsion, in conjunction with traffic and road conditions, and the rider's reactions, could increase the risk of a crash causing injury and/or property damage.



1199 Superleggera Clutch
Models: Model Year 2014 1199 Superleggera (all country versions)
Recall Bulletin SRV-RCL-16-002

What will Ducati do?

To correct this condition, your authorized Ducati dealer will replace the clutch assembly with a new redesigned component. In order to make this an amenable experience Ducati will also provide the customer with an engine oil and filter cartridge replacement. The Dealer will perform these two interventions at no cost to you for parts and labor. We request that you contact your authorized Ducati dealer and schedule an appointment, so that the required service can be performed without delay. To locate your nearest authorized Ducati dealer, please go to www.ducati.com, or www.canada.ducati.com, and select the "dealer locator" or you may call toll free from the U.S. 1-800-231-6696. Your dealer can complete the required service in less than three hours, if you have an appointment. If your dealer has a number of vehicles awaiting service, additional time may be required.

Federal regulations require that any lessor receiving this recall notice must forward a copy of this notice to the lessee within ten days.

Service Problem Help:

If you believe that your dealer has failed or is unable to perform the service within a reasonable period of time, please write to:

Ducati North America, Inc.
Attn: Customer Service
10443 Bandle Drive
Cupertino, CA 95014

If you still cannot obtain satisfaction, you may file a complaint with:

For USA Customers:

National Highway Traffic Safety Administration
1200 New Jersey Avenue, SE
Washington, D.C. 20590

Or call toll-free hotline at 1-888-327-4236 (TTY 1- 800-424-9153), or go to [HTTP://WWW.SAFERCAR.GOV](http://WWW.SAFERCAR.GOV).

For Canadian customers:

Please contact Ducati customer service at 1-888-391-5446 or for additional information about the recall you can contact Transport Canada at 1-800-333-0510.



1199 Superleggera Clutch
Models: Model Year 2014 1199 Superleggera (all country versions)
Recall Bulletin SRV-RCL-16-002

TREADACT CUSTOMER REIMBURSEMENT PLAN

If you have paid for the repair described in the attached letter, and you would like to be considered for reimbursement, please contact your authorized Ducati dealer. Expenses from repair facilities outside of the authorized Ducati dealer network will be considered; however, the procedure must meet Ducati North America's standards.

Your authorized Ducati retailer will request a copy of your owner notification letter, as well as, a copy of your previously paid invoice. They inspect the vehicle, if still in your possession, prior to submitting a claim on your behalf to Ducati North America, Inc. for reimbursement.

Please note the following:

Only a repair subject of this safety recall campaign is reimbursable. Ducati North America, Inc will not reimburse consequential expenses such as towing, rental, accommodations, and damage repairs.

We recommend that your authorized Ducati dealer be your primary contact on this issue. We anticipate that your authorized Ducati dealer will be able to answer any questions that you may have regarding your qualifications for reimbursement of a previous repair; however, our Customer Relations Dept. may be contacted at 408-253-0499 for any special assistance required.

We regret any inconvenience to you from this action; however, your safety and satisfaction are important to us. We request that you bring your Ducati motorcycle to your nearest authorized Ducati dealer at your earliest convenience.

Thank you for riding Ducati.

Sincerely,

Ducati North America
Service Department