



Bulletin No.: 20760E
Date: September 2018

Recall Bulletin

PRODUCT SAFETY RECALL

SUBJECT: Brake Pedal Pivot Nut/Bolt Loose

MODELS: 2015 - 2016 Chevrolet Silverado Crew Cab LD with Special Services (RPO 5W4)
2015 - 2016 Chevrolet Silverado HD
2015 - 2016 Chevrolet Tahoe PPV (RPO 9C1)
2015 - 2016 Chevrolet Tahoe with Special Services (RPO 5W4)
2015 - 2016 GMC Sierra HD

This bulletin has been revised to update the warranty and service procedure sections, and to remove the need for inspection in the correction statement. Please discard all copies of bulletin 20760D.

Vehicles involved in this recall were placed on stop delivery February 3, 2016. Once the service procedure contained in this bulletin has been performed on the vehicle, the vehicle is released from stop delivery and the vehicle can be delivered to the customer.

All involved vehicles that are in dealer inventory must be held and not delivered to customers, dealer traded, or used for demonstration purposes until the repair contained in this bulletin has been performed on the vehicle.

It is a violation of Federal law for a dealer to deliver a new motor vehicle or any new or used item of motor vehicle equipment (including a tire) covered by this notification under a sale or lease until the defect or noncompliance is remedied.

CONDITION

General Motors has decided that a defect which relates to motor vehicle safety exists in **certain** 2015-2016 model year Chevrolet Silverado 2500/3500 Heavy Duty Pickup Trucks, GMC Sierra 2500/3500 Heavy Duty Pickup Trucks, Chevrolet Tahoe PPV (RPO 9C1), and Chevrolet Tahoe and Chevrolet Silverado Crew Cab LD Special Services (RPO 5W4) vehicles. The brake pedal pivot nut on these vehicles may become loose, causing the brake pedal to be loose or inoperative. If the brake pedal becomes loose or inoperative, the driver may be unable to safely stop the vehicle through application of the brake pedal, increasing the risk of a crash. A loose pedal may also interfere with the accelerator pedal, increasing the risk of a crash.

CORRECTION

Dealers are to add adhesive to the nut, and reinstall the nut at an increased torque.

VEHICLES INVOLVED

All involved vehicles are identified by Vehicle Identification Number on the Investigate Vehicle History screen in GM Global Warranty Management system. Dealership service personnel should always check this site to confirm vehicle involvement prior to beginning any required inspections and/or repairs. It is important to routinely use this tool to verify eligibility because not all similar vehicles may be involved regardless of description or option content.

For dealers with involved vehicles, a listing with involved vehicles containing the complete vehicle identification number, customer name, and address information has been prepared and will be provided to US and Canadian dealers through the GM GlobalConnect Recall Reports, or sent directly to export dealers. Dealers will not have a report available if they have no involved vehicles currently assigned.

The listing may contain customer names and addresses obtained from Motor Vehicle Registration Records. The use of such motor vehicle registration data for any purpose other than follow-up necessary to complete this recall is a violation of law in several states/provinces/countries. Accordingly, you are urged to limit the use of this report to the follow-up necessary to complete this recall.

PART INFORMATION

Parts required to complete this recall are to be obtained from General Motors Customer Care and Aftersales (GMCC&A). If unable to procure from GMCC&A see one of the other options listed to be obtained locally.

Caution: Do NOT use a bottle of Loctite that is more than a year old.

Part Number	Description	Quantity/Vehicle
19369733 (US)	General Purpose Adhesive (0.34 oz) (Threadlocker – Red)	1 tube fixes approx. 25 vehicles
10953488 (CA)	Anaerobic Sealant (10 mL)	1 tube fixes approx. 25 vehicles
Obtain Locally	Permatex High Strength Threadlocker 27100 (0.20 oz)	1 tube fixes approx. 25 vehicles
Obtain Locally	Loctite Threadlocker Red 271 209741 (6 mL)	1 tube fixes approx. 25 vehicles

SERVICE PROCEDURE

1. Determine if the vehicle is equipped with a manual transmission.
 - If the vehicle is equipped with an automatic transmission, proceed to step 2.
 - If the vehicle is equipped with a manual transmission, remove the clutch pedal. Refer to *Clutch Pedal Replacement* in SI. After the clutch pedal has been removed, proceed to step 4.
2. Remove the Instrument Panel Knee Bolster. Refer to *Instrument Panel Knee Bolster Replacement* in SI.
3. Remove the Front Floor Air Outlet Duct – Left Side. Refer to *Front Floor Air Outlet Duct Replacement – Left Side* in SI.

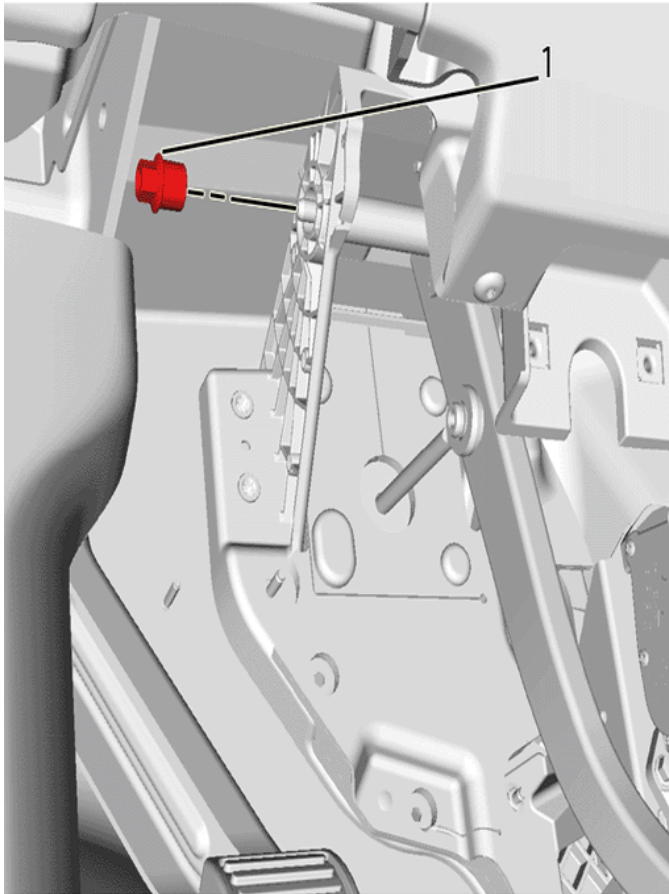

4404322

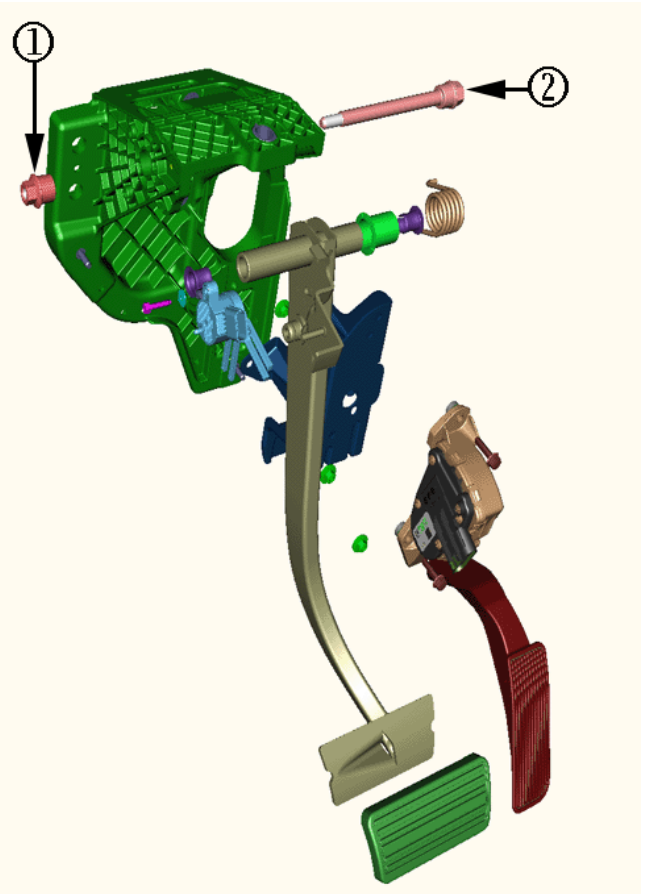

Caution: Apply pressure to the brake pedal pivot bolt while removing the nut to ensure the bolt does not back out of the housing. Part damage could occur if the bolt backs out of the housing.

Note: The bolt may be facing either direction, not necessarily the direction shown above. Do NOT attempt to reorient the bolt and nut if they are not facing the direction shown in the photo – only apply Loctite to the nut and torque to specification as described below.

4. Holding the brake pedal pivot bolt (2) with a box end wrench, remove the brake pedal pivot nut (1).

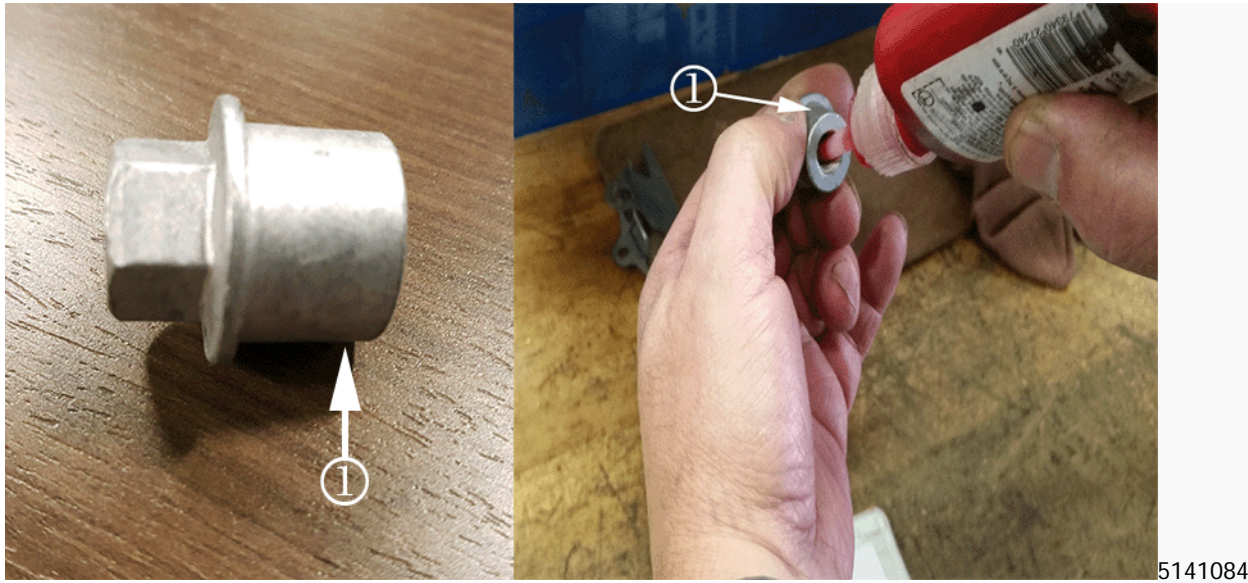

Note: Do NOT get threadlocker on the exterior of the brake pedal pivot nut. The exterior of the brake pedal pivot nut must be kept clean of threadlocker.

- 5. Holding the nut horizontally, apply two drops of red threadlocker to the threads in the collar portion (1, opposite the hex end) of the nut.

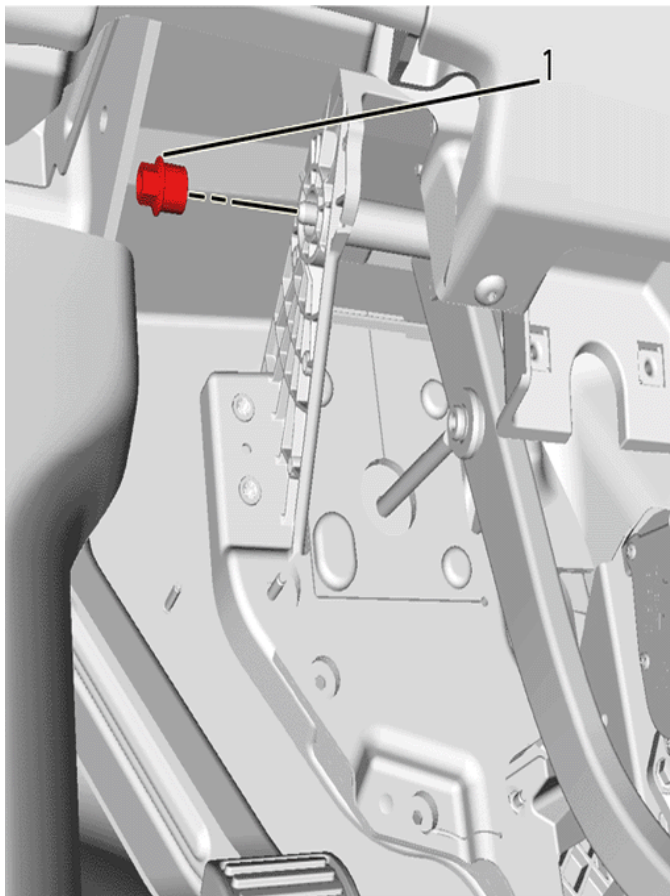

4404322

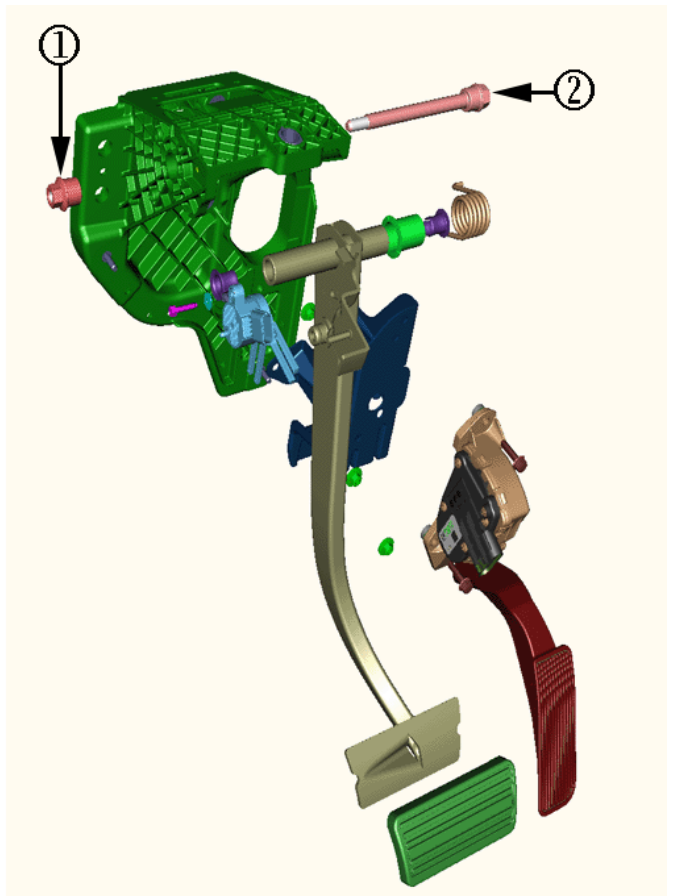

Caution: Apply pressure to the brake pedal pivot bolt while installing the nut to ensure the bolt does not back out of the housing. Part damage could occur if the bolt backs out of the housing.

6. Holding the brake pedal pivot bolt (2) with a box end wrench, install the brake pedal pivot nut (1).
7. Holding the brake pedal pivot bolt with a box end wrench, torque the brake pedal pivot nut to 26 Nm (19 lb ft).
8. On vehicles equipped with a manual transmission, install the clutch pedal, then proceed to step 11. Refer to *Clutch Pedal Replacement* in SI.
9. Install the Floor Front Air Outlet Duct - Left Side. Refer to *Floor Front Air Outlet Duct Replacement - Left Side* in SI.
10. Install the Instrument Panel Knee Bolster. Refer to *Instrument Panel Knee Bolster Replacement* in SI.
11. For all vehicles, perform the brake pedal position sensor relearn procedure. Refer to *Brake Pedal Position Sensor Calibration* in SI.

COURTESY TRANSPORTATION – For US and Canada

The General Motors Courtesy Transportation program is intended to minimize customer inconvenience when a vehicle requires a repair that is covered by the New Vehicle Limited Warranties. The availability of courtesy transportation to customers whose vehicles are within the warranty coverage period and involved in a product program is very important in maintaining customer satisfaction. Dealers are to ensure that these customers understand that shuttle service or some other form of courtesy transportation is available and will be provided at no charge. Dealers should refer to the General Motors Service Policies and Procedures Manual for Courtesy Transportation guidelines.

WARRANTY TRANSACTION INFORMATION

Submit a transaction using the table below. All transactions should be submitted as a ZFAT transaction type, unless noted otherwise.

Labor Code	Description	Labor Time	Net Item
9102038	Apply Threadlocker to Brake Pedal Pivot Nut Add: Clutch Pedal Removal and Installation (Manual Transmission Only)	0.6** 1.7	*

* The amount identified in “Net Item” should represent the actual sum total of the current GMCCA Dealer net price for Threadlocker needed to perform the required repairs, not to exceed \$0.40 USD/CAD.

** The labor time includes applying Threadlocker to the brake pedal pivot nut and performing the brake pedal position sensor calibration.

CUSTOMER NOTIFICATION – For US and Canada

General Motors will notify customers of this recall on their vehicle (see copy of customer letter included with this bulletin).

CUSTOMER NOTIFICATION – For Export

Letters will be sent to known owners of record located within areas covered by the US National Traffic and Motor Vehicle Safety Act. For owners outside these areas, dealers should notify customers using the attached sample letter.

DEALER RECALL RESPONSIBILITY – For US and Export (US States, Territories, and Possessions)

It is a violation of Federal law for a dealer to deliver a new motor vehicle or any new or used item of motor vehicle equipment (including a tire) covered by this notification under a sale or lease until the defect or noncompliance is remedied.

The US National Traffic and Motor Vehicle Safety Act provides that each vehicle that is subject to a recall of this type must be adequately repaired within a reasonable time after the customer has tendered it for repair. A failure to repair within sixty days after tender of a vehicle is prima facie evidence of failure to repair within a reasonable time. If the condition is not adequately repaired within a reasonable time, the customer may be entitled to an identical or reasonably equivalent vehicle at no charge or to a refund of the purchase price less a reasonable allowance for depreciation. To avoid having to provide these burdensome remedies, every effort must be made to promptly schedule an appointment with each customer and to repair their vehicle as soon as possible. In the recall notification letters, customers are told how to contact the US National Highway Traffic Safety Administration if the recall is not completed within a reasonable time.

DEALER RECALL RESPONSIBILITY – All

All new, used, GM Certified Used, courtesy transportation vehicles, dealer shuttle vehicles, etc. in dealers' possession and subject to this recall must be held and inspected/repaired per the service procedure of this bulletin before customers take possession of these vehicles. Involved vehicles must be held and not delivered to customers, dealer-traded, released to auction, used for demonstration, or any other purpose.

All GM Certified Used vehicles currently in the dealers' inventory within the Certified Pre-Owned Inventory System (CPOIS) will be de-certified and must be held and remedied per the service procedure in this bulletin. Upon submitting an accepted/paid warranty transaction in the Global Warranty Management (GWM) system, the vehicle can be re-certified for sale within the CPOIS system, or once again be used in the CTP program.

Dealers are to service all vehicles subject to this recall at no charge to customers, regardless of mileage, age of vehicle, or ownership, from this time forward.

Customers who have recently purchased vehicles sold from your vehicle inventory, and for which there is no customer information indicated on the dealer listing, are to be contacted by the dealer. Arrangements are to be made to make the required correction according to the instructions contained in this bulletin. A copy of the customer letter is provided in this bulletin for your use in contacting customers. Recall follow-up cards should not be used for this purpose, since the customer may not as yet have received the notification letter.

In summary, whenever a vehicle subject to this recall enters your vehicle inventory, or is in your dealership for service in the future, you must take the steps necessary to be sure the recall correction has been made before selling or releasing the vehicle.

GM bulletins are intended for use by professional technicians, NOT a "do-it-yourselfer". They are written to inform these technicians of conditions that may occur on some vehicles, or to provide information that could assist in the proper service of a vehicle. Properly trained technicians have the tools, equipment, safety instructions, and know-how to do a job properly and safely. If a condition is described, **DO NOT** assume that the bulletin applies to your vehicle, or that your vehicle will have that condition. See your dealer for information on whether your vehicle may benefit from the information.



**We Support
Voluntary Technician
Certification**



IMPORTANT SAFETY RECALL

March 2016

This notice applies to your vehicle, **VIN:** _____

Dear General Motors Customer:

This notice is sent to you in accordance with the National Traffic and Motor Vehicle Safety Act.

General Motors has decided that a defect which relates to motor vehicle safety exists in **certain** 2015-2016 model year Chevrolet Silverado 2500/3500 Heavy Duty Pickup Trucks, GMC Sierra 2500/3500 Heavy Duty Pickup Trucks, Chevrolet Tahoe PPV (RPO 9C1), and Chevrolet Tahoe and Chevrolet Silverado Crew Cab LD Special Services (RPO 5W4) vehicles. As a result, GM is conducting a safety recall. We apologize for this inconvenience. However, we are concerned about your safety and continued satisfaction with our products.

IMPORTANT

- Your vehicle is involved in GM recall 20760.
- Schedule an appointment with your GM dealer.
- This service will be performed for you at **no charge**.

Why is your vehicle being recalled?

The brake pedal pivot nut on your vehicle may become loose, causing the brake pedal to be loose or inoperative. If the brake pedal becomes loose or inoperative, the driver may be unable to safely stop the vehicle through application of the brake pedal, increasing the risk of a crash. A loose pedal may also interfere with the accelerator pedal, increasing the risk of a crash.

What will we do?

Your GM dealer will inspect the pivot bolt installation to determine whether your vehicle has already received the production remedy. If not, your dealer will add adhesive to the nut, and reinstall the nut at an increased torque. This service will be performed for you at **no charge**. Because of service scheduling requirements, it is likely that your dealer will need your vehicle longer than the actual inspection and service correction time of approximately 40 minutes.

What should you do?

You should contact your GM dealer to arrange a service appointment as soon as possible.

Do you have questions?

If you have questions or concerns that your dealer is unable to resolve, please contact the appropriate Customer Assistance Center at the number listed below.

Division	Number	Text Telephones (TTY)
Chevrolet	1-800-630-2438	1-800-833-2438
GMC	1-866-996-9463	1-800-462-8583
Puerto Rico – English	1-800-496-9992	
Puerto Rico – Español	1-800-496-9993	
Virgin Islands	1-800-496-9994	

If after contacting your dealer and the Customer Assistance Center, you are still not satisfied we have done our best to remedy this condition without charge and within a reasonable time, you may wish to write the Administrator, National Highway Traffic Safety Administration, 1200 New Jersey Avenue, SE, Washington, DC 20590, or call the toll-free Vehicle Safety Hotline at 1.888.327.4236 (TTY 1.800.424.9153), or go to <http://www.safercar.gov>. The National Highway Traffic Safety Administration Campaign ID Number for this recall is 16V069.

Federal regulation requires that any vehicle lessor receiving this recall notice must forward a copy of this notice to the lessee within ten days.

Jeffrey M. Boyer
Vice President
Global Vehicle Safety

GM Recall 20760