

# Product Safety Recall

## 15043 Driver Air Bag Replacement



Reference Number: N162028811

Release Date: August 2017  
Revision: 00

**Attention:** At the request of the National Highway Transportation Safety Administration (NHTSA), General Motors has agreed to help facilitate the repair of the Saab vehicles involved in this safety recall at Cadillac dealerships. This action is part of ongoing efforts to increase the replacement rate of potentially defective Takata air bag inflators.

Involved are all 2006-2011 model year Saab 9-3 and 2006-2009 model year Saab 9-5 vehicles currently registered or previously registered in Alabama, California, Florida, Georgia, Hawaii, Louisiana, Mississippi, South Carolina, Texas, Guam, Puerto Rico, Saipan, U.S. Samoa or U.S. Virgin Islands.

It is a violation of Federal law for a dealer to deliver a new motor vehicle or any new or used item of motor vehicle equipment (including a tire) covered by this notification under a sale or lease until the defect or noncompliance is remedied.

Make	Model	Model Year		RPO	Description
		From	To		
Saab	9-3	2006	2011		
Saab	9-5	2006	2009		

Involved vehicles are marked "open" on the Investigate Vehicle History screen in GM Global Warranty Management system. This site should always be checked to confirm vehicle involvement prior to beginning any required inspections and/or repairs.

<b>Condition</b>	It has been determined that a defect, which relates to motor vehicle safety, exists in all 2006-2011 model year Saab 9-3 and 2006-2009 model year Saab 9-5 vehicles currently registered or previously registered in Alabama, California, Florida, Georgia, Hawaii, Louisiana, Mississippi, South Carolina, Texas, Guam, Puerto Rico, Saipan, U.S. Samoa or U.S. Virgin Islands. In some vehicles, the driver air bag inflator may experience an alteration over time, which could lead to overaggressive combustion in the event of an airbag deployment. This condition could create excessive internal pressure when the air bag is deployed, which could result in the body of the inflator rupturing upon deployment. In the event of an inflator rupture, metal fragments could pass through the air bag cushion material, which may result in injury or death to vehicle occupants.
<b>Correction</b>	Cadillac dealers will replace the driver air bag module assembly.

### Parts

The parts required to complete this recall are to be obtained from General Motors Customer Care and Aftersales (GMCCA) through the normal parts ordering process. **Parts should only be ordered as a Customer Special Order (CSO).** Daily Replenishment Orders (DRO's) will be automatically cancelled. Dealers should not place orders through the Service Parts Assistance Center (SPAC); doing so will delay shipment of the part and will not provide visibility in the order tracking system. **Parts may have quantity limiters in effect and all orders will be reviewed prior to being filled.**

**Important:** Due to flight restrictions for hazardous goods shipments, dealer orders may arrive via FedEx or with the normal Parts Distribution Center (PDC) delivery. Parts will not be shipped overnight and dealers should plan accordingly for possible extended transit time. Also, parts may be removed from Retail Inventory Management (RIM) management. Dealers should review the affected parts to confirm RIM managed status.

Quantity	Part Name	Saab Part No.
1	Module Assembly, Air Bag	39095647

**Note:** Do not discard or destroy the box containing the new air bag module assembly, it will be needed to return the used air bag module assembly. The box contains special instructions for the packaging and shipment of the used air bag module assembly. The instructions must be followed without exception. **DO NOT DEPLOY ANY AIR BAG MODULE.**

### Part Return Procedures – U.S. (48 Contiguous States) and Canada

Each removed air bag module assembly must be returned directly to the supplier - Takata USA.

Refer to the return instructions included in the box with the new air bag module assembly.

- The shipping box contains a bar code label, which will be used by Takata USA to document the replacement of the old air bag module assembly with the new air bag module assembly. **Therefore, it is very important that the removed air bag module assembly be returned in the exact same box that contained the newly-**

# Product Safety Recall

## 15043 Driver Air Bag Replacement



**installed air bag module assembly for that vehicle.** If the original box cannot be re-used, please refer to the shipping instructions under “Requesting a new box/shipping labels.”

- **When sealing and affixing the shipping label to the shipping box, do not obstruct the bar code.** A copy of the job card must be included with the returned air bag module. Please make sure the job card contains the warranty transaction number, the repair date, the full 17-character Vehicle Identification Number (VIN) and mileage.

Dealers located in Alaska, Hawaii or U.S. territories should disregard the return instructions in the box and contact Takata USA directly for special return instructions. Their representative can be reached by telephone at 210-250-5079 or E-Mail at [Takata.InflatorCampaign@menloworldwide.com](mailto:Takata.InflatorCampaign@menloworldwide.com).

### Warranty Information

Labor Operation	Description	Labor Time	Trans. Type
9103357	Replace Driver's Air Bag Module Assembly - Saab 9-3	0.5	ZFAT
9103358	Replace Driver's Air Bag Module Assembly - Saab 9-5	0.7	ZFAT

### General Safety Rules

The following points must be followed without fail when working on the air bag system:

- Work on the air bag system must only be carried out by an authorized service workshop.
- All work must be carried out with the utmost care and as described in the relevant instructions. There is always a danger of injury if the work is not done in the prescribed manner.
- The ignition must always be in the LOCK position when replacing components.
- The battery must be disconnected. Remove the ground cable before removing the positive cable. After disconnecting the battery, wait at least 1 minute before starting work on the airbag system.
- Cables must not be repaired but replaced in full. Cable shoes may not be replaced.
- Components forming part of the system must not be dismantled or repaired. Handle them with care and keep them in a dry place at room temperature.
- Air bags must be stored at room temperature. At temperatures above +115°C there is a danger of self-detonation.
- Air bags must be stored in a special area, away from storage areas for petroleum products or other inflammable materials.
- Air bags must be stored with the rear facing downwards to avoid injury in the event of accidental triggering.
- Place the air bag in a sealed plastic bag. Wash your hands in lukewarm mild soapy water after handling a deployed air bag.
- The seat-belt tensioner must never be exposed to temperatures above +100°C.
- Activation units for the roll bar must be stored at room temperature. At temperatures above +100°C there is a danger of self-detonation.
- Air bags, belt tensioners and roll bar activation units are classed as pyrotechnic items and must be stored and handled in accordance with the laws and regulations of the country concerned.
- Air bags, belt tensioners and roll bar activation units are mounted directly after their extraction from stores. If a break occurs in the work, the air bag, belt tensioner or roll bar activation unit must be returned. Under no circumstances may an air bag, belt tensioner or roll bar activation unit be stored without supervision.
- Belt tensioners, air bags and roll bar activation units which have been dropped onto a hard floor should be replaced. Dropped or damaged components must not be fitted.
- Do not subject the air bag components to electricity or strong electrical fields.
- Never place anything that could act as a projectile on or in front of the air bag component in the event of the airbag self-detonating.
- Flush the eyes immediately with water in case of eye contact with by-products from a detonated airbag.

# Product Safety Recall

## 15043 Driver Air Bag Replacement



**Important:** Whenever beginning to remove (or install) the air bag assembly, and periodically while performing the procedure or after stepping away, remove any possible static charge from your body by momentarily touching a clean, bare metal ground point on the vehicle (e.g. the door striker). Remove from your person all electronic devices including cellphones before proceeding.

### Service Procedure

**Warning:** The battery's ground cable must be removed before the positive cable. Wait for at least 1 minute after disconnecting the battery before beginning any work on the air bag system. Otherwise the airbag may be deployed unintentionally and this can cause fatal/severe personal injuries.

### Saab 9-3 Air Bag Removal

1. Connect the Tech2 diagnostic tool to the data link connector under the dashboard. Check for any diagnostic trouble codes. Diagnostics/Model Year/Saab 9-3 Sport 9440/All/Diagnostic Trouble Codes/Vehicle Check and Read DTC's. If no codes are present in the air bag system continue with this repair. If any diagnostic trouble codes (DTCs) have been set. Record set DTCs, if present, on the Repair Order.

Turn the ignition switch to the position LOCK/OFF and let the key remain in the switch.

2. Loosen the steering wheel adjustment and pull the steering wheel as far back as possible.
3. Turn the steering wheel 45° in one direction from the straight on position.

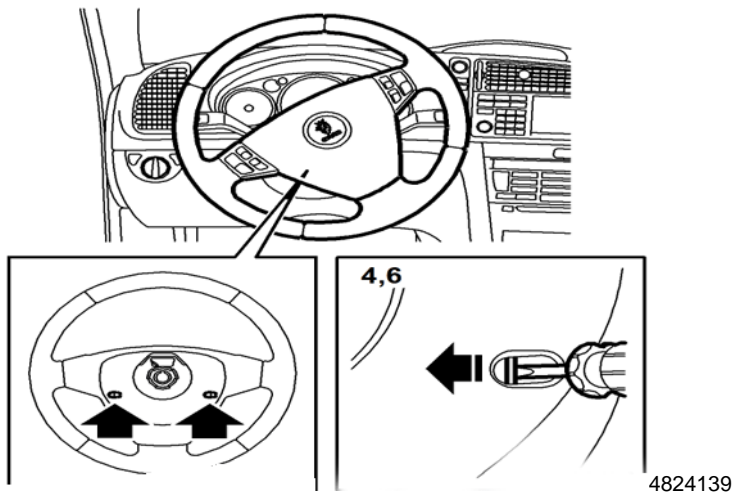

4. Bend away the spring clip with a screwdriver in the hole on the back of the steering wheel.
5. Turn the steering wheel 45° past the straight on position in the other direction.
6. Bend away the spring clip with a screwdriver in the hole on the back of the steering wheel.

**Important:** Exercise the greatest caution when the air bag is removed. There is a significant risk that the connector in the steering shaft control module will be broken.

# Product Safety Recall

## 15043 Driver Air Bag Replacement

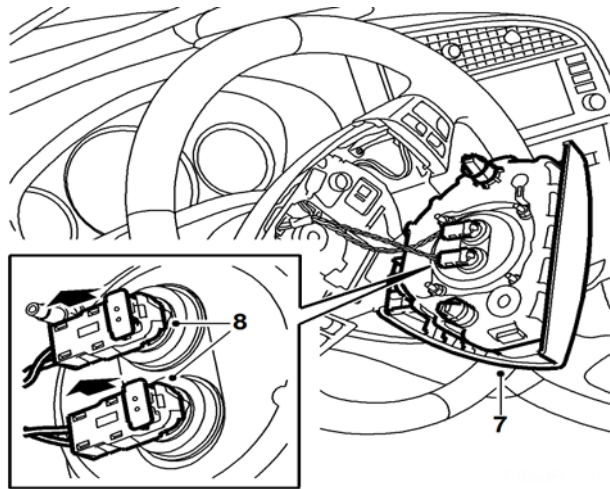

4824141

7. Carefully pull the air bag away from the steering wheel (7).

**Important:** Take care when releasing the locking mechanism on the connector so as not to damage the connector. Pull the halves straight apart to avoid bending the pins.

8. Pull up the connector catches using a small screwdriver. Remove the connector (8).

### Saab 9-3 Air Bag Installation

**Important:** Take care when plugging in the connector so as not to damage or press out the pins/sleeves in the connector.

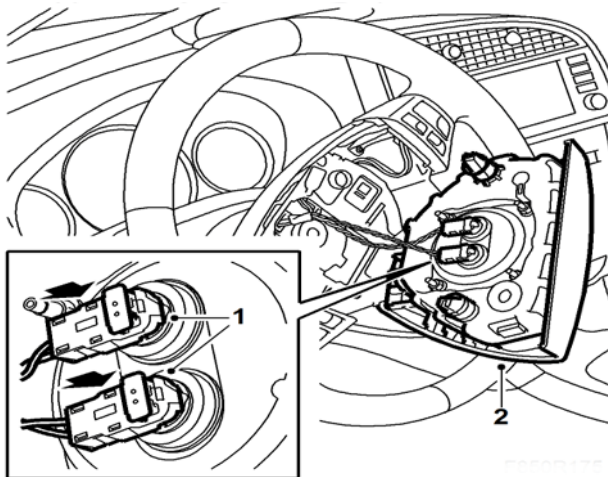

4824146

1. Fit the connector and press in the catches (1).
2. Fit the airbag into the steering wheel (2).
3. Connect the battery.
4. Turn ON the ignition switch and wait one minute. Check the air bag system and control module for DTC's using the Tech2 diagnostic tool as follows:
  - Connect the Tech2 diagnostic tool to the data link connector under the dashboard. Diagnostics/Model Year/Saab 9-3 Sport 9440/All/Diagnostic Trouble Codes/Vehicle Check and Read DTC's.

Check whether a diagnostic trouble code (DTC) is displayed:

# Product Safety Recall

## 15043 Driver Air Bag Replacement



- If a diagnostic trouble code is shown, carry out fault diagnosis according to the instructions under respective trouble codes.
  - If no diagnostic trouble code is shown, the assembly was successful. Disconnect the diagnostic tool.
5. Carry out Measures after disconnecting the battery.

### Measures After Disconnecting the Battery

1. Clear diagnostic trouble codes in all systems.
2. Set the clock in the Radio.
3. Set the date (if applicable).

**Important:** All remote controls not present with the vehicle must be synchronized by placing the key/keys in the ignition lock. Until this is done, the remote control will not work.

4. Synchronize the remote control's code by inserting the key in the ignition switch.

**Warning:** The pinch protection is not active until the window lifts have been calibrated after a battery disconnection.

5. **Cars with pinch protection:** Program the pinch protection.

### Calibration of Pinch Protection

The end positions and travel must be calibrated following mechanical work affecting the end position of the window, the replacement of the motor or door control module, or a loss of power such as when the battery is changed. Calibration must be carried out after all work involving removal of the door trim. Before the end positions have been calibrated, express closing will be disabled, which also means that the comfort closing and pinch protection functions will be inoperative.

**Note:** Only one control module may be calibrated at a time owing to voltage variations.

1. Shut the doors.
2. Start the car.
3. Open the window about 15 cm (6 in).
4. Close the window completely and hold the button for at least 1 second after the window stops.
5. Press down the button and the window will now go down by itself.
6. Wait at least 1 second.
7. Drive the window fully up and hold the button in position until closing confirmed with a sound signal (beep).

**Note:** If this action does not work use the pinch protection calibration found in the Tech2 under path: Diagnostics/Model Year/Saab 9-3 Sport/All/Service/Learn Anti-Pinch. Then follow the prompts.

### Saab 9-5 Air Bag Removal

1. Connect the Tech2 diagnostic tool to the data link connector under the dashboard. Check for any diagnostic trouble codes. Diagnostics/Model Year/Saab 9-5/Body/Air Bag/Check and Read DTC's. If no codes are present in the air bag system continue with this repair. If any diagnostic trouble codes (DTCs) have been set. Record set DTCs, if present, on the job card.

Turn the ignition switch to the position LOCK/OFF and let the key remain in the switch.

2. Loosen the steering wheel adjustment and pull the steering wheel as far back as possible.

# Product Safety Recall

## 15043 Driver Air Bag Replacement



3. Turn the steering wheel 45° in one direction from the straight on position.

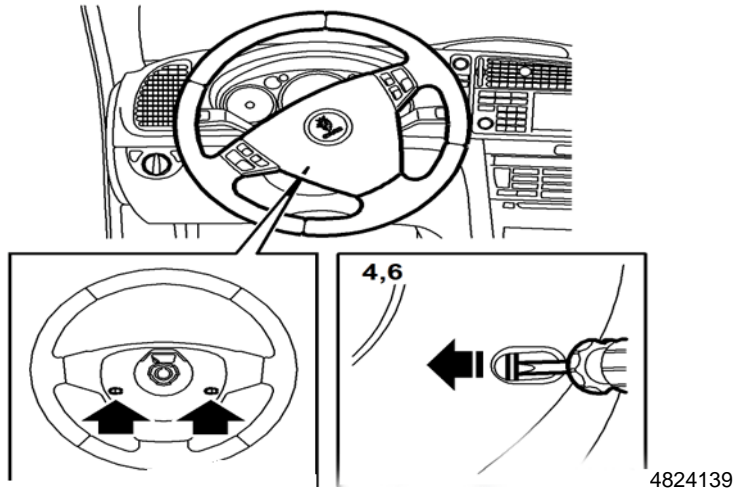

4. Bend away the spring clip with a screwdriver in the hole on the back of the steering wheel.
5. Turn the steering wheel 45° past the straight on position in the other direction.
6. Bend away the spring clip with a screwdriver in the hole on the back of the steering wheel.

**Important:** Be extremely careful when removing the air bag. There is a considerable risk of breaking the connector in the contact roller.

**Note:** Exercise caution with the wiring harness when the air bag is removed from the steering wheel.

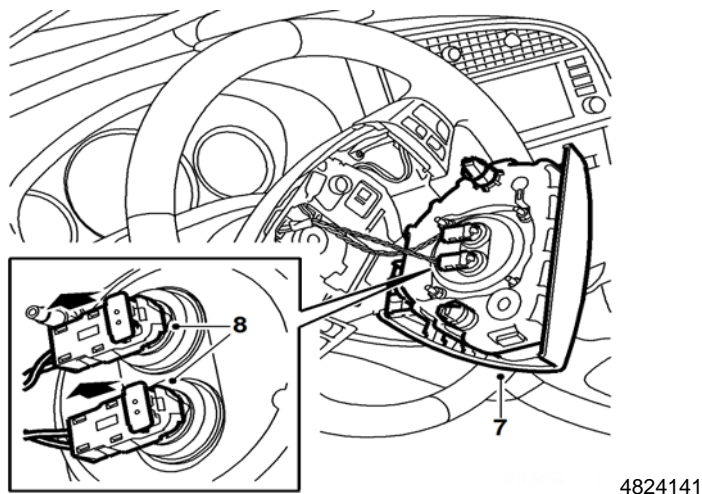

7. Carefully pull the air bag away from the steering wheel (7).

**Important:** Take care when releasing the locking mechanism on the connector so as not to damage the connector. Pull the halves straight apart to avoid bending the pins.

8. Pull up the connector's locking catches using a small screwdriver. Unplug the connectors (8).

# Product Safety Recall

## 15043 Driver Air Bag Replacement



### Saab 9-5 Air Bag Installation

Important: Take care when plugging in the connector so as not to damage or press out the pins/sleeves in the connector.

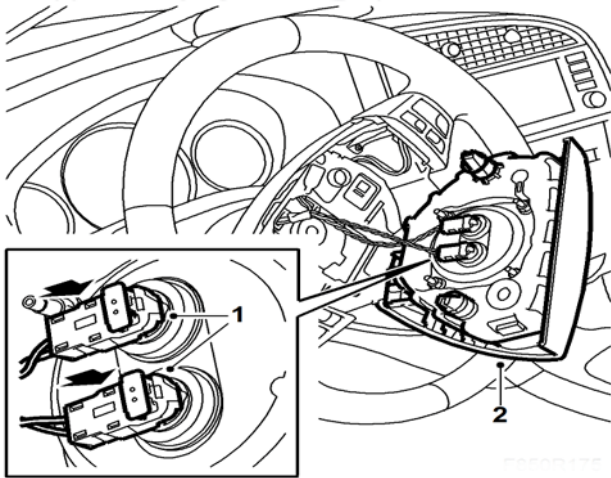

4824146

6. Plug in the connectors and press in the locking catches (1).
7. Fit the airbag into the steering wheel (2).
8. Connect the battery.
9. Switch on the ignition and check the air bag system and control module as follows:
  - Connect the Tech2 diagnostic tool to the diagnostic socket under the dashboard. Diagnostics/Model Year/Saab 9-5/Body/Air Bag/Check and Read DTC's.  
Check whether a diagnostic trouble code (DTC) is displayed:
  - If a diagnostic trouble code is shown carry out fault diagnosis in accordance with the directions given for each DTC.
  - If no diagnostic trouble code is shown disconnect the diagnostic tool.
10. Carry out Measures after disconnecting the battery.

Measures after disconnecting the Battery Saab 9-5

6. Set the time and date in radio.
7. Carry out Manual calibration, ACC:
  - 7.1. Start the engine.

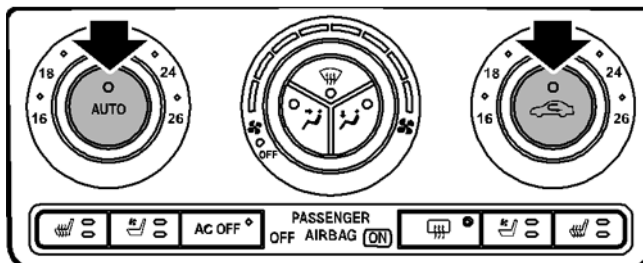

4824148

# Product Safety Recall

## 15043 Driver Air Bag Replacement



7.2. Press in the AUTO and REC buttons until the message "ACC: CALIBR. STARTED" is shown on the main instrument unit display. Calibration takes approximately 20 seconds.

### Dealer Responsibility – For USA & Export (USA States, Territories, and Possessions)

It is a violation of Federal law for a dealer to deliver a new motor vehicle or any new or used item of motor vehicle equipment (including a tire) covered by this notification under a sale or lease until the defect or noncompliance is remedied.

The U.S. National Traffic and Motor Vehicle Safety Act provides that each vehicle that is subject to a recall of this type must be adequately repaired within a reasonable time after the customer has tendered it for repair. A failure to repair within sixty days after tender of a vehicle is prima facie evidence of failure to repair within a reasonable time. If the condition is not adequately repaired within a reasonable time, the customer may be entitled to an identical or reasonably equivalent vehicle at no charge or to a refund of the purchase price less a reasonable allowance for depreciation. To avoid having to provide these burdensome remedies, every effort must be made to promptly schedule an appointment with each customer and to repair their vehicle as soon as possible. In the recall notification letters, customers are told how to contact the U.S. National Highway Traffic Safety Administration if the recall is not completed within a reasonable time.

### Dealer Responsibility – All

All new, used, GM Certified Used, courtesy transportation vehicles, dealer shuttle vehicles, etc. in dealers' possession and subject to this recall must be held and inspected/repaired per the service procedure of this bulletin before customers take possession of these vehicles. Involved vehicles must be held and not delivered to customers, dealer-traded, released to auction, used for demonstration, or any other purpose.

All GM Certified Used vehicles currently in the dealers' inventory within the Certified Pre-Owned Inventory System (CPOIS) will be de-certified and must be held and remedied per the service procedure in this bulletin. Upon submitting an accepted/paid warranty transaction in the Global Warranty Management (GWM) system, the vehicle can be re-certified for sale within the CPOIS system, or once again be used in the CTP program.

Dealers are to service all vehicles subject to this recall at no charge to customers, regardless of mileage, age of vehicle, or ownership, from this time forward.

Customers who have recently purchased vehicles sold from your vehicle inventory, and for which there is no customer information indicated on the dealer listing, are to be contacted by the dealer. Arrangements are to be made to make the required correction according to the instructions contained in this bulletin. A copy of the customer letter is provided in this bulletin for your use in contacting customers. Recall follow-up cards should not be used for this purpose, since the customer may not as yet have received the notification letter.

In summary, whenever a vehicle subject to this recall enters your vehicle inventory, or is in your dealership for service in the future, you must take the steps necessary to be sure the recall correction has been made before selling or releasing the vehicle.

### Dealer Reports

For dealers with involved vehicles, a listing with involved vehicles has been prepared and will be provided to U.S. and Canadian dealers through the GM GlobalConnect Recall Reports, or sent directly to export dealers. The listing may contain customer names and addresses obtained from Motor Vehicle Registration Records. The use of such motor vehicle registration data for any purpose other than follow-up necessary to complete this recall is a violation of law in several states/provinces/countries. Accordingly, you are urged to limit the use of this report to the follow-up necessary to complete this recall.

### Customer Notification

USA & Canada - General Motors will notify customers of this recall on their vehicle (see copy of customer letter included with this bulletin).

Export - Letters will be sent to known owners of record located within areas covered by the U.S. National Traffic and Motor Vehicle Safety Act. For owners outside these areas, dealers should notify customers using the attached sample letter.

GM bulletins are intended for use by professional technicians, NOT a "do-it-yourselfer". They are written to inform these technicians of conditions that may occur on some vehicles, or to provide information that could assist in the proper service of a vehicle. Properly trained technicians have the tools, equipment, safety instructions, and know-how to do a job properly and safely. If a condition is described, **DO NOT** assume that the bulletin applies to your vehicle, or that your vehicle will have that condition. See your dealer for information on whether your vehicle may benefit from the information.



**We Support  
Voluntary Technician  
Certification**



# Product Safety Recall

## 15043 Driver Air Bag Replacement



August 2017

This notice applies to your vehicle, VIN: \_\_\_\_\_

Dear Saab Customer:

You were previously notified that your 2006-2011 model year Saab 9-3 or 2006-2009 model year Saab 9-5 vehicle is involved in Saab/GM safety recall 15041. Our records indicate that you have not brought your vehicle in to receive the recall repair. It is important that you receive the recall repair as soon as possible. If you have in fact already brought your vehicle in to receive the recall repair, you may disregard this letter.

**For your convenience, you may now have this important safety recall repair performed at your local Cadillac dealership.** Cadillac dealers now have the necessary training, tools, and parts to properly address this recall on your Saab vehicle. If you prefer, you may still have this recall repair done at your Saab Official Service Center.

### **I M P O R T A N T**

- Your vehicle is involved in Saab/GM safety recall 15041.
- Schedule an appointment with your local Cadillac dealer or Saab Official Service Center as soon as possible.
- This service will be performed for you at **no charge**.

**Why is your vehicle being recalled?** In some vehicles, the driver airbag inflator may experience an alteration over time, which could lead to overaggressive combustion in the event of an air bag deployment. This condition could create excessive internal pressure when the air bag is deployed, which could result in the body of the inflator rupturing upon deployment. In the event of an inflator rupture, metal fragments could pass through the air bag cushion material, which may result in injury or death to vehicle occupants.

**What we will do:** Your local Saab Official Service Center or Cadillac dealer will replace the driver's air bag module assembly on your vehicle. This service will be performed for you at no charge. Because of service scheduling requirements, it is likely that the Saab Official Service Center or Cadillac dealer will need your vehicle longer than the actual service correction time of approximately 45 minutes.

**What you should do:** You should contact your local Saab Official Service Center or Cadillac dealer to arrange a service appointment as soon as possible.

If you have questions or concerns that your local Saab Official Service Center or Cadillac dealer is unable to resolve, please contact the relevant call center: Saab Customer Assistance Center at 1-800-955-9007 or Cadillac Customer Assistance Center at 1-866-982-2339 or, for Text Telephones (TTY), please call 1-800-833-2622.

If after contacting your local Saab Official Service Center or Cadillac dealer and the relevant call center, you are still not satisfied we have done our best to remedy this condition without charge and within a reasonable time, you may wish to write the Administrator, National Highway Traffic Safety Administration, 1200 New Jersey Avenue, SE, Washington, DC 20590, or call the toll-free Vehicle Safety Hotline at 1-888-327-4236 (TTY 1-800-424-9153), or go to <http://www.safercar.gov>. The National Highway Traffic Safety Administration Campaign ID Number for this recall is 16V063.

Federal regulation requires that any vehicle lessor receiving this recall notice must forward a copy of this notice to the lessee within ten days.

Jeffrey M. Boyer  
Vice President  
Global Vehicle Safety

Saab/GM Recall Number: 15043