



**STRICK TRAILERS, LLC**

225 Lincoln Highway  
Fairless Hills  
Pennsylvania, USA  
19030.0009  
215.949.3600



**IMPORTANT SAFETY RECALL**

**This notice applies to your vehicles identified on the enclosed spreadsheet**  
**NHTSA Recall No. 16V-212**

March 28, 2017

CERTIFIED MAIL – R.R.R.

Dear \_\_\_\_\_

This notice is sent in accordance with the requirements of the National Traffic and Motor Vehicle Safety Act and is a follow-up to the previous notice dated June 2, 2016.

Strick Trailers, LLC (“Strick Trailers”) has decided that certain dry freight van trailers, model number S4280E99NFOWW, identified on the enclosed spreadsheet, fail to conform to Federal Motor Vehicle Safety Standard No. 223 “Rear Impact Guards”.

The noncompliance is in regards to the curbside and roadside rear impact guard gussets. Strick Trailers identifies the gussets with the numbers 52236 and 52237. These gussets do not meet the requirements of Federal Motor Vehicle Safety Standard 223 pertaining to rear impact guards. This could increase the risk of injury in the event of a rear impact crash.

In order to remedy the noncompliance, it will be necessary to reinforce the curbside and roadside rear impact guard gussets in accordance with the instructions (Drawing 706545) attached to this letter. We will supply the new reinforcement parts without cost and will ship them to multiple locations at your request. We will also reimburse you for the reasonable direct labor costs involved in effecting the repair or will have the repair facilities bill us directly. The work to reinforce the rear impact guard gussets will take approximately two and one half hours to perform.

We will make ourselves available to answer any questions that arise during the course of this modification program, and, if requested, assist you in locating qualified repair facilities. We will also

provide training or any other support you need. If you need any assistance, please contact me, Kevin Seitz at [kseitz@stricktrailers.com](mailto:kseitz@stricktrailers.com) or 1-260-692-1332.

Invoices for completed work should be submitted with authorization number L2016003 and a list of vehicle identified numbers for the serviced equipment to:

Strick Trailers, LLC  
301 N. Polk Street  
Monroe, IN 46772

If you have had your vehicle repaired prior to receipt of this notice, you may be entitled to reimbursement if you incurred any out-of-pocket cost due to this matter. For further information, please contact us at 1-260-692-1332.

Federal law requires any lessor who receives a notification of a determination of a safety-related defect or noncompliance pertaining to any leased motor vehicle to send the notice to the lessee within 10 days.

We regret any inconvenience this action may cause you. However, we are concerned about your safety, and we have notified the National Highway Traffic Safety Administration of this program. If you are unable to have these defects remedied without charge, you may submit a complaint to:

Administrator, U.S. Department of Transportation  
National Highway Traffic Safety Administration  
Office of Defects Investigation  
1200 New Jersey Avenue, SE  
Washington, D.C. 20590

Alternatively, you may call the toll-free Vehicle Safety Hotline at 1-888-327-4236 (TTY: 1-800-424-9153) or go to <http://www.safercar.gov>.

Thank you for your attention to this important matter.

Sincerely,

A handwritten signature in blue ink that reads "Kevin Seitz" followed by a stylized mark that appears to be a circled "K" or similar initials.

Kevin Seitz  
Warranty Coordinator



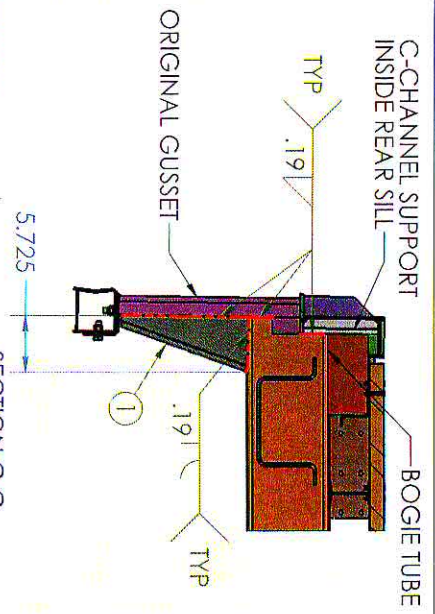
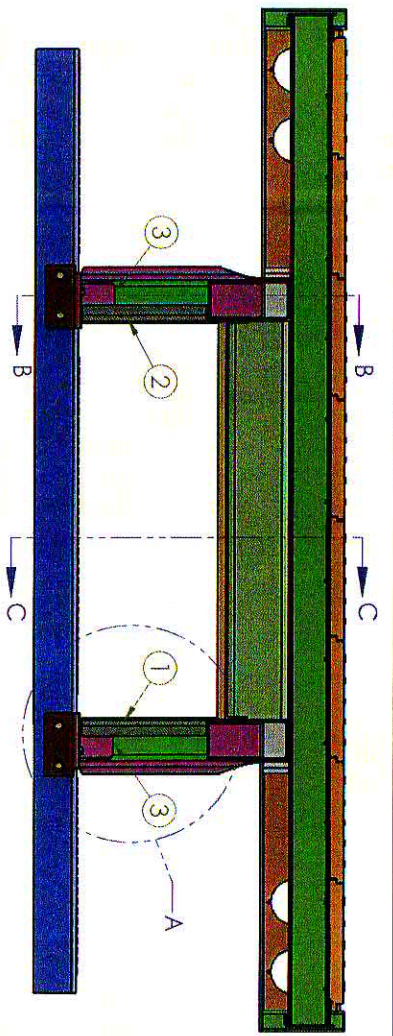

SECTION C-C  
SCALE 1 : 12

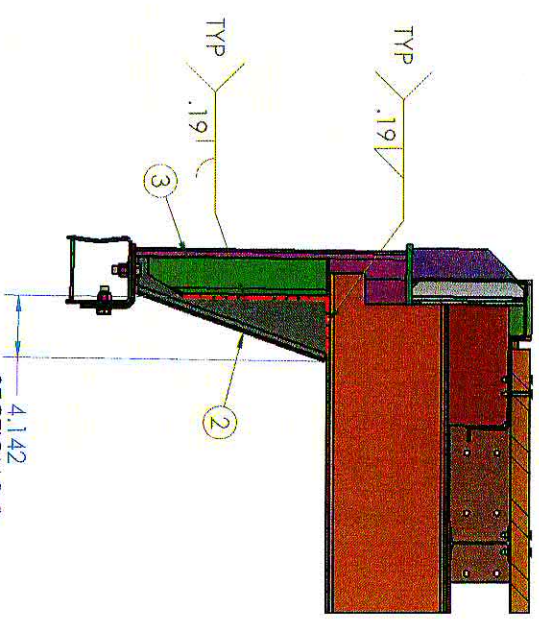
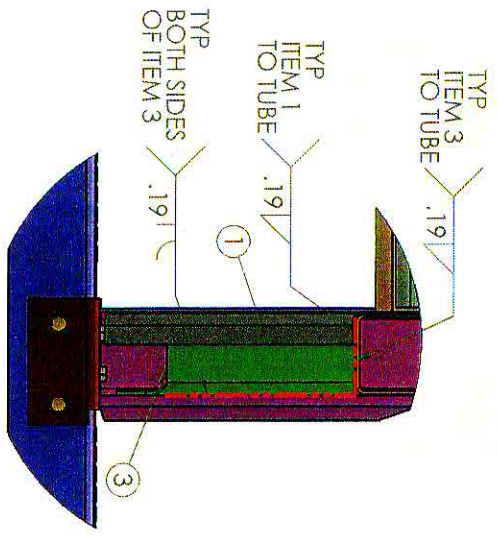

SECTION B-B  
SCALE 1 : 8

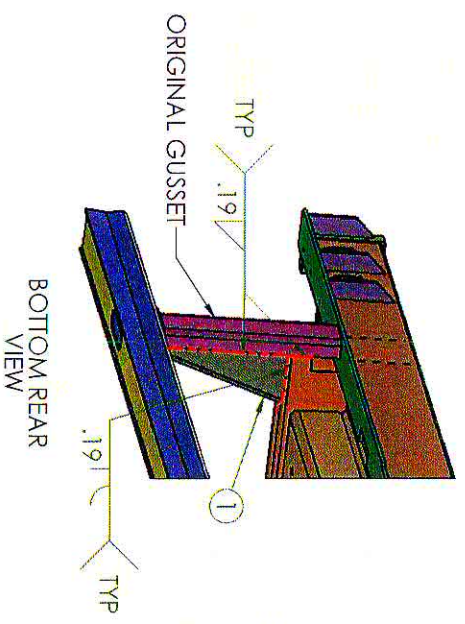

BOTTOM REAR  
VIEW

DETAIL A  
SCALE 1 : 6

ITEM NO.	QTY.	PART NUMBER	Description
1	1	706465	BMPR,GUS.FIX.REINF.RS,52236,SN6.BD,7GA
2	1	706466	BMPR,GUS.FIX.REINF.CS,52236,SN6.BD,7GA
3	2	706472	BMPR,GUS.FIX INNER CHAN,52236,1/4 MAT

706545	JMK	JMK	04/05/2016
DESIGNED BY	CHECKED	DATE	
FABRICATED PARTS	DATE		
ASSEMBLY'S	DATE		
ANGULAR ±1°			

MATERIAL: X		STRICK	STRICK TRAILERS, LLC	MONROE IN 46172	SW
FIELD INST. RIG. ESTES, 52236/37 FIX. 0068		GUSSETS 52236/52237			
PART NUMBER		706545			
SHEET NUMBER		Sheet 2 of 2			

THIS DRAWING IS LOANED FOR PURPOSE OF ENGINEERING STUDY ONLY WITH THE UNDERSTANDING THAT IT SHALL BE HELD IN CONFIDENCE AND FOR THE PURPOSES OF STRICK TRAILERS, LLC. IT IS TO BE USED ONLY FOR THE PROJECT AND SPECIFICALLY IDENTIFIED IN THIS DRAWING. IT IS TO BE DESTROYED OR RECYCLED OR DISPOSED OF DIRECTLY OR INDIRECTLY AND NOT TO BE USED IN ANY MANNER FOR MARKING OR DRAWINGS PRINTS APPARATUS OR INFORMATION FOR MARKING OR DRAWINGS PRINTS APPARATUS IN ACCORDANCE WITH THE EXPRESS WRITTEN CONSENT OF STRICK TRAILERS, LLC.