



RECALL CAMPAIGN 16V-914: AUTOLIV AIR BAG

Please perform the procedure outlined in this Service Information on all affected vehicles before customer delivery. In the event the customer has already taken delivery of the vehicle, please perform the procedure the next time the vehicle is in the shop.

This Service Information bulletin replaces SI B72 02 16 **dated December 2016**

MODEL

I01 (i3)	I01 (i3 REx)	I12 (i8)	
----------	--------------	----------	--



SITUATION

BMW AG is conducting a Voluntary Safety Recall involving certain Model Year 2017 vehicles. This involves certain knee air bags (driver and/or passenger) from supplier Autoliv. The specific air bag affected is dependent upon vehicle model and specific VIN.

BMW is committed to helping you manage this recall campaign in the least disruptive fashion.

Approximately 177 vehicles are affected by this recall.

All customers affected by this Recall are being sent letters by February 2017. The letter will inform them that their vehicle is affected by this Recall. To assist you with customer concerns, please reference the attached Q & A that will be updated as information becomes available.



AFFECTED VEHICLES

This Recall Campaign involves 177 Model Year 2017 i3 and i8 vehicles.

Vehicles in dealer inventory are affected by this recall/stop. Vehicles which require this Recall Campaign to be completed will show it as "Open" when checked either in AIR, the "Service Menu" of DCSnet (Dealer Communication System) or with the Key Reader.

The affected vehicles will be identified with the comment:



Note: **STOP811931 B72 01 17 AUTOLIV AIR BAG MODULE.**



CAUSE

Due to a supplier production error, certain air bags from supplier Autoliv may not have been produced to specifications.



CORRECTION

Replace the affected Air Bag Module.



PROCEDURE

Vehicles I12:

Only the front passenger air bag must be replaced. See repair instructions REP 72 12 000 "Remove and install/replace the air bag module on the passenger's side"

Vehicles I01:



Refer to the weekly parts matrix DCS message for the parts ordering procedure. The parts department will determine which Knee Air Bag Module to ship you for replacement.

Replace the knee air bag. See repair instructions:

REP 72 12 004 "Removing and installing/replacing the air bag module for driver's knee protection"

or

REP 72 12 006 "Removing and installing/replacing the air bag module for front passenger knee protection"



PARTS INFORMATION

For the I12:		
Part Number	Description	Quantity
72 12 9 289 695	Front-passenger side air bag module	1
07 14 9 321 690	Cap screwM10X28	4
For the I01:		
Part Number	Description	Quantity
72 12 9 281 072	Right knee protection air bag	1
72 12 9 265 943	Left knee protection air bag	1
07 14 9 242 146	Self-tapping oval-head screw ISA 6X13	2 per air bag

Important! Retention of Used Parts

The parts replaced and submitted through this Recall claim entry procedure are the property of BMW NA.



Attention: Inflatable air bags are classified as dangerous goods by the Department of Transportation (DOT) and require special preparation, packing and labeling for transport.

Your center is responsible for following all rules and regulations that apply to the proper shipping of dangerous goods.

Dealers can use the Labelmaster® Dangerous Goods Information System (DGIS) for proper shipping procedures and guidelines to the WPRC. (Additional information for the DGIS can be found in SI B01 22 16)

Your center is responsible for the proper identification, storage and documentation of these parts. They must be held in a secure retention area until notification of claim payment is made by BMW NA through DCSnet.

A DCSnet part return tag will be generated for the requested parts. Inflatable air bags are classified as dangerous goods by department of transportation (DOT) and require special preparation, packing and labeling for transport.

Please DO NOT return these recalled air bag modules directly to the supplier. They are to be returned to the Warranty Parts Return Center. Be sure to review each part return tag to verify the proper “ship to” location.

Any parts not received by the WPRC within the 45 day part submission timeline may be subject to a claim debit.

UPDATE! **WARRANTY**

Reimbursement for this Recall will be via normal claim entry utilizing the following information:

Defect Code:	0072760100	
---------------------	-------------------	--

Completion “before” vehicle delivery to the customer or the vehicle is already in the workshop (Plus work)

I01 (i3)

Labor Operation:	Labor Allowance:	Description:
00 64 801	7 FRU	Replace driver's side knee air bag (only I01)
00 64 802	10 FRU	Replace both knee air bags (only I01)
00 64 803	5 FRU	Replace passenger's side knee air bag (only I01)

I12 (i8)

Labor Operation:	Labor Allowance:	Description:
00 64 775	45 FRU	Replace front passenger air bag (only I12)

Completion after vehicle delivery to the customer (Main work)
I01 (i3)

Labor Operation:	Labor Allowance:	Description:
00 64 263	8 FRU	Replace driver's side knee air bag (only I01)
00 64 264	11 FRU	Replace both knee air bags (only I01)
00 64 265	7 FRU	Replace passenger's side knee air bag (only I01)

I12 (i8)

Labor Operation:	Labor Allowance:	Description:
00 64 262	47 FRU	Replace front passenger air bag (only I12)

ATTACHMENTSView PDF attachment [B720117 Q&A](#).View PDF attachment [Recall Notice B720117](#).View PDF attachment [REP 72 12 000 - i8 Passenger air bag](#).View PDF attachment [REP 72 12 004 - i3 Drivers Knee airbag](#).View PDF attachment [REP 72 12 006 - i3 Passengers Knee airbag](#).

[Copyright ©2017 BMW of North America, Inc.]

SAFETY RECALL NOTICE

To: All Center Operators, Sales Managers, Service Manager, Parts Manager and Warranty Processor

RE: Recall Campaign 16V-914: Autoliv Air Bag Modules – B72 01 17

BMW Group is conducting a Voluntary Safety Recall (effective December 15, 2016) involving the Autoliv Air Bag Module(s) in certain I01 (i3), I01 (i3 Rex) and I12 (i8).

Owners will be notified by First Class mail about the Recall and will be instructed to bring their vehicles in for a free repair when parts are available.

Please be reminded that it is a violation of federal law (The Safety Act) for you to sell, lease or deliver any new motor vehicle covered by this notification until the recall repair has been performed. This means that centers may not legally deliver new motor vehicles to consumers until they are fixed or use/sell replacement equipment/parts subject to this recall. Note also that substantial civil penalties apply to violations of the Safety Act.

Also, you should not sell, lease or deliver any Certified Pre-Owned or used vehicles subject to a safety recall until the repair is completed.

Please follow any special instructions that we provide to you for the return or disposition of recall parts.

We appreciate all your assistance with this Recall.

**Autoliv Air Bags
Safety Recall 16V-914
Model Year 2016-2017
BMW, MINI, Rolls-Royce
Last Updated 12/15/2016**

Q1. Which BMW Group models in the US are potentially affected by this Safety Recall?

Approximately 3,506 BMW Group vehicles (2,257 BMW, 1,221 MINI, 28 Rolls-Royce) in the US, as noted below, are potentially affected.

Series	Model	Model Year	Approx. Volume	Production Dates (2016)
F06	6 Series Gran Coupe (incl. M6)	2017	41	Sep – Oct
F07	5 Series Gran Turismo (not incl. 550xi)	2017	2	Sep – Oct
F10	5 Series Sedan (incl. Hyb.)	2016	99	Sep – Oct
F12	6 Series Convertible (incl. M6)	2017	102	Sep – Nov
F13	6 Series Coupe (incl. M6, not incl. 640xi, 650i)	2017	10	Oct
F33/F83	4 Series Convertible (incl. M)	2017	295	Aug – Sep
F48	X1 SAV	2017	1,531	Aug – Dec
F54	Clubman (incl. S, All4)	2017	528	Aug – Oct
F55	4-Door (incl. S)	2017	192	Aug – Sep
F56	2-Door (incl. S, JCW)	2017	346	Aug – Sep
F57	Convertible (incl. S, JCW)	2017	155	Aug – Sep
I01	i3 (BEV, REX)	2017	173	Sep
I12	i8	2017	4	Nov
RR6	Dawn	2017	28	Aug – Sep

Q2. What is the specific issue?

This safety recall involves certain air bags from supplier Autoliv which may not have been produced to specifications. Depending upon vehicle model, and specific VIN, the specific air bag, e.g., front passenger, front seat-mounted side (driver / passenger), head (left-side, right-side), knee (driver / passenger) could be affected.

Q2a. Is this issue related to Takata Air Bags?

No.

**Autoliv Air Bags
Safety Recall 16V-914
Model Year 2016-2017
BMW, MINI, Rolls-Royce
Last Updated 12/15/2016**

< continued on next page >

Q2b. Which specific air bag is affected on my vehicle?

Affected air bags, by vehicle model, are as noted below:

Series	Model	Model Year	Air Bag Affected
F06	6 Series Gran Coupe (incl. M6)	2017	Front (passenger)
F07	5 Series Gran Turismo (not incl. 550xi)	2017	Front (passenger)
F10	5 Series Sedan (incl. Hyb.)	2016	Front (passenger)
F12	6 Series Convertible (incl. M6)	2017	Front (passenger), Front seat-mounted side (driver/passenger)
F13	6 Series Coupe (incl. M6, not incl. 640xi, 650i)	2017	Front (passenger)
F33/F83	4 Series Convertible (incl. M)	2017	Front seat-mounted side (driver/passenger)
F48	X1 SAV	2017	Knee (driver/passenger), Head (left-side)
F54	Clubman (incl. S, All4)	2017	Knee (driver/passenger), Head (left-side/right-side)
F55	4-Door (incl. S)	2017	Knee (driver/passenger)
F56	2-Door (incl. S, JCW)	2017	Knee (driver/passenger)
F57	Convertible (incl. S, JCW)	2017	Knee (driver)
I01	i3 (BEV, REX)	2017	Knee (driver/passenger)
I12	i8	2017	Knee (driver/passenger)
RR6	Dawn	2017	Front seat-mounted side (driver/passenger)

Q3. What can happen as a result of this issue?

If the air bag was not produced to specifications, then in a crash of sufficient severity, the air bag may not deploy, increasing the risk of injury.

**Autoliv Air Bags
Safety Recall 16V-914
Model Year 2016-2017
BMW, MINI, Rolls-Royce
Last Updated 12/15/2016**

Q4. How did BMW Group become aware of this issue?

BMW Group became aware of this issue through its quality control procedures.

Q5. Why are other BMW Group vehicles not included in this Safety Recall?

Other vehicles were equipped with Autoliv air bags that were produced to specifications.

Q6. Can I determine if this issue exists in my vehicle?

No.

Q7. Can I continue to drive my vehicle?

Yes.

However, when you receive a letter asking you to have this recall performed by an authorized BMW center (or, MINI dealer, or Rolls-Royce Motor Cars dealer), please do so as soon as possible. If you are not the only driver of this vehicle, please advise all other drivers of this important information.

Q8. How will my vehicle be repaired?

The air bag(s) will be replaced.

Q9. Is BMW Group aware of any accidents, injuries, or fires involving these BMW Group vehicles associated with this Safety Recall?

No.

Q10. How will I be informed of this Safety Recall?

You will receive a letter in February via First Class mail advising you of this recall and to immediately schedule an appointment with an authorized BMW center (or, MINI dealer, or Rolls-Royce Motor Cars dealer) to have this recall performed.

- You can locate your nearest authorized BMW center at www.bmwusa.com/dealer.
- You can locate your nearest authorized MINI dealer at www.miniusa.com/dealer.
- You can locate your nearest authorized Rolls-Royce Motor Cars dealer at www.rollsroycemotorcars.com/dealer.

- To ensure BMW has your most recent contact and vehicle information, please register your vehicle at www.bmwusa.com/myBMW.
- To ensure MINI has your most recent contact and vehicle information, please register your vehicle at www.miniusa.com/ol.

**Autoliv Air Bags
Safety Recall 16V-914
Model Year 2016-2017
BMW, MINI, Rolls-Royce
Last Updated 12/15/2016**

Registration is free, and will give you access to factory initiated campaigns and other information specific to your BMW (or MINI).

Q11. How long will the repair take?

This repair may take several hours; however, additional time may be required depending upon your BMW center's (or, MINI dealer's, or Rolls-Royce Motor Cars dealer's) schedule. The repair will be performed free of charge by your authorized BMW center (or, MINI dealer, or Rolls-Royce Motor Cars dealer).

Q12. Do I have to wait for my letter in order to have my vehicle serviced?

Yes. we are in the process of implementing this program to ensure that the necessary parts, tools and procedures are available, prior to contacting you to schedule your vehicle to have this safety recall performed.

- For the latest updates to this recall, please visit www.bmwusa.com/recall.
- For the latest updates to this recall, please visit www.miniusa.com/recall.
- For the latest updates to this recall, please visit www.rolls-roycemotorcars.com/recall.

REP-REP-RAI1272-7212000 Removing and installing or replacing airbag module on passenger's side; VIN: XXXXXXXX

ISTA system version	4.02.22.18112	Data version	R4.02.22.18112	Programming data	-
VIN	XXXXXXXX	Vehicle	I/I12/Coupe/i8/B38/AUT/US/left-hand drive/2015/09		
Int.lev.works	-	Int.lev.(cur.)	-	Int.lev.(tar.)	-
Mileage	0 km				

72 12 000

Removing and installing or replacing airbag module on passenger's side

**Important!**

Operations on pyrotechnical devices may only be carried out by authorised experts.

Improper, unauthorised operations may result in serious dangers.

Unauthorized persons are strictly prohibited from performing any operations on this system.

**Warning!**

Read and comply with [safety instructions](#) for handling airbag modules and pyrotechnical belt tensioners.

Incorrect handling can activate airbag and cause injury.

A damaged airbag must be replaced

because its protective function is compromised or, in an extreme situation, it can no longer execute its protective function.



Necessary preliminary tasks:

- Remove [instrument panel trim](#)



Removal:

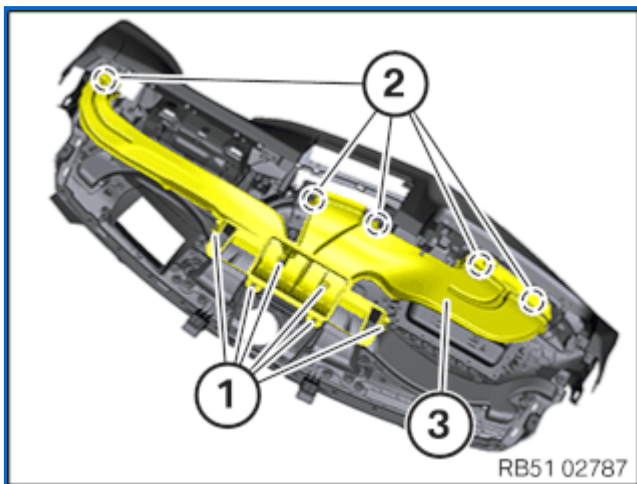

Release screws (1) and the expanding rivets (2).

Feed out air duct (3) and remove.

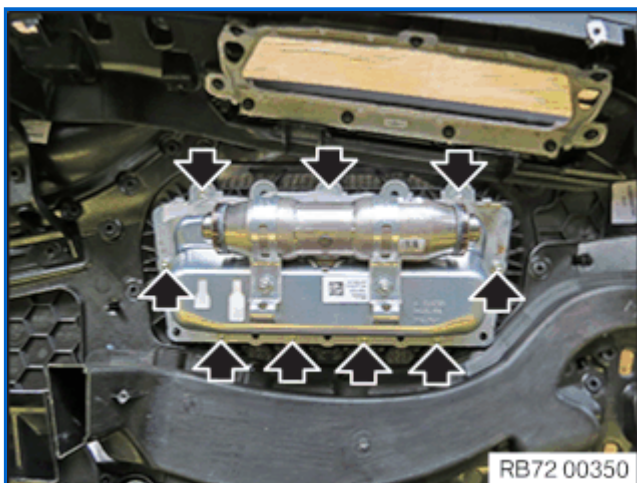

Release screws on airbag module.

Remove airbag module from dashboard.



Installation:

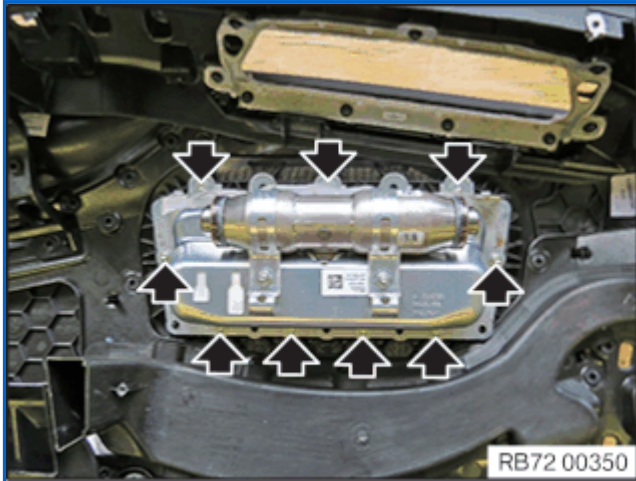

Attach airbag module to instrument panel.

Tighten screw on airbag module.

Tightening torque [72 12 01AZ](#).

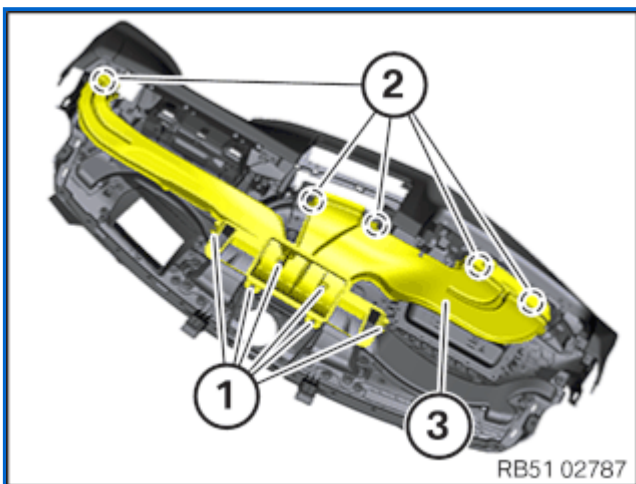

Feed in air duct (3).

Tighten screws (1) and secure the expanding rivets (2).



Required follow-up work:

- Install [instrument panel trim](#)

REP-REP-RAI0172-7212004 Removing and installing/replacing airbag module for driver's knee protection; VIN: XXXXXXXX

ISTA system version	4.02.22.18112	Data version	R4.02.22.18112	Programming data	-
VIN	XXXXXXX	Vehicle	I/I01/HAT/i3/IB1/AUT/US/left-hand drive/2016/06		
Int.lev.works	-	Int.lev.(cur.)	-	Int.lev.(tar.)	-
Mileage	0 km				

72 12 004

Removing and installing/replacing airbag module for driver's knee protection



Warning!

High-voltage system - danger to life!

The following points must be strictly observed **prior to starting work**:

Disconnect [high-voltage system](#) from power.

Observe [safety information](#) for handling electric vehicles.



Warning!

Read and comply with [safety regulations](#) for handling airbag modules and pyrotechnical belt tensioners.

Incorrect handling can activate airbag and cause injury.



Important!

Operations on pyrotechnical devices may only be carried out by authorised experts.

Improper, unauthorised operations may result in serious dangers.

Unauthorized persons are strictly prohibited from performing any operations on this system.



Necessary preliminary tasks:

- Clamp off [battery earth lead](#)
- Removing [centre dashboard trim panel](#)

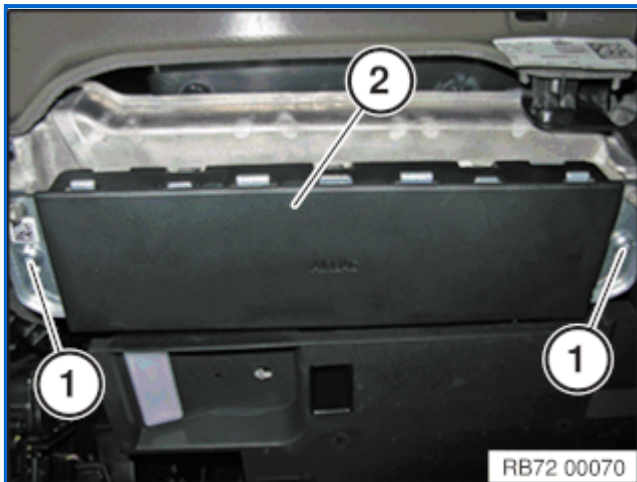

Release screws (1).

Tightening torque [72 12 02AZ](#).

Airbag module (2) is coded against incorrect assembly.

Unfasten plug connection (1) [and disconnect](#).

Remove airbag module.

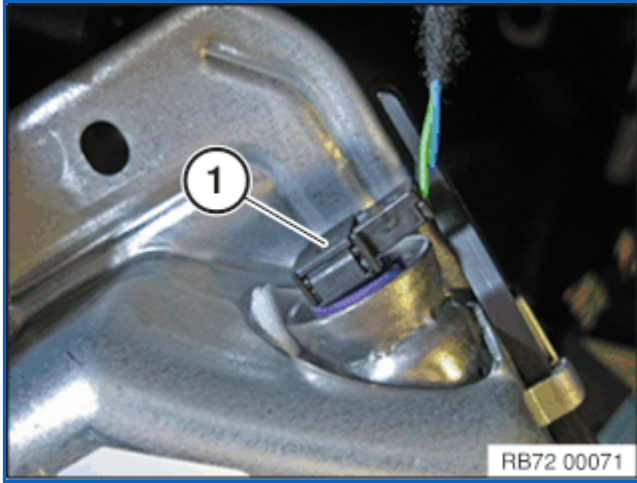

REP-REP-RAI0172-7212006 Removing and installing/replacing airbag module for passenger knee protection; VIN: XXXXXXXX

ISTA system version	4.02.22.18112	Data version	R4.02.22.18112	Programming data	-
VIN	XXXXXXX	Vehicle	I'/I01/HAT/i3/IB1/AUT/US/left-hand drive/2016/06		
Int.lev.works	-	Int.lev.(cur.)	-	Int.lev.(tar.)	-
Mileage	0 km				

72 12 006

Removing and installing/replacing airbag module for passenger knee protection

**Warning!**

High-voltage system - danger to life!

The following points must be strictly observed **prior to starting work**:

Disconnect [high-voltage system](#) from power.

Observe [safety information](#) for handling electric vehicles.

**Warning!**

Read and comply with [safety regulations](#) for handling airbag modules and pyrotechnical belt tensioners.

Incorrect handling can activate airbag and cause injury.

**Important!**

Operations on pyrotechnical devices may only be carried out by authorised experts.

Improper, unauthorised operations may result in serious dangers.

Unauthorized persons are strictly prohibited from performing any operations on this system.

**Necessary preliminary tasks:**

- Clamp off [battery lead from negative connection point](#)
- Removing [centre dashboard trim panel](#)

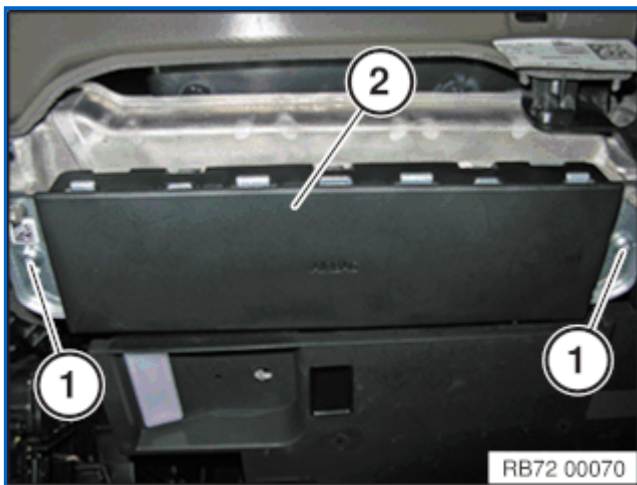

Release screws (1).

Tightening torque [72 12 02AZ](#).

Airbag module (2) is coded against incorrect assembly.

Unfasten plug connection (1) [and disconnect](#).

