

Q651NAS1

TECHNICAL BULLETIN

22 DEC 2016



© Jaguar Land Rover North America, LLC

NOTE: The information in Technical Bulletins is intended for use by trained, professional Technicians with the knowledge, tools, and equipment required to do the job properly and safely. It informs these Technicians of conditions that may occur on some vehicles, or provides information that could assist in proper vehicle service. The procedures should not be performed by 'do-it-yourselfers'. If you are not a Retailer, do not assume that a condition described affects your vehicle. Contact an authorized Land Rover service facility to determine whether this bulletin applies to a specific vehicle.

INFORMATION

SECTION:

204-01

SUBJECT/CONCERN:

SAFETY RECALL: Right Hand Lower Control Arm to Knuckle Joint Over-Torqued

AFFECTED VEHICLE RANGE:

MODEL:	MODEL YEAR:	VIN:	ASSEMBLY PLANT:
Discovery Sport (LC)	2016-2017	612686-641815	Halewood
Range Rover Evoque (LV)	2016-2017	159180-176858	Halewood

MARKETS:

NAS

CONDITION SUMMARY:

SITUATION:

An issue has been identified on certain vehicles within the listed Affected Vehicle Range where the front right suspension lower control arm-to-wheel knuckle fastener may fail due to a manufacturing process error.

ACTION:

Retailers are required to **HOLD** affected new vehicles that are within your control and refrain from releasing the vehicles for **new vehicle sale** pending completion of the Service Instruction detailed in this Technical Bulletin. Unsold vehicles should have this performed as part of the Pre-Delivery Inspection (PDI) process but **must** have it completed prior to vehicle handover to the customer.

Affected vehicles already in the hands of customers should be updated at the next available opportunity.

PARTS:

NOTES:

- Order only the expected percentage demand of parts identified and in quantities to perform immediate repairs.
- Provide the VIN in the Customer Material Number field for all parts orders.

DESCRIPTION	PART NO. /SUNDRY CODE	QTY. /VALUE	EXPECTED % OF VEHICLES REQUIRING PARTS
Bolt M12 x 130 - Range Rover Evoque (L538; Coupe, 5-Door)	LR024506	1	100
Bolt M12 x 112 - Discovery Sport (L550); Range Rover Evoque Convertible (L538c)	LR024747	1	100
Hex Nut M12	FY112056	1	100
Brake Caliper Bolt M12 x 42	LR058339	2	100

SPECIAL TOOLS:

Refer to Workshop Manual/Service Instruction for any required special tools.

WARRANTY:

NOTES:

- Check DDW to ensure that a vehicle is affected by this program prior to undertaking any rework action.
- Check vehicle for program code Q650 eligibility. If eligible, perform and claim at the same time as this program.

At the time of confirming a booking for vehicle repair, ensure that **all** outstanding Recalls and Service Actions are identified to ensure the correct parts are available and adequate workshop time is allocated for repairs to be completed at one visit.

Warranty claims must be submitted quoting the Program Code together with the relevant Option Code. SRO and parts information is included for information only. The Option Code(s) that allows for the drive in / drive out allowance can only be claimed if the vehicle is brought back into the workshop for this action alone to be undertaken.

Repair procedures are under constant review and therefore times / prices are subject to change; those quoted here must be taken as guidance only. Refer to TOPIx to obtain the latest repair time.

Warranty claims must be submitted or payment within 30 calendar days of completion of the repair.

PROGRAM CODE	OPTION CODE	DESCRIPTION	SRO	TIME (HOURS)	PARTS /SUNDRY CODE	QTY. /VALUE
Q651	B	Lower Control Arm Fixing - Right - Renew	60.90.26	0.40	LR024506 LR024747 FY112056 LR058339	1 1 1 2
Q651	C	Lower Control Arm Fixing - Right - Renew	60.90.26	0.40	LR024506 LR024747 FY112056 LR058339	1 1 1 2
		Drive in/drive out	02.02.02	0.20	-	-

Normal Warranty policies and procedures apply.

SERVICE INSTRUCTION:

⚠ CAUTION:

Nuts and bolts must be tightened with the weight of the vehicle on the suspension.

1

⚠ WARNING:

Make sure to support the vehicle with axle stands.

Remove the front right wheel (see TOPIx Workshop Manual section 204-04: Wheels and Tires - Removal and Installation - Wheel and Tire).

2

⚠ CAUTION:

Make sure the weight of the front brake caliper and carrier assembly is supported.

△ NOTE:

Front left shown; front right similar.

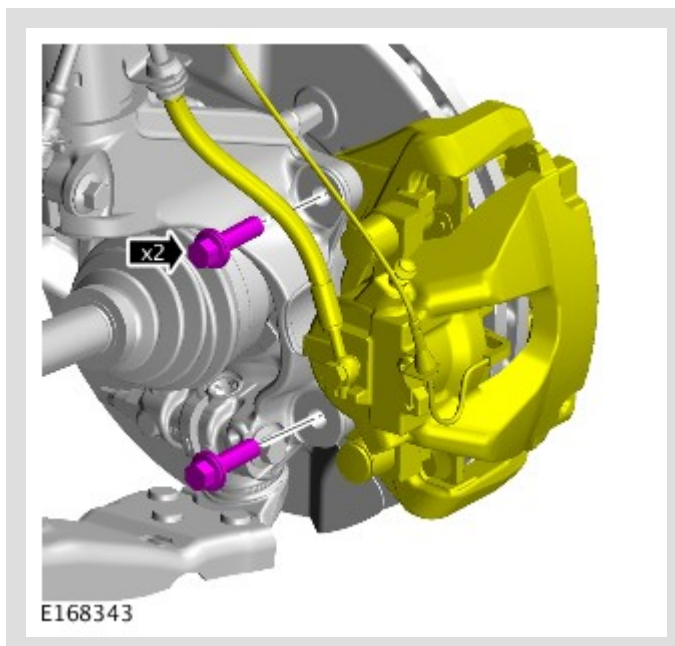

Remove the two bolts from the front right brake caliper carrier and reposition the brake caliper and carrier assembly.

3

NOTES:

- Take note of the orientation of the bolt.
- Discard the used nut and bolt.
- Front left shown; front right similar.

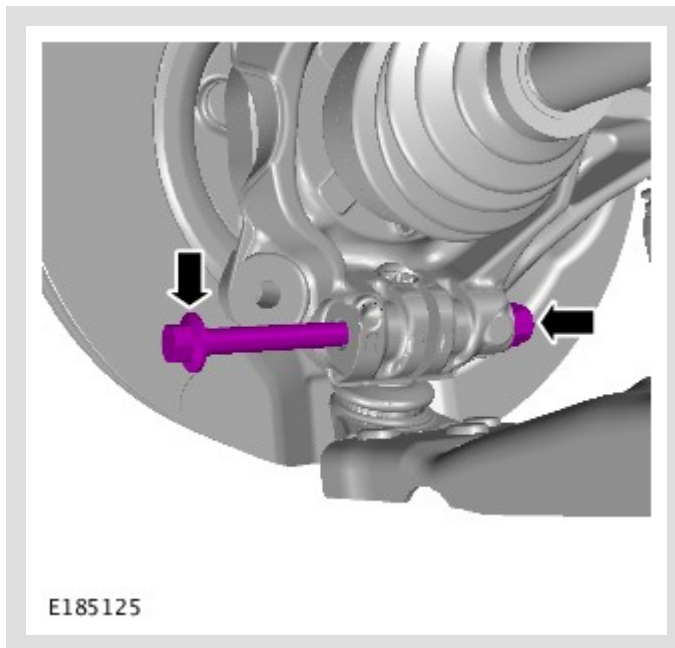

Remove and discard the nut and bolt from the front right wheel knuckle-to-lower ball joint interface.

4

CAUTION:

Make sure that a new nut and bolt are installed.

NOTES:

- Make sure to install the new bolt in the same orientation.

- Front left shown; front right similar.

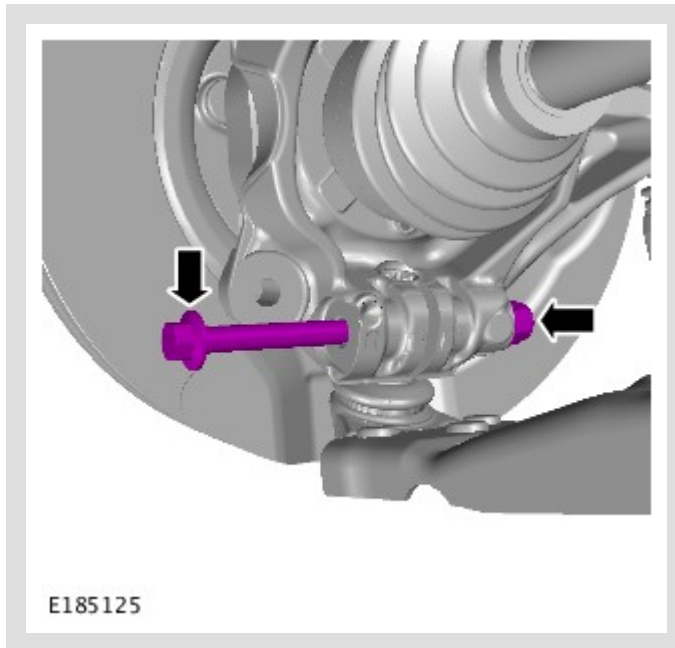

Install a new nut and bolt to the front right wheel knuckle-to-lower ball joint interface.

Torque - **Stage 1: 80Nm Stage 2: 180°**

5

 **NOTES:**

- **Make sure that new bolts are installed.**
- **Front left shown; front right similar.**

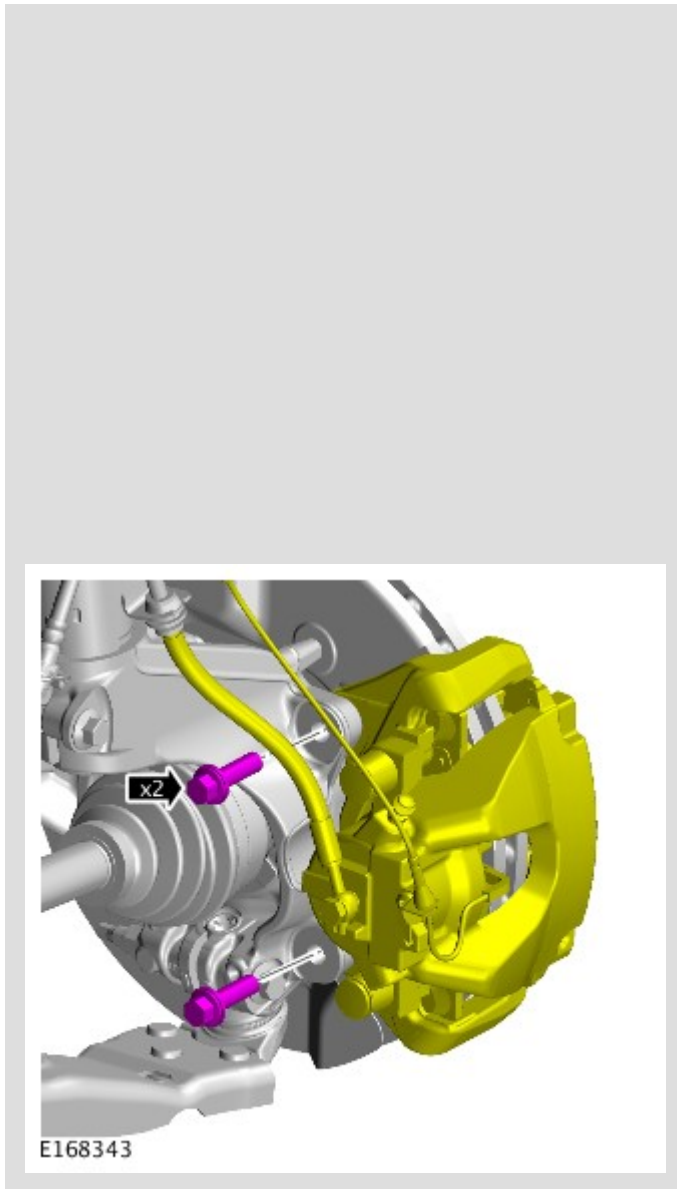

Install the front right brake caliper and carrier assembly.

Torque - **Stage 1: 90Nm Stage 2: 120°**

- 6 Install the front right wheel (see TOPIx Workshop Manual section 204-04: Wheels and Tires - Removal and Installation - Wheel and Tire).
- 7 Lower the vehicle.