

AG09 - Replacing Lower Suspension Arms for Front Axle (Recall Campaign)

Vehicle Type: **918 Spyder**

Model Year: **As of 2014 up to 2015**

Concern: **Lower suspension arms for front axle**

Information: **The front axle of the Porsche 918 Spyder was fitted with lower suspension arms from a batch whose durability cannot be guaranteed due to a manufacturing error.**

The affected components can start to crack, causing the component to break and as a result, vehicle handling can be impaired.

Remedial Action: Replace lower suspension arms for front axle.



Information

The vehicle must be checked for defects and damage (damage to paintwork, missing parts, etc.) **each time** it is handed over, transferred or delivered. Confirmation that the vehicle is in good condition or details of any damage to the vehicle must be documented and archived for feedback purposes.

Service Level: **This campaign must be carried out by a Service Level 2 Porsche Dealer.**

Service Level 0 or 1 Dealers are NOT authorized to carry out this campaign. In accordance with the service concept for the 918 Spyder, the vehicle must be transferred to a Service Level 2 Dealer in order to carry out this recall. If the vehicle should require transport from your dealership to a Level 2 Dealer and transportation has not previously been arranged by the 918 Client Relationship Team, you should contact Roadside Assistance at 1-844-918-SPYD (7793) to facilitate the transfer. Instructions for claiming the appropriate transport costs are outlined in Attachment B. Further information can be found under Attachment "B" at the end of this document.

The vehicle must be checked for defects and damage **each time** it is handed over, transferred or delivered. Confirmation that the vehicle is in good condition or details of any damage to the vehicle must be documented and archived for feedback purpose.

Affected Vehicles: The VIN(s) can be checked by using PIWIS Vehicle Information link to verify if the campaign affects the vehicle. This campaign is scope specific to the VIN! Failure to verify in PIWIS may result in an improper repair. This campaign affects 332 vehicles in North America.

Installation
Position:

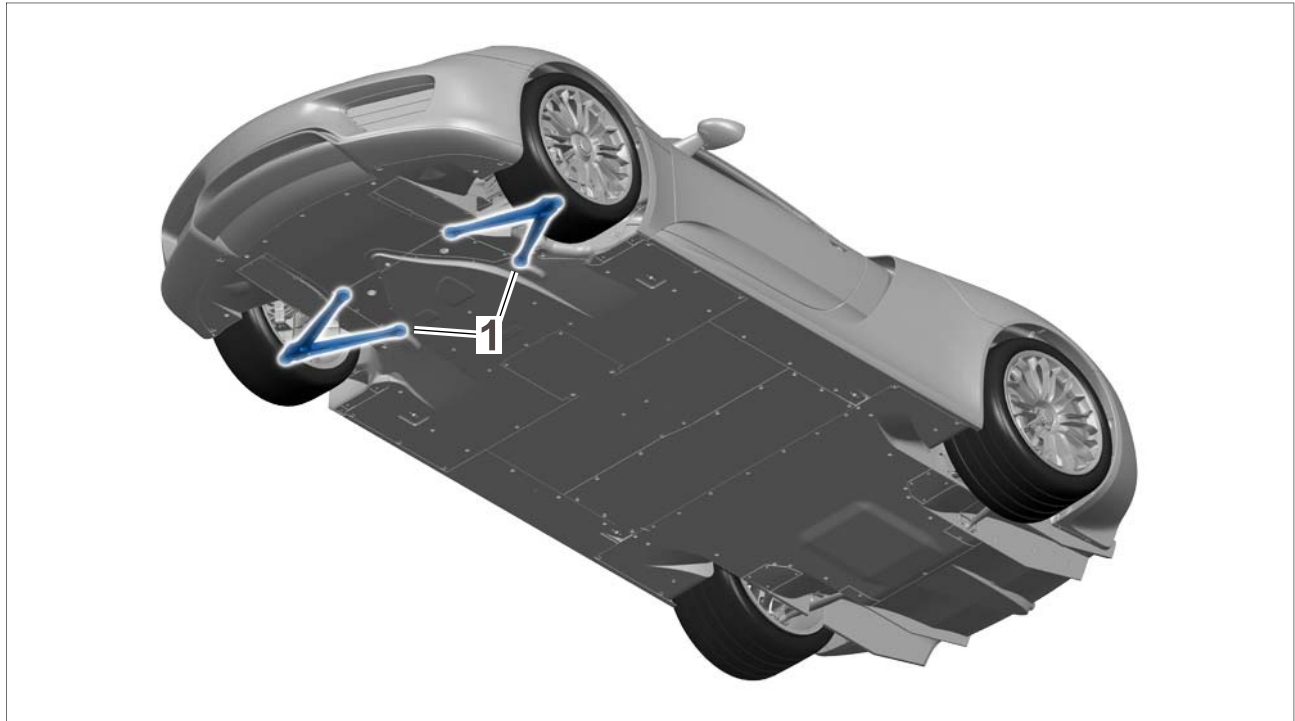

Overview of lower suspension arms for front axle

1 – Lower suspension arm for front axle (**replace**)

Required parts and materials

Parts Info: **NOTE: PARTS WILL NOT BE AUTOMATICALLY ALLOCATED TO YOUR DEALERSHIP. ALL PARTS MUST BE ORDERED VIA A PTEC/PAV.**

Part No.	Designation	Qty.
918 341 053 02	⇒ Lower suspension arm for front axle	2 ea.

The following parts are also required for each vehicle:

- Vehicles with **Racetrack (Weissach) package (I-no. 808)**:

Part No.	Designation – Use	Qty.
000 043 306 64	⇒ Set of fastening parts for Racetrack package – Lower suspension arm for front axle	2 ea.

Includes:

999 311 502 02	Fit bolt, M12 x 1.5 – Lower suspension arm to auxiliary support	2 ea.
999 311 604 02	Fit bolt, M10 x 1.5 x 81 - Tie rod to wheel carrier	1 ea.
999 311 606 02	Fit bolt, M10 x 1.5 x 72 – Spring strut to lower suspension arm	1 ea.
999 311 602 02	Fit bolt, M10 x 1.5 x 65 – Upper suspension arm to wheel carrier	1 ea.
999 073 572 01	Lens-head screw, M6 x 8 – Brake disc to wheel hub	2 ea.
999 084 449 09	Hexagon nut, M12 x 1.5 – Lower suspension arm to wheel carrier	1 ea.
999 084 656 01	Hexagon nut, M10 – Upper suspension arm to wheel carrier – Tie rod to wheel carrier – Connecting link to wheel carrier – Brake caliper to wheel carrier – Spring strut to lower suspension arm	6 ea.

or

- Vehicles **without** Racetrack (Weissach) package:

Part No.	Designation – Use	Qty.
000 043 306 63	⇒ Set of fastening parts – Lower suspension arm for front axle	2 ea.

Includes:

999 311 502 01	Fit bolt, M12 x 1.5 – Lower suspension arm to auxiliary support	2 ea.
999 311 604 01	Fit bolt, M10 x 1.5 x 81 - Tie rod to wheel carrier	1 ea.
999 311 606 01	Fit bolt, M10 x 1.5 x 72 – Spring strut to lower suspension arm	1 ea.

999 311 602 01	Fit bolt, M10 x 1.5 x 65 – Upper suspension arm to wheel carrier	1 ea.
999 073 572 01	Lens-head screw, M6 x 8 – Brake disc to wheel hub	2 ea.
999 084 449 09	Hexagon nut, M12 x 1.5 – Lower suspension arm to wheel carrier	1 ea.
999 084 656 01	Hexagon nut, M10 – Upper suspension arm to wheel carrier – Tie rod to wheel carrier – Connecting link to wheel carrier – Brake caliper to wheel carrier – Spring strut to lower suspension arm	6 ea.

Materials: **Required materials** (usually already available in the Porsche Dealer, only order if additional materials are required):

Part No.	Designation – Use	Qty.
000 043 302 72	⇒ Protective wax Pfinder AP14/4 – Threaded joint securing suspension arm to wheel carrier	100g tube As much as required
000 043 300 35	⇒ McLube Sailkote High Performance Dry Lube – Central wheel lock Also commercially available at marine supply stores.	428g spraying can As much as required
000 043 981 00	⇒ Autol Top 2000 grease – Conical area of suspension arm to wheel carrier	25 ml tube As much as required

Required tools

- Tools:
- **9002/1 - Lifting platform holders**
 - **9453 - Access ramps (or similar)**
 - **9003 - Socket wrench** for central wheel lock
 - **9004/1 - Socket wrench** for central wheel lock cover
 - Torque wrench, 150 – 800 Nm (111 – 592 ftlb.), e.g. **V.A.G. 1601 - Torque wrench 150-800 Nm (111-592 ftlb.)**
 - Torque wrench, 6 – 50 Nm (4.5 – 37 ftlb.), e.g. **V.A.G 1331 - Torque wrench, 6-50 Nm (4.5-37 ftlb.)**

- Torque wrench, 2 – 10 Nm (1.5 – 7.5 ftlb.), e.g. **V.A.G 1783 - Torque wrench, 2-10 Nm (1.5-7.5 ftlb.)**
- **9768 - Electronic torque wrench, 2 - 100 Nm (1.5 - 74 ftlb.) (or similar)**
- **VAS 6828 - Central Locking with Precision Aluminum Spoiler Adapter**
- **VAS 6826 - Steering wheel alignment gauge or similar**
- **9647 - Hook wrench**
- Suitable engine jack, e.g. **VAS 6931 - Engine and gearbox jack**
- **9900 - PIWIS Tester 3** for sensor calibration following suspension alignment
- Suitable battery charger, e.g. **VAS 5908 - Battery charger 90A** (charging current limit of max. 60 A required)

Work Procedure: See Attachment "A".

Claim Submission: See Attachment "B".

Attachment "A": **Work Procedure**

Preparatory work

Procedure: 1 Measure the vehicle height as well as the camber and toe adjustment values of the front axle and take note of the measured values ⇒ *Workshop Manual '449503 Suspension alignment, complete'*. To do this, raise the vehicle on a wheel alignment platform.



Information

The precision and calibration of the wheel alignment equipment to be used on this campaign must have been verified within the prior 365 days.

Given the narrow tolerances of the wheel alignment values and the variability of wheel alignment systems used at dealerships, the original factory wheel alignment values must be verified and recorded **before carrying out the campaign. A printed copy must be attached to the PQIS Job!**

Due to the large number of threaded joints on the chassis to be loosened as part of this campaign, the wheel alignment values must be verified and recorded again **after replacing the lower suspension arms for the front axle. A printed copy must be attached to the PQIS Job!** The **before and after** wheel alignment values must then be compared and adjustments made as necessary to restore the original factory values. This ensures optimal adjustment of the wheel alignment positions after replacing the suspension arms. **A printed copy must be attached to the PQIS Job!**

If, however, the individual wheel alignment values are **not within the prescribed adjustment tolerances** ⇒ *Workshop Manual '4X00IN Adjustment values for suspension alignment'* as a result of bumping into curbs, for example, the relevant wheel alignment positions must be set to the **wheel alignment values specified in the Workshop Manual** after **replacing** the suspension.

- 2 Raise the vehicle on a lifting platform ⇒ *Workshop Manual '4X00IN Lifting the vehicle'*.
 - 2.1 Position the vehicle between the arms of the lifting platform and push it onto the **9453 - access ramps (or similar)**.
 - 2.2 Remove underbody covers and fit mounting plates **9002/1 - Lifting platform holders**, ⇒ *Workshop Manual '518119 Removing and installing jacking points'*.
 - 2.3 Jack and raise the vehicle at the mounting plates.
- 3 Remove both front wheels ⇒ *Workshop Manual '440519 Removing and installing wheel'*.
- 4 Remove front wheel housing liner (front part) at the left and right ⇒ *Workshop Manual '50561901 Removing and installing front wheel housing liner (front part)'*.
- 5 Remove front wheel housing liner (rear part) at the left and right ⇒ *Workshop Manual '50561905 Removing and installing front wheel housing liner (rear part)'*.
- 6 Remove cover for center underbody (at the sides) at the left and right ⇒ *Workshop Manual '51931901 Removing and installing cover for centre underbody (at the sides)'*.
- 7 Remove front underbody cover ⇒ *Workshop Manual '519219 Removing and installing cover for front underbody'*.
- 8 Remove cover for center underbody ⇒ *Workshop Manual '51931900 Removing and installing cover for centre underbody'*.



Information

- **Do not open the brake hydraulic system (brake line remains connected).**

- 9 Remove front brake caliper at the left and right ⇒ *Workshop Manual '473919 Removing and installing front brake calliper'*.
Suspend the brake caliper on the vehicle using a tie-wrap, for example.
- 10 Remove front PCCB brake disc at the left and right ⇒ *Workshop Manual '465119 Removing and installing front PCCB brake disc'*.

Replacing lower suspension arms for front axle

- Procedure:
- 1 Remove lower suspension arm for front axle at the left.

- 1.1 Loosen and unscrew fastening nut ⇒ *Loosening tie rod -2-* on the tie rod ⇒ *Loosening tie rod -1-* on the wheel carrier. Remove fastening screw ⇒ *Loosening tie rod -3-* on the wheel carrier and pull out tie rod on the wheel carrier.

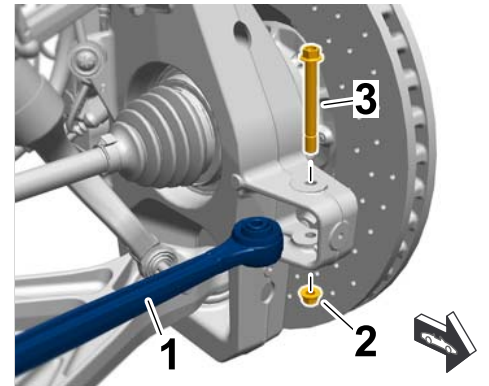

Loosening tie rod

- 1.2 Loosen and unscrew fastening nut ⇒ *Loosening front connecting link at the top -3-* on the connecting link ⇒ *Loosening front connecting link at the top -1-*. Remove connecting link from the anti-roll bar ⇒ *Loosening front connecting link at the top -2-* and turn it to the side.

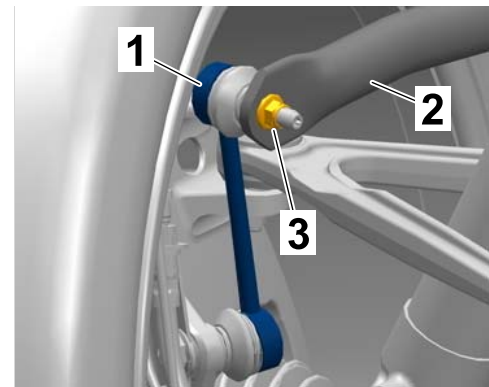

Loosening front connecting link at the top

NOTICE

Damage to the drive shaft

- Bellows can be overstrained or crack
 - Damage to the tripod joint
- ⇒ Support loosened wheel carrier using a suitable engine jack.
- ⇒ Carefully pull the wheel carrier outwards in order to remove the suspension arms.
- ⇒ Do NOT attempt to remove drive shafts!

- 1.3 Loosen and unscrew fastening nut ⇒ *Loosening upper suspension arm -2-* on the upper suspension arm ⇒ *Loosening upper suspension arm -1-*. Remove fastening screw ⇒ *Loosening upper suspension arm -3-*. Carefully press the wheel carrier ⇒ *Loosening upper suspension arm -4-* outwards and pull it off the upper suspension arm.

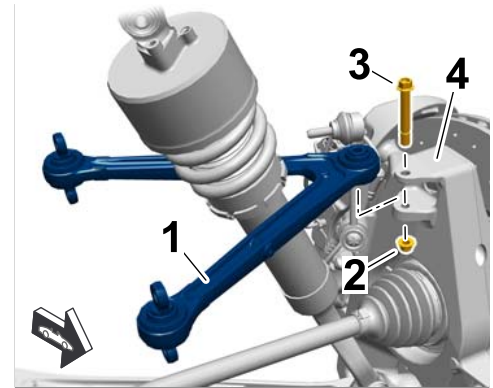

Loosening upper suspension arm

WARNING

Wheel carrier raised incorrectly

- Risk of crushing
 - Risk of damage to components
- ⇒ Wear personal protective gear.
- ⇒ Do not raise the wheel suspension higher than the normal vehicle position (vehicle resting on its wheels).
- ⇒ Use a suitable base, e.g. a rubber or plastic block.

- 1.4 Support the wheel carrier using a suitable transmission and unit carrier.
- 1.5 Loosen and unscrew fastening nut ⇒ *Loosening spring strut -3-* on the spring strut ⇒ *Loosening spring strut -1-*. Pull out and remove fastening screw ⇒ *Loosening spring strut -4-* on the lower suspension arm ⇒ *Loosening spring strut -2-*.

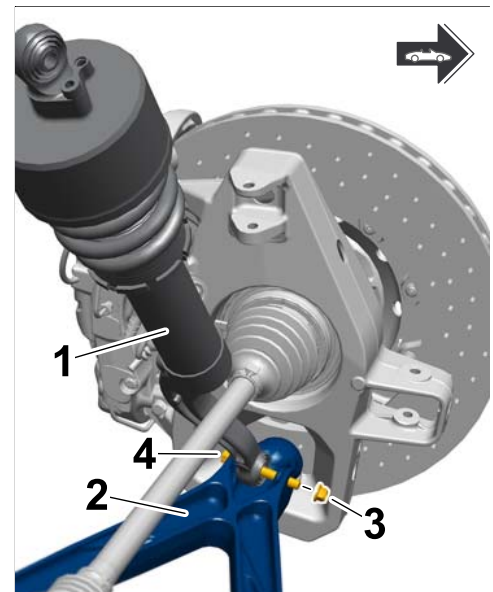

Loosening spring strut

NOTICE

Damage to the drive shaft

- Bellows can be overstrained or crack
 - Damage to the tripod joint
- ⇒ Support loosened wheel carrier using a suitable engine jack.
- ⇒ Carefully pull the wheel carrier outwards in order to remove the suspension arms.
- ⇒ Do NOT attempt to remove drive shafts!

- 1.6 Loosen and unscrew fastening nut ⇒ *Lower suspension arm on wheel carrier -2-* on the lower suspension arm on the wheel carrier. Press out ball pin ⇒ *Lower suspension arm on wheel carrier -1-* for the lower suspension arm on the wheel carrier. Loosen the ball pin from the wheel carrier by tapping gently with a plastic hammer if necessary.

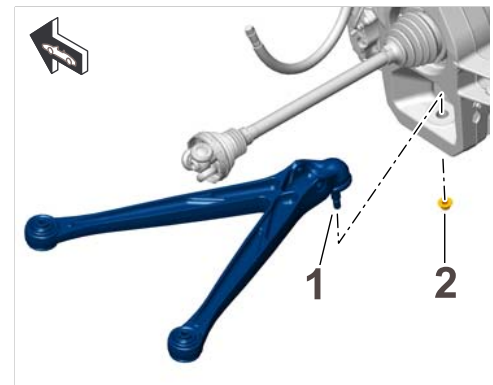

Lower suspension arm on wheel carrier

- 1.7 Loosen and unscrew fastening screws ⇒ *Lower suspension arm on front-axle carrier -1-* for the lower suspension arm on the front-axle carrier. Pull lower suspension arm out of the front-axle carrier and remove it.

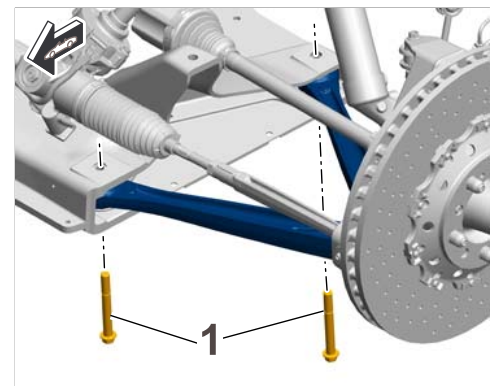

Lower suspension arm on front-axle carrier

- 2 Install new lower suspension arm for front axle at the left.



Information

Always use new fastening screws and lock nuts from the set of fastening parts.

- 2.1 Push lower suspension arm into the front-axle carrier. Screw in fastening screws ⇒ *Lower trailing arm on front-axle carrier -1-* for the lower suspension arm on the front-axle carrier and tighten using the **three-step tightening procedure**:
- Step 1 – Initial tightening: Tightening torque 80 Nm (59 ftlb.)
 - Step 2 – Loosening process: Torque angle 180°

- Step 3 – Final tightening: Tightening torque 80 Nm (59 ftlb.)

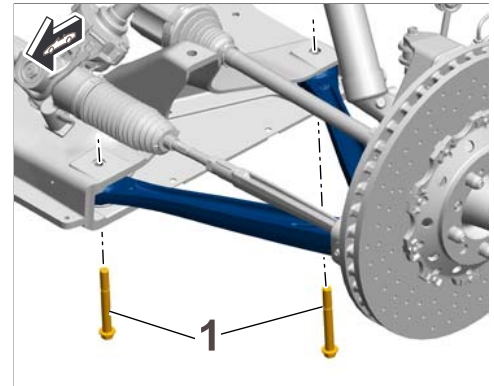

Lower trailing arm on front-axle carrier

- 2.2 Clean the fitting bore on the wheel carrier for the lower trailing arm ball pin thoroughly using a clean cloth.
- 2.3 Apply a thin coat of Autol Top 2000 grease, Part No. 000 043 981 00, to the conical area on the ball pin ⇒ *Greasing conical area -1-* for the lower trailing arm.

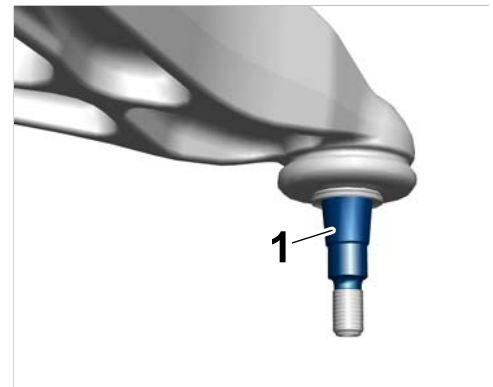

Greasing conical area

- 2.4 Carefully press the ball pin ⇒ *Lower suspension arm on wheel carrier -1-* of the suspension arm into the fitting bore on the wheel carrier.
Screw on new fastening nut ⇒ *Lower suspension arm on wheel carrier -2-*, Part No. 999 084 449 09, for lower suspension arm on the wheel carrier by only a few turns initially.

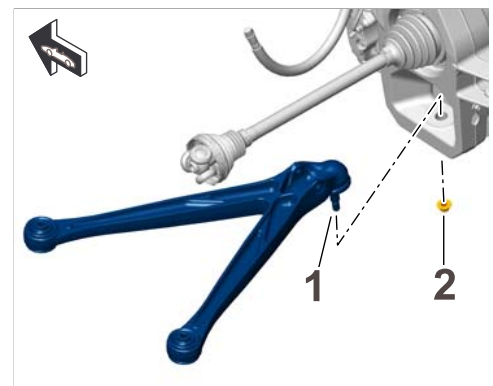

Lower suspension arm on wheel carrier

- 2.5 Press lower suspension arm ⇒ *Securing spring strut -2-* together with the wheel carrier up using the transmission and engine jack until the spring strut ⇒ *Securing spring strut -1-* is at the correct installation position on the suspension arm.
 Push in fastening screw ⇒ *Securing spring strut -4-* on the wheel carrier and spring strut and secure with the fastening nut ⇒ *Securing spring strut -3-*.
Tightening torque 55 Nm (41 ftlb.)
- 2.6 Remove transmission and engine jack.

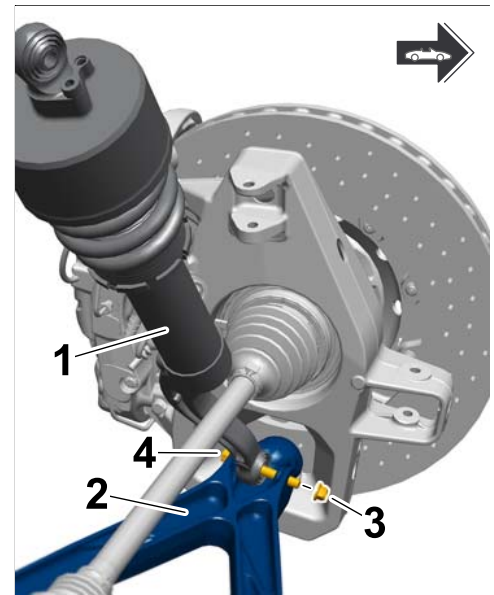

Securing spring strut

NOTICE

Incorrect positioning of the horizontal banner arm (lever arm) for level sensor

- Damage to the level sensor
 - Damage to the connecting link for the level sensor
- ⇒ Make sure that the ride height sensors and linkage is pointing outwards towards the wheel.
- ⇒ Do not bend the horizontal banner arm (lever arm) and connecting link or press them aside.

- 2.7 Position upper suspension arm on the wheel carrier.
Check that the horizontal banner arm (lever arm) ⇒ *Installation position of level sensor -1-* for the level sensor is positioned correctly ⇒ *Installation position of level sensor -top-*.

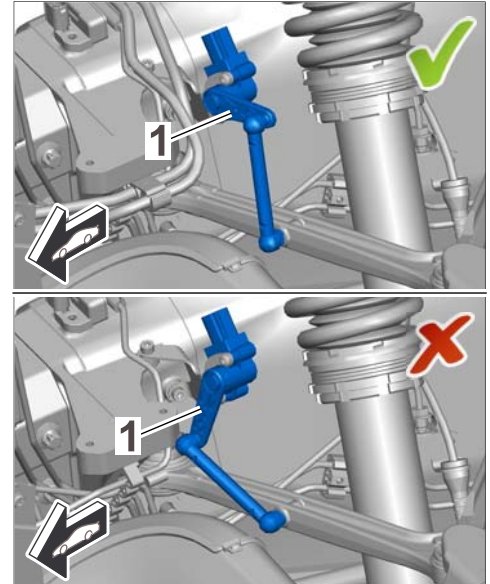

Installation position of level sensor

- 2.8 Push in fastening screw ⇒ *Securing upper suspension arm -3-* on the wheel carrier ⇒ *Securing upper suspension arm -4-* and upper suspension arm ⇒ *Securing upper suspension arm -1-* and secure with the fastening nut ⇒ *Securing upper suspension arm -2-*.

Tightening torque 42 Nm (31 ftlb.)

- 2.9 Position connecting link ⇒ *Securing front connecting link -1-* on the anti-roll bar ⇒ *Securing front connecting link -2-* and secure with the fastening nut ⇒ *Securing front connecting link -3-* using the **two-step tightening procedure**:

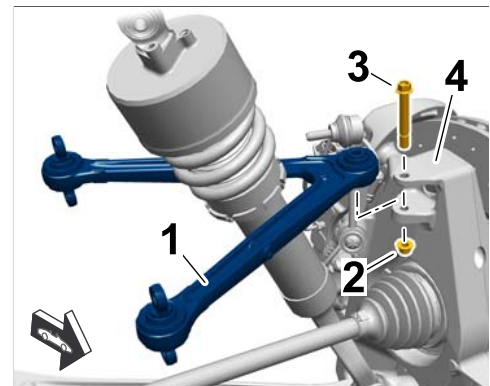

Securing upper suspension arm

- Step 1 – **Initial tightening:** Tightening torque 40 Nm (30 ftlb.)
- Step 2 – **Final tightening:** Torque angle 30°

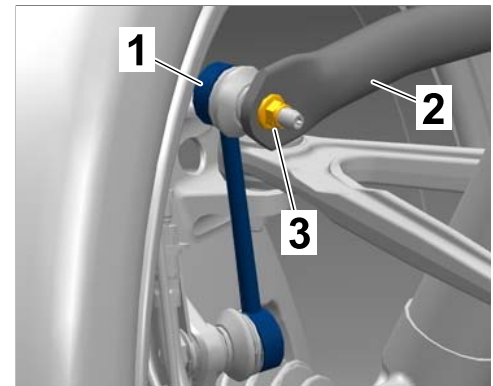

Securing front connecting link

2.10 Position tie rod ⇒ *Securing tie rod -1-* on the wheel carrier. Push in fastening screw ⇒ *Securing tie rod -3-* and secure with the fastening nut ⇒ *Securing tie rod -2-*.
Tightening torque 42 Nm (31 ftlb.)

2.11 Tighten fastening nut ⇒ *Lower suspension arm on wheel carrier -2-* for lower suspension arm using the **three-step tightening procedure**.

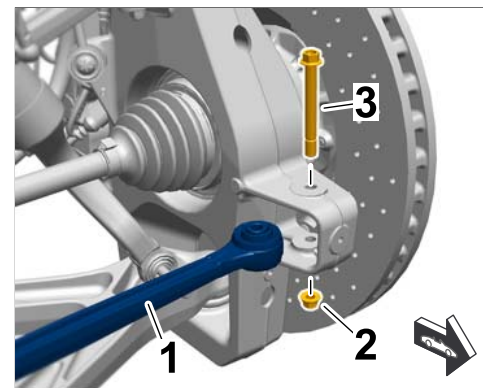

Securing tie rod



Information

Observe changed tightening torque for fastening nut for lower suspension arm and always comply with specifications.

- Step 1 – **Initial tightening:** Tightening torque 85 Nm (63 ftlb.) +/-2.5 Nm (+/-1.8 ftlb.)
- Step 2 – **Loosening process:** Torque angle 180°
- Step 3 – **Final tightening:** Tightening torque 85 Nm (63 ftlb.) +/-2.5 Nm (+/-1.8 ftlb.)

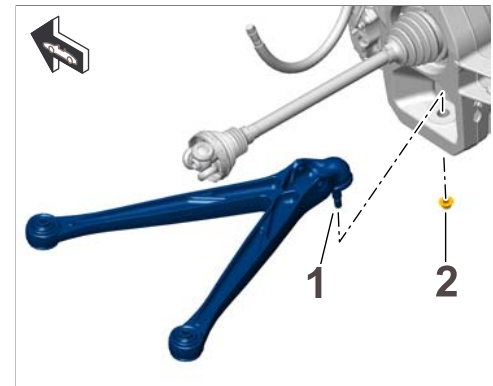

Lower suspension arm on wheel carrier



Information

Seal the threaded joint as shown in
 ⇒ *Applying wax on the suspension arm threaded joint* with protective wax Pfinder AP14/4, Part No. 000 043 302 72, after fitting. Cover the **projecting area of the thread**, the **hexalobular socket area** and the joints between the **nut and wheel carrier** and **nut and projecting area of the thread**, in particular, completely with wax.

- 3 Replace lower suspension arm for front axle at the right.
 To do this, carry out **Steps 1.1 to 2.11** on the **right-hand side of the vehicle**.

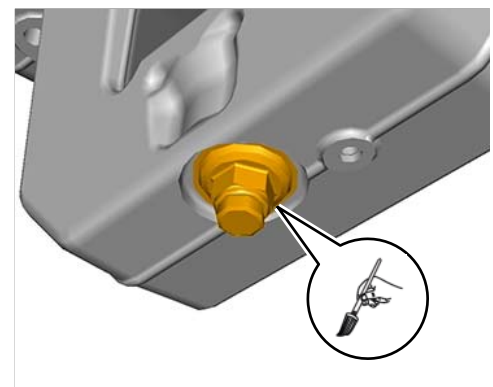

Applying wax on the suspension arm threaded joint

Concluding work

- Procedure:
- 1 Install front PCCB brake disc at the left and right ⇒ *Workshop Manual '465119 Removing and installing front PCCB brake disc'*.
 - 2 Install front brake caliper at the left and right ⇒ *Workshop Manual '473919 Removing and installing front brake calliper'*.
 - 3 Install cover for center underbody ⇒ *Workshop Manual '51931900 Removing and installing cover for centre underbody'*.
 - 4 Install front underbody cover ⇒ *Workshop Manual '519219 Removing and installing cover for front underbody'*.
 - 5 Install cover for center underbody (at the sides) at the left and right ⇒ *Workshop Manual '51931901 Removing and installing cover for centre underbody (at the sides)'*.

- 6 Install front wheel housing liner (rear part) at the left and right ⇒ *Workshop Manual '50561905 Removing and installing front wheel housing liner (rear part)'*.
- 7 Install front wheel housing liner (front part) at the left and right ⇒ *Workshop Manual '50561901 Removing and installing front wheel housing liner (front part)'*.
- 8 Fit both front wheels ⇒ *Workshop Manual '440519 Removing and installing wheel'*.
- 9 Lower the vehicle and remove it from the lifting platform ⇒ *Workshop Manual '4X00IN Lifting the vehicle'*.
 - 9.1 Lower the vehicle onto the **9453 - access ramps (or similar)** with the lifting platform.
 - 9.2 Remove mounting plates **9002/1 - Lifting platform holders** and install the covers on the underbody ⇒ *Workshop Manual '518119 Removing and installing jacking points'*.



Information

Due to the large number of threaded joints on the chassis to be loosened as part of this campaign, the **wheel alignment** on the front axle must be checked **after replacing the suspension arms**. Given the low setpoint value tolerances of the wheel alignment values and the different wheel alignment systems used in the dealer organization, the wheel alignment positions must therefore be compared with the **wheel alignment values determined beforehand during the initial measurement** and may have to be reset to these values after carrying out the campaign. This ensures optimal adjustment of the wheel alignment positions after replacing the suspension arms.

If individual wheel alignment values are **not within the prescribed adjustment tolerance** during the **initial measurement** as a result of bumping into curbs, the relevant wheel alignment positions must be set to the **wheel alignment values specified in the Workshop Manual**, ⇒ *Workshop Manual '4X00IN Adjustment values for suspension alignment'*. A visual check for damage must also be performed on all relevant chassis components in this case.

- 10 Measure the vehicle height as well as the camber and toe adjustment values on the front axle and adjust them to the values determined beforehand if necessary ⇒ *Workshop Manual '449503 Suspension alignment, complete'*.
To do this, raise the vehicle on a wheel alignment platform.
- 11 Enter the recall campaign in the Warranty and Maintenance booklet.

References:

- ⇒ *Workshop Manual '4X00IN Lifting the vehicle'*
- ⇒ *Workshop Manual '4X00IN Tightening torques for front axle'*
- ⇒ *Workshop Manual '4X00IN Adjustment values for suspension alignment'*
- ⇒ *Workshop Manual '440519 Removing and installing wheel'*
- ⇒ *Workshop Manual '449503 Suspension alignment, complete'*
- ⇒ *Workshop Manual '465119 Removing and installing front PCCB brake disc'*
- ⇒ *Workshop Manual '473919 Removing and installing front brake calliper'*

- ⇒ Workshop Manual '50561901 Removing and installing front wheel housing liner (front part)'
- ⇒ Workshop Manual '50561905 Removing and installing front wheel housing liner (rear part)'
- ⇒ Workshop Manual '518119 Removing and installing jacking points'
- ⇒ Workshop Manual '519219 Removing and installing cover for front underbody'
- ⇒ Workshop Manual '51931900 Removing and installing cover for centre underbody'
- ⇒ Workshop Manual '51931901 Removing and installing cover for centre underbody (at the sides)'

Warranty processing



Information

The working times specified below were determined specifically for carrying out this campaign and may differ from the working times published in the Labor Operation List in PIWIS.

The time required for **measuring the vehicle height as well as the camber and toe adjustment values** on the front axle **before and after carrying out the campaign** is **included** in the working times.

All work that must be carried out in order to **adjust the wheel alignment positions** and parts required during the adjustment process are **not** included in the **scope of this campaign** and must be invoiced using a separate warranty claim.

Attachment "B": **Claim Submission** - Recall Campaign AG09

Warranty claims should be submitted via WWS/PQIS.

Open campaigns may be checked by using either the PIWIS Vehicle Information system or through PQIS Job Creation.

Labor, parts, and sublet will be automatically inserted when Technician is selected in WWS/PQIS. If necessary, the required part numbers will need to be manually entered into warranty system by the dealer administrator.

Information: **This campaign must be carried out by a Service Level 2 Porsche Dealer.**

Service Level 0 or 1 Dealers are NOT authorized to carry out this campaign. In accordance with the service concept for the 918 Spyder, the vehicle must be transferred to a Service Level 2 Dealer in order to carry out this recall. If the vehicle should require transport from your dealership to a Level 2 Dealer and transportation has not previously been arranged by the 918 Client Relationship Team, you should contact Roadside Assistance at 1-844-918-SPYD (7793) to facilitate the transfer.

In this case, Service Level 0 or 1 Porsche Dealers can invoice the cost items listed below for vehicle acceptance, transporting the vehicle and accepting the vehicle following return transport using the **new vehicle warranty** for the vehicle in accordance with the specifications in the 918 Spyder AfterSales Fact Book 2014:

- | | |
|----------------------------|--------|
| • Vehicle acceptance | 100 TU |
| • Transporting the vehicle | 100 TU |

- Acceptance of the vehicle following return transport 50 TU
 - Costs for transporting the vehicle to and from the Porsche Centre Amount as per invoice *
- * Please document copy of invoice in PQIS.

Please invoice the costs by specifying **Damage code C902 97 000** and enter the technical reason by specifying **Coding C9020 9735** in PQIS. Also specify **Campaign AG09** under Comment.

Service Level 2 Porsche Dealers must always submit an invoice for the relevant **campaign scope**.

Scope 1: Replacing lower suspension arms for front axle.

- Vehicles with **Racetrack (Weissach) package (I-no. 808)**

Working time:

Replacing lower trailing arm for front axle at the left and right Labor time: **636 TU**

Includes:

- Raising and lowering the vehicle
- Removing and installing front wheel at the left and right
- Removing and installing front wheel housing liner (front part) at the left and right
- Removing and installing front wheel housing liner (rear part) at the left and right
- Removing and installing cover for center underbody (at the sides)
- Removing and installing cover for front underbody
- Removing and installing cover for center underbody
- Loosening and securing front brake caliper at the left and right
- Removing and installing front PCCB brake disc at the left and right
- Measuring vehicle height as well as camber and toe adjustment values on the front axle (2x)

Parts required:

918 341 053 02	Lower trailing arm for front axle, left/right	2 ea.
000 043 306 64	Set of fastening parts for Racetrack 9Weissach) package, left/right	2 ea.

Required materials:

000 043 302 72	Protective wax Pfinder AP14/4, 100g tube	0.1 ea. (= approx. 10 g)
----------------	--	-----------------------------

000 043 300 35	McLube Sailkote High Performance Dry Lube, 428g spraying can Also commercially available at marine supply stores.	0.05 ea. (= approx. 20 g)
000 043 981 00	Autol Top 2000 grease, 25 ml tube	0.1 ea. (= approx. 2.5 g)

⇒ **Damage Code AG09 099 000 2**

Scope 2: Replace lower suspension arms for front axle.

- Vehicles **without** Racetrack (Weissach) package

Working time:

Replacing lower suspension arm for front axle at the left and right	Labor time: 636 TU
Includes:	
Raising and lowering the vehicle	
Removing and installing front wheel at the left and right	
Removing and installing front wheel housing liner (front part) at the left and right	
Removing and installing front wheel housing liner (rear part) at the left and right	
Removing and installing cover for center underbody (at the sides)	
Removing and installing cover for front underbody	
Removing and installing cover for center underbody	
Loosening and securing front brake caliper at the left and right	
Removing and installing front PCCB brake disc at the left and right	
Measuring vehicle height as well as camber and toe adjustment values on the front axle (2x)	

Parts required:

918 341 053 02	Lower suspension arm for front axle, left/right	2 ea.
000 043 306 63	Set of fastening parts, left/right	2 ea.

Required materials:

000 043 302 72	Protective wax Pfinder AP14/4, 100g tube	0.1 ea. (= approx. 10 g)
000 043 300 35	McLube Sailkote High Performance Dry Lube, 428g spraying can Also commercially available at marine supply stores.	0.05 ea. (= approx. 20 g)

000 043 981 00

Autol Top 2000 grease, 25 ml tube

0.1 ea.
(= approx. 2.5 g)

⇒ Damage Code AG09 099 000 2

Important Notice: Technical Bulletins issued by Porsche Cars North America, Inc. are intended only for use by professional automotive technicians who have attended Porsche service training courses. They are written to inform those technicians of conditions that may occur on some Porsche vehicles, or to provide information that could assist in the proper servicing of a vehicle. Porsche special tools may be necessary in order to perform certain operations identified in these bulletins. Use of tools and procedures other than those Porsche recommends in these bulletins may be detrimental to the safe operation of your vehicle, and may endanger the people working on it. Properly trained Porsche technicians have the equipment, tools, safety instructions, and know-how to do the job properly and safely. If a particular condition is described, do not assume that the bulletin applies to your vehicle, or that your vehicle will have that condition. See your authorized Porsche Dealer for the latest information about whether a particular technical bulletin applies to your vehicle. Part numbers listed in these bulletins are for reference only. Always check with your authorized Porsche dealer to verify the current and correct part numbers. The work procedures updated electronically in the Porsche PIWIS diagnostic and testing device take precedence and, in the event of a discrepancy, the work procedures in the PIWIS Tester are the ones that must be followed.

© Porsche Cars North America, Inc.

Dealership	Service Manager	Shop Foreman	Service Technician
Distribution	Asst. Manager	Warranty Admin.	Service Technician
Routing			

Dr. Ing. h.c. F. Porsche AG is the owner of numerous trademarks, both registered and unregistered, including without limitation the Porsche Crest®, Porsche®, Boxster®, Carrera®, Cayenne®, Cayman®, Macan®, Panamera®, Speedster®, Spyder®, 918 Spyder®, Tiptronic®, VarioCam®, PCM®, PDK®, 911®, RS®, 4S®, FOUR, UNCOMPROMISED®, and the model numbers and the distinctive shapes of the Porsche automobiles such as, the federally registered 911 and Boxster automobiles. The third party trademarks contained herein are the properties of their respective owners. Porsche Cars North America, Inc. believes the specifications to be correct at the time of printing. Specifications, performance standards, standard equipment, options, and other elements shown are subject to change without notice. Some options may be unavailable when a car is built. Some vehicles may be shown with non-U.S. equipment. The information contained herein is for internal authorized Porsche dealer use only and cannot be copied or distributed. Porsche recommends seat belt usage and observance of traffic laws at all times.

Printed in the USA