



Date: December 13, 2016

TECHNICAL SERVICE BULLETIN

Indian Motorcycle

Bulletin Number: I-16-03-AA
Model Years: 2014-2017

Safety Bulletin

Service Bulletin

Service Alert Fax

Distribution: Owner/Principal Service Manager Sales Manager Parts Manager Technicians

This Service Bulletin is located at www.polarisdealers.com
-Confidential and Proprietary-

VERSION: R02 (May 8, 2017)

IMPORTANT STOP SALE SAFETY NOTICE!

STOP SELLING ALL INDIAN MOTORCYCLES IMMEDIATELY UNTIL THE REPAIR PROCEDURE HAS BEEN COMPLETED ON ALL AFFECTED UNITS AT YOUR DEALERSHIP

IMPORTANT

If you are working with a printed copy, please verify you have the most current version of these instructions.

SUBJECT:

2014-2017 Indian Motorcycles (111 ci) – Limiter Bracket Install, Fuel Rail Inspection

PURPOSE:

Indian Motorcycle has identified a concern on 2014-2017 (Chief Classic, Chief Darkhorse, Chief Vintage, Chieftain, Chieftain Darkhorse, Springfield, Roadmaster) models where the fuel rail can contact other components and cause a fuel leak.

Refer to “Unit Inquiry” on the dealer website to ensure each vehicle is within the specified VIN range for this Safety Bulletin. Refer to the repair procedure below for the proper steps to complete this bulletin.

Your service department **MUST** perform the following actions as directed by this Safety Bulletin:

1. Each member of your service department team must review this Safety Bulletin in its entirety.
2. Each member of your service department team must watch the training video prior to ordering **ANY** parts, completing **ANY** work, or submitting **ANY** warranty claim for this Safety Bulletin.

AFFECTED MODELS:

MODEL YEAR	MODELS	VEHICLE IDENTIFICATION NUMBER RANGE
2014	Chief Classic / Chief Vintage / Chieftain	Reference “Unit Inquiry” on the dealer website or the Service Bulletin list on the STOP site to lookup affected units.
2015	Chief Classic / Chief Vintage / Chieftain / Roadmaster	
2016	Chief Classic / Chief Darkhorse / Chief Vintage / Chieftain / Springfield / Roadmaster	
2017	Chief Classic / Chief Darkhorse / Chief Vintage / Chieftain / Chieftain Darkhorse / Roadmaster	

CUSTOMER NOTIFICATION

A customer notification letter will be sent to all registered owners of affected vehicles. In addition to the notification letter sent by Polaris, dealers are required to review sales records and contact consumers who have purchased a potentially affected vehicle. Make arrangements to perform the steps outlined in this Safety Bulletin immediately.

WARRANTY CLAIM / PARTS INFORMATION:

File claim type **SB (Service Bulletin)**.

SERVICE BULLETIN #	I-16-03-AA Limiter Bracket <i>Installation</i> and Fuel Rail <i>Inspection</i>
CLAIM TYPE	SB (Service Bulletin)
LABOR ALLOWANCE	18 Minutes (0.3 Hours)
PART NUMBER / DESCRIPTION	2207173 (QTY.1) KIT, BRACKET 7170107 (QTY.1) BULLETIN COMPLETION DECAL
PARTS AVAILABILITY	Available to Order
UNIVERSITY OF POLARIS VIDEO TRAINING REQUIREMENT	YES*
PHOTO SUBMISSION REQUIRED	NO**

*Polaris requires one person from a dealership to be certified before parts ordering may occur and two people from a dealership to be certified before warranty claims may be processed.

**Photo submission is NOT required for warranty claims. If fuel rail replacement is required, take a picture of the fuel rail and retain a copy for checkback audit.

SERVICE BULLETIN #	I-16-03-AB Limiter Bracket <i>Installation</i> and Fuel Rail <i>Installation</i>
CLAIM TYPE	SB (Service Bulletin)
LABOR ALLOWANCE	60 Minutes (1.0 Hours)
PART NUMBER / DESCRIPTION	2207173 (QTY.1) KIT, BRACKET 2521800 (QTY.1) FUEL RAIL 1500198 (QTY.2) O-RING, INJECTOR, UPPER 5412891 (QTY.2) O-RING, INJECTOR, LOWER 7170107 (QTY.1) BULLETIN COMPLETION DECAL
PARTS AVAILABILITY	Available to Order
UNIVERSITY OF POLARIS VIDEO TRAINING REQUIREMENT	YES*
PHOTO SUBMISSION REQUIRED	NO**

*Polaris requires one person from a dealership to be certified before parts ordering may occur and two people from a dealership to be certified before warranty claims may be processed.

**Photo submission is NOT required for warranty claims. If fuel rail replacement is required, take a picture of the fuel rail and retain a copy for checkback audit.

NOTE

Polaris requires dealers to maintain warranty records, including repair orders and supporting documentation for five years. All claims for additional labor, dealer transport/travel or part stock claims for I-16-03 are subject to audit and inspection. Infractions will result in chargebacks and fines in accordance with the Polaris Audit Policy.

SAFETY BULLETIN CONTACT LIST & SCHEDULING TOOL

A new scheduling tool is available for dealers to keep a record of customers contacted and scheduled for bulletin repairs. This optional tool provides visibility for your dealership and will be helpful to track the status of scheduled service. For more information log in to www.universityofpolaris.com

SPECIAL TOOLS

- **US and Canada Dealers:** The special tools outlined in this bulletin have been direct-shipped to dealers at no-cost starting the week of December 12, 2016.
- **International Dealers:** The special tools outlined in this bulletin must be ordered through normal Polaris service parts channels. File a Part Stock warranty claim for tool reimbursement.

NOTE: Special tools will become available in limited quantities the week of December 12, 2016. Please limit orders to one set of tools per dealership/distributorship.

WARRANTY COVERAGE PERIOD

Warranty coverage for Safety Bulletin I-16-03-AA/AB will begin December 13, 2016. This bulletin has no expiration date.

DISPOSAL INFORMATION

Dealers/Distributors: Under no circumstances shall the parts removed in this repair be re-used, sold, or re-purposed for another application. It is your dealership / distributor's responsibility to make sure every part replaced (related to this bulletin) is taken out of circulation and disposed of properly.

SERVICE BULLETIN COMPLETION DECAL

A Service Bulletin Completion Decal must be completed for this bulletin repair. Remove the inside left cover and place the decal on inside of the cover. If you require more decals, order them through normal Polaris parts ordering channels.

Sincerely,



Doug Koch
Technical Service and Warranty Director

IMPORTANT

Several steps of this procedure require an audit by another dealership representative other than the technician who is completing the repair. Completing these check backs is a critical component to ensuring the repair has been properly completed. An audit checklist will be provided with each kit. It must be completed and retained with the instruction sign-off and repair order.

AUDIT CHECKLIST:

- Verify that the coil ground wire is not touching the cylinder cooling fins.
- The Limiter Bracket must have an airgap between damper and limiter bracket "shelf". With bracket fully installed and tightened, make sure there is clearance between the bottom of the damper and limiter bracket.
- Verify the limiter bracket to damper body measurement is within specification. Mark the bracket with a paint pen.
Measurement: **0 mm – 21 mm**
- Verify the Fuel Line Connector does not contact the bottom of the fuel tank.
- Inspect the fuel rail and check for signs of abrasion and fuel leak. If fuel rail replacement is required, take a picture of the fuel rail and retain a copy for checkback audit.
- Verify the Horn Bracket Fastener has been torqued using a torque wrench set to the correct specification. Mark the fastener with a paint pen. Torque value: **84 in-lbs (10 Nm)**
- Pressurize the fuel system by powering up the bike and slide the STOP/RUN switch to the RUN position. Verify no leaks present with system under pressure.

* IF FUEL RAIL REPLACEMENT IS REQUIRED, COMPLETE THE ADDITIONAL CHECKLIST ITEMS

- Verify the Fuel Rail Fasteners have been torqued using the special torque tool with a torque wrench set to the correct specification. Mark the fasteners with a paint pen. Torque value using the special torque tool: **74 in-lbs (9 Nm)**
- During reassembly, verify that no obstructions are present in the intake.
- During reassembly, verify that both fuel tank isolators are assembled correctly.
- Connect the motorcycle to Digital Wrench. Verify no fail codes and no MIL lights are present.

UNIVERSITY OF POLARIS VIDEO TRAINING REQUIREMENT

Each member of your service department team must watch the training video on University of Polaris prior to completing any work, or submitting ANY warranty claim for this Safety Bulletin. You must watch the video through the University of Polaris in order to get credit for watching the video.

www.universityofpolaris.com

FEEDBACK FORM

A feedback form has been created for the technician to provide POLARIS with an overall satisfaction rating for the instructions, provide comments on your experience or upload pictures/videos from a specific repair. This feedback form is viewable on a mobile device by scanning the QR code shown or by clicking [HERE](#) if viewing this document electronically.

FEEDBACK FORM



PARTS LIST

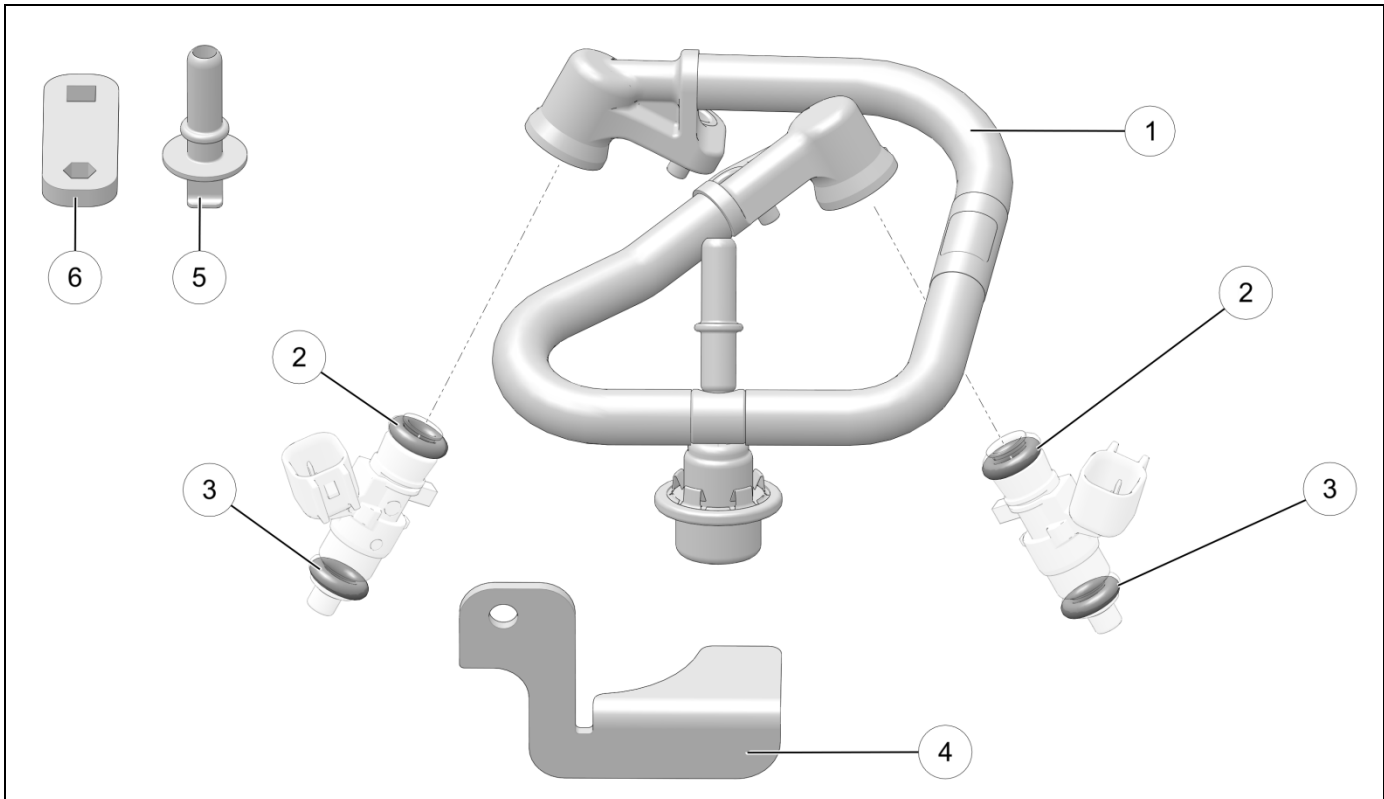

REF	PART DESCRIPTION	PART NUMBER	QTY
①	FUEL RAIL	2521800	1
②	O-RING, INJECTOR, UPPER	1500198	2
③	O-RING, INJECTOR, LOWER	5412891	2
④	KIT, BRACKET	2207173	1
⑤	FUEL LINE PLUG TOOL	2521832	1
⑥	FUEL RAIL TORQUE TOOL	5264374	1

LIMITER BRACKET INSTALL AND FUEL RAIL INSPECTION PROCEDURE:

Tools Required:

- 10 mm socket
- Ratchet
- 3 inch extension
- 5 mm allen wrench
- Digital Caliper
- Torque wrench

Park motorcycle on a lift table with wheel clamped in wheel vise, turn ignition OFF.

CAUTION

Allow engine and exhaust to cool completely before servicing. Failure to follow this warning can result in personal injury.

LIMITER BRACKET INSTALLATION

1. On the right-hand side of the motorcycle, remove three 5 mm allen fasteners ① securing the horn cover.

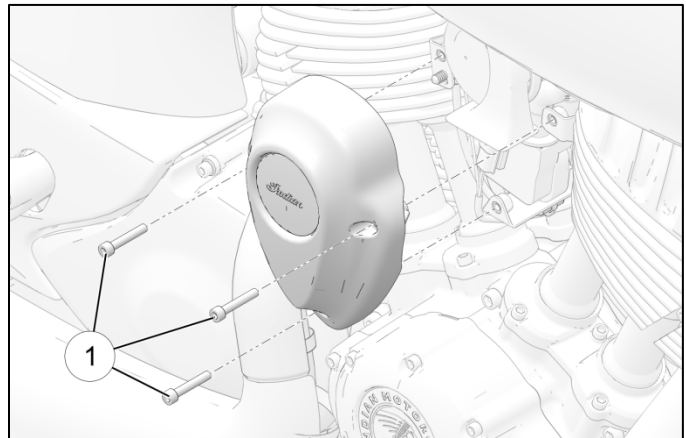

2. Disconnect the electrical connection from the horn connector ②.

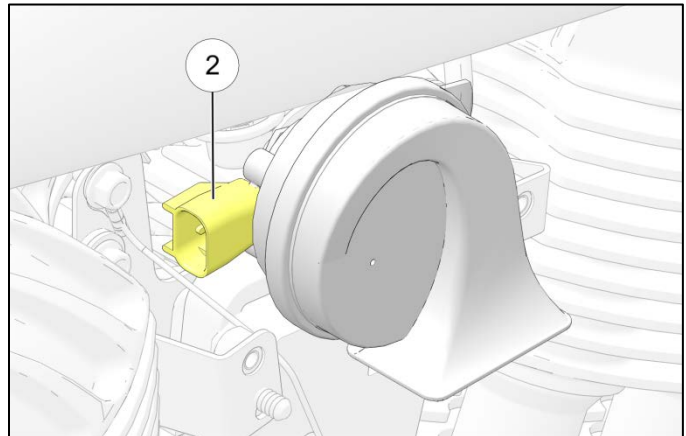

3. Using a 10 mm socket, remove the fastener ③ securing the horn to the ignition coil bracket. Remove the horn.



4. Using a 10 mm socket, remove the ground screw ④.

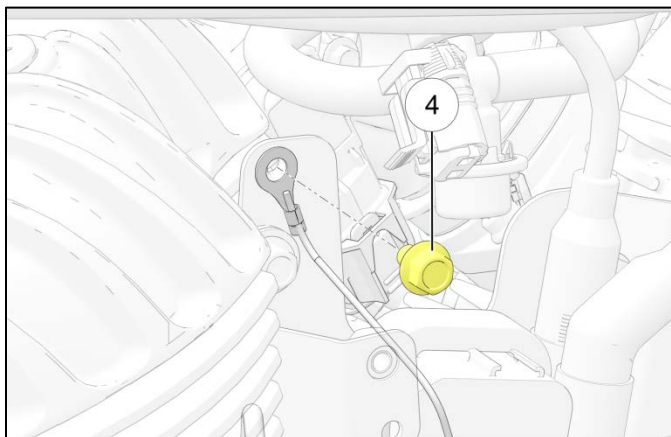

5. Position limiter bracket ⑤ in a horizontal position. Install ground screw ④ and coil ground wire terminal through bracket as shown. Torque to specification.

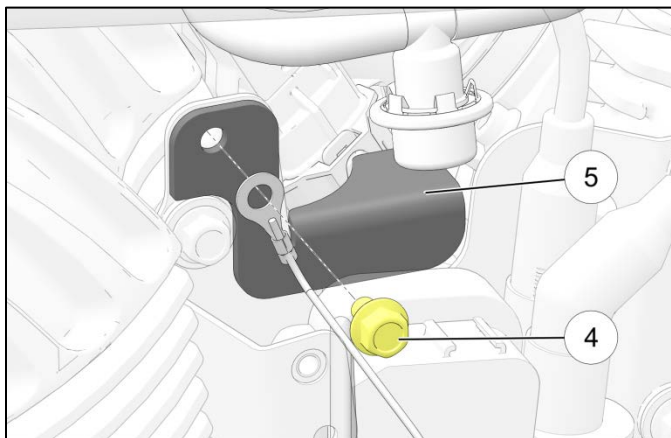

TORQUE

Ground Screw:
84 in-lbs (10 Nm)

IMPORTANT – AUDIT STEP

Verify that the coil ground wire is not touching the cylinder cooling fins.

NOTE

When torquing is complete, verify limiter bracket is aligned in the horizontal position and ground wire is routed as shown.

IMPORTANT – AUDIT STEP

The Limiter Bracket must have an airgap between damper and limiter bracket “shelf”. With bracket fully installed and tightened, make sure there is clearance between the bottom of the damper and limiter bracket.

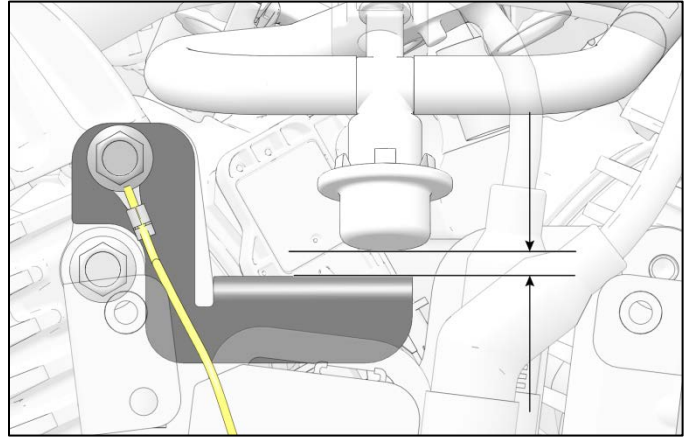

IMPORTANT

Inspect Fuel Rail (6), Breather Hose (7), and Fuel Line (8) to make sure all lines are parallel and routed as shown.

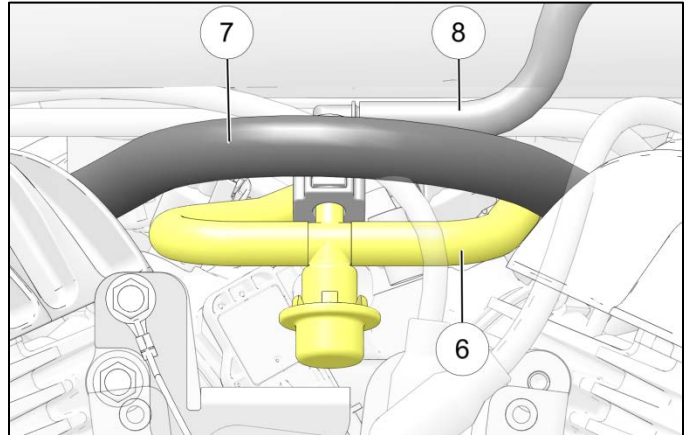

IMPORTANT

Inspect Fuel Line Connector (8) and make sure it does NOT contact the bottom of the fuel tank.

CRITICAL

If the Fuel Line Connector contacts the bottom of the fuel tank, proceed to FUEL RAIL REPLACEMENT on I-16-03-AB of this bulletin.

IMPORTANT – AUDIT STEP

A secondary dealer representative must verify the Fuel Line Connector does not contact the bottom of the fuel tank.

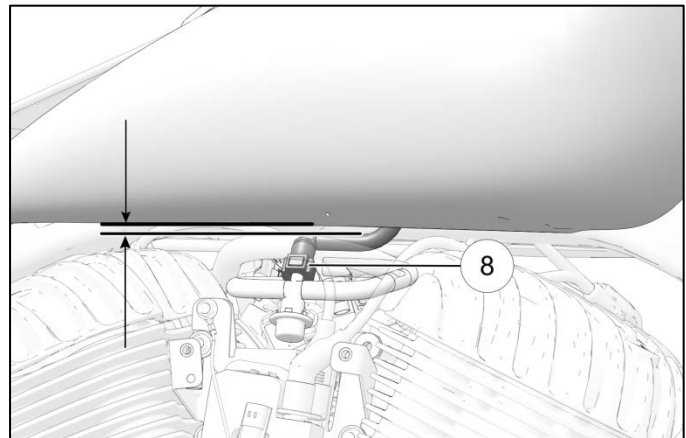

6. Use a ruler to measure the distance between the damper body (9) and face of the limiter bracket (10) as shown.

MEASUREMENT

Limiter Bracket to Damper Body:
0 mm – 21 mm

CRITICAL

If measurement is outside range, proceed to FUEL RAIL REPLACEMENT on **I-16-03-AB** of this bulletin.

IMPORTANT – AUDIT STEP

A secondary dealer representative must verify the limiter bracket to damper body measurement is within specification. Mark the bracket with a paint pen to indicate the audit has been completed.

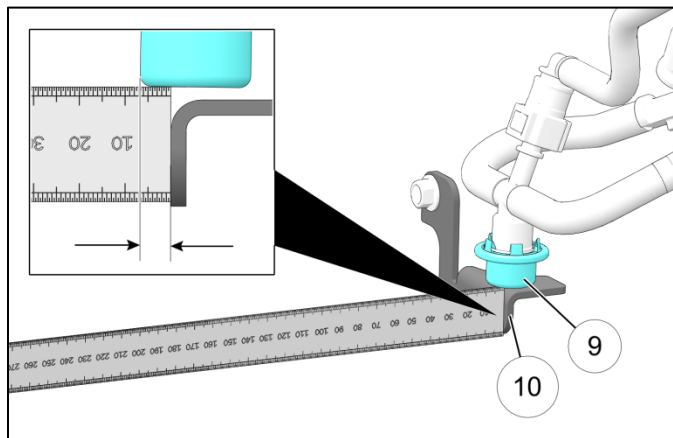

FUEL RAIL INSPECTION

- Inspect the entire fuel rail for cracking or signs of abrasion.
- Inspect the bottom side of the fuel rail for signs of abrasion from contact with the cylinder cooling fins.
- Inspect all four connection joints for any signs of fuel leaks.

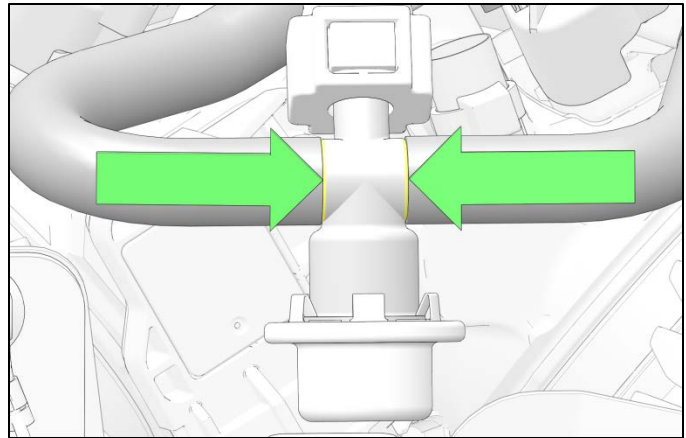
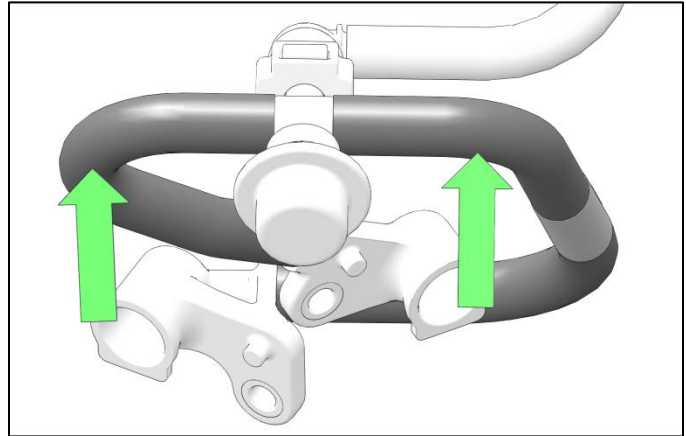

CRITICAL



If signs of abrasion or fuel leaks are found, proceed to **FUEL RAIL REPLACEMENT** on **I-16-03-AB** of this bulletin.

If no abrasion or fuel leaks are present, finish **LIMITER BRACKET INSTALLATION I-16-03-AA** steps to install the horn and horn cover.

IMPORTANT – AUDIT STEP

A secondary dealer representative must inspect the fuel rail and check for signs of abrasion and fuel leak. If fuel rail replacement is required, take a picture of the fuel rail and retain a copy for checkback audit.

I-16-03-AA - LIMITER BRACKET INSTALLATION (CONTINUED)

7. Using a 10 mm socket, install the fastener ③ securing the horn to the ignition coil bracket. Torque to specification.

TORQUE

Horn to Bracket fastener:
84 in-lbs (10 Nm)

IMPORTANT

After tightening, make sure that the bottom of the horn trumpet remains parallel to the ground.

IMPORTANT – AUDIT STEP

A secondary dealer representative must verify the fastener has been torqued using a torque wrench set to the correct specification. Mark the fastener with a paint pen to indicate the audit has been completed.

8. Connect the electrical connection to the horn connector ②.

NOTE

Listen for an audible “click” to confirm the connection is fully engaged.

9. Install Horn Cover using three fasteners ①. Torque fasteners to specification.

TORQUE

Horn Cover fasteners:
84 in-lbs (10 Nm)

10. Field test the motorcycle before putting into service to verify proper operation and verify no indicator lights are present.

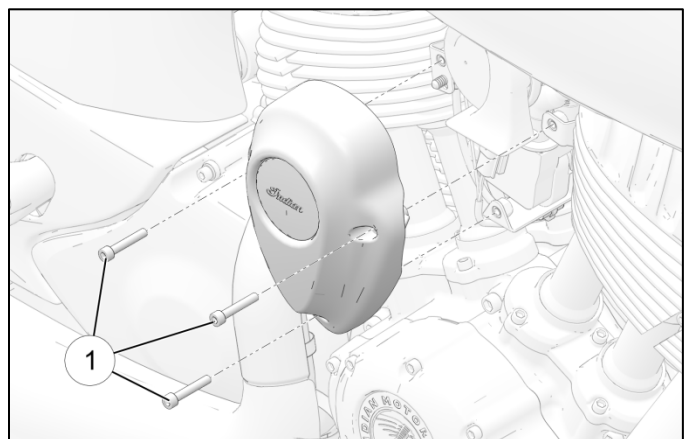
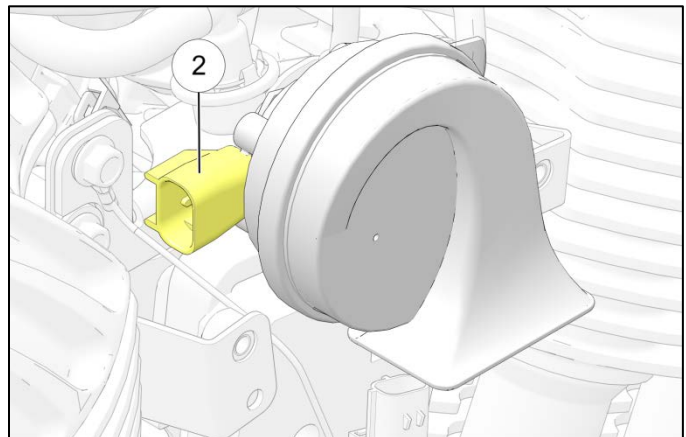
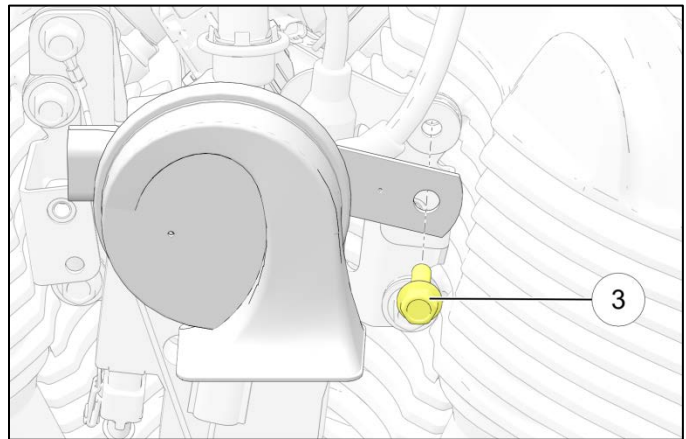

IMPORTANT – AUDIT STEP

A secondary dealer representative must pressurize the fuel system by powering up the bike and slide the STOP/RUN switch to the RUN position. Verify no leaks present with system under pressure

11. File a warranty claim for I-16-03-AA and install a completed Service Bulletin Completion Decal (7170107).

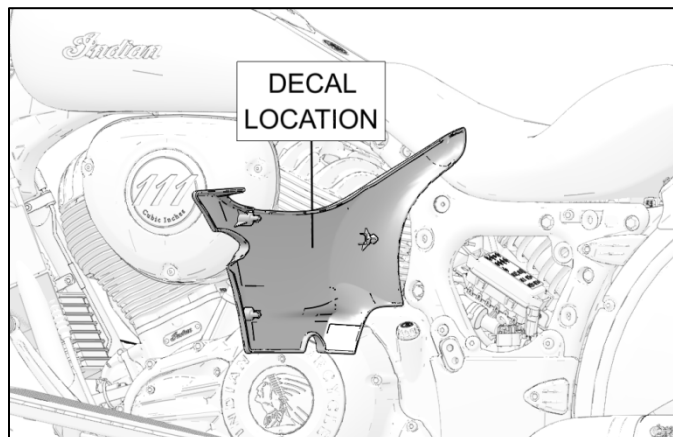

I-16-03-AB - FUEL RAIL REPLACEMENT PROCEDURE:

Tools Required:

- 6 mm, 8 mm, 10 mm socket
- T25 Torx wrench
- Ratchet
- 4 mm, 6 mm allen wrench
- 5 mm allen bit
- Needle Nose Pliers
- Torque wrench
- Fuel Rail Plug Tool 2521832
- Fuel Rail Torque Tool 5264374

REMOVAL

1. Remove Trunk (If equipped).

- a) Remove trunk lock fasteners ① from both the left and right trunk latch.

NOTE

Remove saddlebags if applicable.

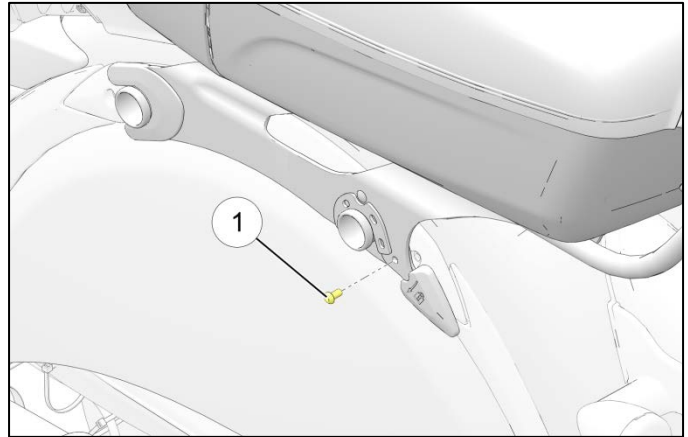

- b) Disconnect the trunk harness multi-plug ②.

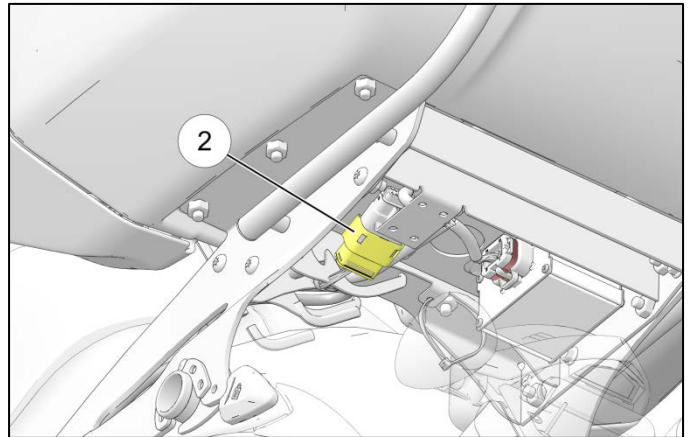

- c) Lift the trunk latches ③ to unlock the trunk from the mount.

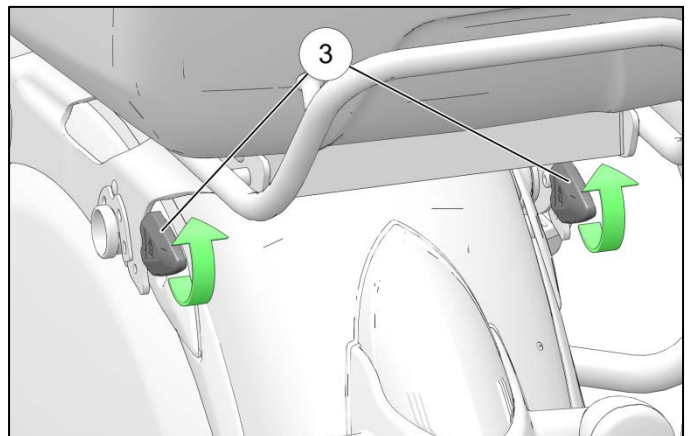

- d) Lift up on the rear of the trunk ④ and slide rearward ⑤ to release the trunk from the motorcycle.

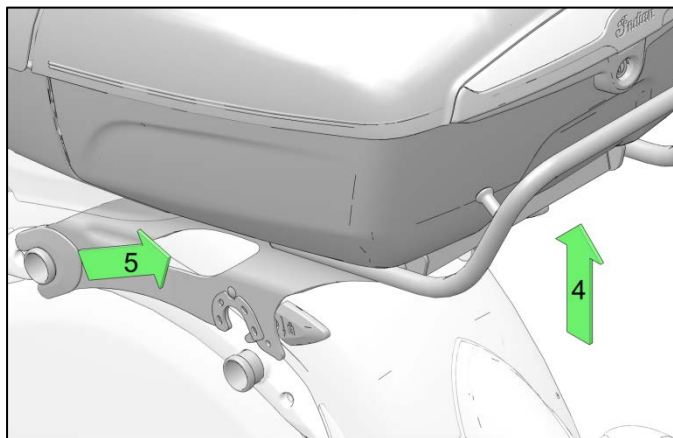

2. Remove upper side covers.

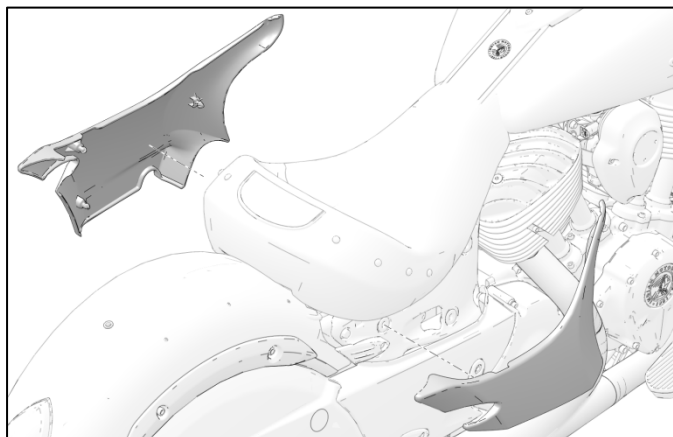

3. Using a 6 mm allen wrench, remove the two fasteners ⑥ retaining the driver seat to the frame. Remove Seat.

NOTE

For models with a passenger seat, remove passenger seat fastener.

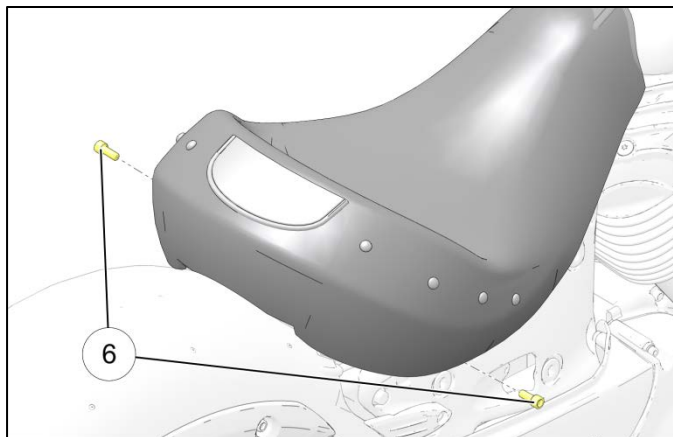

4. Using a 6 mm allen wrench, remove fuel tank fasteners ⑦.

NOTE

To provide access to fuel rail, lift the rear of the fuel tank high enough to insert a small 2x4 piece of wood beneath the fuel tank rear mount.

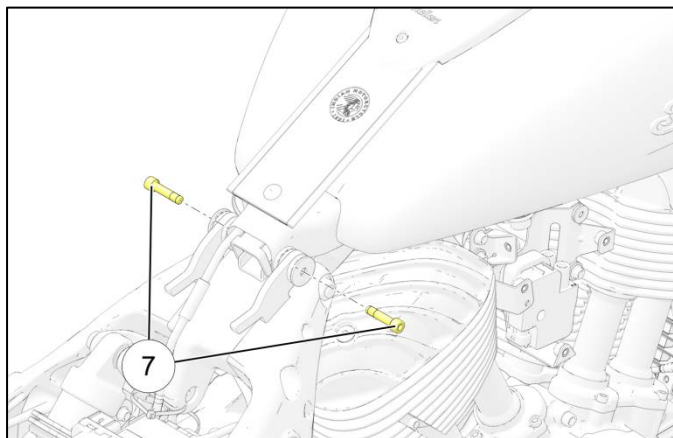

5. Using compressed air, blow any debris away from base of fuel injectors.

CAUTION

Always wear eye protection

NOTE

Cleaning the area with compressed air prevents sand, grit, and dirt from entering the intake runner as the injector is removed.

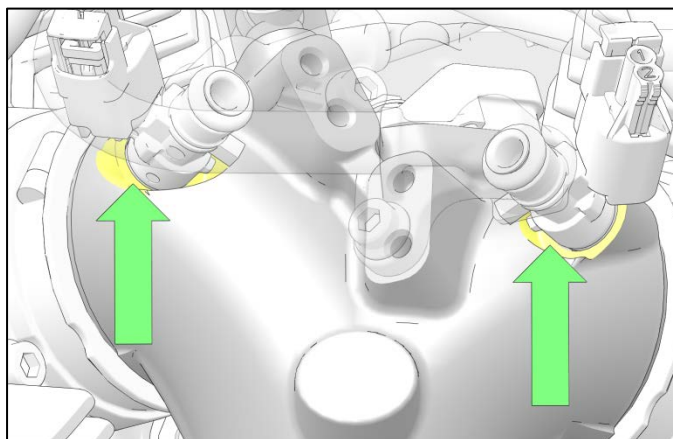

6. Using a 4 mm allen wrench, remove the three fasteners ⑧ securing the air cleaner cover to the air box.

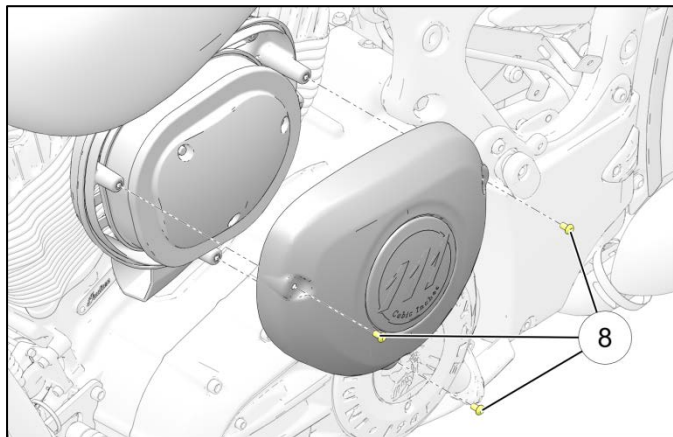

7. Using a 8 mm socket, remove the three fasteners ⑨ securing the air filter to the adapter plate and remove air filter.

NOTE

Accessory intakes may require a different removal process.

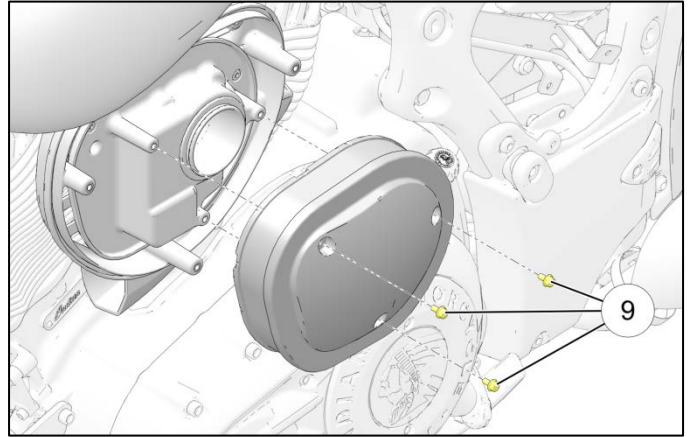

8. Using a T25 Torx wrench, remove the three fasteners ⑩ securing the air filter adapter plate to the air box assembly and remove adapter plate.

NOTE

When removing the adapter plate, start by applying more pressure to the forward (left-hand) edge and pull outward to release the valve cover vent hose from the back side of the adapter plate.

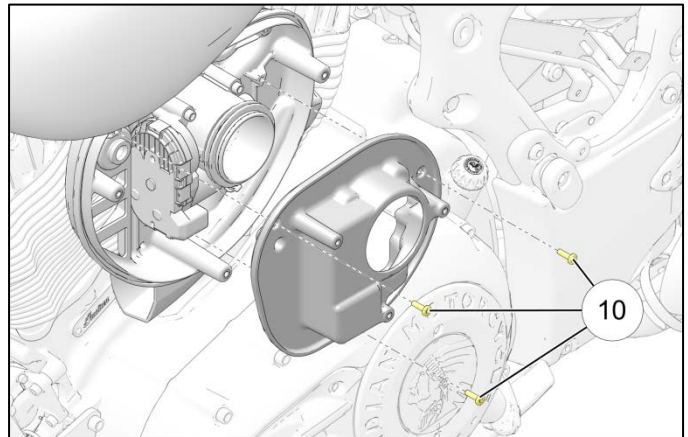

9. Using a 10 mm socket, remove the upper two fasteners ⑪ securing the baffle plate to the intake.

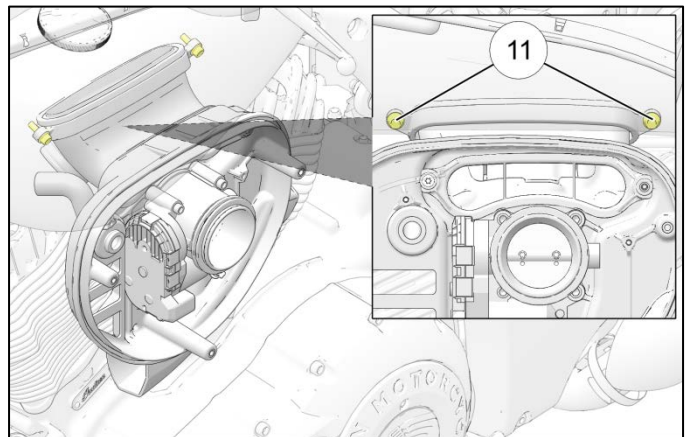

10. Using a 8 mm socket, remove the lower fastener ⑫ securing the air box housing to the mounting plate.

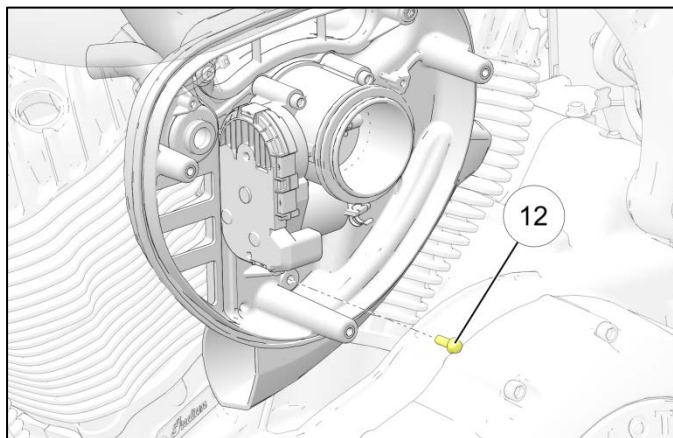

11. Disconnect the multi-plug ⑬ from the throttle body.

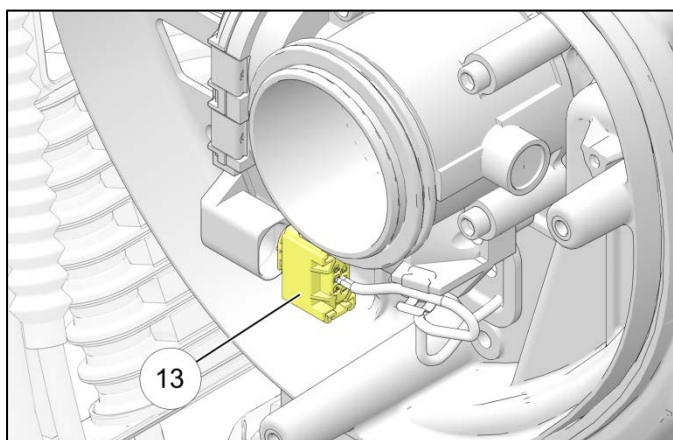

12. Using a 5 mm allen wrench, remove four throttle body fasteners ⑭ and remove throttle body.

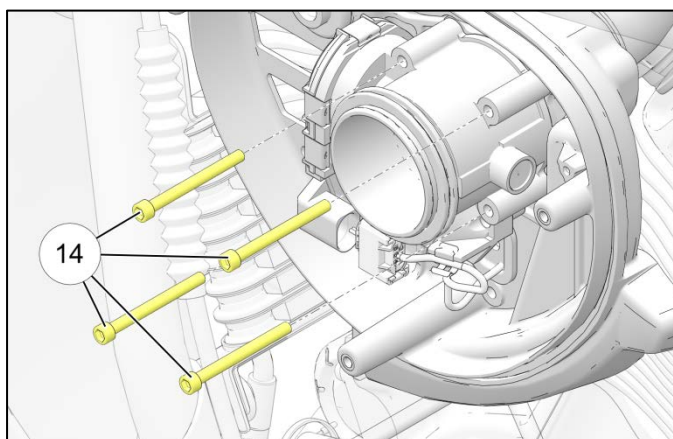

13. Push the rubber multi-plug seal through the back of the air box housing. Disconnect intake hose and remove air box housing.

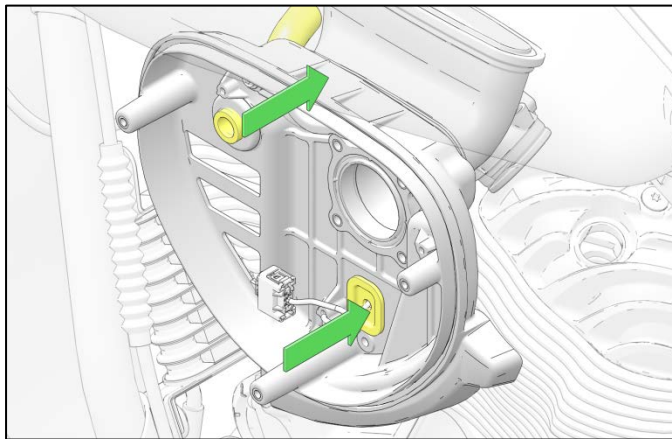

14. Cover intake (15) to prevent debris from entering the engine.

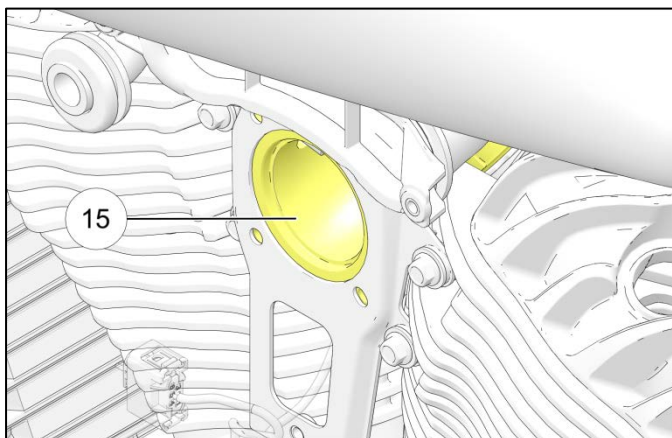

15. Wrap a clean shop towel around fuel line fitting.

16. Squeeze the quick connect buttons (one on each side) and hold. Gently slide fitting straight off the fuel rail.

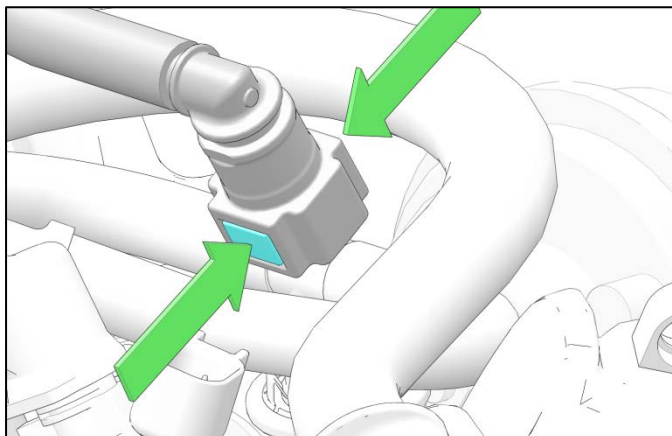

CAUTION

Always wear eye protection

17. Insert FUEL LINE PLUG TOOL (2521832) into fuel line to prevent fuel from leaking.

NOTE

Listen for an audible “click” to confirm the Fuel Line Plug Tool is fully engaged.

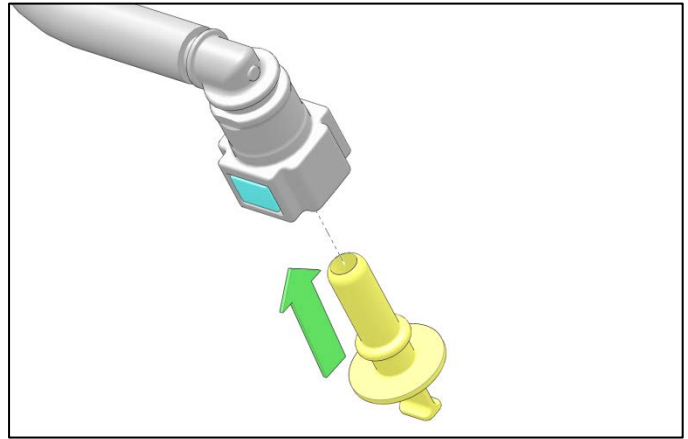

18. Using a 5 mm 'L' shaped allen wrench remove the two fasteners ⑰ securing the fuel rail to the intake manifold. Carefully remove fuel rail from the right-hand side of the motorcycle.

NOTE

When removing fuel rail from injectors, wrap a rag around both ends of the fuel rail to collect fuel.

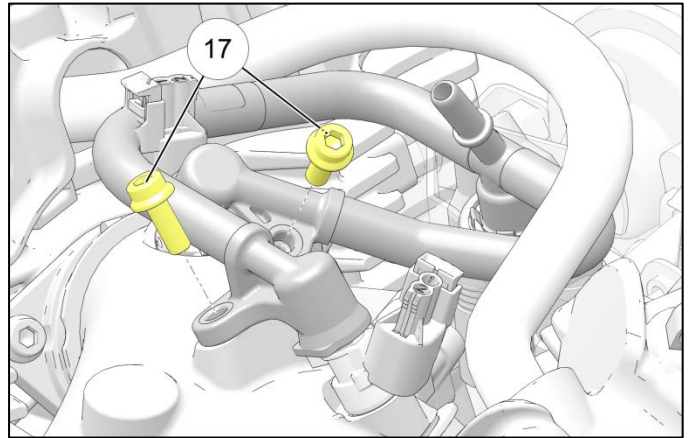

19. Leave electrical connector in place, remove fuel injectors from intake.

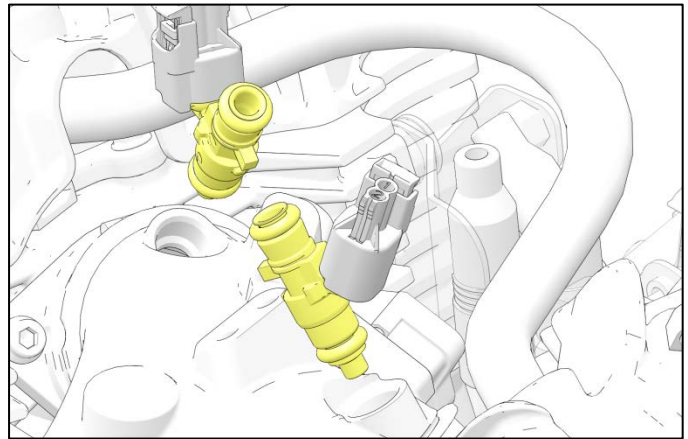

20. Remove o-rings from the top and bottom of the injectors and discard o-rings.

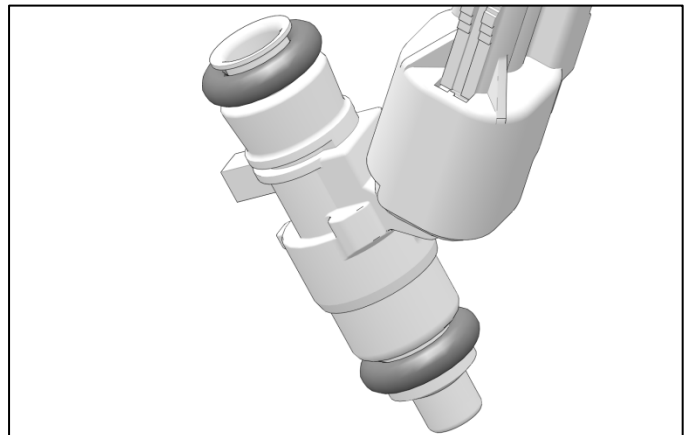

INSTALLATION

1. Lubricate NEW injector o-rings with clean, silicone-free motor oil.

NOTE

Apply oil sparingly and avoid contaminating the pintle valve / jet surface and upper inlet port.

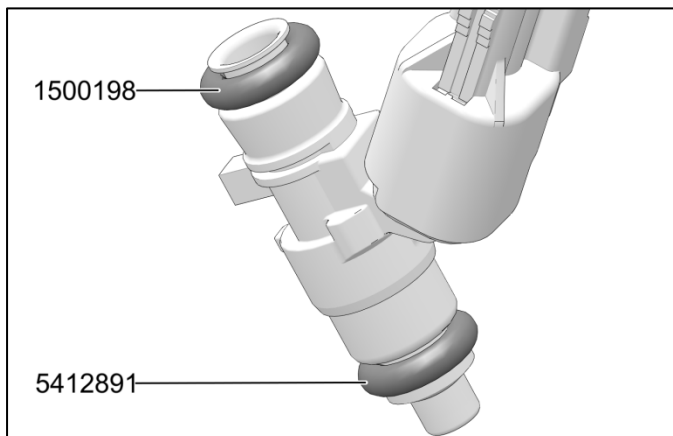

2. Install replacement o-rings onto top and bottom of injectors.

IMPORTANT

Verify that the new top and bottom o-rings are installed in the correct position.

PART	POSITION
1500198	TOP OF INJECTOR
5412891	BOTTOM OF INJECTOR

IMPORTANT

Verify that both of the new o-rings have been lubricated and installed correctly onto the injectors.

3. Install fuel injectors by carefully pressing into intake manifold.

CAUTION

Use care not to fold or displace lower o-ring from seating surface.

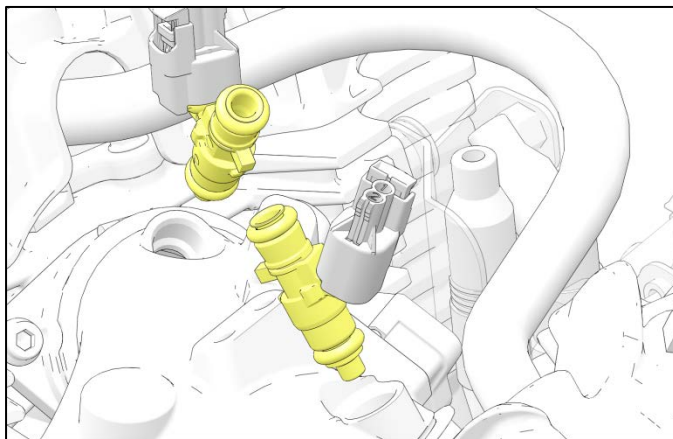

4. Install replacement fuel rail from the right-hand side of motorcycle.

CAUTION

Use care not to fold or displace upper o-ring from seating surface.

5. Install fuel rail fasteners ⑰ into the intake manifold until finger tight.

NOTE

For ease of installation, install the front cylinder fuel rail fastener first.

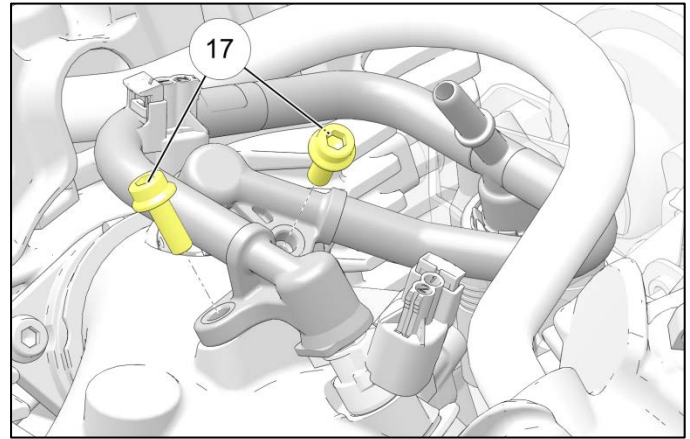

6. Install the FUEL RAIL TORQUE TOOL (5264374) onto a ¼ in drive torque wrench. Install a 5 mm allen bit to the hex end of the torque tool as shown.

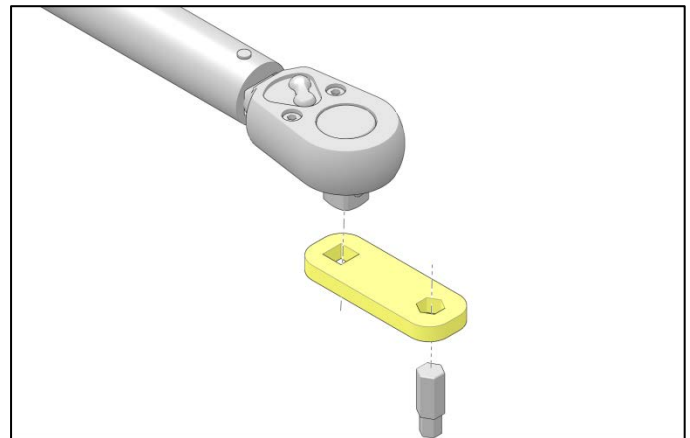

CRITICAL

Alignment of the special tool is critical to achieve the correct torque. Make sure the FUEL RAIL TORQUE TOOL remains in-line with the torque wrench while torquing fasteners.

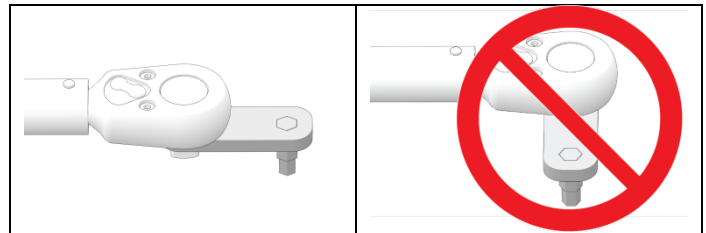

7. Torque fuel rail fasteners to specification.

IMPORTANT

Make sure the FUEL RAIL TORQUE TOOL and the torque wrench remain in-line while torquing fasteners.

TORQUE (USING TORQUE TOOL)

Fuel Rail Fasteners:
74 in-lbs (9 Nm)

IMPORTANT – AUDIT STEP

A secondary dealer representative must verify the Fuel Rail fasteners have been torqued using the special torque tool with a torque wrench set to the correct specification. Mark the fasteners with a paint pen to indicate the audit has been completed.

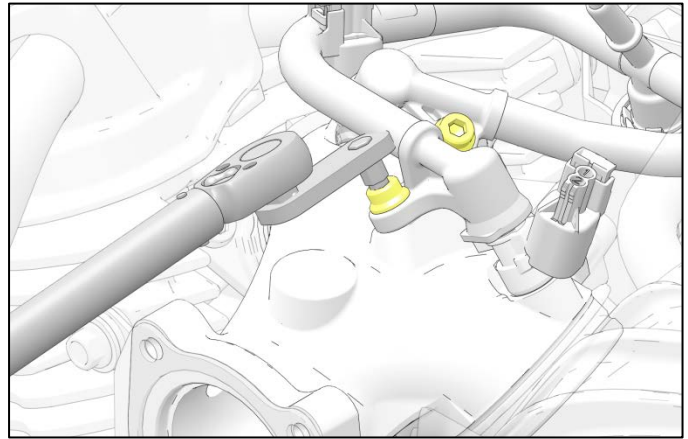

8. Squeeze the quick connect buttons (one on each side) and hold. Remove special tool from fuel line.

NOTE

Use a rag to contain the small amount of fuel that may drain from the fuel line after the special tool is removed.

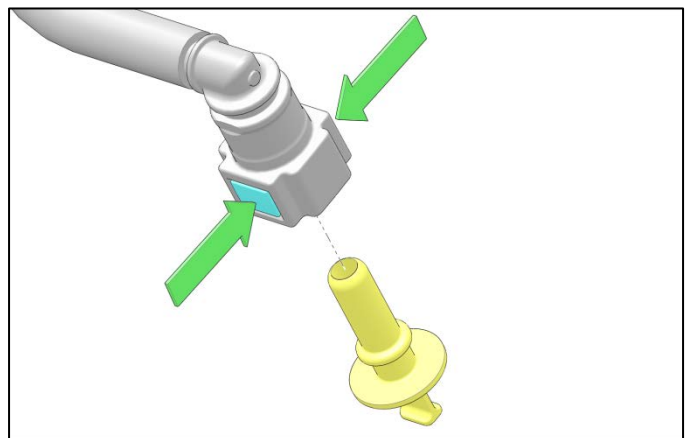

9. Connect fuel line to fuel rail.

NOTE

Listen for an audible “click” to confirm the line is fully engaged.

IMPORTANT

Pressurize the fuel system by powering up the bike and slide the STOP/RUN switch to the RUN position. Verify no leaks present with system under pressure.

IMPORTANT – AUDIT STEP

A secondary dealer representative must pressurize the fuel system by powering up the bike and slide the STOP/RUN switch to the RUN position. Verify no leaks present with system under pressure.

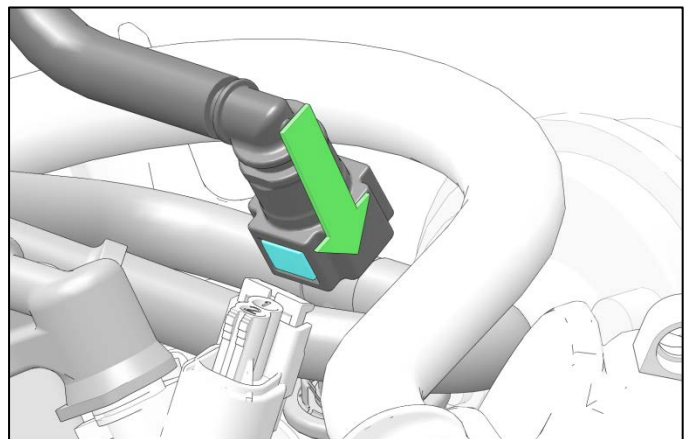

10. Uncover the Intake ⑮.

IMPORTANT – AUDIT STEP

A secondary dealer representative must verify that no obstructions are present in the intake.

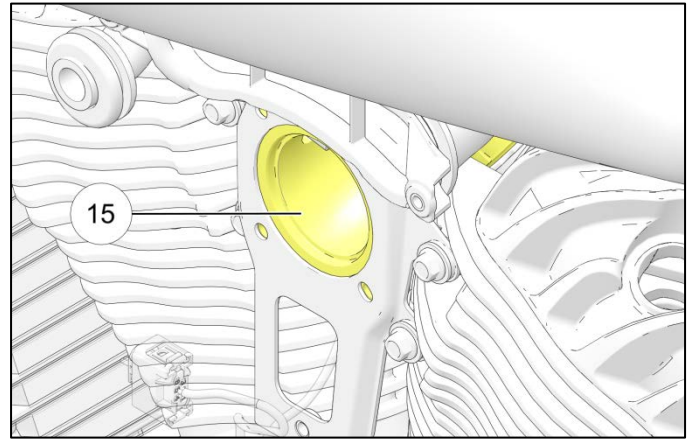

IMPORTANT

Verify that BOTH air box o-ring seals are correctly in position before installing the throttle body.

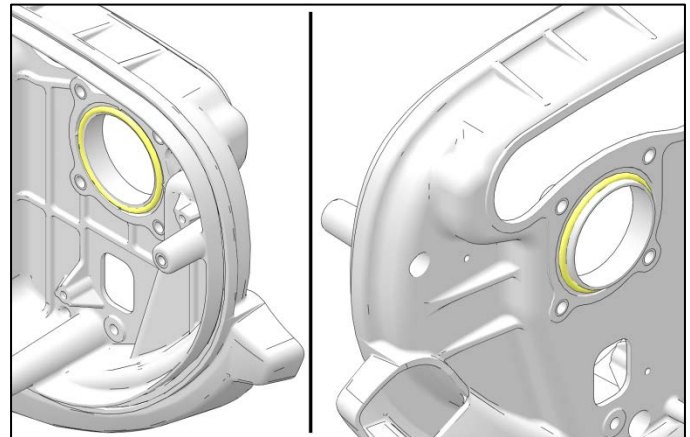

11. Feed the throttle body multi-plug connector through the hole in the air box. Connect intake hose to the air box housing.

NOTE

Use a small amount of lubricant around the outside of the breather hose when installing to the air box housing.

NOTE

Make sure that the harness seal is fully seated in the air box cutout.

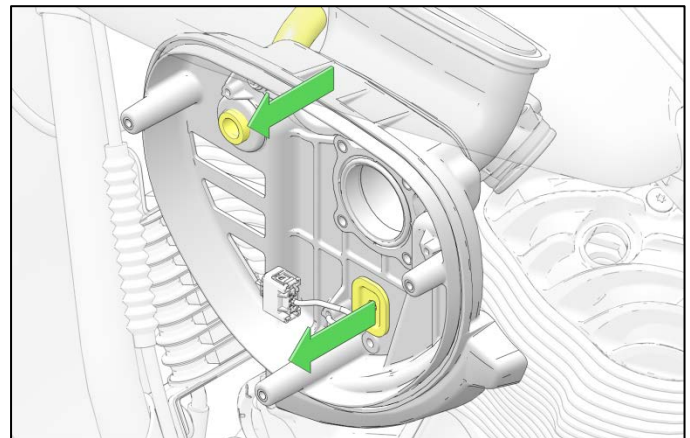

12. Using a 5 mm allen wrench, install four throttle body fasteners ⑭. Torque fasteners to specification.

TORQUE

Throttle Body Fasteners:
84 in-lbs (10 Nm)

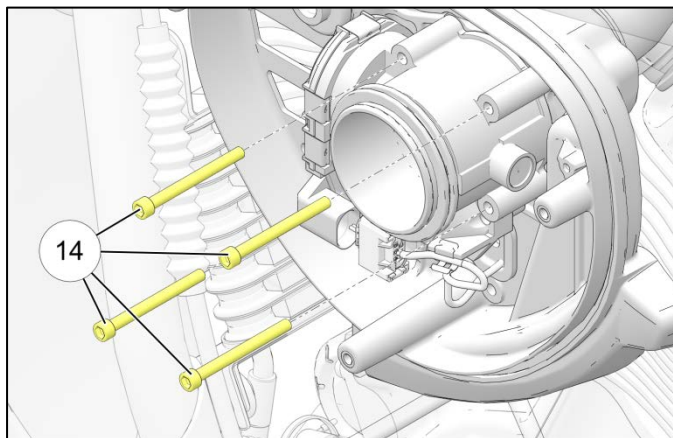

13. Connect the multi-plug ⑬ to the throttle body.

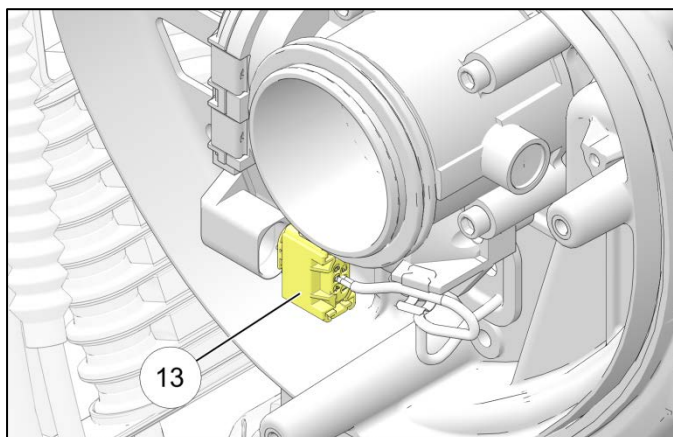

14. Using a 8 mm socket, install the lower fastener ⑫ securing the air box to the mounting plate. Torque fastener to specification.

TORQUE

Air Box Fastener:
84 in-lbs (10 Nm)

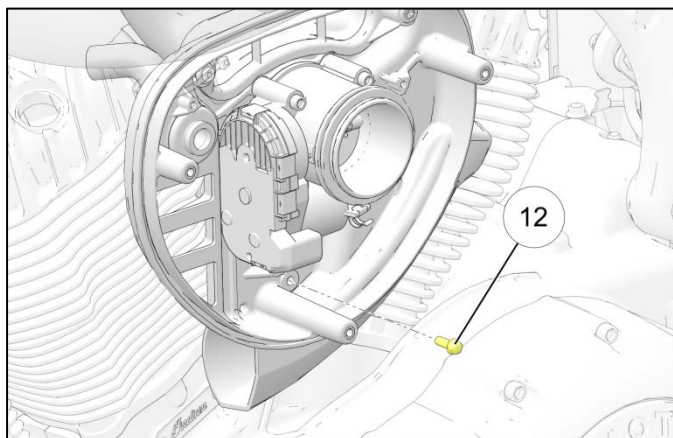

15. Using a 10 mm socket, install the upper two fasteners ⑪ securing the baffle plate to the intake. Torque fasteners to specification.

TORQUE

Upper Intake Fasteners:
84 in-lbs (10 Nm)

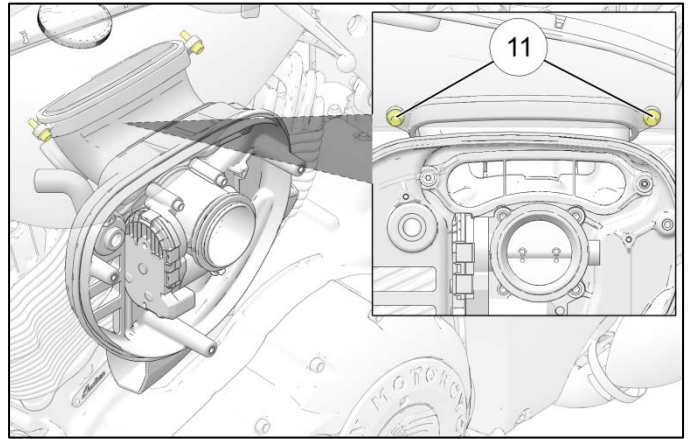

16. Install the three air filter adapter plate fasteners ⑩. Torque fasteners to specification.

TORQUE

Air Filter Adapter Plate Fasteners:
31 in-lbs (4 Nm)

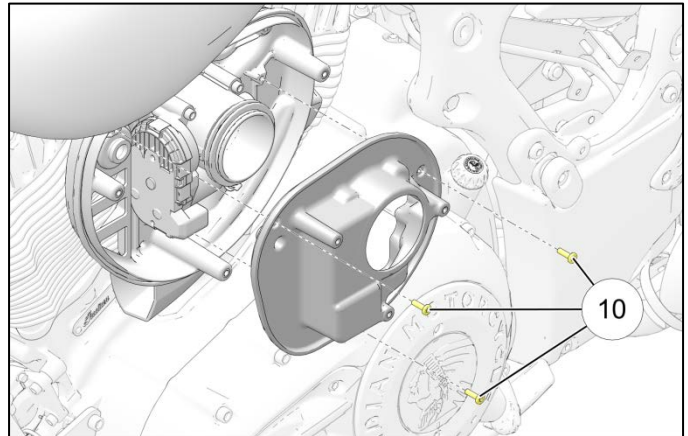

17. Using a 8 mm socket, install the three fasteners ⑨ securing the air filter to the adapter plate. Torque fasteners to specification.

TORQUE

Air Filter Fasteners:
62 in-lbs (7 Nm)

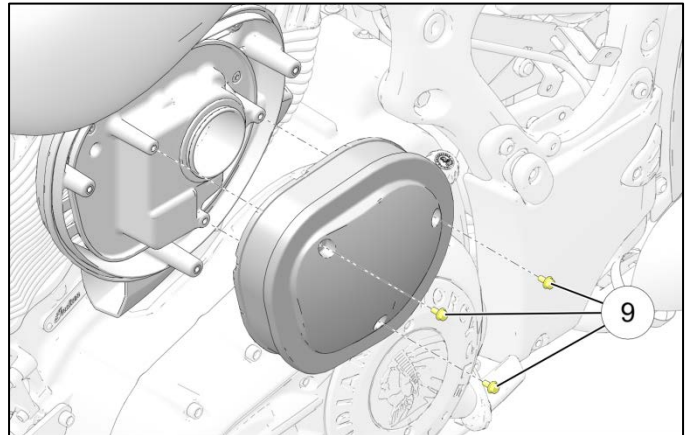

18. Using a 4 mm allen wrench, install the three fasteners ⑧ securing the air cleaner cover to the air box. Torque fasteners to specification.

TORQUE

Air Box Cover Fasteners:
84 in-lbs (10 Nm)

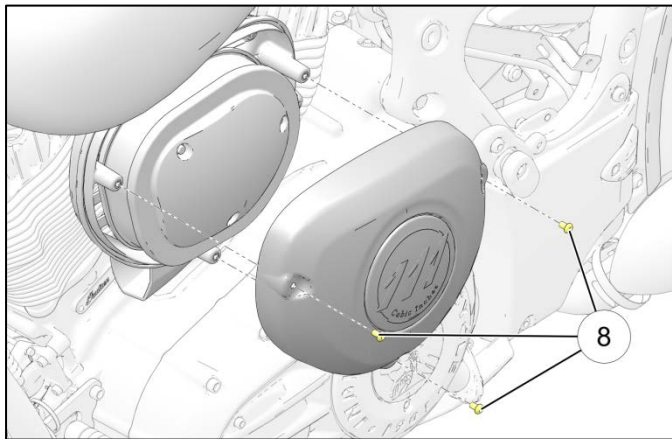

19. Verify that both fuel tank isolators are assembled correctly as shown.

IMPORTANT – AUDIT STEP

A secondary dealer representative must verify that both fuel tank isolators are assembled correctly.

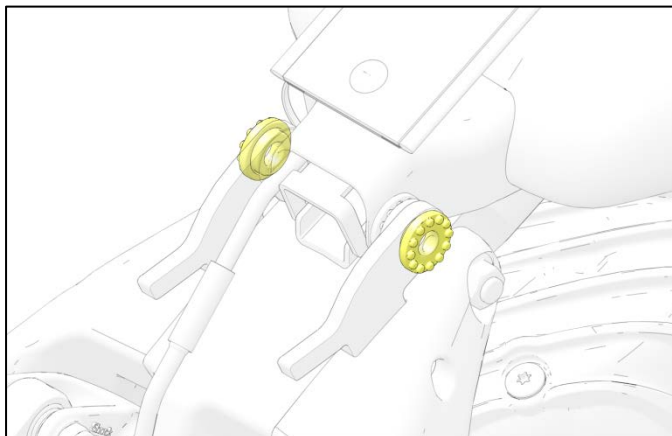

20. Remove the small 2x4 piece of wood beneath the fuel tank rear mount and lower fuel tank into position. Using an 6 mm allen wrench, install fuel tank fasteners ⑦. Torque fasteners to specification.

TORQUE

Fuel Tank Fasteners:
18 ft-lbs (24 Nm)

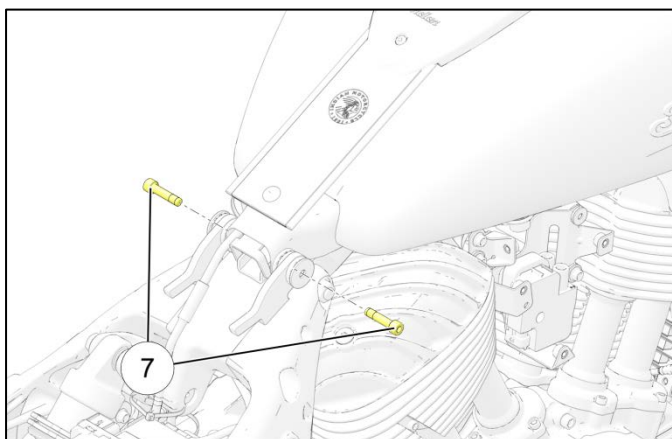

21. Slide front of seat into seat retaining bracket. Using an 6 mm allen wrench, install the two fasteners ⑥ retaining the driver seat to the frame. Torque seat fasteners to specification

TORQUE

Seat Fasteners:
18 ft-lbs (24 Nm)

NOTE

For models with a passenger seat, install and torque passenger seat fastener.

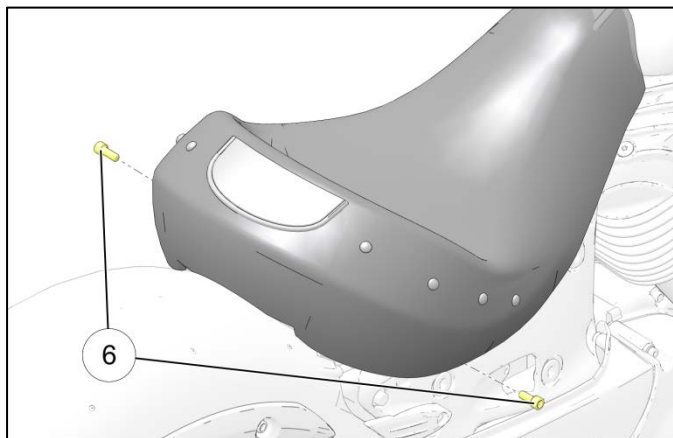

22. Using a 10 mm socket, install the fastener ⑤ securing the horn to the ignition coil bracket as shown. Torque to specification.

TORQUE

Horn to Bracket fastener:
84 in-lbs (10 Nm)

IMPORTANT

After tightening, make sure that the bottom of the horn trumpet remains parallel to the ground.

IMPORTANT – AUDIT STEP

A secondary dealer representative must verify the fastener has been torqued using a torque wrench set to the correct specification. Mark the fastener with a paint pen to indicate the audit has been completed.

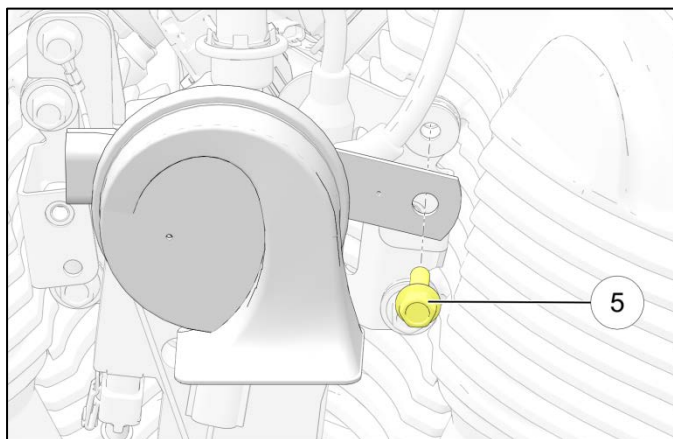

23. Connect the electrical connection to the horn connector.

NOTE

Listen for an audible “click” to confirm the connection is fully engaged.

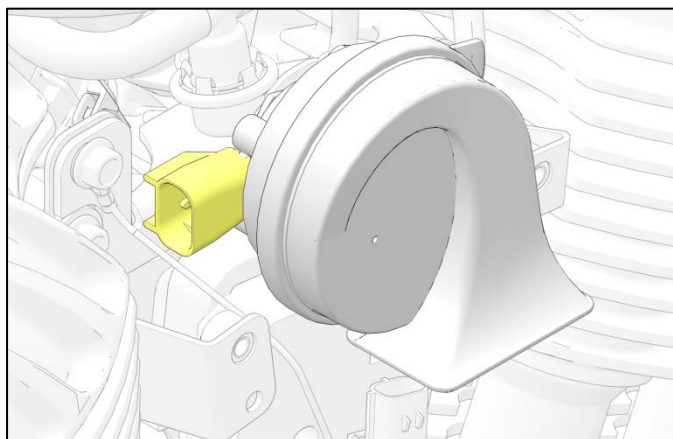

24. Install Horn Cover using three fasteners ④.
Torque fasteners to specification.

TORQUE

Horn Cover fasteners:
84 in-lbs (10 Nm)

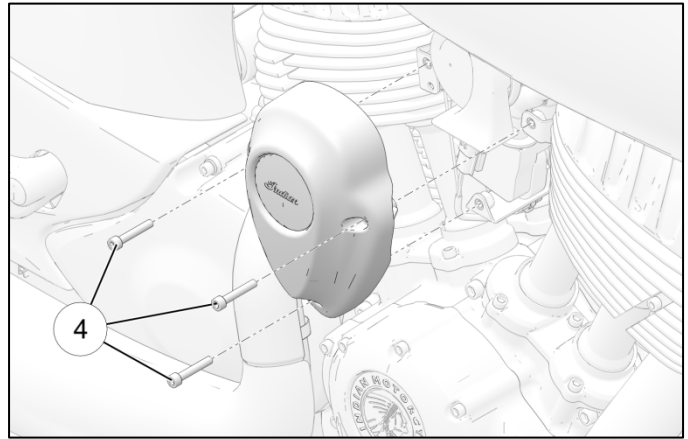

25. Install trunk (If removed)

CAUTION

Use care when installing the trunk assembly so that no electrical wire / connectors get pinched.

- a) Lift the flap at the rear of the passenger seat pad to access the vehicle side of the trunk harness connector and lay harness on fender.



- b) Slide the trunk forward ① onto the mounting bracket and lower ② the rear of the trunk until fully seated.

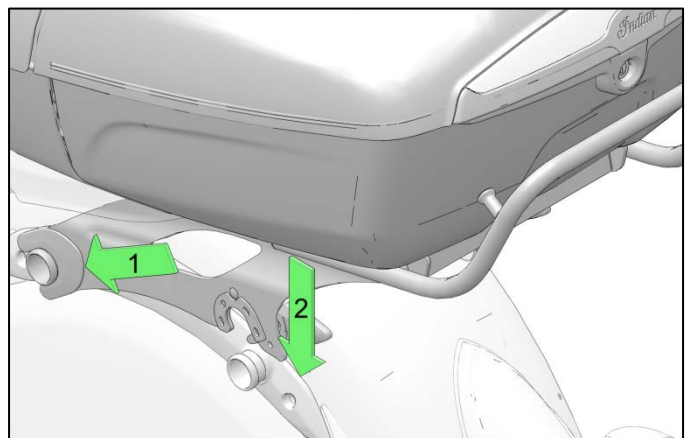

- c) Push the trunk locking levers ③ down until fully seated and the trunk is held securely in place.

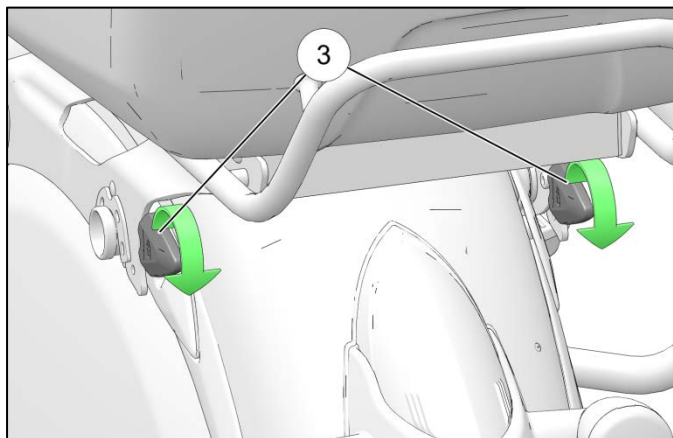

- d) Connect the trunk harness connector ②.

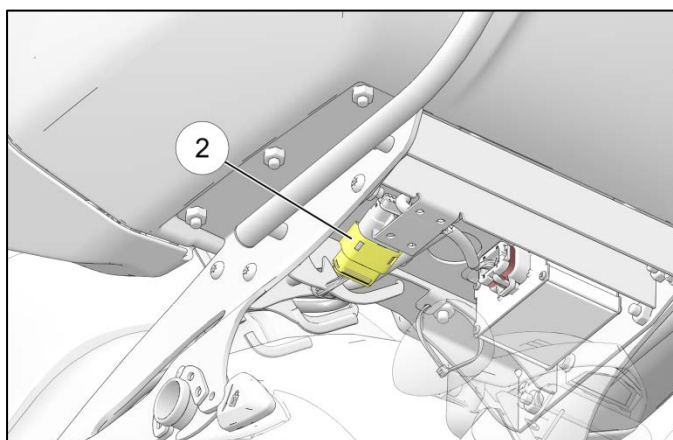

- e) Install the mounting fasteners ① into the left and right locking levers.

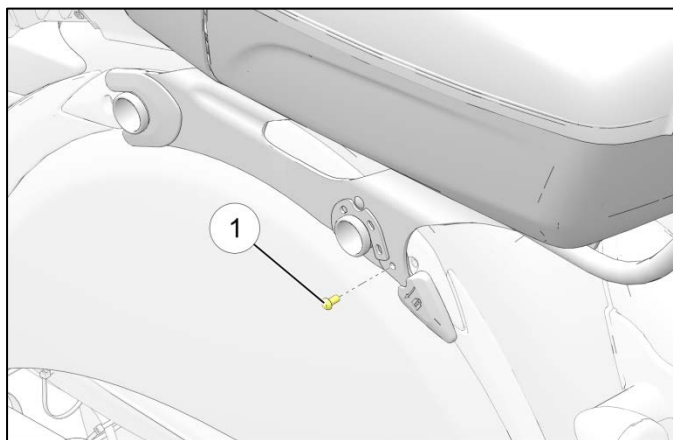

26. Install Saddlebags (If equipped).

27. Connect the motorcycle to Digital Wrench. Verify no fail codes and no MIL lights are present. Field Test the motorcycle to verify proper operation.

IMPORTANT – AUDIT STEP

A secondary dealer representative must connect the motorcycle to Digital Wrench. Verify no fail codes and no MIL lights are present.

IMPORTANT

A secondary dealer representative must field test the motorcycle before putting into service to verify proper operation.

28. File a warranty claim for I-16-03-AB and Install a completed Service Bulletin Completion Decal (7170107).

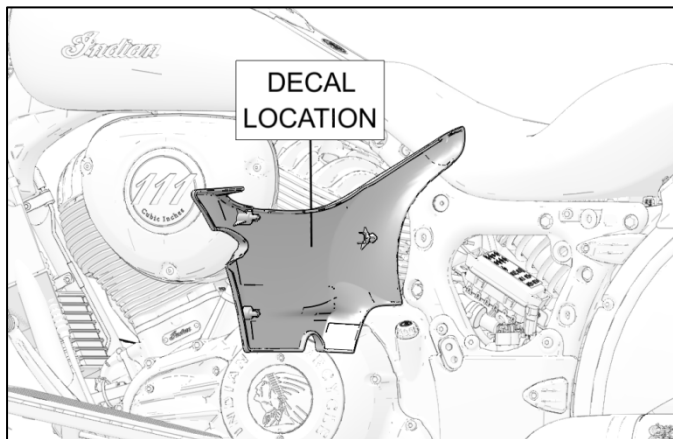

29. Replace upper side covers.

