

## Field campaign

<b>Topic</b>	Seat assemblies and instrument panel - fastener torque over check (RE16/32)
<b>Market area</b>	Bentley: worldwide (2WBE),Hongkong-Macau (5HK)
<b>Brand</b>	Bentley
<b>Transaction No.</b>	2045534/1
<b>Campaign number</b>	RA70
<b>Note</b>	
<b>Type</b>	Recall campaign
<b>US code</b>	

## Vehicle data

### Bentayga

#### Sales types

Type	MY	Brand	Designation	Engine code	Gearbox code	Final drive code
4V1*	2017	E		*	*	*

#### Chas is numbers

Manufacturer	Filler	Type	Filler	MY	Factory	From	To	Prod from	Prodto
SJA	***	**	*	*	C	011069	016098		

## Documents

Document name
<a href="#">master.xml</a>
<a href="#">4vinlist.pdf</a>

## Notes

## • Repair instructions

## Technical background

During a routine system review missing torque data was discovered against a small number of bolts tightened during vehicle assembly. As a precaution, an overcheck is required on these joints to confirm correct tightening.

## Remedy

Referencing VINlist (attached 4vinlist.pdf) produce a job list for your specific VIN, access each required fastener on the VIN specific list and over check the fastener torque

## Customer notification

The keepers of the affected vehicles will be notified in writing.

Make sure all affected vehicles are checked and repaired as part of the workshop visit. Write the Campaign to be performed on the workshop order before the customer signs it.

If the campaign was not performed during a workshop visit, inform the customer straight away about the campaign.

Please also inform your new and used car department, so that these vehicles can be checked and repaired straight away and not only before the sale.

## Warranty accounting instructions

Warranty time for each specific vehicle is in column AB of the attached matrix (attachment 4vinlist.pdf) use that time in conjunction with the following code:

Warranty Type	710 or 790
Labour Operation Code	72 98 05 99
Damage Service Number	RA70
Damage Code	00 99
Criteria ID	01

## Genuine parts

### **Potential consumable parts list**

Description	Part number	Potential quantity
Clam shell fir tree	3W0867333C	6
Seat belt buckle front seat bolt	N98923602	2
5 Seat 60% runner end stop	36A885968A – End stop block	1
5 Seat 60% runner end stop	36A885967A – End stop block	1
Seat rail cover	4M08813454PK	8
Seat rail cover	4M0881345A4PK	4
Seat rail cover	36A881346	4
Seat cushion grommet	7P0886373A	5
Seat belt guide	36A857763A	1

## Part supply

Any genuine required replacement parts should in all cases be ordered from Bentley Motors Limited Crewe or through your regional Bentley parts distribution centre

## Parts despatch control

## Questions and answers

### Which fault/damage do the affected vehicles have?

On a small number of vehicles Bentley has identified that there is a risk that specific joints tightened during the assembly of the vehicle may not have been correctly tightened.

### What is the reason to do the overcheck?

During a system review missing torque data was discovered against a small number of joints tightened during the assembly of the vehicle. As a precaution, an overcheck is required on these joints to confirm correct tightening.

### What is the risk of a loose joint?

This is a precautionary over check only. If one was found loose there is a risk of reduced occupant protection

### Which vehicles are affected by the fault/damage?

Specific Bentley Bentayga's with missing data identified built between November 2015 to November 2016

### Are all vehicles affected by the fault/damage?

No, only Bentley Bentayga vehicles where missing data has been identified

### Can I use the vehicle till it is checked/repaired?

Yes, the vehicle can be used until it is repaired. But an appointment for the repair should be made as soon as possible.

### Is there a danger for the consumers?

Where it is found that the joints are not correctly tightened there is a risk of reduced occupant protection

### Have there been any customer complaints?

No, Bentley is conducting this campaign as a precaution

### What precisely does the repair involve?

For each vehicle affected by the action there is one or more joint identified as requiring checking. The retailer will be informed of which joints require checking on which vehicle and then follow the process in the TPI to check that joint

### Can the driver recognise the fault?

If the driver recognises a noise or vibration associated with a vehicle seat they should immediately inform their retailer

### How long does the repair take?

This depends on which joints require overchecking. Most cars will be completed in 2 hours

### Do I have to make an appointment?

Yes, that's important. Your retailer needs to ensure that the necessary parts for your vehicle are available.

---

## Repair instructions

**Notes**

## Technical background

During a routine system review missing torque data was discovered against a small number of bolts tightened during vehicle assembly. As a precaution, an overcheck is required on these joints to confirm correct tightening.

## Check

If the vehicle is not already listed as repaired in the "Repair history" (in Elsa pro), check for the presence of red campaign completion mark top of the main electrical junction box (see Figure 63), should neither be evident carry out the required work in accordance with these instructions.

## Control

# Genuine parts

## Potential consumable parts list

Description	Part number	Potential quantity
Clam shell fir tree	3W0867333C	6
Seat belt buckle front seat bolt	N98923602	2
5 Seat 60% runner end stop	36A885968A – End stop block	1
5 Seat 60% runner end stop	36A885967A – End stop block	1
Seat rail cover	4M08813454PK	8
Seat rail cover	4M0881345A4PK	4
Seat rail cover	36A881346	4
Seat cushion grommet	7P0886373A	5
Seat belt guide	36A857763A	1

## Work

### For all cars and all jobs

Referencing VIN list (attached 4vinlist.pdf) produce a job list for your specific VIN, access each required seat fastener on the VIN specific list and over check the fastener torque

**Warning before any work is carried out on the car, refer to 'Precautions – Passive restraint systems and components', Failure to comply with the instructions could lead to inadvertent deployment of the vehicle air bags.**

- **Never attempt to dismantle or repair an air bag**
- **Remove the air bag fuse and replace it with dummy fuse WT10033. Position the dummy fuse ribbon in a prominent position to alert other service technicians that the air bag fuse has been removed. Refer to 'Air bag fuse – To remove and fit' Rep.Gr.72**
- **On completion use guided fault finding to clear any fault codes created as a result of performing this campaign**

**Only refit trim parts once all the required fasteners for this specific car have been checked**

**Note:** Each car contains four thorax air bags. Each outer seat contains a thorax air bag



Figure 1

**Note:** A number of air bag connectors may require disconnecting to facilitate this work. Ensure the additional locking mechanism associated with yellow air bag connectors is released before attempting to pull the connector apart. Figure 1 shows a hook (P) being used to release the additional locking mechanism.

**Note:** Images may depict left hand or right hand the corresponding part will be symmetrically opposite

## Front Seat All Cars

### Job 1 - Front left hand seat thorax air bag fastener torque check

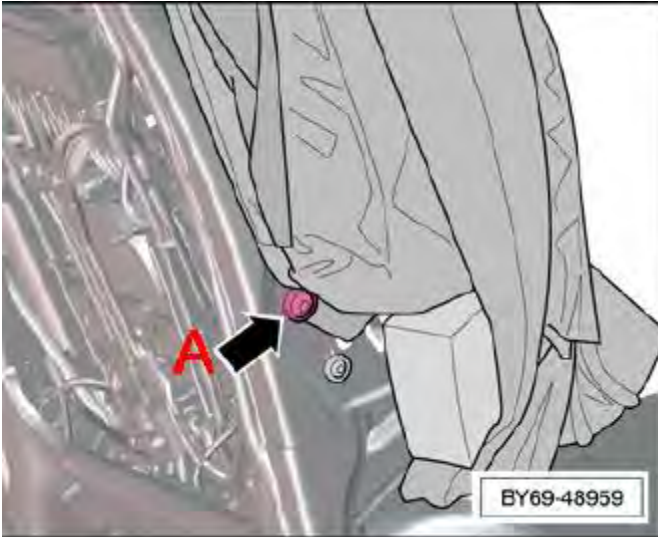

Figure 2

Airbag fastener part number N90737101 torque 9Nm location for all front seats (see Figure 2)

1. Raise the front seat to its highest extent and move forwards until there is sufficient room in the rear passenger footwell to gain access to the underside of the front seat

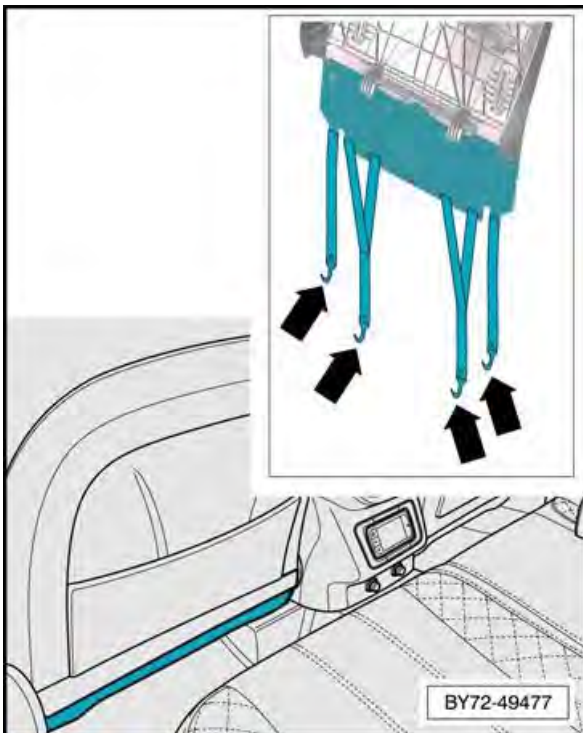

Figure 3

2. Unclip the four elasticated clips – arrows – from the underside of the seat – take note of the position of the clip anchor points to aid installation (see Figure 3)

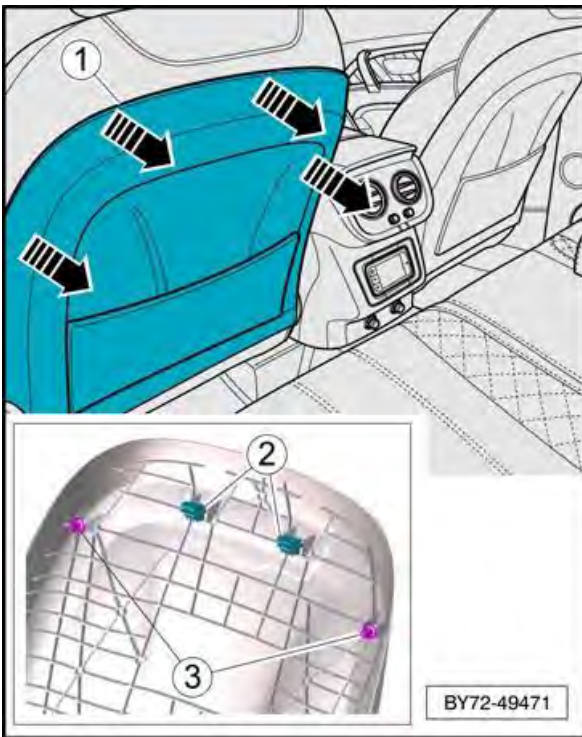

Figure 4

3. The upper section of the clamshell -1- is secured to the squab by two tabs -2- and two fir tree clips -3-. From the top of the clamshell, slide a thin bladed trim tool downwards, between the clamshell and the squab cover and release the tabs from the squab. Simultaneously pull rearwards to fully disengage the tabs

Caution: Do not pull on the clamshell without releasing the upper tabs, this could cause irreparable damage to the tabs, requiring the clamshell to be replaced

Note the fir tree clips -3- will deform during removal. Discard the fir tree clips (see Figure 4)

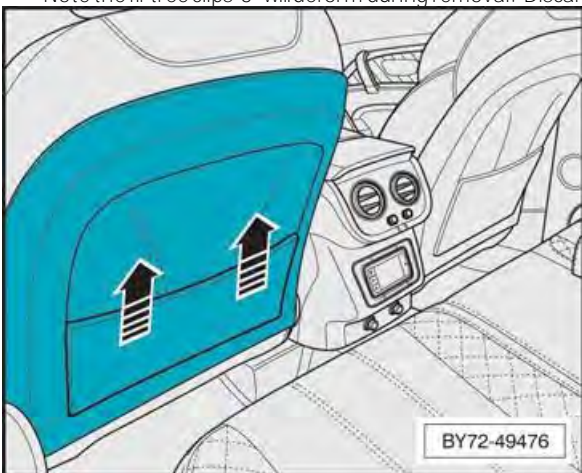

Figure 5

Lift the clamshell upwards – arrows - to release the lower tabs and remove clamshell (see Figure 5)

4. Position the seat as far forwards as possible and tilt the squab forwards slightly – This will prevent the 'B' post impeding access to the air bag
5. Switch off the ignition

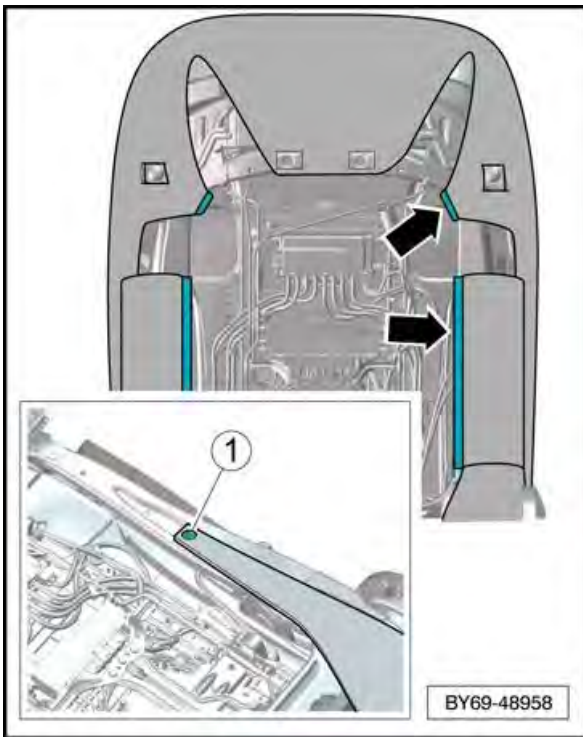

Figure 6

6. Release the squab cover clips—arrows— from the air bag side of the squab frame (see Figure 6)
7. Remove the clip -1- and remove the cover flap. Fold the flap through the underside of the squab and fold back the cover to expose the air bag (see Figure 6)

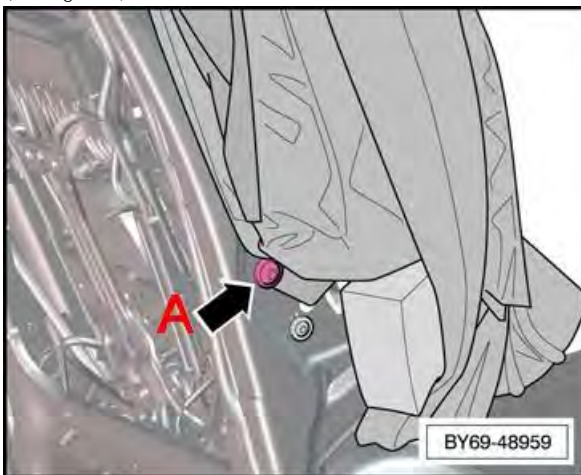

Figure 7

8. Using an in date calibrated torque wrench apply 9 Nm to fastener (A) (part number N90737101 - M6 X 12) for both front seats (see Figure 7)
9. Installation is the reverse of removal procedure, noting the following
  - Inspect the clamshell clipping points for signs of damage. If damage is evident the clamshell MUST be replaced
  - Fit NEW fir tree clips to the clamshell
  - Locate the lower tabs inside the seat squab frame
  - Locate the upper clips into the relevant slots and push inwards firmly to engage clips
  - Connect elasticated clips to the underside of the seat

## Job 2 - Front right hand seat thorax air bag fastener torque check

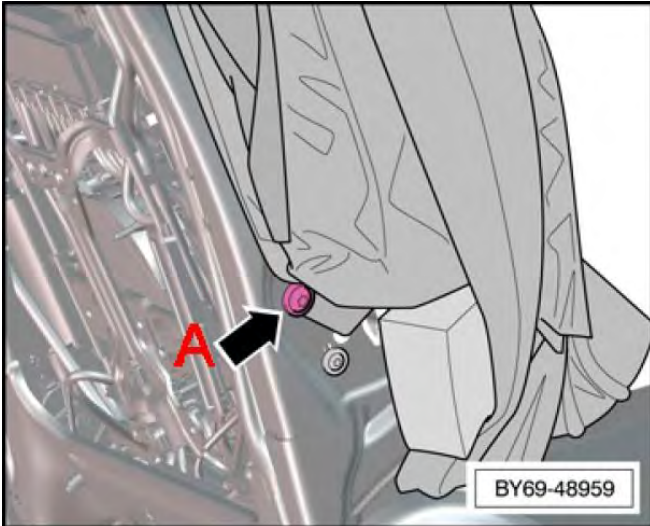

Figure 8

Front right hand seat thorax air bag fastener part number N90737101 torque 9Nm (see Figure 8)

1. Follow procedure "Job 1" above to torque check front right hand seat thorax air bag fastener

## Job 3 - Front left hand seat belt buckle fastener torque check (front left hand seat must be removed)



Figure 9

Front seat belt buckle fastener part number N98923602 torque 40Nm (see Figure 9)

1. Switch off ignition
2. Remove front seat Rep.Gr.72
3. Place the seat on the seat repair stand –VAS 6136- or a suitable secure surface. Refer to "Front seat repair stand – To repair" Rep.Gr.72
4. Using an in date calibrated torque wrench apply 40 Nm to fastener (T) (part number N98923602) (see Figure 9)

## Job 5 - Front right hand seat belt buckle fastener torque check (front right hand seat must be removed)



Figure 10

Front seat belt buckle fastener part number N98923602 torque 40Nm (see Figure 10)

1. Follow procedure "Job 3" above to torque check front right hand seat belt buckle fastener

## Job 4 – Front left hand seat squab marriage torque check (front left hand seat must be removed)



Figure 11

Front squab marriage fasteners part number WHT002796B torque 33Nm (see Figure 11)

1. Switch off ignition
2. Remove front seat Rep.Gr.72
3. Place the seat on the seat repair stand –VAS 6136- or a suitable secure surface. Refer to "Front seat repair stand – To repair" Rep.Gr.72

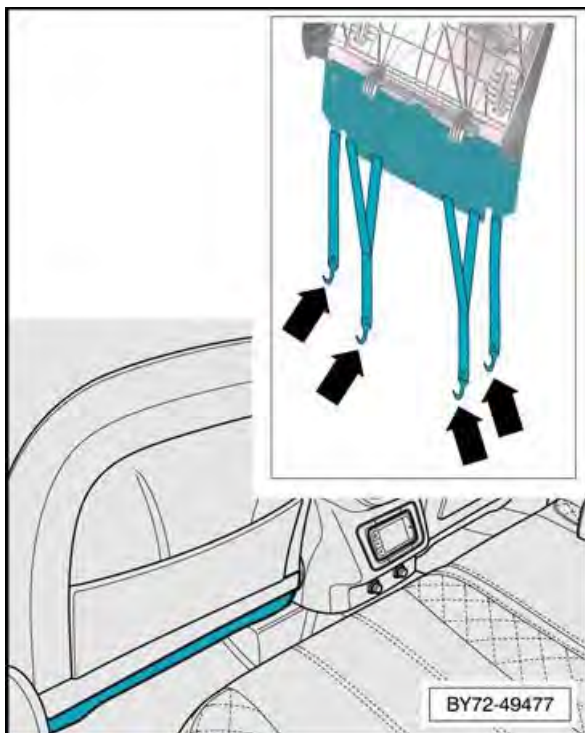

Figure 12

4. Unclip the four elasticated clips—arrows- from the underside of the seat—take note of the position of the clip anchor points to aid installation (see Figure 12)

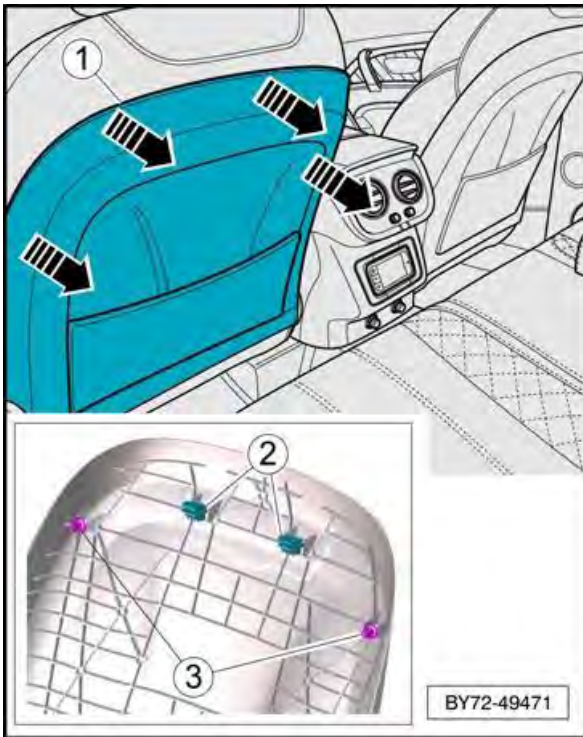

Figure 13

5. The upper section of the clamshell -1- is secured to the squab by two tabs -2- and two fir tree clips -3-. From the top of the clamshell, slide a thin bladed trim tool downwards, between the clamshell and the squab cover and release the tabs from the squab. Simultaneously pull rearwards to fully disengage the tabs  
Caution: Do not pull on the clamshell without releasing the upper tabs, this could cause irreparable damage to the tabs, requiring the clamshell to be replaced  
Note the fir tree clips -3- will deform during removal. Discard the fir tree clips (see Figure 13)

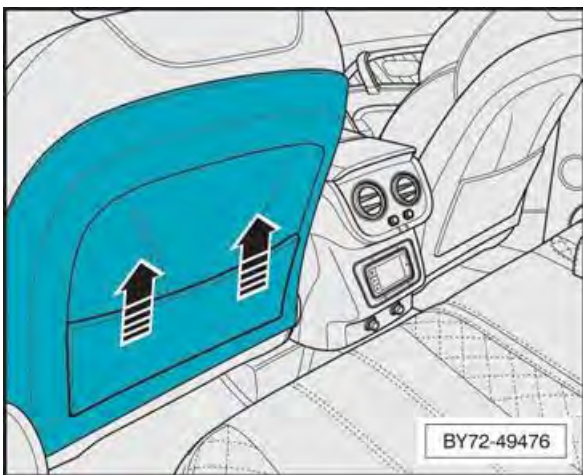

Figure 14

6. Lift the clamshell upwards—arrows- to release the lower tabs and remove clamshell (see Figure 14)

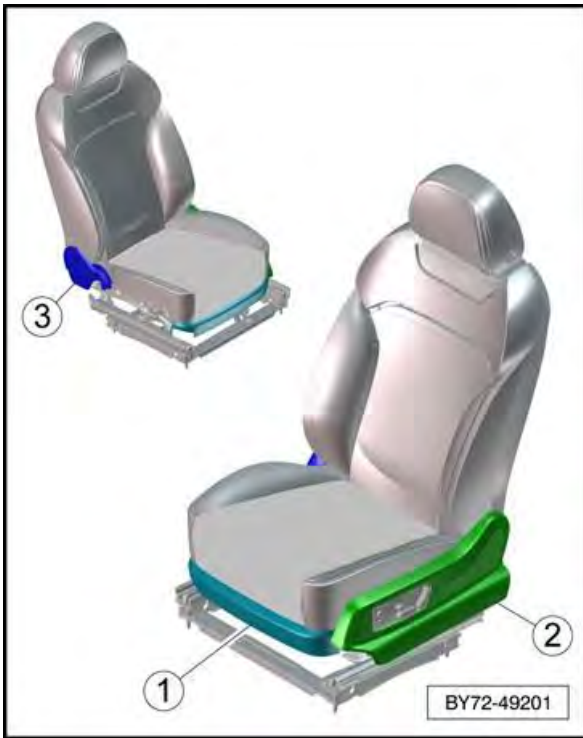

Figure 15

7. Remove sidevalance (2) (see Figure 15)

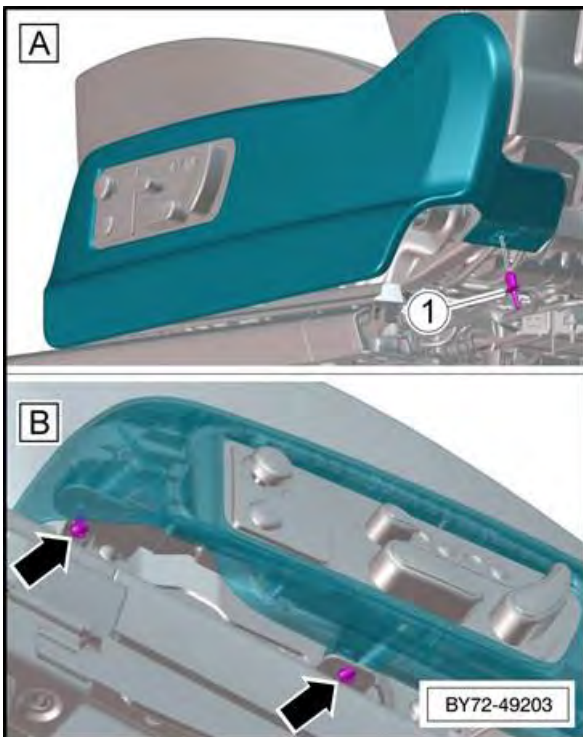

Figure 16

- Remove the expansion rivet -1- at rear of seat (see Figure 16 A). To remove the expansion rivet, push in the centre pin then remove rivet
- On the underside of the seat remove the two fixings—arrows- (2.5Nm) (see Figure 16 B)

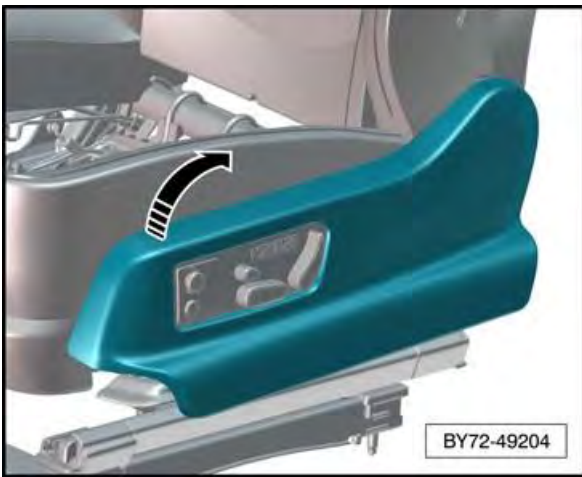

Figure 17

- From the front edge lift the valance up and back to release the side valance from the clipping points (see Figure 17)

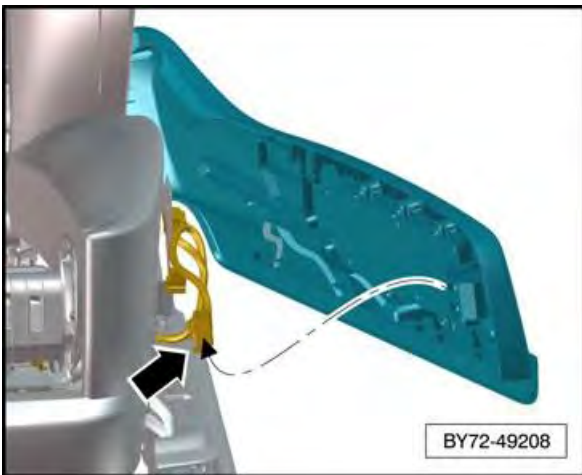

Figure 18

- Disconnect the electrical connector –arrow- for the switchpack and remove the side valance (see Figure 18)

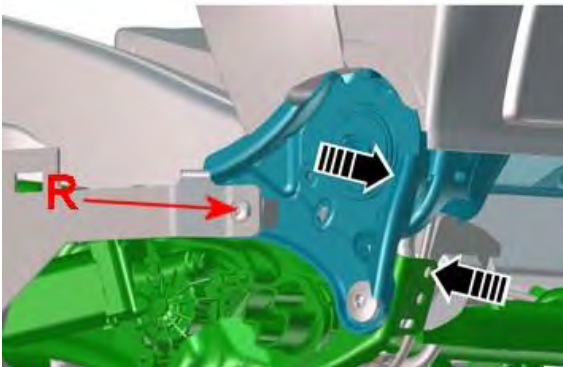

Figure 19

- To enable access to the outer front squab marriage fastener the side valance subframe fastener (R) should be released (see Figure 19)
- Remove the inner valance (3) (see Figure 15)

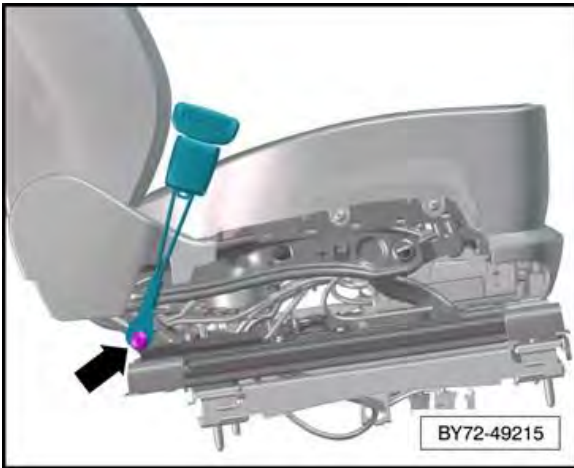

Figure 20

- Remove the fixing—arrow- (40Nm) and discard, fixing is single use, lower the seat belt buckle (see Figure 20)

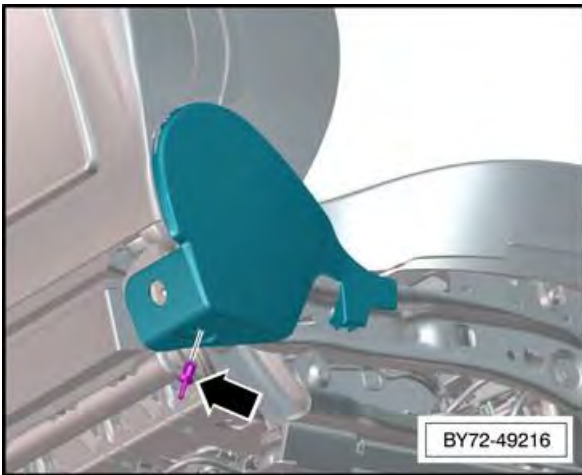

Figure 21

- Remove the expansion rivet -1- at the rear of the seat (see Figure 21)

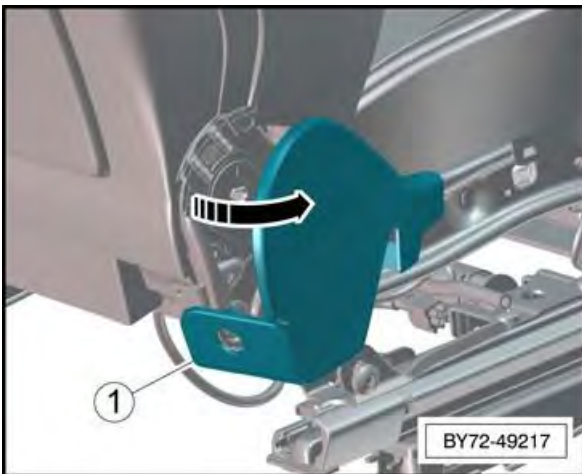

Figure 22

- From the rear edge of the valance, pull outwards—arrow- to release from the clipping points (see Figure 22)

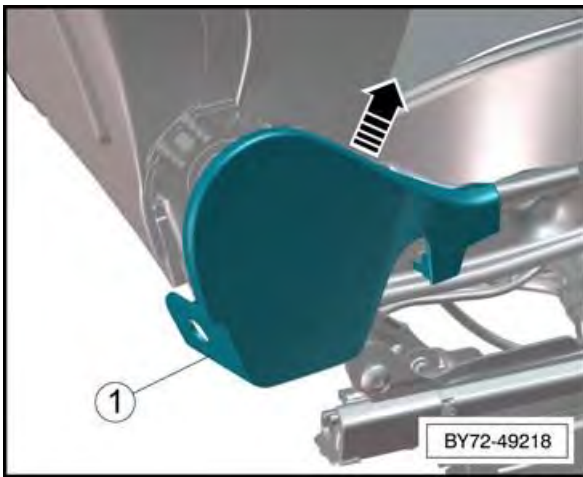

Figure 23

- Pull the valance upwards—arrow- and remove (see Figure 23)



Figure 24

- Using an in date calibrated torque wrench apply 33 Nm to fasteners (S), four per front seat, (part number WHT002796B M10x16) (see Figure 24)
- When refitting the seat belt buckle ensure a new fastener, part number N98923602, is used and torque tightened to 40Nm (see figure 9)
- To aid in refitting the above valance the procedure in the workshop manual should be referenced Rep Gr 72 Front seat valance - To remove and fit

## Job 6 – Front right hand seat squab marriage torque check (front right hand seat must be removed)



Figure 25

- Follow procedure "Job 4" above to torque check front right hand seat squab marriage fasteners

## Rear Seats - 5 Seat Cars

### Job 7 - 5 seat car - Rear 40% seat belt buckle fasteners torque check



Figure 26

Rear seat belt buckle fastener torque 50Nm (see Figure 26)

1. Remove seat cushion from 40% rear seat assembly Rep. Gr.72 Rear seat cushion - To remove and fit
2. Using an in date calibrated torque wrench apply 50 Nm to fasteners (P), (see Figure 26x)

### Job 8 - 5 seat car - Rear 60% centre seat belt reel fastener torque check (rear 60% seat must be removed)



Figure 27

Rear 60% centre seat belt reel fastener part number N98991001 torque 50Nm (see Figure 27)

The seat belt reel fastener (G) is located on the back of the seat frame therefore the outer trim cover and foam sub structure has to be partially removed to gain access

1. Switch off ignition
2. Remove 60% rear seat assembly Rep. Gr. 72. **Note:** The front bolts securing the 60% rear seat to the vehicle tighten onto an end stop block (Part numbers 36A885968A and 36A885967A). These blocks are designated as single use therefore when refitting this seat new end stop blocks must be fitted
3. Partially remove the outer leather trim cover
  - With the chrome button pressed on the headrest adjuster pull the head rest clear of the squab and remove



Figure 28

- Using a suitable trim tool, release plastic edge carrying outer leather cover from the vertical channel in the seat frame (see Figure 28)



Figure 29

- Referencing figure 29 lift the front edge (1) of the chrome seat belt guide then pull the guide forward (2) to disengage from seat frame allow the guide to slide down the seat belt webbing. It is not necessary to remove the guide from the seat belt webbing



Figure 30

- Continue to lift out the plastic edge of the outer leather cover from the top of the seat frame adjacent to the seat belt assembly (see Figure 30)
- Partially fold back the leather outer cover and push back the foam sub structure in the vicinity of the seat belt reel to reveal fastener (G) (see Figure 31)



Figure 31

- Using an in date calibrated torque wrench apply 50 Nm to fasteners (G), (see Figure 31)

### Job 9 - 5 seat car - Rear 60% outer seat belt buckle fasteners torque check (rear 60% seat must be removed)

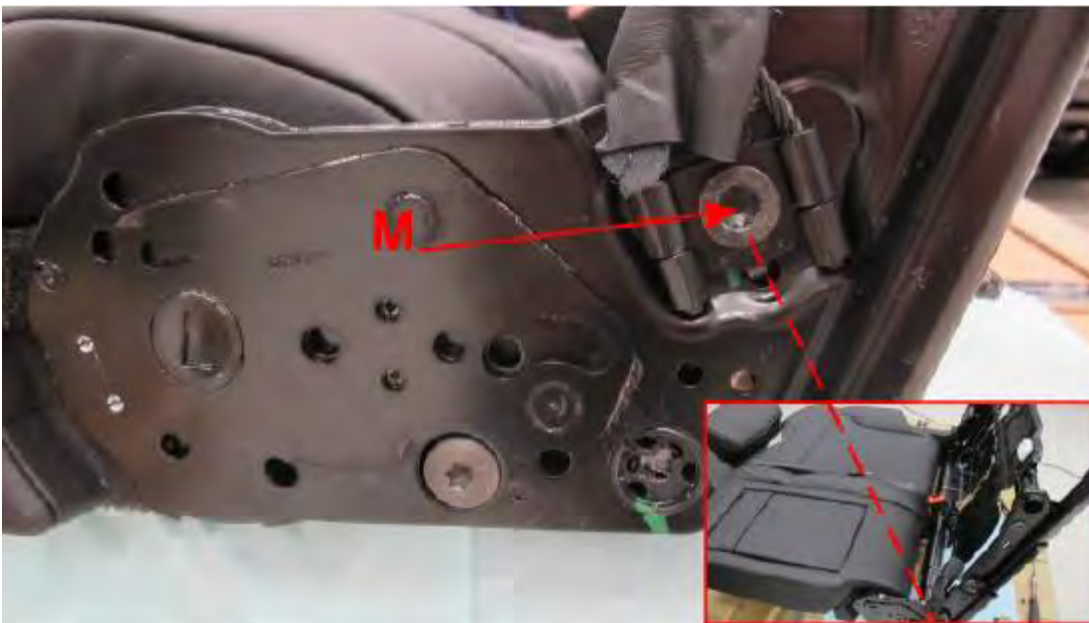

Figure 32

Rear 60% outer seat belt fastener torque 50Nm (see Figure 32)

- Switch off ignition
- Remove 60% rear seat assembly Rep. Gr. 72. **Note:** The front bolts securing the 60% rear seat to the vehicle tighten onto an end stop block (Part numbers 36A885968A and 36A885967A). These blocks are designated as single use therefore when refitting this seat new end stop blocks must be fitted



Figure 33

3. Referencing figure 33 remove 60% rear seat outer valance (L)
  - Remove fastener (K) securing valance
  - Unlatch clip (J) at base of valance
  - Rotate valance to remove from seat frame
4. Using an in date calibrated torque wrench apply 50 Nm to fasteners (M), (see Figure 32)

### Job 10 - 5 seat car - Rear 60% centre seat belt buckle fastener torque check

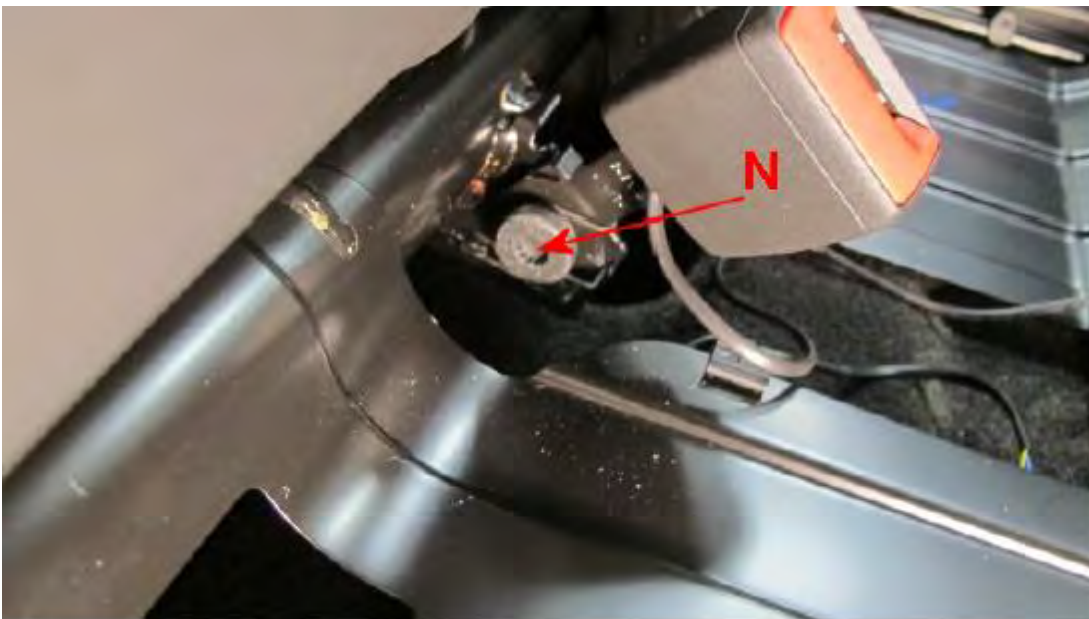

Figure 34

Rear 60% centre seat belt buckle fastener part torque 50Nm (see Figure 34)

1. Remove seat cushion from 60% rear seat assembly Rep. Gr.72 Rear seat cushion - To remove and fit
2. Using an in date calibrated torque wrench apply 50 Nm to fasteners (N), (see Figure 34)

## Job 11 - 5 seat car - Rear 60% and 40% seats thorax air bag fasteners torque check

**Note: If Job 11 is required then both the left hand and right hand rear seats require the air bag fastener to be checked**

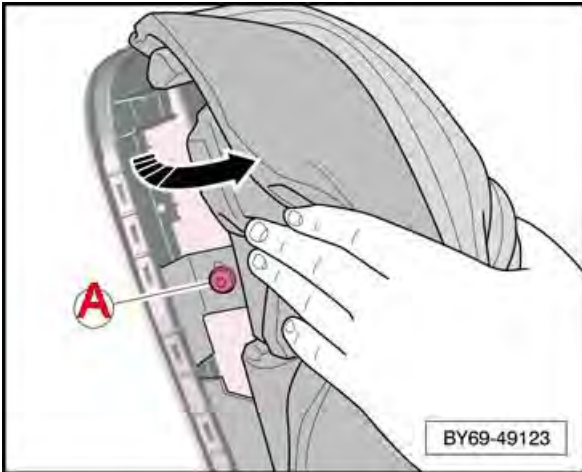

Figure 35

Air bag fastener part number N91042301 torque 9Nm fastener location for 5 seat rear only (see Figure 35)



Figure 36

1. Fold the seat back to give access to the rear of the squab (see Figure 36)

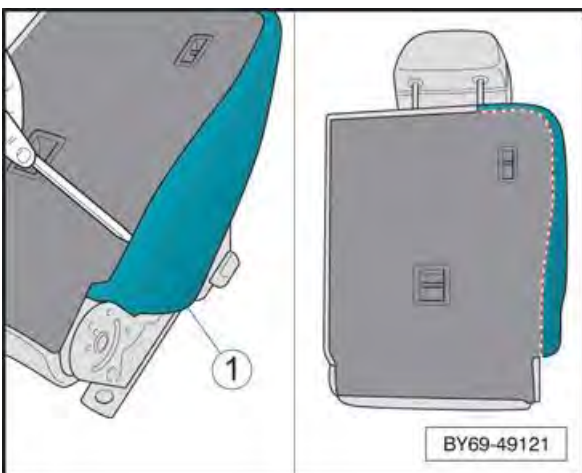

Figure 37

2. Using a suitable trim tool, release the outer and upper clipped edges –dotted line- of the seat cover - 1 - from the seat squab frame (see Figure 37)

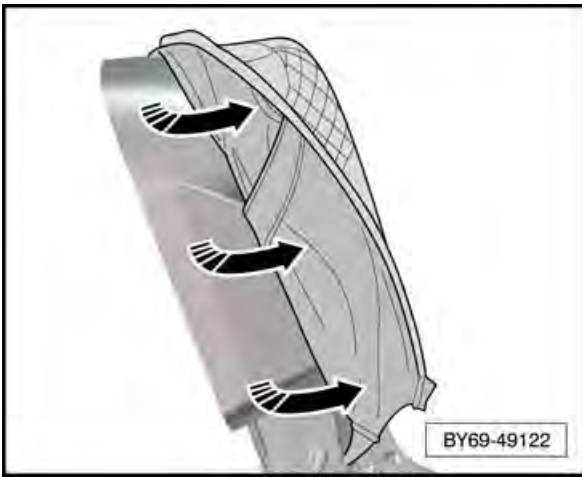

Figure 38

- Carefully fold back the trim cover (see Figure 38)



Figure 39

- Pull back the squab foam to access the air bag fastener (see Figure 39)
- Using an in date calibrated torque wrench apply 9Nm to fastener (A) (part number N91042301 - M6 x 16) for rear seats on 5 seat option (see Figure 35 and 39)

**Reminder:** If Job 11 above is required then both the left hand 60% and right hand 40% rear seats require the air bag fastener to be checked

## Job 12 - 5 seat car - Rear 60% centre seat belt long end fastener torque check (rear 60% seat must be removed)



Figure 40

Rear 60% centre seat belt buckle fastener part number N98924701 torque 50Nm (see Figure 40)

1. Switch off ignition
2. Remove 60% rear seat assembly Rep.Gr. 72. **Note:** The front bolts securing the 60% rear seat to the vehicle tighten onto an end stop block (Part numbers 36A885968A and 36A885967A). These blocks are designated as single use therefore when refitting this seat new end stop blocks must be fitted
3. Using an in date calibrated torque wrench apply 50Nm to fastener (H) (part number N98924701 – 7/16 UNF ) (see Figure 40)

## Rear Seats - 4 Seat Cars

### **Job 13 - 4 seat car - Rear left hand seats thorax air bag fastener torque check (rear left hand seat must be removed)**

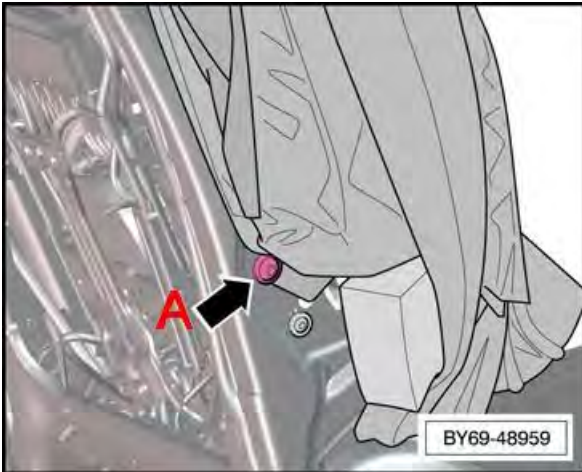

Figure 41

Air bag fastener part number N90737101 torque 9Nm location for 4 seat rear (see Figure 41)

1. Switch off ignition
2. Remove rear seat Rep.Gr. 72
3. Place the seat on the seat repair stand –VAS 6136- or a suitable secure surface. Refer to "Front seat repair stand – To repair" Rep.Gr. 72

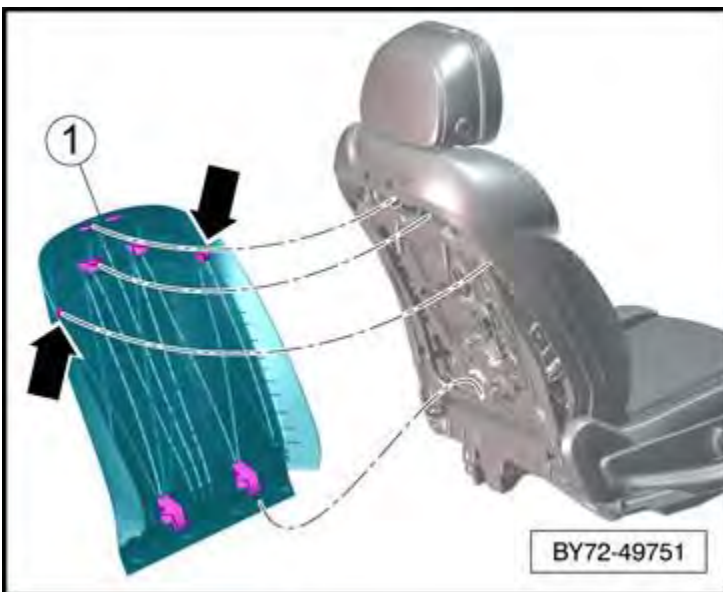

Figure 42

4. Remove the rear seat clamshell (see Figure 42)
  - The upper section of the clamshell -1- is secured to the squab by the tabs and two fir tree clips –arrow-
  - From the top of the clamshell, slide a thin bladed trim tool downwards, between the clamshell and the squab cover and release the tabs from the squab. Simultaneously pull rearwards to fully disengage the tabs
  - **Caution:** Do not pull on the clamshell without releasing the upper tabs, this could cause irreparable damage to the tabs, requiring the clamshell to be replaced
  - Note the fir tree clips -arrowed- will deform during removal. Discard the fir tree clips

- Lift the clamshell upwards to release the lower tabs and remove the clamshell

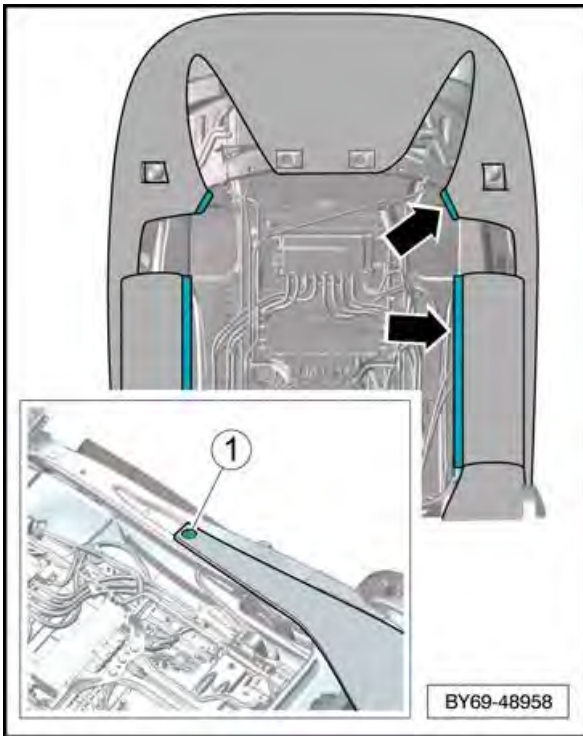

Figure 43

5. Release the squab cover clips—arrows—from the air bag side of the squab frame (see Figure 43)
6. Remove the clip -1- and remove the cover flap. Fold the flap through the underside of the squab and fold back the cover to expose the air bag (see Figure 43)

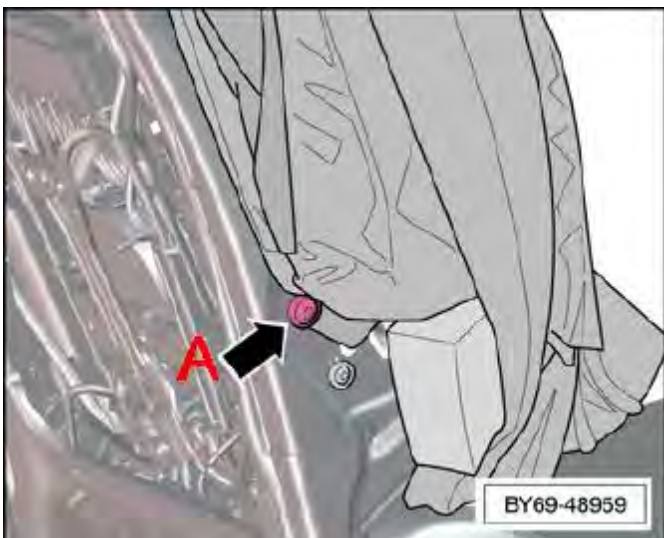

Figure 44

7. Using an in date calibrated torque wrench apply 9 Nm to fastener (A) (part number N90737101 - M6 X 12) for both front seats (see Figure 44)
8. Installation is the reverse of removal procedure, noting the following
  - Fit NEW fir tree clips to the clamshell
  - Locate the lower tabs inside the seat squab frame
  - Locate the upper clips into the relevant slots and push inwards firmly to engage the clips

## Job 14 - 4 seat car - Rear right hand seat thorax air bag fastener torque check (rear right hand seat must be removed)

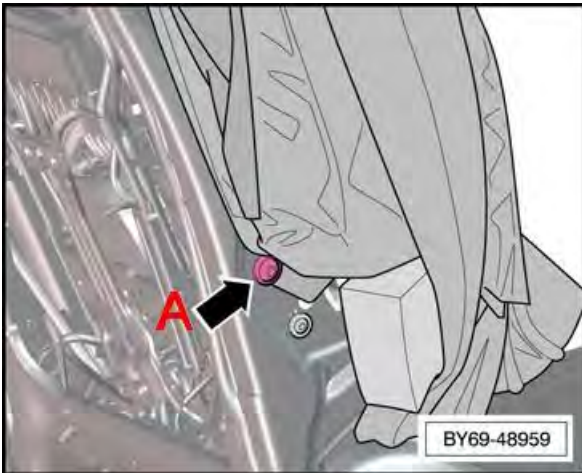

Figure 45

Air bag fastener part number N90737101 torque 9Nm location for 4 seat rear (see Figure 45)

1. Follow procedure "Job 13" above to torque check rear right hand seat thorax air bag fastener

## Job 15 - 4 seat car – Rear left hand seat squab marriage torque check (rear left hand seat must be removed)

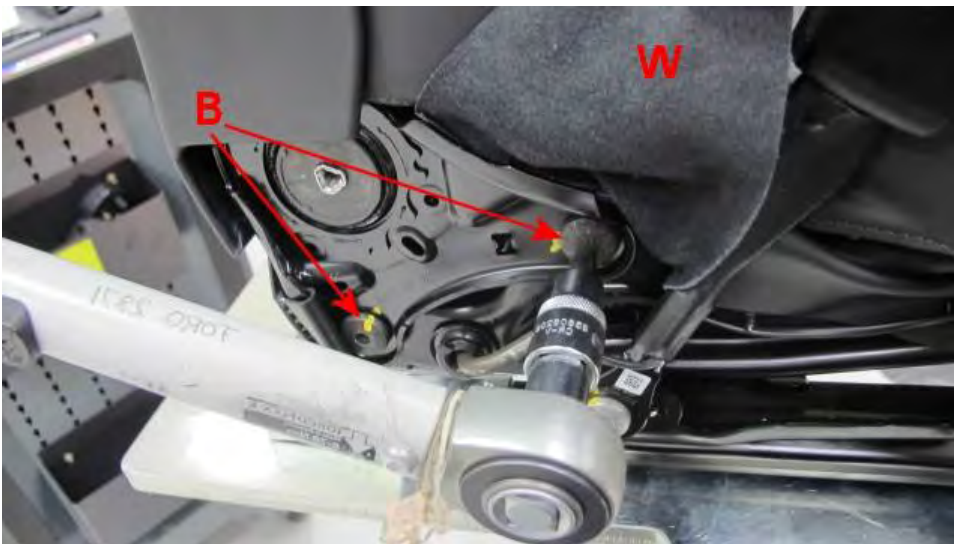

Figure 46

Rear squab marriage fasteners part number WHT002796B torque 33Nm fastener location for 4 seat rear only (see Figure 46)

1. Switch off ignition
2. Remove rear seat Rep.Gr.72
3. Place the seat on the seat repair stand –VAS 6136- or a suitable secure surface. Refer to "Front seat repair stand – To repair" Rep.Gr.72

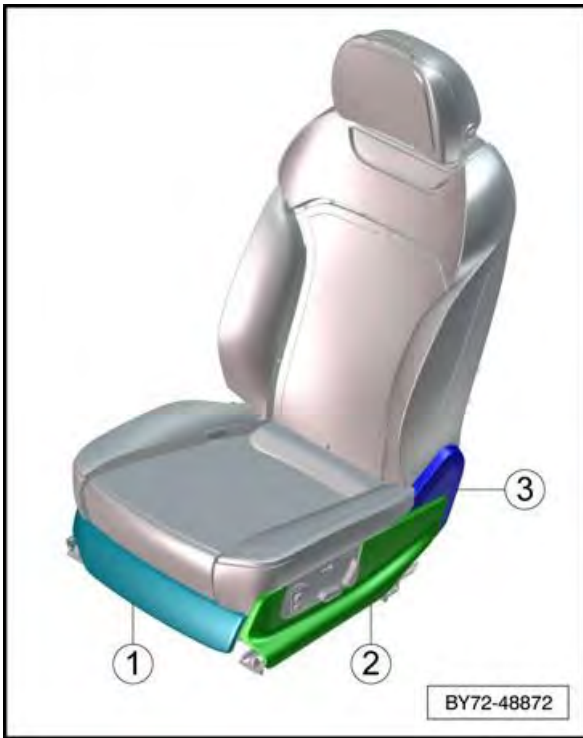

Figure 47

4. Remove rear seat side valance (2) (see Figure 47). Refer to Rear seat valance – To remove and fit Rep.Gr. 72
5. Remove rear seat side valance (rear) (3) (see Figure 47). Refer to Rear seat valance – To remove and fit Rep.Gr. 72
6. Remove fir tree peg to release trim flap (W) that enables access to inboard marriage fasteners (B) (see Figure 46)
7. Using an in date calibrated torque wrench apply 33 Nm to fasteners (B), **four per rear seat** (part number WHT002796BM10x16) (see Figure 46)

### Job 18 - 4 seat car – Rear right hand seat squab marriage fastener torque check (rear right hand seat must be removed)

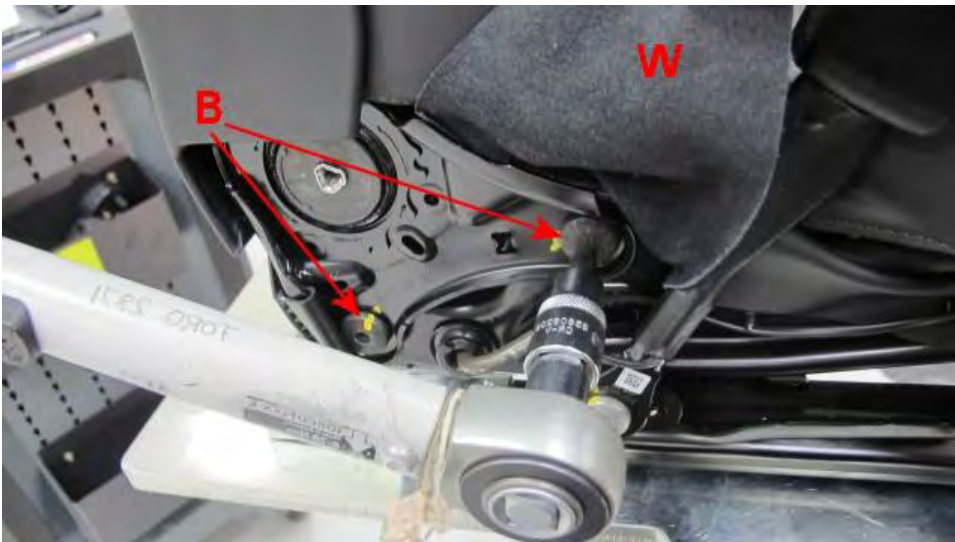

Figure 48

Rear squab marriage fasteners part number WHT002796B torque 33Nm fastener location for 4 seat rear only (see Figure 48)

1. Follow procedure "Job 15" above to torque check rear right hand seat squab marriage fastener

## Job 16 - 4 seat car – Rear left hand seat belt buckle fastener torque check (rear left hand seat must be removed)



Figure 49

Rear seat belt buckle fastener part number N98923602 torque 40Nm (see Figure 49)

1. Switch off ignition
2. Remove rear seat Rep.Gr.72
3. Place the seat on the seat repair stand –VAS 6136- or a suitable secure surface. Refer to "Front seat repair stand – To repair" Rep.Gr.72
4. Using an in date calibrated torque wrench apply 40 Nm to fastener (C) (part number N98923602) (see Figure 49)

## Job 19 - 4 seat car – Rear right hand seat belt buckle fastener torque check (rear right hand seat must be removed)



Figure 50

Rear seat belt buckle fastener part number N98923602 torque 40Nm (see Figure 50)

1. Follow procedure "Job 16" above to torque check rear right hand seat belt buckle fastener

**Job 17 - 4 seat car – Rear left hand seat ISO fix bar fastener torque check (rear left hand seat must be removed)**

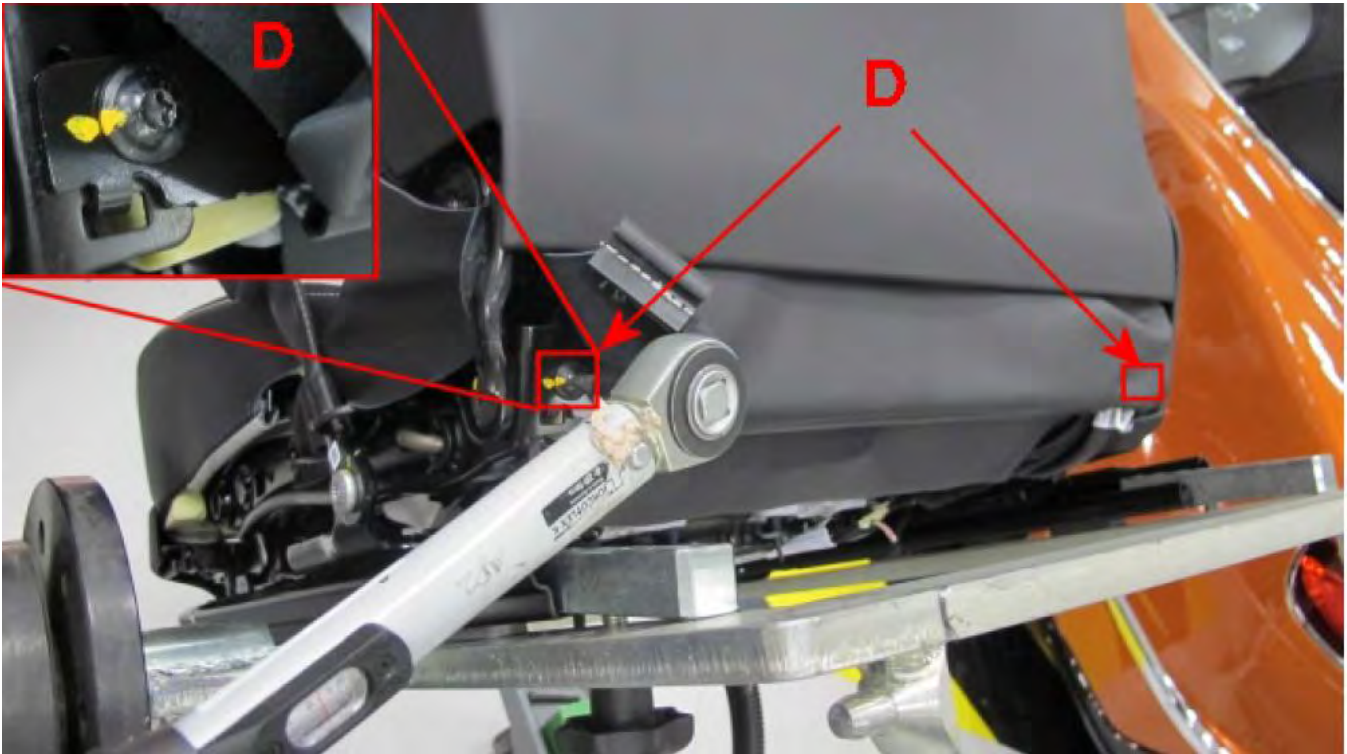

Figure 51

1. Rear seat ISO bar fastener part number N90737107 torque 8Nm (see Figure 51)
2. Switch off ignition
3. Remove rear seat Rep.Gr.72
4. Place the seat on the seat repair stand –VAS 6136- or a suitable secure surface. Refer to "Front seat repair stand – To repair" Rep.Gr.72

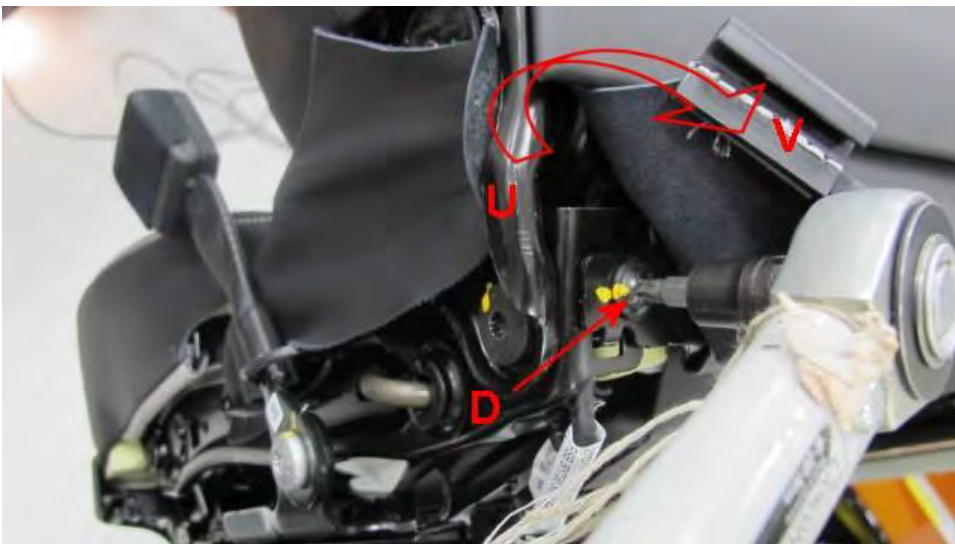

Figure 52

5. Referencing figure 52 unclip trim flap (V) from seat frame (U) to access inboard ISO bar fastener (D)

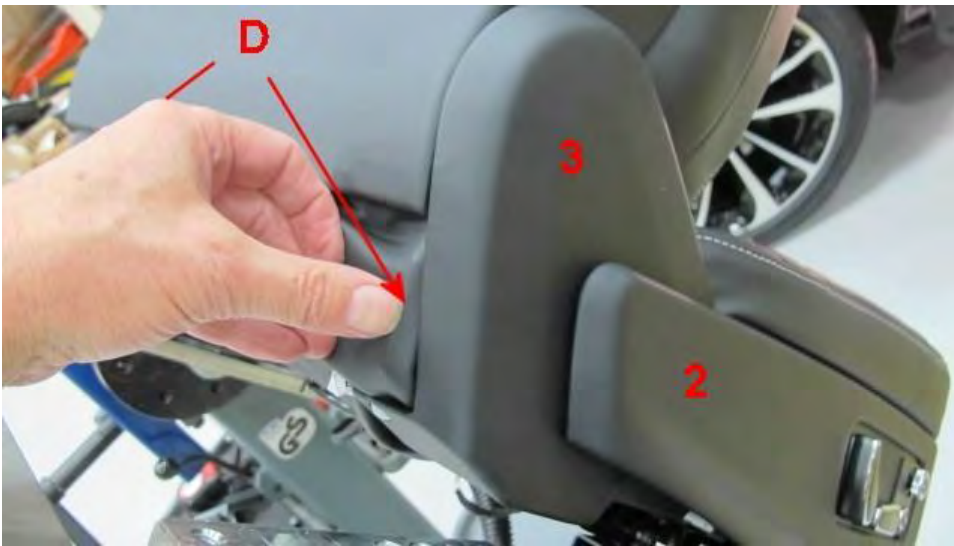

Figure 53

6. Remove rear seat side valance (2) (see Figure 53). Refer to Rear seat valance – To remove and fit Rep.Gr.72
7. Remove rear seat side valance (rear) (3) To access outboard ISO bar fastener (D) (see Figure 53). Refer to Rear seat valance – To remove and fit Rep.Gr.72
8. Unclip trim flap from seat frame to access outboard ISO bar fastener (D) (see figure 54)



Figure 54

9. Using an in date calibrated torque wrench apply 8 Nm to fasteners (D), two per seat, (part number N90737107) (see Figure 51 and 54)

### Job 20 - 4 seat car – Rear right hand seat ISO fix bar fastener torque check (rear right hand seat must be removed)

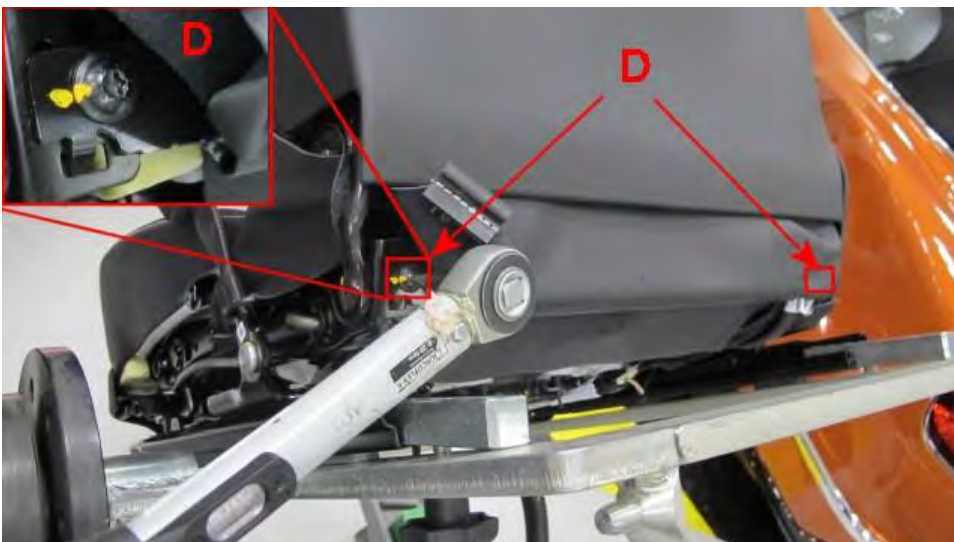

Figure 55

Rear seat ISO bar fastener part number N90737107 torque 8Nm (see Figure 55)

1. Follow procedure "Job 17" above to torque check rear right hand seat ISO fix fasteners
2. Once all the individual fasteners for the specific car have been checked then apply a red campaign completion mark to the top of the main electrical junction box adjacent to the right hand bonnet hinge (see Figure 56)

## Unit dash fasteners - torque over check (see attached 4vinlist.pdf)

**Warning before any work is carried out on the car, refer to 'Precautions – Passive restraint systems and components', Failure to comply with the instructions could lead to inadvertent deployment of the vehicle air bags.**

- **Never attempt to dismantle or repair an air bag**
- **Remove the air bag fuse and replace it with dummy fuse WT10033. Position the dummy fuse ribbon in a prominent position to alert other service technicians that the air bag fuse has been removed. Refer to "Air bag fuse – To remove and fit" Rep.Gr.72**

**Only refit trim parts once all the required fasteners for this specific car have been checked**

### Drivers side

#### **Job 21 – Steering column fastener torque check Steering column multi-function switch clamp fastener torque check**

1. Remove the lower dashboard panel (drivers side) - Refer to workshop manual Rep. Gr 70
2. Remove the steering column lower cowl - Refer to workshop manual Rep. Gr 70
3. Remove the left hand side foot well vent fastener Figure 56 (point 1)

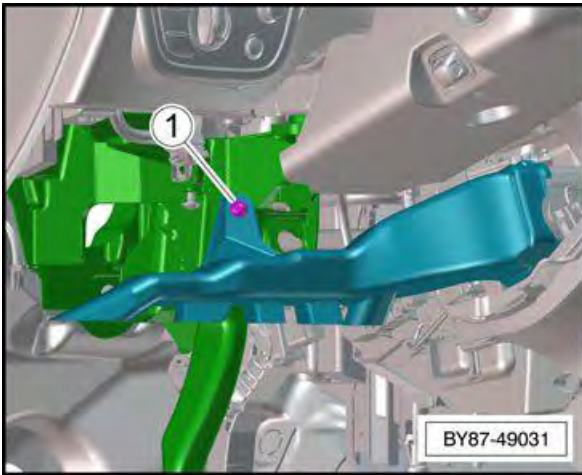

Figure 56

4. Referring to Figure 57 (points 1) check the torque of all 4 steering column fasteners part number N10665001 the torque of the fasteners is (20Nm)

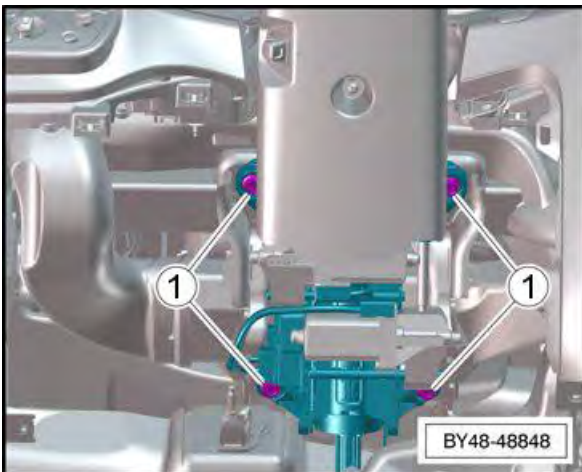

Figure 57

## Job 22 - Steering column combination switch clamp fastener torque check

1. Check the security of the steering column multi-function clamp (Figure58) the torque of the fastener is 5Nm

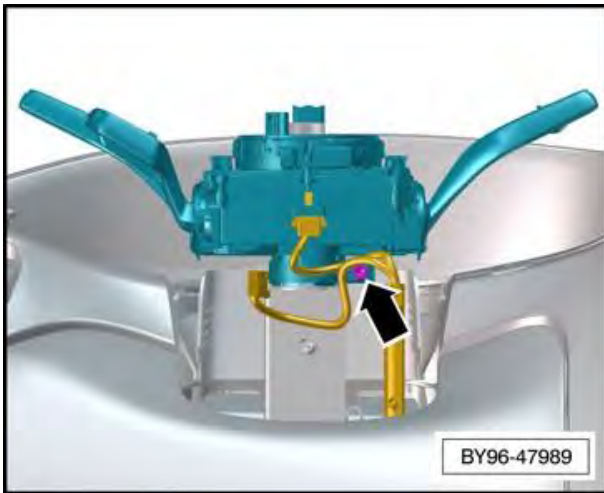

Figure 58

## Job 23 – Throttle pedal assembly fastener torque check

1. Check the security of the throttle pedal assembly fastener part number N10714801 (Figure59 point 1) the torque of the fastener is 8Nm

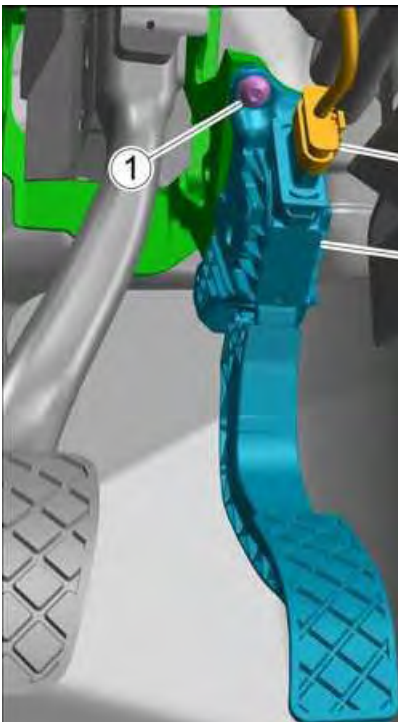

Figure 59

2. Refit the previously removed components – Refer to the applicable Workshop manual procedures

## Passenger side

### Job 24 - Passenger facia panel fastener torque check

1. Remove the passenger side dashboard side trim panel Refer to workshop manual Rep. Gr 70 (Figure 60)

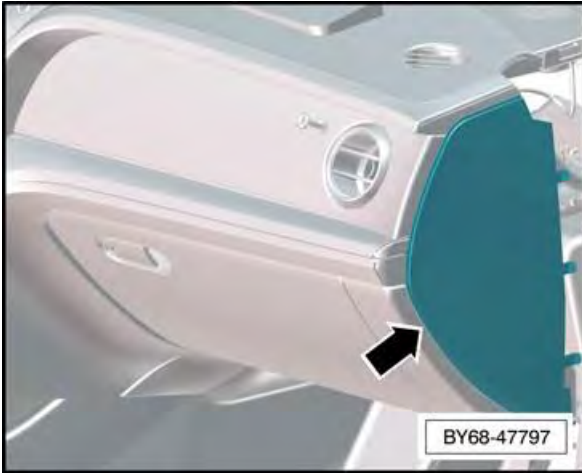

Figure 60

2. Check the security of the passenger side facia panel fastener N90918701 (Figure 61) torque check the fastener to 1.5Nm



Figure 61

### Job 25 - Passenger airbag fastener torque check

**The next part of this procedure requires access to the passenger airbag, the passenger airbag does not need to be removed, only the torque of four fasteners require checking**

1. Access the Passenger air Bag , Refer to **Passenger's** airbag (NX3) –To remove and fit
2. Check the security of the four airbag retaining fasteners part number N91093502 (Figure 62) torque check the fasteners to 9Nm

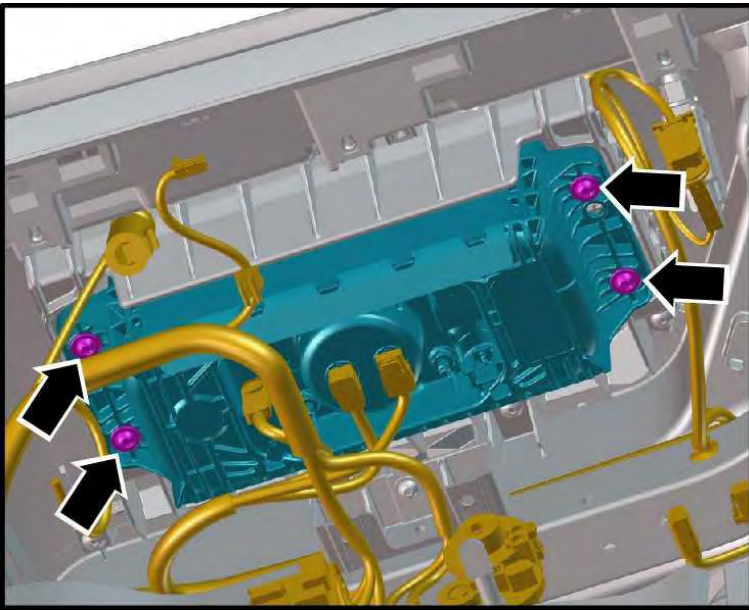

Figure 62

## Identification



Figure 63

Red campaign completion mark to the top of the main electrical junction box adjacent to the right hand bonnet hinge (see Figure 63)