



SAFETY RECALL BULLETIN

SUBJECT:			No: SR-16-010
WINDSHIELD WIPER MOTOR – SAFETY RECALL CAMPAIGN			DATE: December, 2016
			MODEL: 2011–2015 Outlander Sport / RVR
CIRCULATE TO:	<input checked="" type="checkbox"/> GENERAL MANAGER	<input checked="" type="checkbox"/> PARTS MANAGER	<input checked="" type="checkbox"/> TECHNICIAN
<input checked="" type="checkbox"/> SERVICE ADVISOR	<input checked="" type="checkbox"/> SERVICE MANAGER	<input checked="" type="checkbox"/> WARRANTY PROCESSOR	<input checked="" type="checkbox"/> SALES MANAGER

PURPOSE

This bulletin provides instructions for replacing the windshield wiper motor on affected vehicles.

BACKGROUND

Water can potentially drop down onto the front wiper motor through a gap between the front deck garnish (the body piece between the hood and windshield) and the front windshield. If this occurs, water could potentially collect in the area of the wiper motor breathing hole. If the wiper motor is not operating, this water can then potentially enter the wiper motor through the breathing hole. If this occurs, such water intrusion over time may cause internal corrosion and/or electrical conduction failure resulting in nonoperation of the windshield wiper motor.

If the windshield wiper motor stops operating, the driver will not be able to activate the windshield wipers, reducing driver visibility under certain conditions and increasing the risk of a vehicle crash.

AFFECTED VEHICLES

2011–2015 Outlander Sport / RVR

IMPORTANT

Affected new or used inventory vehicles must be repaired before the vehicle is delivered. Dealers must check their inventory vehicles' VINs on the Warranty Superscreen to verify whether the vehicle is involved in this recall campaign. It is a violation of Federal law for a dealer to deliver a new motor vehicle or any new or used item of motor vehicle equipment (including a tire) covered by the notification under a sale or lease until the defect or noncompliance is remedied.



2. Remove windshield wiper nut caps.
3. Open the hood.



4. Remove windshield wiper nuts.
5. Remove windshield wiper arm and blade assembly.



6. Remove front deck covers (if equipped).

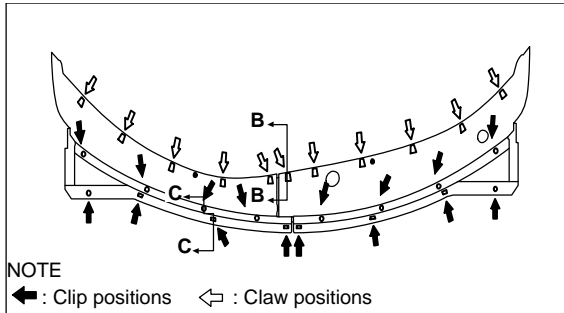

7. Remove front deck garnish.



8. Separate the wiper link rod joint from wiper motor link plate.

NOTE: Cover the separation tool with a soft cloth to prevent boot cap damage.

9. Unbolt wiper motor and link assembly.
10. Disconnect wiper motor connector from wiper motor.

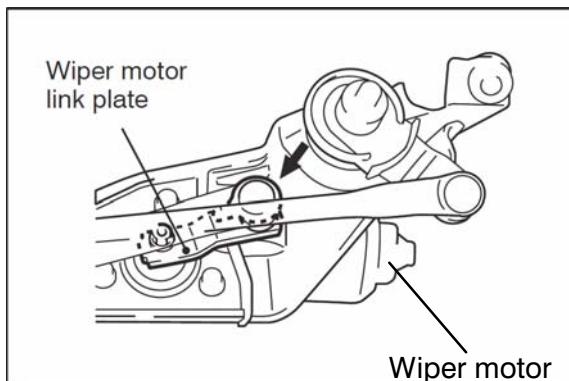
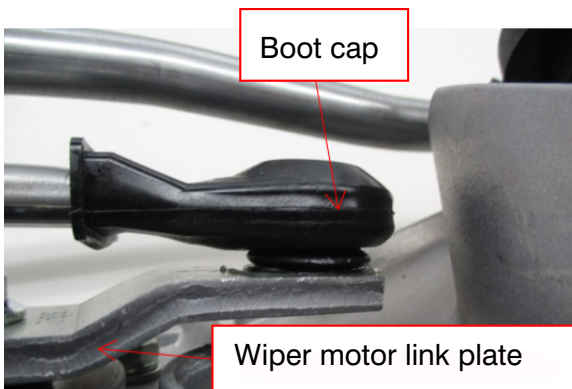

11. Unbolt and remove the wiper motor link plate from the wiper motor.

!! IMPORTANT !!

Do **not** remove the link plate from the **new motor**.

12. Unbolt wiper motor from wiper link.



13. Verify that the new wiper motor has a breathing hole cap with a water proof cloth, as illustrated.

!! IMPORTANT !!

Do **not** remove the link plate from the **new motor**.



14. Bolt new wiper motor to wiper link.
15. Connect wiper motor connector to wiper motor.



16. Fill the wiper link rod joint's resin cap with Multipurpose grease MZ100915EX (SAE J310, NLGI No. 2 or equivalent).



17. Bolt wiper motor and link assembly to vehicle.



18. Connect wiper link rod to wiper motor link plate.

19. Reconnect the battery.

20. Activate the windshield wipers one time, to move wiper link into initial position.

21. Reinstall front deck garnish and deck covers (if equipped).

22. Reinstall wiper arm and blade assembly as illustrated.

Unit: mm (in)

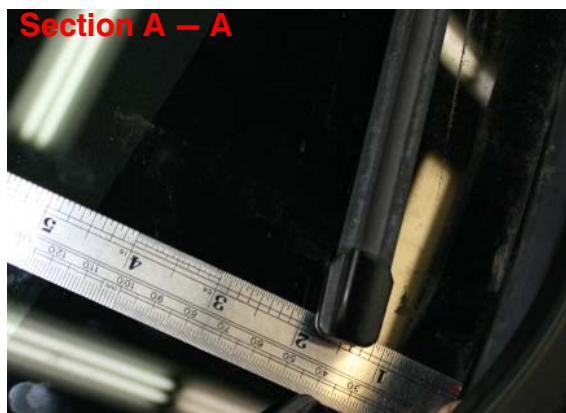
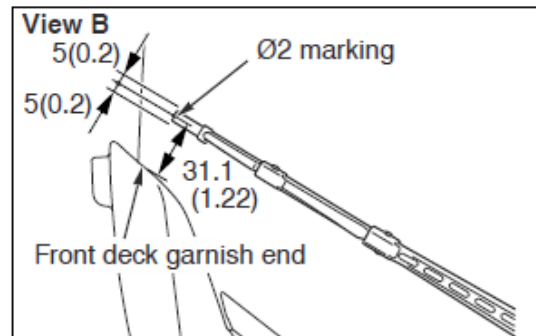
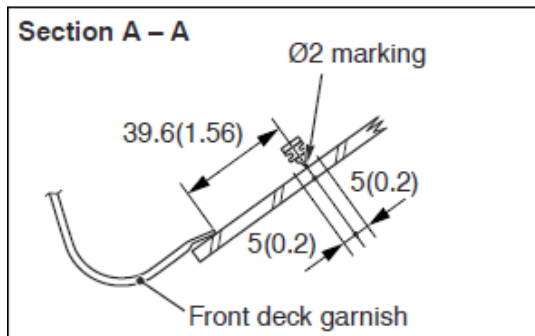
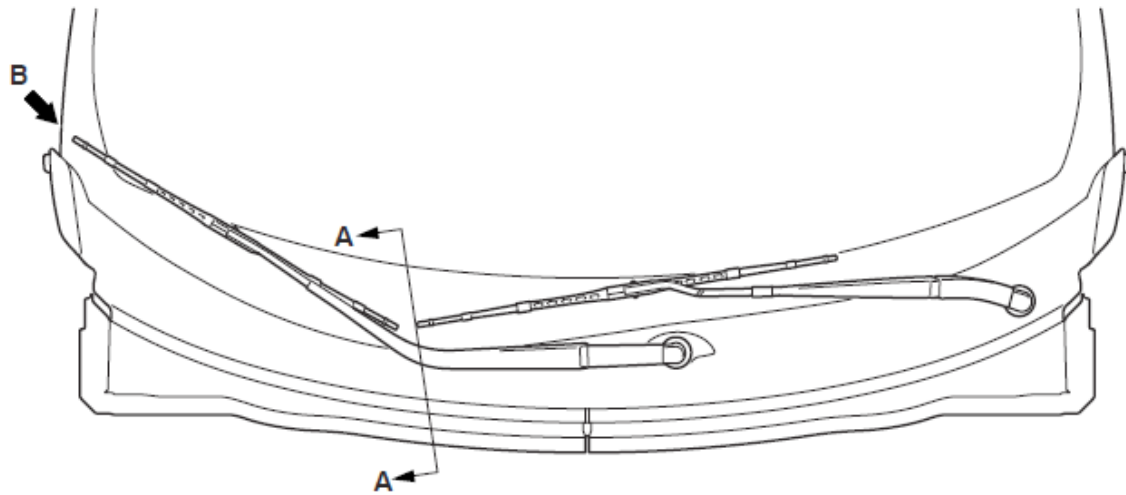

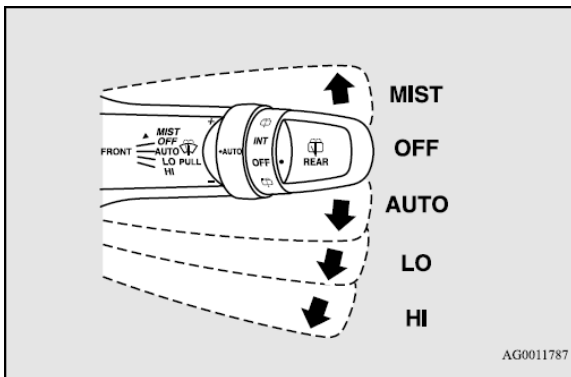

23. Verify wiper motor operation by turning the vehicle ignition to “ACC” or “ON” and activate the windshield wipers in “LO” and “HI” positions.

PARTS INFORMATION

Part Number	Part Description
MW400223	WIPER MOTOR

RECALL CLAIM INFORMATION

There is only 1 possible repair scenario for this campaign.

#	Repair Procedure	Model Years	Campaign Operation	Labor Time
1	Replace Windshield Wiper Motor	2011–2012	C1611Z01	0.6 hours

or

1	Replace Windshield Wiper Motor	2013–2015	C1612Z01	0.6 hours
---	--------------------------------	-----------	----------	-----------

RECALL CAMPAIGN CLAIM INFORMATION

Enter all claims as claim type 'C' – Recall/Campaign Claims.

Please follow the campaign instructions when entering each claim in order to select the applicable operation code that correctly matches up with the work that was actually performed. A claim example is provided below.

Certain 2011–2012 MY Outlander Sport and RVR models (Japan built–JA) and certain 2013–2015 Outlander Sport and RVR models (U.S. built–4A).

Claim Header Section:

MITSUBISHI DEALER LINK Service Warranty Warranty Claim Help

Claim Entry Vehicle Information

Campaign Information

Campaign Operation No: **C1611Z or C1612Z**

Miles/Km: **65500**

VIN: **JA – Japan built
4A - U.S. built**

Service Technician: []

Spec Value * [] Duplicate Recall *

Dealer: 99320 Ref No: [] VIN: []

Claim No: [] Adj: [] Claim Status: Incomplete Model and Year: []

Save & Continue **Main Menu**

Enter in the first 6 characters of the applicable campaign number: **C1611Z if Japan built (VIN starts with JA) or C1612Z if U.S. built (VIN starts with 4A).**

This campaign is for replacing the windshield wiper motor on all involved vehicles.

Check the Open Campaign area of the Superscreen each time to be certain of a vehicle's eligibility. Only VINS showing **C1611Z or C1612Z** as open are involved.

After entering the required customer data, vehicle information, selecting the applicable repair campaign and scenario performed (please note there is only 1 possible repair scenario for this campaign), and then hitting the “Save and Continue” button, the system will automatically fill—in several fields. See the labor and parts examples on the next page.

LABOR:

There is only one possible repair scenario for this campaign.

Scenario 1: C1611Z01 (JA – Japan Built) or C1612Z01 (4A – U.S. Built) 0.6 hours labor.

Replace the windshield wiper motor

PARTS:

Replace the windshield wiper motor (MW400223). No other parts are required.

RENTAL CARS:

If there is a need to provide the owner with a rental car, claim the applicable charges in this section of the claim on the lower portion of the labor entry screen.

Special Sublet Selection				
Select	Labor Operation	Labor Operation Description		Amount
<input type="checkbox"/>	SHO	SPECIAL HANDLING ORDER	SHO Parts Order	
<input type="checkbox"/>	RENTACAR	RENTAL CAR CHARGES 	Days <input type="text"/> Reason <small><Select one></small> <input type="text"/>	
			Rental Company <input type="text"/> Invoice Number <input type="text"/>	
<input type="checkbox"/>	95300040	FREIGHT CHARGES	Freight Company <input type="text"/> Invoice Number <input type="text"/>	
<input type="checkbox"/>	95200040	TOWING CHARGES	Towing Company <input type="text"/> Invoice Number <input type="text"/>	