

Recall Bulletin 161018REV



RECALL BULLETIN:
161018REV

YEAR(S) AFFECTED:
2015-2016

PRODUCT(S) AFFECTED:
Holiday Rambler
Vacationer

MODEL(S) AFFECTED:
All

SUBJECT:
Adding support for the front truss and re-routing wire harnesses and/or hydraulic lines to avoid contact by the front truss

KEYWORDS:
truss, support

ISSUE DATE:
November 2016

The purpose of this recall service bulletin is to provide the instructions for adding additional structural support to correct or prevent the front truss from sagging. A list of affected Holiday Rambler brand Vacationer motorhome serial numbers appears at the end of this Bulletin.

CONDITION:

On motor homes affected by this recall, the front truss may have inadequate support at its attachment points, which could cause it to sag. If wire harnesses or hydraulic lines are routed between the truss and its supporting framework, they could become pinched.

A damaged wire harness can result in an electrical short, which can result in intermittent operation of electrical systems, vehicle “shut down” and/or lead to a fire, and may result in loss of vehicle control, injury or death. Damaged hydraulic lines may cause a hydraulic fluid leak, which may result in fire or personal injury.

CORRECTION:

Follow the steps below to install two new sections of 16 gauge tube steel to support the front truss, and to re-route wire harnesses and a hydraulic line, as necessary to avoid damage. **Contact Dealer Technical Support for assistance and to obtain Prior Authorization for repairs.**

1. Park the motor home on level pavement. Place the transmission in NEUTRAL and set the park brake.
2. Referring to Locations A and B in Figure 1 (page 2), turn the steering wheel all the way to one side, as needed, to gain access to the repair areas.

Note: Use a heavy duty floor jack and heavy duty jack stands if it is necessary to elevate the front of the vehicle to perform repairs.

It may be necessary to remove the front leveling jacks to gain access to the repair area.

3. Turn off the ignition and remove the ignition key.
4. Place wheel chocks under the rear tires to prevent movement.
5. Fabricate two new tube steel supports from 1 1/2” x 1 1/2”, 16 gauge tube steel; each support to be 4” long. They will be used later in the procedure.

This bulletin is supplied for technical information only and is not an authorization for repairs.

Federal Law (Section 154 of the National Traffic and Motor Vehicle Safety Act of 1966) requires that: If you have received a notice of recall or failure to comply from REV Recreation Group or any component manufacturer, you must repair or otherwise correct the defects on vehicles remaining in your inventory, according to the notification, before selling or leasing the vehicles. Any vehicle lessor receiving this recall notice must forward a copy of the notice to the lessee within ten days.

"It is impossible to know, evaluate and advise the service trade of all conceivable ways in which service might be done or of the possible hazardous consequences of each way. Accordingly, anyone who uses a service procedure or tool must first assure that neither personal safety nor vehicle safety will be jeopardized by the selected service methods."

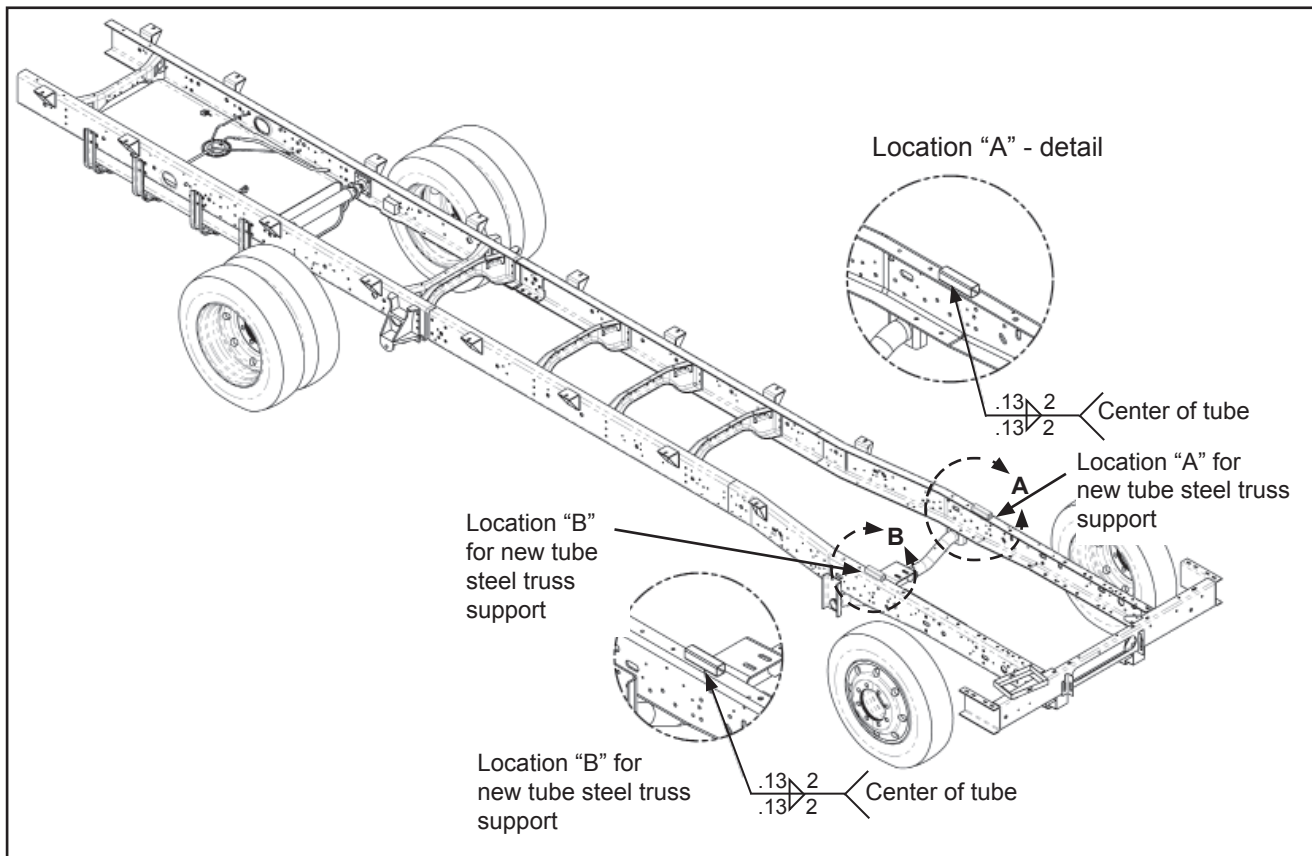

Figure 1

6. From the front wheel well, inspect for the presence of wire harnesses and/or hydraulic lines that may be routed under the front truss, near the frame rail. Refer to Locations A and B in Figure 1.
 - a) If any wire harnesses or hydraulic lines are found damaged, contact REV Dealer Technical Support for instructions and Prior Authorization (PAR) for extended repairs.
 - b) Remove loop clamps and wire ties for wire harnesses or hydraulic lines as necessary to move them away from the repair area while work is performed.

This bulletin is supplied for technical information only and is not an authorization for repairs.

Federal Law (Section 154 of the National Traffic and Motor Vehicle Safety Act of 1966) requires that: If you have received a notice of recall or failure to comply from REV Recreation Group or any component manufacturer, you must repair or otherwise correct the defects on vehicles remaining in your inventory, according to the notification, before selling or leasing the vehicles. Any vehicle lessor receiving this recall notice must forward a copy of the notice to the lessee within ten days.

"It is impossible to know, evaluate and advise the service trade of all conceivable ways in which service might be done or of the possible hazardous consequences of each way. Accordingly, anyone who uses a service procedure or tool must first assure that neither personal safety nor vehicle safety will be jeopardized by the selected service methods."

7. Locate the two “hat-shaped” truss supports and notched sections of angle steel, mounted to the frame rail on each side under the front truss near locations A and B (see Figure 1). Refer also to Figure 2 at right.

To allow room for the installation of two new tube steel support pieces, use a floor jack and a scrap piece of 2” x 4” lumber on the inside frame rail under the front truss and carefully raise the truss upward slightly. On the opposite side of the front truss place a Porta Power spreader jaw attachment between the frame rail and the front truss. Spread the front truss and frame rail to allow room for the installation of a new section of 16 gauge tube steel. See Figures 3 and 4.

Note:

- It may be necessary to reposition the spreader attachment to give sufficient room when installing tube under the truss.

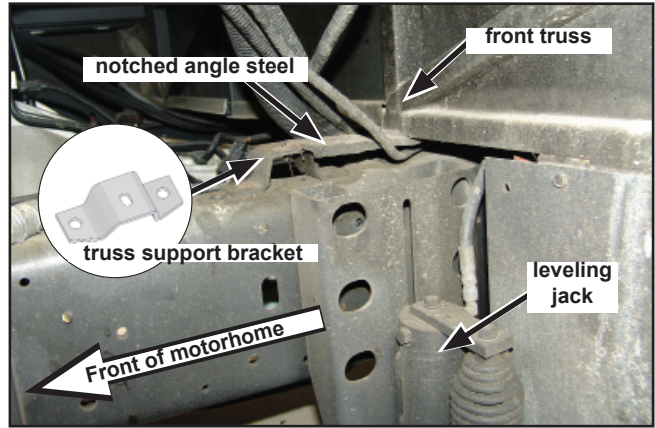

Figure 2 (as viewed from wheel well prior to repairs)

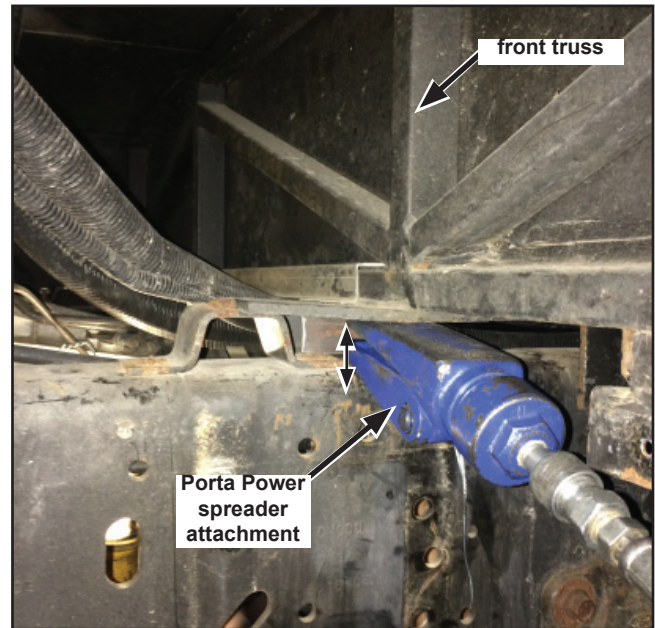

Figure 3



Figure 4

This bulletin is supplied for technical information only and is not an authorization for repairs.

Federal Law (Section 154 of the National Traffic and Motor Vehicle Safety Act of 1966) requires that: If you have received a notice of recall or failure to comply from REV Recreation Group or any component manufacturer, you must repair or otherwise correct the defects on vehicles remaining in your inventory, according to the notification, before selling or leasing the vehicles. Any vehicle lessor receiving this recall notice must forward a copy of the notice to the lessee within ten days.

"It is impossible to know, evaluate and advise the service trade of all conceivable ways in which service might be done or of the possible hazardous consequences of each way. Accordingly, anyone who uses a service procedure or tool must first assure that neither personal safety nor vehicle safety will be jeopardized by the selected service methods."

⚠ WARNING

- Do not weld near combustible materials.
- Wear personal protective equipment while welding.
- Shield electrical or hydraulic lines as necessary prior to welding.
- Disconnect batteries prior to welding.

8. Using isopropyl alcohol and a clean shop cloth, clean and prep the new tube steel support pieces (fabricated in Step 5). Place one of the support pieces under the front truss, just below the junction of its cross-members. Use a MIG welder to put a 2" fillet weld in the approximate center of the tube. Do not weld the front or back edges of the tube. See Figure 5.

Note: If the hat-shaped" truss support and/or notched angle steel is cracked, re-weld the area after adding the tube steel support to this area.



Figure 5

9. Turn the steering wheel all the way to the opposite side to allow access to the opposite side of the front truss. Repeat Steps 7 and 8 for the opposite side (Location B shown in Figure 1). Ensure the truss is supported by both new tube steel supports; correct as necessary.
10. Re-route wire harnesses or hydraulic lines as necessary to avoid future damage by structural components. Secure with loop clamps & nylon wire ties as needed.
11. Clean and prep both newly installed sections of tube steel and coat with black spray paint. See Figure 6.



Figure 6

12. Reinstall the leveling jacks (if removed).
13. **⚠ NOTE: DO NOT PROCEED WITH THIS STEP WITHOUT CALLING REV DEALER TECHNICAL SUPPORT FIRST. CALL TOLL-FREE: (877) 332-9239**
Inspect and if necessary, correct the following:
- Supporting frame members - tighten fasteners as necessary.
 - Front bulkhead to frame rail supports - tighten fasteners as necessary.
 - Bulkhead attachment at the sidewall - secure as necessary.
 - Dash to sidewall attachment - secure as necessary.
14. Remove tools from the repair area. Ensure that no personnel are underneath the vehicle, and then start the engine. Test the operation of the leveling jacks; correct as necessary.

This bulletin is supplied for technical information only and is not an authorization for repairs.

Federal Law (Section 154 of the National Traffic and Motor Vehicle Safety Act of 1966) requires that: If you have received a notice of recall or failure to comply from REV Recreation Group or any component manufacturer, you must repair or otherwise correct the defects on vehicles remaining in your inventory, according to the notification, before selling or leasing the vehicles. Any vehicle lessor receiving this recall notice must forward a copy of the notice to the lessee within ten days.

"It is impossible to know, evaluate and advise the service trade of all conceivable ways in which service might be done or of the possible hazardous consequences of each way. Accordingly, anyone who uses a service procedure or tool must first assure that neither personal safety nor vehicle safety will be jeopardized by the selected service methods."

PARTS

<u>Part number</u>	<u>Description</u>	<u>Qty.</u>
Obtain locally:	16 gauge tube steel, 1 1/2" x 1 1/2" x 4" Nylon wire ties Black Spray Paint Scrap lumber, 2" x 4" x 2-ft.	2 As required

TOOLS

Wheel chocks
Heavy duty floor jack
Heavy duty jack stands
MIG welder
Hydraulic jack kit with spreader jaws (e.g., "Porta Power")
Isopropyl alcohol
Shop cloth

WARRANTY LABOR ALLOWANCE:

Use Flat Rate Code:	Time
6050-12 Recall 161018REV Model Year 2015-2016 Vacationer Truss Support Inspected/Defective/Repaired	8 hours PAR*
6050-11 Recall 161018REV Model Year 2015-2016 Vacationer Truss Support Inspected/Not Defective	0.20 hour PAR*

* Prior Authorization Required

*If you have any questions regarding this Bulletin, contact
REV Recreation Group Dealer Technical Support:*

Monaco/Holiday Rambler Dealer Technical Support: (877) 332-9239

Service literature can be accessed online at: <http://revrvdealers.com>

This bulletin is supplied for technical information only and is not an authorization for repairs.

Federal Law (Section 154 of the National Traffic and Motor Vehicle Safety Act of 1966) requires that: If you have received a notice of recall or failure to comply from REV Recreation Group or any component manufacturer, you must repair or otherwise correct the defects on vehicles remaining in your inventory, according to the notification, before selling or leasing the vehicles. Any vehicle lessor receiving this recall notice must forward a copy of the notice to the lessee within ten days.

"It is impossible to know, evaluate and advise the service trade of all conceivable ways in which service might be done or of the possible hazardous consequences of each way. Accordingly, anyone who uses a service procedure or tool must first assure that neither personal safety nor vehicle safety will be jeopardized by the selected service methods."