



Title: Aerial Trolley Re-enforcement

Date: September 29, 2016

Vehicles: *Predator Panther Aerial, Predator Aerial, Predator SS Aerial, Predator TDA and Predator SS TDA*

VIN Numbers:	8102	1K9AF4286BN058141	8599	1K9AF6487DN058449	8884	1K9AF6481EN058643
	8144	1K9AF4283CN058177	8679	1K9AF4280DN058476	8943	1K9AF6489EN058664
	8147	1K9AF6482BN058159	8691	1K9AF4281DN058504	8945	1K9AF4281EN058648
	8252	1K9AF4283CN058258	8701	1K9AF6486DN058510	9007	1K9AF6485EN058662
	8296	1K9AF4287CN058280	8713	1K9AF6483DN058500	9010	1K9AF4287EN058668
	8327	1K9AF428XCN058273	8724	1K9AF6489DN058517	9065	1K9AF6486EN058671
	8422	1K9AF4289CN058345	8745	1K9AF6481DN058530	9097	1K9AF4285EN058703
	8505	1K9AF4283CN058387	8750	1K9AF428XDN058520	9100	1K9AF4282EN058707
	8506	1K9AF4285CN058388	8751	1K9AF4287EN058606	9255	1K9AF4285FN058802
	8508	1K9AF6486CN058392	8797	1K9AF4281EN058567	9264	1K9AF4281EN058732
	8512	1K9AF4282CN058400	8798	1K9AF4283EN058568	9273	1K9AF6487EN058730
	8531	1K9AF4283DN058410	8799	1K9AF4285EN058569	9316	1K9AF4285EN058748
	8568	1K9AF4283DN058410	8807	1K9AF648XEN058561	9347	1K9AF6489EN058759
	8579	1K9AF6481DN058446	8808	1K9AF6481EN058562	9367	1K9AF4287FN058784
	8584	1K9AF6482DN058472	8809	1K9AF6483EN058563	9368	1K9AF4289FN058785
	8588	1K9AF648XDN058445	8827	1K9AF6484EN058605	9373	1K9AF648XFN058772
	8592	1K9AF4281DN058454	8844	1K9AF6480EN058617	9422	1K9AF648XEN058768
	8597	1K9AF4289DN058444	8878	1K9AF4282EN058626	9482	1K9AF648XFN058822

Problem: Possible separation of the aerial trolley from the fly section of the ladder.

Corrective Action: The installation of re-enforcement inserts to the side clamps of the trolley.

Work Instructions: See the attached drawing.

Parts List: Trolley Guide Kit P/N:95478110

KME CONTACT: Chris Morrison, Warranty Manager

TELEPHONE: 570-669-5577

EMAIL: cmorrison@kmefire.com

MAILING ADDRESS: KME Fire Apparatus
Plant #8
One Industrial Complex
Nesquehoning, PA 18240

ATTENTION: Mr. Chris Morrison

WORK INSTRUCTIONS

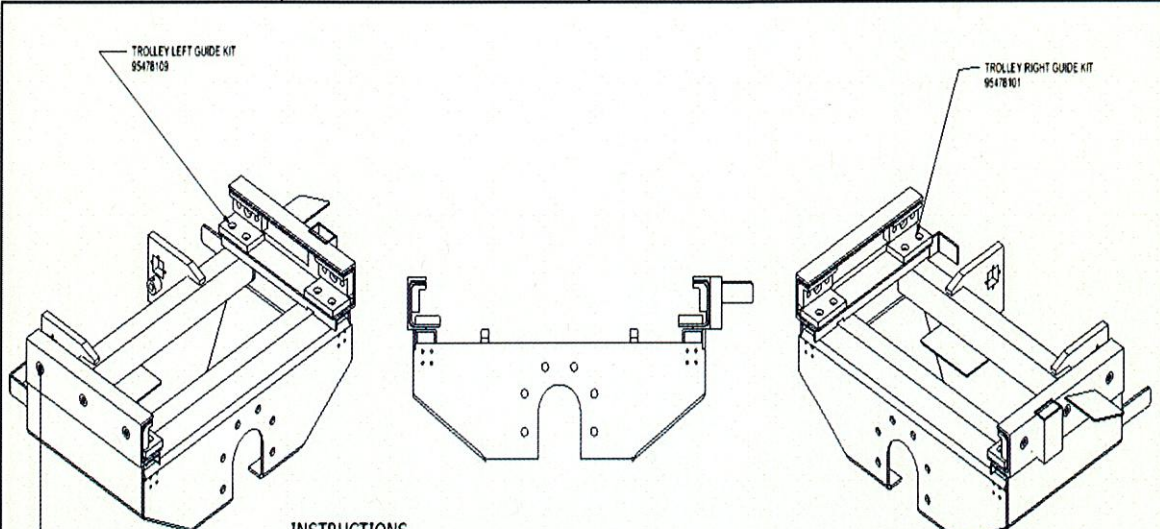

TROLLEY LEFT GUIDE KIT 95478109

TROLLEY RIGHT GUIDE KIT 95478101

BOLT FOR TROLLEY GUIDE PAD THREE (3) PER SIDE

TWO BOLTS LOCATED AT EACH CHANNEL END WILL BE USED TO SECURE THE REPLACEMENT GUIDES. THE CENTER BOLT WILL NOT BE USED FOR THE REPLACEMENT KIT.

INSTRUCTIONS

- o REMOVE THE 3 BOLTS THAT SECURE THE EXISTING GUIDE PAD ON EACH SIDE
- o REMOVE EACH EXISTING SINGLE PIECE SLIDE BY SLIDING OUT ONE END
- o INSTALL THE APPROPRIATE GUIDE ASSEMBLY KIT AND BOLT IN PLACE USING TWO BOLTS PER SIDE THAT WERE USED FOR THE SINGLE PIECE GUIDES
- o CAUTION THE LEFT AND RIGHT GUIDE ASSEMBLIES TO BE INSTALLED AS SHOWN DO NOT REVERSE INSTALL THE LEFT AND RIGHT SIDE ASSEMBLIES

REVIEW ASSEMBLY PHOTOS THAT ARE SUPPLIED. SECURING THE TROLLEY IN PLACE WILL EXPEDITE THE PROCESS.

IF THE ASSEMBLER HAS QUESTIONS THEN CALL KME SERVICE AT 800-819-3573 OR 540-819-3573. PLEASE STATE THE REASON FOR YOUR CALL AS THE TROLLEY KIT INSTALLATION. IF NO ONE IS AVAILABLE THEN YOUR CALL WILL BE RETURNED AS QUICKLY AS SOMEONE CAN BE NOTIFIED.

MATERIAL: SEE BOM	DRAWN BY: J CURRIN	DATE: 2/10/2015	KME FIRE APPARATUS	
TITLE: TROLLEY GUIDE KITS	DWG/PART NO: 95478110	REV.	SHT. 1	

WORK INSTRUCTIONS
(CONTINUED)

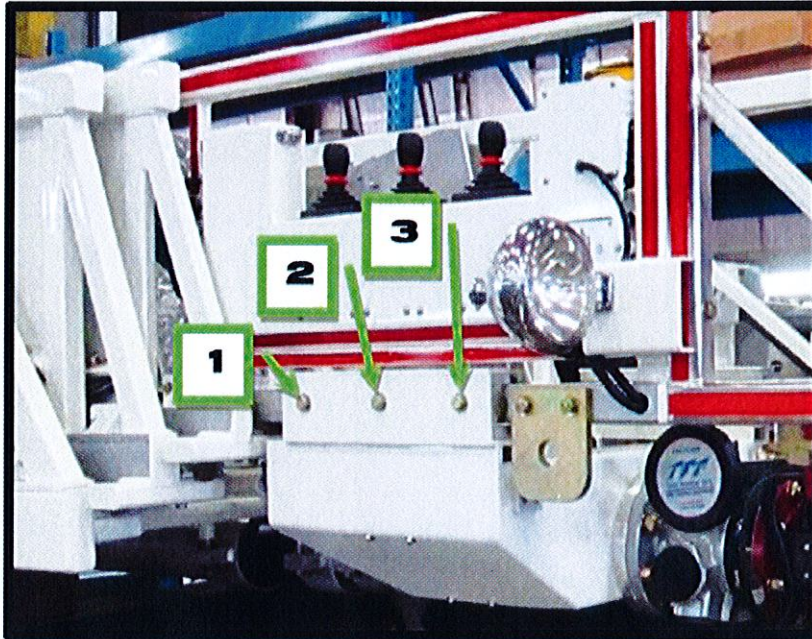

Figure 1 Remove 3 Screws on Each Side