



# SAFETY RECALL BULLETIN

## NHTSA RECALL 16V723, Transport Canada 2016-504

AUTOCAR INDUSTRIES, LLC SAFETY RECALL MDTT-1602 REV. 001

October, 2016

### Attention:

Service Managers/Parts Managers

### Subject:

Autocar has determined that a safety defect exists in the steering linkage assembly of certain 2015-2017 model-year Xspotters and Xperts.

### Safety Recall Information:

This document contains information regarding the correction of torque values on the castle nuts of the steering assembly.

### Vehicles Affected:

There are 1,132 affected units assembled after March 2, 2015. Refer to the VIN list beginning on page 8.

### Service Responsibility:

Service sites must perform this recall on affected vehicles at no charge to the owner regardless of vehicle mileage, age or ownership. If a vehicle affected by this recall is taken into or is currently in your vehicle inventory at your center for service, you must perform this recall before the vehicle is sold or released to the owner.

### Required Parts:

Replacement cotter pins (obtain locally)

### Claims for Reimbursement:

Submit a claim for reimbursement in accordance with Autocar's Warranty Administration Manual.

### Claim Coding Information

(Xpert)

Labor Operation Code Number	Time Allowance SRT	Description
61201-0-03	1.00 HR	Correction of Torque of Castle Nuts

### Claim Coding Information

(Xspotter)

Labor Operation Code Number	Time Allowance SRT	Description
11.17.1	1.00 HR	Correction of Torque of Castle Nuts

### Tools Required:

1/2" Drive Ratchet

1 5/16" 1/2" Drive Socket

250 Foot Pound Torque Wrench

6" Slip-Joint Pliers (For installing cotter pins)

# SAFETY RECALL BULLETIN

NHTSA RECALL 16V723, Transport Canada 2016-504

AUTOCAR INDUSTRIES, LLC SAFETY RECALL MDTT-1602 REV. 001

October, 2016

## Safety Notices:



### WARNING

Allow the vehicle's engine and cooling system to cool to ambient temperature before performing the repair procedure. A hot engine or cooling assembly may cause burns or other personal injury.



### WARNING

To prevent eye injury, always wear eye protection when performing vehicle maintenance, service or inspection.



### WARNING

Before working on a vehicle, set the parking brake, place the transmission in neutral and block the wheels. Failure to do so can result in unexpected vehicle movement and can cause serious personal injury or death.



### WARNING

Due to the danger of sustaining personal injury and/or damage to the vehicle, never attempt to raise the cab outdoors under extremely windy conditions. Strong wind conditions could force the cab beyond the normal limits of its travel. Never rely on the hydraulic pressure to hold the cab in an open position. Always use the safety pin in the cab tilt lock tube to prevent serious personal injury or death.



### WARNING

Remove or secure all loose articles and close all doors before raising the cab. The area above and ahead of the cab must be clear from obstructions. Place front wheels in a straight ahead position.

Remove the pump handle from its storage on the inside of the cab near the driver or passenger seat.

Place the selector lever on the hydraulic pump in the RAISE position. Insert the pump handle into the pump and operate the handle in an up and down motion.

The hydraulic cab latches will open, then the hydraulic cylinders will lift the cab until the midpoint (top) is reached. Once the cab has reached its midpoint the cab will move forward to the fully open position. The safety pin in the cab tilt lock device must be installed when the holes line up in the sliding bar.

Remove the pump handle when not in use. It may stick out and could cause injury to passersby.



# SAFETY RECALL BULLETIN

## NHTSA RECALL 16V723, Transport Canada 2016-504

### AUTOCAR INDUSTRIES, LLC SAFETY RECALL MDTT-1602 REV. 001

October, 2016



## CAUTION

### LOCKOUT/TAGOUT PROCEDURES:

Before entering the vehicle or vehicle body, read and follow OSHA regulations concerning entry and working in “CONFINED SPACE” OSHA 1910.146 and “LOCKOUT/TAGOUT” OSHA 1910.147. Follow OSHA regulations while performing any work on the vehicle. The vehicle must be disabled by the following steps before performing any work on the vehicle:

1. Place the transmission in NEUTRAL.
2. Set the parking brake.
3. Shut the engine OFF.
4. Lock cab doors, keep the key in your pocket. Block the wheels before entering the body or performing any work on the vehicle.
5. Turn the battery disconnect switch OFF, if equipped.
6. Completely drain the air from the primary/A system and secondary/B system by opening the drain valves on the air tanks themselves or by using the drain manifold if supplied. When draining the air tanks, do not look into the area where air is draining. Dirt or sludge particles may be expelled in the air stream and can cause eye injury.
7. Place magnetic “DANGER” signs on both cab doors before entering the body or performing any work on the vehicle.

8. Take proper precautions before working under the vehicle. Use ramps approved for the weight of your vehicle, or use floor jacks and stands. Never work under a vehicle supported by jacks alone. Always use jack stands to support the vehicle.



## WARNING

**Autocar natural gas powered vehicles require specific compliance in the service, storage and refueling procedures.**

**If you store or dispense Compressed Natural Gas (CNG) or Liquid Natural Gas (LNG), or if you work on CNG or LNG trucks, your location must be fully compliant with applicable codes, regulations and standards, including National Fire Protection Association (NFPA) codes, Society of Automotive Engineers (SAE) standards, American National Standards Institute (ANSI), Natural Gas Vehicle (NGV) standards, the United States Code of Federal Regulations (CFR), and your state and local fire and other applicable codes (including the California Code of Regulations and the Texas Administrative Code, as applicable). Contact your local fire department for guidance and additional compliance information. Technicians working on Autocar trucks with CNG or LNG engines must be trained in the proper repair of CNG and LNG engines and the safe storage and dispensing of CNG and LNG.**

# SAFETY RECALL BULLETIN

## NHTSA RECALL 16V723, Transport Canada 2016-504

AUTOCAR INDUSTRIES, LLC SAFETY RECALL MDTT-1602 REV. 001

October, 2016

### CORRECTION OF TORQUE VALUES ON CASTLE NUTS OF STEERING ASSEMBLY

1. Raise the cab. Refer to the Safety Notices on page 2. Make sure that you read and understand the safety precautions before proceeding.
2. Locate the castle nuts on the drag link. Remove the cotter pins and discard (See Figure 1 for Single Drive Xpert, Figure 2 for Dual Drive Xpert or Figure 3 for Xspotter).

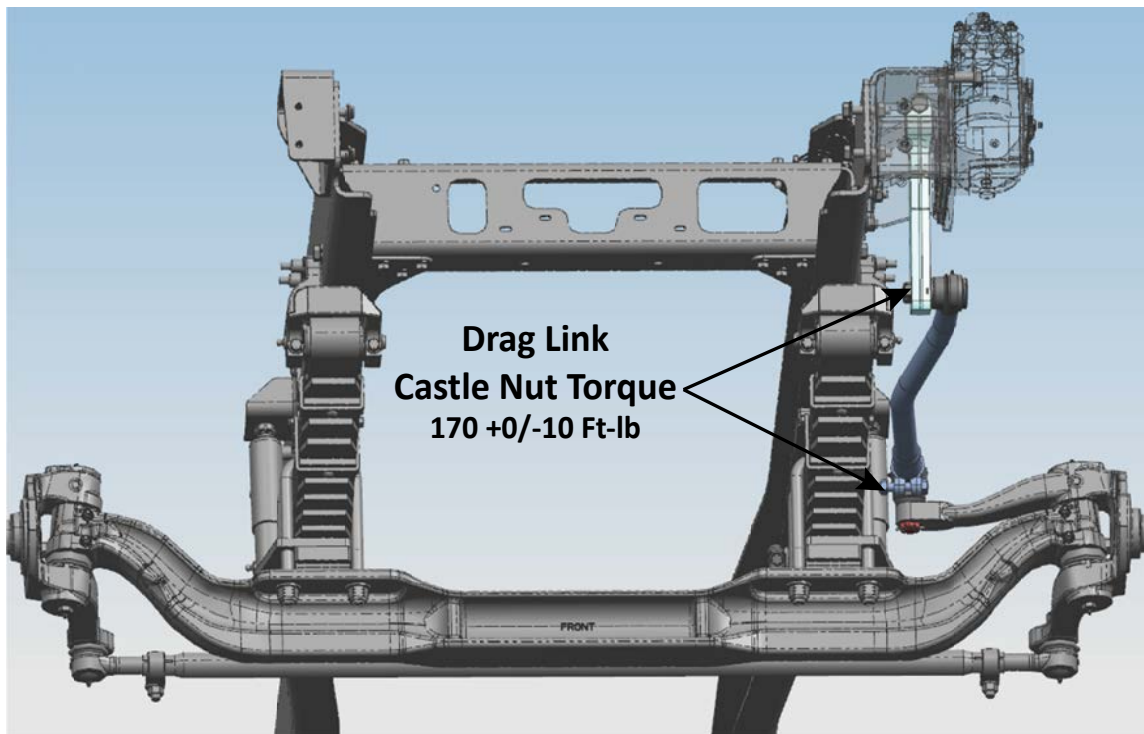

**Figure 1**  
**Single Drive Xpert**

# SAFETY RECALL BULLETIN

NHTSA RECALL 16V723, Transport Canada 2016-504

AUTOCAR INDUSTRIES, LLC SAFETY RECALL MDTT-1602 REV. 001

October, 2016

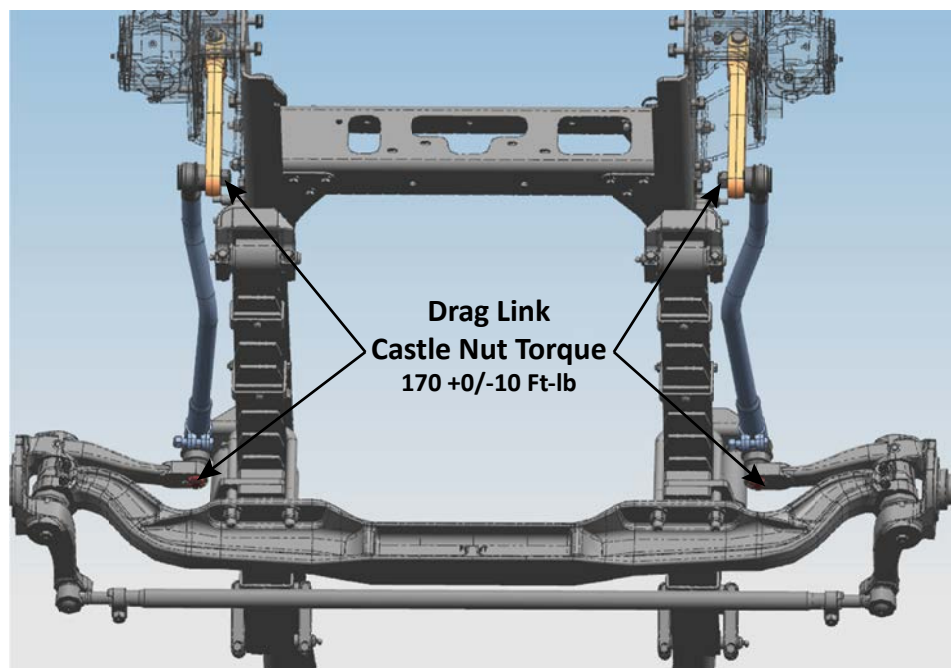

**Figure 2**  
**Dual Drive Xpert**

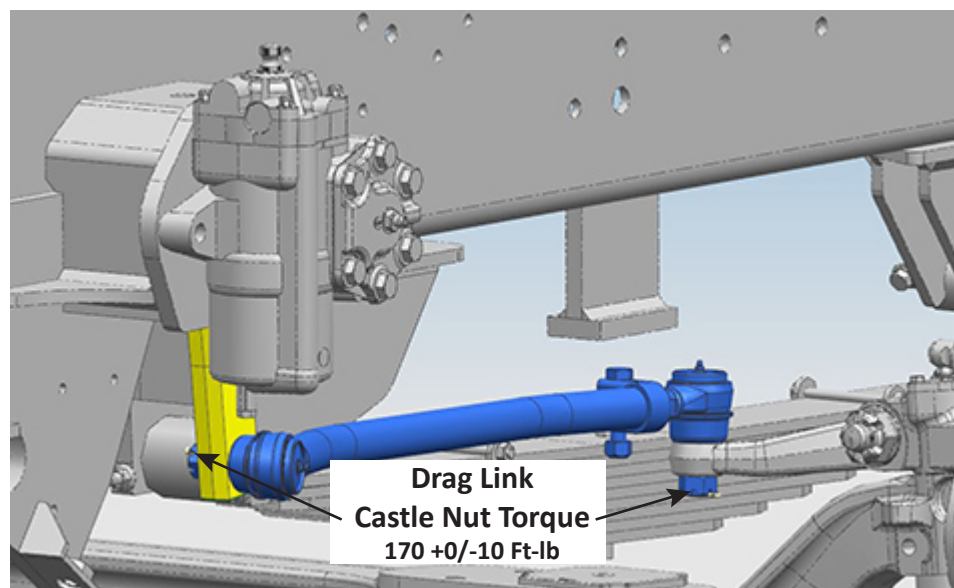

**Figure 3**  
**Xspotter**



# SAFETY RECALL BULLETIN

## NHTSA RECALL 16V723, Transport Canada 2016-504

AUTOCAR INDUSTRIES, LLC SAFETY RECALL MDTT-1602 REV. 001

October, 2016

3. Un-screw the castle nut by rotating it counter-clockwise until the castle nut turns freely. Using hand force only, check for any movement of the tapered stud within the steering arm/pitman arm. Inspect each tapered stud (See Figure 4). If there are any signs wear or fretting on the contact surface between the castle nut and the steering arm/pitman arm, or if there are any signs of loose fit or movement or rotation within the steering arm or pitman arm, or if the nut will not tighten to the specified torque (See Torque Chart below), call Autocar technical support at 888-218-3611.

4. Torque each castle nut to the specified torque in the Torque Chart below.

**Note:** *Tighten all castle nuts to torque specified in chart. If the cotter pin hole is not visible, increase torque until hole is visible.*

Torque Chart				
Component	Thread Size	Socket Size	Ft-lb	+/-
Drag Link Castle Nut	7/8"-14	1 5/16"	170	0/10

5. Install a new cotter pin through the hole and bend one leg toward the back of the castle nut and the other up around the end of the threaded fastener (See Figure 4).

6. Repeat step 2 through step 5 until all the castle nuts in the steering assembly have been re-torqued.

# SAFETY RECALL BULLETIN

## NHTSA RECALL 16V723, Transport Canada 2016-504

### AUTOCAR INDUSTRIES, LLC SAFETY RECALL MDTT-1602 REV. 001

October, 2016

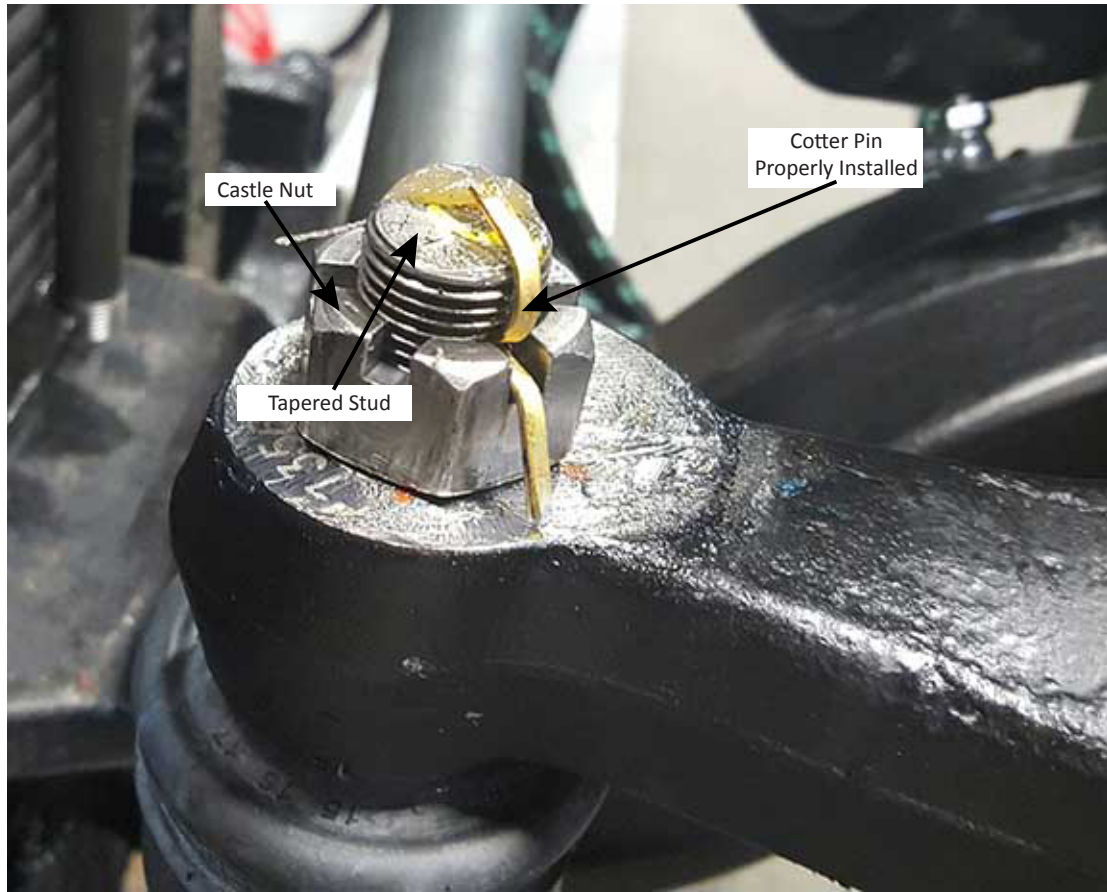

**Figure 4**

- 7. Lower the cab. Refer to the safety notes on page 2.
- 8. The procedure is complete.