

Safety Recall

Code: 48M5



Subject	Steering Rack
Release Date	September 27, 2016
Affected Vehicles	U.S.A.: MY 2017 Audi Q7 <i>Check Campaigns/Actions screen in Elsa on the day of repair to verify that a VIN qualifies for repair under this action. Elsa is the <u>only</u> valid campaign inquiry & verification source.</i> <ul style="list-style-type: none">✓ Campaign status must show "open."✓ If Elsa shows other open action(s), inform your customer so that the work can also be completed at the same time the vehicle is in the workshop for this campaign.
Problem Description	Silicone gel used to protect a circuit board within the steering rack control unit does not harden according to factory specifications. Because of this, the circuit board is not protected against particles that may enter the area, and can lead to a short circuit and loss of power steering assist. If a vehicle experiences a loss of power steering assist, extra steering effort will be required at lower speeds, increasing the risk of a vehicle crash.
Corrective Action	Replace the steering rack.
Precautions	If a power steering indicator light or message appears in the instrument panel, and if the vehicle experiences a loss of power steering assist, immediately contact an authorized Audi dealer to have the vehicle inspected. Refer to the owner's manual for information on vehicle indicator lights and messages.
Parts Information	Because there are only eight (8) vehicles in the United States affected by this recall, there will be no parts allocation. If parts are needed to support a scheduled vehicle repair, submit your request with VIN via email to vwoaspecialservices@vw.com .
Code Visibility	On or about September 27, 2016, affected vehicles will be listed on the Inventory Vehicle Open Campaign Action report under My Dealership Reports (found on www.accessaudi.com & OMD Web). A list will not be posted for dealers who do not have any affected vehicles. On or about September 27, 2016, this campaign code will show open on affected vehicles in Elsa. On or about September 27, 2016, affected vehicles will be identified with this campaign code in the VIN Lookup tool at www.audiusa.com and on the NHTSA VIN lookup tool at www.safercar.gov .
Owner Notification	Owner notification is expected to begin in October 2016. An owner letter example is included in this bulletin for your reference.
Additional Information	Please alert everyone in your dealership about this action, including Sales, Service, Parts and Accounting personnel. Contact Warranty if you have any questions. IMPORTANT REMINDER ON VEHICLES AFFECTED BY SAFETY & COMPLIANCE RECALLS <u>New Vehicles in Dealer Inventory:</u> It is a violation of Federal law for a dealer to deliver a new motor vehicle or any new or used item of motor vehicle equipment (including a tire) covered by this notification under a sale or lease until the defect or noncompliance is remedied. By law, dealers must correct, prior to delivery for sale or lease, any vehicle that fails to comply

with an applicable Federal Motor Vehicle Safety Standard or that contains a defect relating to motor vehicle safety.

Pre-Owned Vehicles in Dealer Inventory: Dealers should not deliver any pre-owned vehicles in their inventory which are involved in a safety or compliance recall until the defect has been remedied.

Dealers must ensure that every affected inventory vehicle has this campaign completed before delivery to consumers.

Claim Entry Instructions

After campaign has been completed, enter claim as soon as possible to help prevent work from being duplicated elsewhere. Attach the Elsa screen print showing action open on the day of repair to the repair order.

If customer refused campaign work:

- ✓ U.S. dealers: Submit the request through Audi Warranty Online under the Campaigns/Update option.

Service Number	48M5																												
Damage Code	0099																												
Parts Vendor Code	002																												
Claim Type	Sold vehicle: 7 10 Unsold vehicle: 7 90																												
Causal Indicator	Mark steering rack as causal part*																												
Vehicle Wash/Loaner	Do not claim wash/loaner under this action																												
Criteria I.D.	4M																												
	Replace steering rack Labor operation: 4835 23 99 280 T.U.																												
	<table border="1"> <thead> <tr> <th>Quantity</th> <th>Part Number</th> <th>Description</th> </tr> </thead> <tbody> <tr> <td>1.00</td> <td>4M1423055N</td> <td>Steering rack*</td> </tr> <tr> <td>4.00</td> <td>N 91151101</td> <td>Hexagon bolt</td> </tr> <tr> <td>2.00</td> <td>WHT005372</td> <td>Socket head bolt</td> </tr> <tr> <td>2.00</td> <td>WHT006151</td> <td>Nut</td> </tr> <tr> <td>2.00</td> <td>WHT006662</td> <td>Hexagon bolt</td> </tr> <tr> <td>2.00</td> <td>WHT002305</td> <td>Square nut</td> </tr> <tr> <td>1.00</td> <td>N 10518405</td> <td>Socket head bolt</td> </tr> <tr> <td>4.00</td> <td>N 91240101</td> <td>Nut</td> </tr> </tbody> </table>		Quantity	Part Number	Description	1.00	4M1423055N	Steering rack*	4.00	N 91151101	Hexagon bolt	2.00	WHT005372	Socket head bolt	2.00	WHT006151	Nut	2.00	WHT006662	Hexagon bolt	2.00	WHT002305	Square nut	1.00	N 10518405	Socket head bolt	4.00	N 91240101	Nut
Quantity	Part Number	Description																											
1.00	4M1423055N	Steering rack*																											
4.00	N 91151101	Hexagon bolt																											
2.00	WHT005372	Socket head bolt																											
2.00	WHT006151	Nut																											
2.00	WHT006662	Hexagon bolt																											
2.00	WHT002305	Square nut																											
1.00	N 10518405	Socket head bolt																											
4.00	N 91240101	Nut																											

The repair information in this document is intended for use only by skilled technicians who have the proper tools, equipment and training to correctly and safely maintain your vehicle. These procedures are not intended to be attempted by "do-it-yourselfers," and you should not assume this document applies to your vehicle, or that your vehicle has the condition described. To determine whether this information applies, contact an authorized Audi dealer. ©2016 Audi of America, Inc. All Rights Reserved.

Customer Letter Example (USA)

<MONTH YEAR>

<CUSTOMER NAME>

<CUSTOMER ADDRESS>

<CUSTOMER CITY STATE ZIPCODE>

This notice applies to your vehicle: <VIN>

NHTSA: <INSERT NUMBER>

**Subject: Safety Recall 48M5 – Steering Rack
2017 Model Year Audi Q7**

Dear Audi Owner,

This notice is sent to you in accordance with the National Traffic and Motor Vehicle Safety Act. Audi has decided that a defect, which relates to motor vehicle safety, exists in certain MY 2017 Audi Q7 vehicles. Our records show that you are the owner of a vehicle affected by this action.

- What is the issue?** Silicone gel used to protect a circuit board within the steering rack control unit does not harden according to factory specifications. Because of this, the circuit board is not protected against particles that may enter the area, and can lead to a short circuit and loss of power steering assist. If a vehicle experiences a loss of power steering assist, extra steering effort will be required at lower speeds, increasing the risk of a vehicle crash.
- What will we do?** To help correct this defect, your authorized Audi dealer will replace the steering rack in affected vehicles. This work will take about three hours to complete and will be performed for you free of charge.
- What should you do?** Please contact your authorized Audi dealer without delay to schedule this recall repair. For your convenience, you can also visit www.audiusa.com and click on the “Find a Dealer” link to locate a dealer near you and schedule this service.
- Precautions you should take** If a power steering indicator light or message appears in the instrument panel, and if the vehicle experiences a loss of power steering assist, immediately contact an authorized Audi dealer to have the vehicle inspected. Refer to the owner’s manual for information on vehicle indicator lights and messages.
- Lease vehicles and address changes** If you are the lessor and registered owner of the vehicle identified in this action, the law requires you to forward this letter immediately via first-class mail to the lessee within ten (10) days of receipt. If you have changed your address or sold the vehicle, please fill out the enclosed prepaid Owner Reply card and mail it to us so we can update our records.
- Reimbursement of Expenses** If you have previously paid for repairs relating to the condition described in this letter, the enclosed form explains how to request reimbursement. We would be pleased to review your reimbursement request.
- Can we assist you further?** If your authorized Audi dealer fails or is unable to complete this work free of charge within a reasonable time, please contact Audi Customer Experience at 1-800-253-2834 or via our “Contact Us” page at www.audiusa.com.
- Checking your vehicle for open Recalls and Service Campaigns** To check your vehicle’s eligibility for repair under this or any other recall/service campaign, please visit the **Recall/Service Campaign Lookup** tool at www.audiusa.com and enter your Vehicle Identification Number (VIN).

If you still cannot obtain satisfaction, you may file a complaint with: The Administrator, National Highway Traffic Safety Administration, 1200 New Jersey Avenue, SE., Washington, DC 20590; or call the toll-free Vehicle Safety Hotline at 1-888-327-4236 (TTY: 1-800-424-9153); or go to <http://www.safercar.gov>.

We apologize for any inconvenience this matter may cause; however we are taking this action to help ensure your safety and continued satisfaction with your vehicle. Thank you for your continued loyalty!

Sincerely,

Audi Customer Protection

NOTE

Damages resulting from improper repair or failure to follow these work instructions are the dealer's responsibility and are not eligible for reimbursement under this action.

Required Parts

Part Description	Part Number	Quantity
Steering rack	4M1 423 055 N	1
Hexagon bolt	N 911 511 01	4
Socket head bolt	WHT 005 372	2
Nut	WHT 006 151	2
Hexagon bolt	WHT 006 662	2
Square nut	WHT 002 305	2
Socket head bolt	N 105 184 05	1
Nut	N 912 401 01	4

Required Tools

V.A.G 1331



W00-0427

- Torque Wrench 1331 5-50Nm -VAG1331- (or equivalent)

V.A.G 1332



W00-0428

- Torque Wrench 1332 40-200Nm -VAG1332- (or equivalent)

VAS6931



- Engine and Gearbox Jack -VAS6931-

VAS 251 805



- Ball Joint Splitter -VAS251 805- (or equivalent)

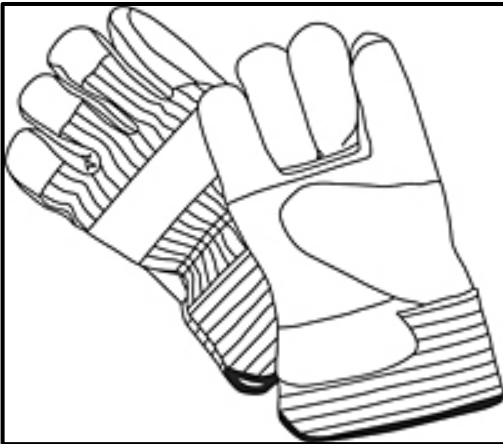

- Safety Gloves (or equivalent)

V.A.G 1332/7

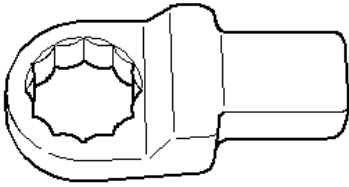

W00-10096

- Torque Wrench 1332 Insert - Ring Wrench - 21mm -VAG1332/7



- VAS6150D - Diagnostic Tester
- VAS6154 - Vehicle Communication Interface



- GRX3000VAS – Battery Tester/Charger (or equivalent)

Repair Instruction

Section A - Check for Previous Repair

Applicable criteria ID(s)	Campaign/Action Status
01 ← 2	Open ← 1

EXAMPLE

- Enter the VIN in Elsa and proceed to the “Campaign/Action” screen.

TIP

On the date of repair, print this screen and keep a copy with the repair order.

- Confirm the Campaign/Action is open <arrow 1>. If the status is closed, no further work is required.
- Note the Applicable Criteria ID <arrow 2> for use in determining the correct work to be done and corresponding parts associated.

Proceed to Section B

Section B – Repair Procedure

- Bring wheels to the straight-ahead position.
- Switch off the ignition.



NOTE

- Use adhesive tape, which can be removed without leaving any adhesive residue.
- Be careful not to turn the steering wheel during the repair because the clock spring - F138- can become damaged.
- Secure the steering wheel in the straight-ahead position using tape so that it does not turn unintentionally <arrow>.
- Remove the front wheels.

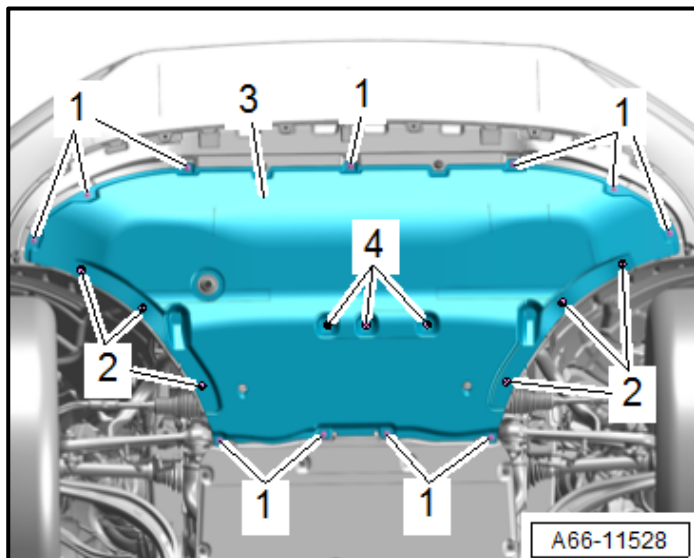

- Remove the front noise insulation bolts <1, 2 and 4>.
- Remove the front noise insulation <3>.

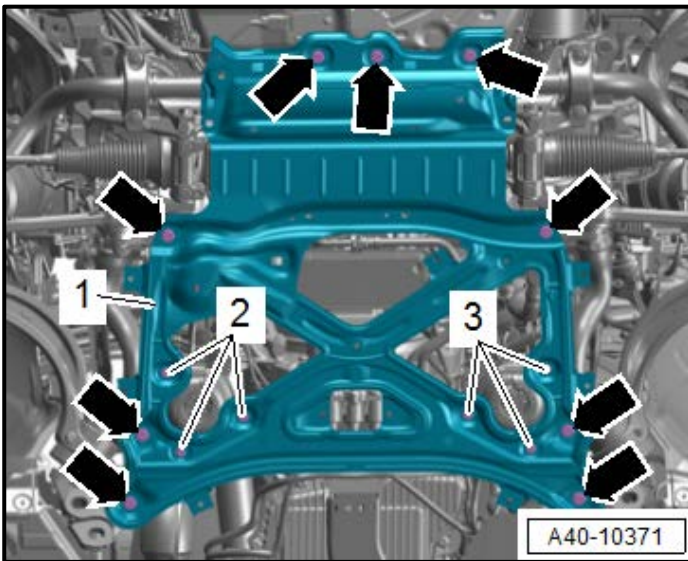

Equipment Versions with Side Transmission Mount:

- Remove the bolts <2 and 3>.

Equipment Versions without Sway Stabilization:

- Remove the bolts <arrows> and the subframe crossbrace <1>.

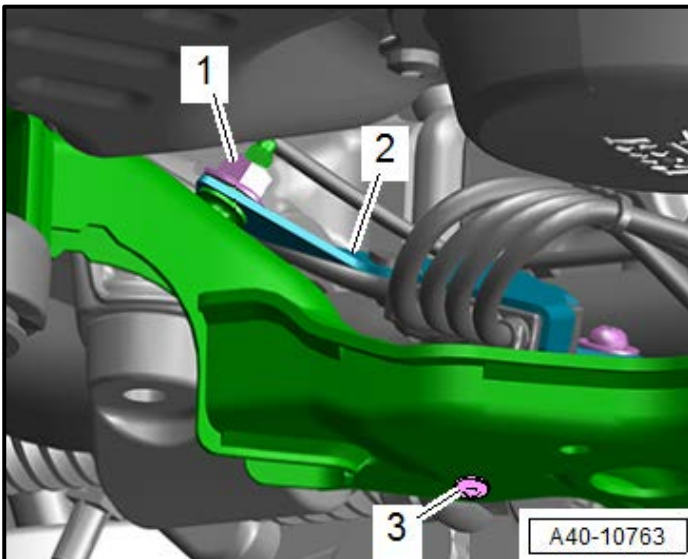

Equipment versions with Sway Stabilization:

- Remove the nut <1> and bolt <3>, and free up the bracket <2> with the wires.

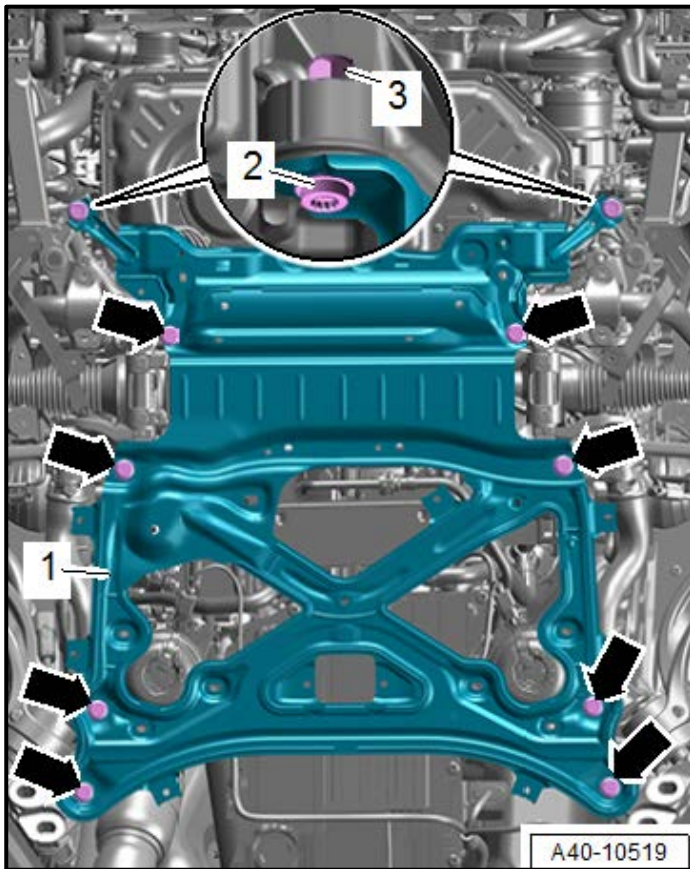

- Counter-hold the nut <3> and remove the left and right bolt <2>.
- Remove the bolts <arrows> and the subframe crossbrace <1>.

! NOTE

Risk of damaging the suspension components.

- If the subframe mount, steering rack or subframe crossbrace are not installed correctly, do not rest the vehicle on its wheels.
- Supporting the vehicle at the subframe or the subframe crossbrace (for example, using a floor jack or similar device) is not permitted.
- If the vehicle must be moved, install the crossbrace for the subframe and tighten the old bolts to the tightening specification without an additional turn.

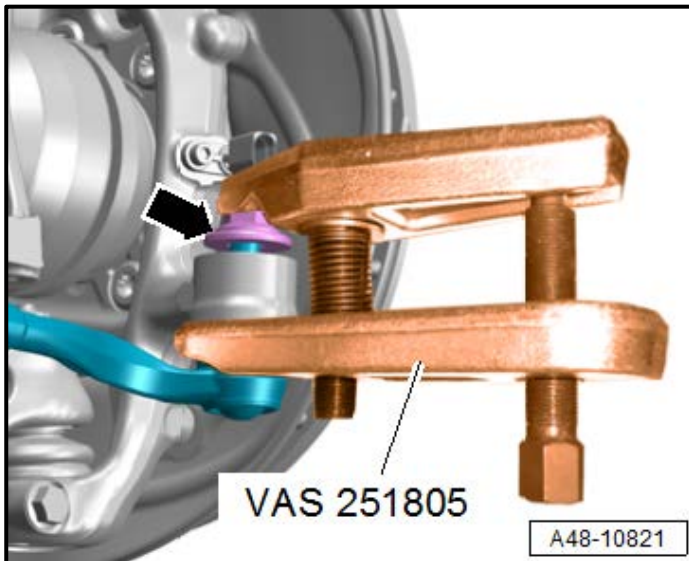

Continuation for All Vehicles:

- To protect the threads, remove the nut <arrow> from the tie rod end joint pin until it is flush with the joint pin threads.

⚠ WARNING

Risk of injury from falling components.

When pressing off, the tie rod end loosens abruptly from the wheel bearing housing. Use, for example, the -VAS6931- to secure.

ⓘ NOTE

Risk of damaging the ball joint puller.

Make sure that both puller lever arms are parallel to each other when using maximum force.

- Remove the tie rod end with the -VAS251805- from the wheel bearing housing.
- Then remove the nut. Use a 6 mm inner hex socket to counter-hold at the joint pin if necessary.
- Remove the adhesive residue from the pin threads after removing.
- Repeat the procedure on the other side of the vehicle.
- Measure the dimension <a> between the tie rod head <1> and the left and right tie rod <2> and make a note of the value.

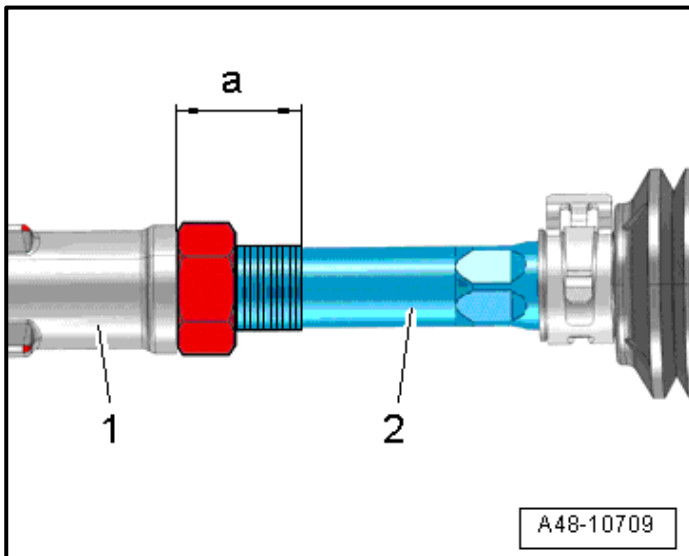

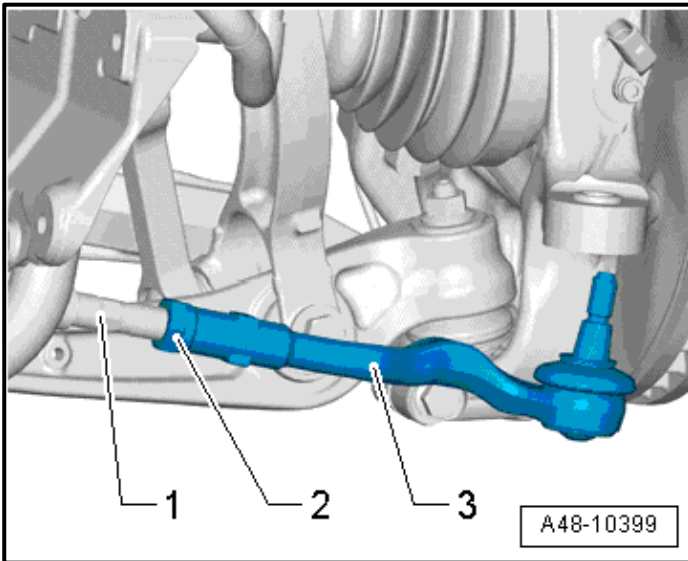

- Only loosen the nut <2> while counter-holding the tie rod end <3>.
- Remove the tie rod end, while counter-holding at the tie rod hex fitting <1> if necessary.

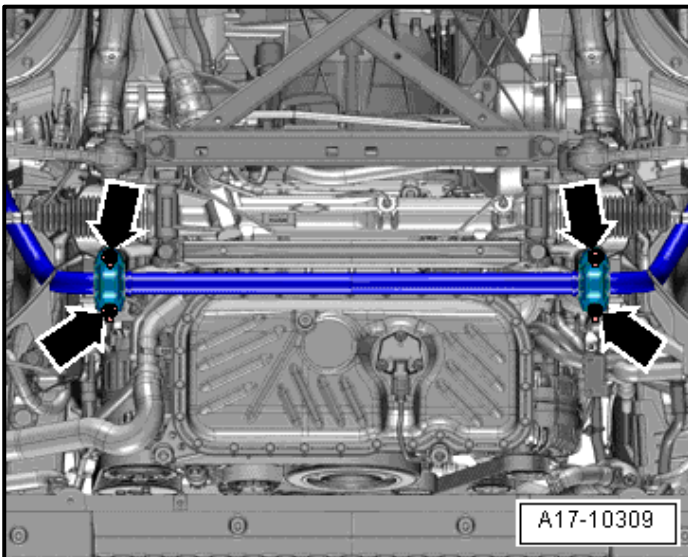

- Remove the nuts <arrows> evenly alternating from side to side and tie up the stabilizer bar.

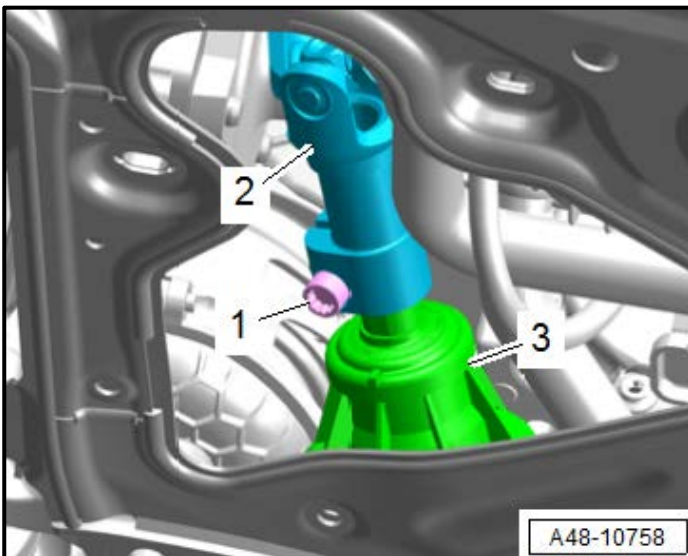

- Remove and discard the bolt <1>.
- Remove the universal joint <2> of the steering intermediate shaft from the steering rack <3>.

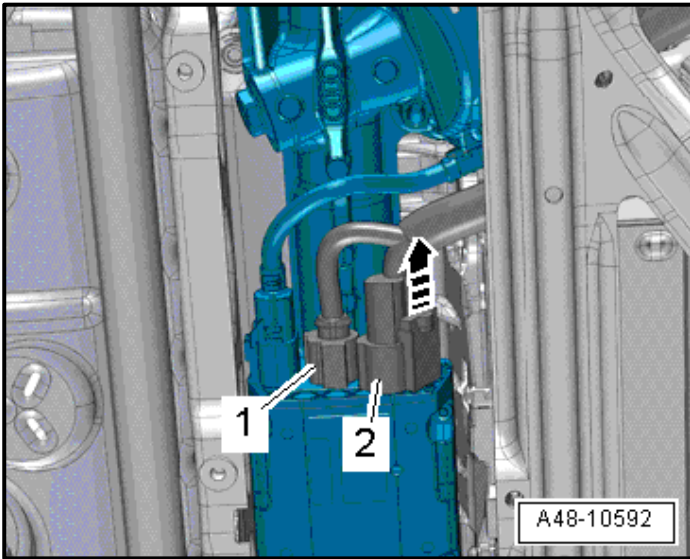

- Release the safety catch, push the retainer down and disconnect the connectors <1 and 2> from the Power Steering Control Module - J500-.

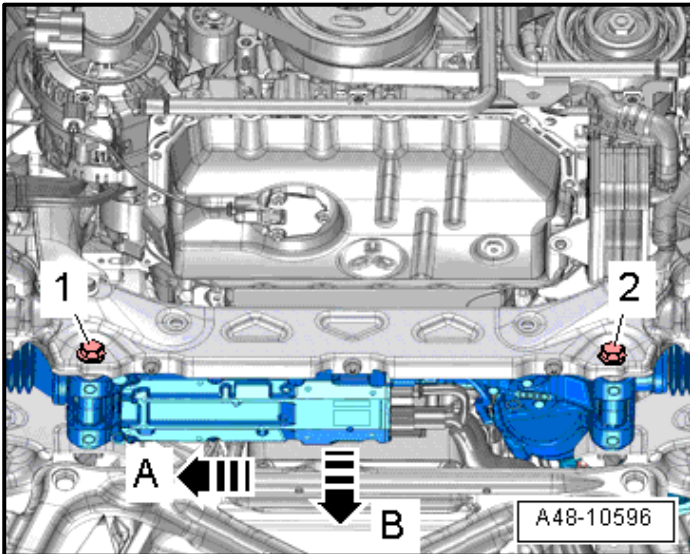

NOTE

Risk of damaging the boots.

The steering rack must not contact the boots during removal.

- Remove and discard the bolts <1 and 2> and the square nuts.
- Push the steering rack slightly to the side <arrow A> and remove it downward <arrow B>.

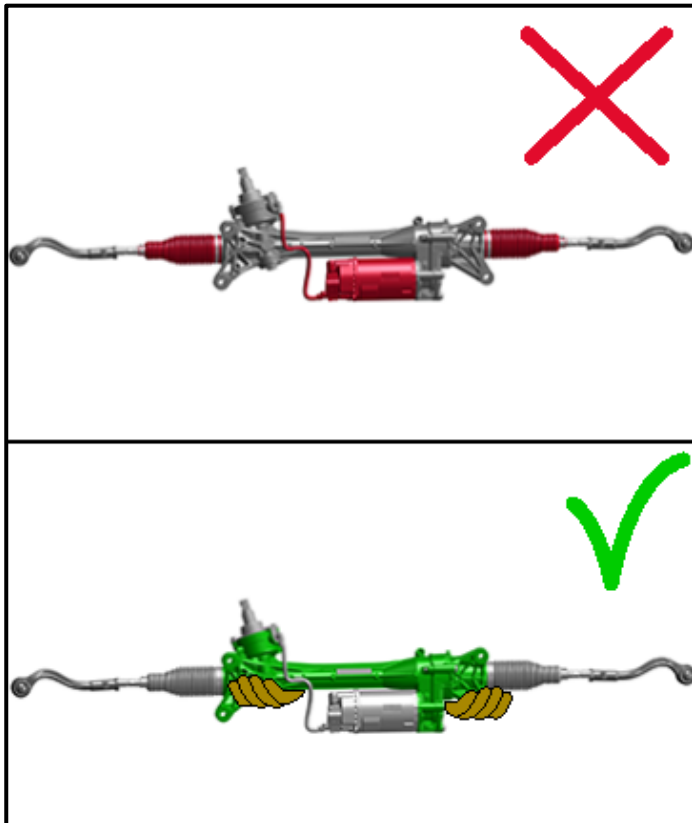

⚠ WARNING

Damage to the steering rack poses a safety risk.
The steering rack must always be handled correctly.

! NOTE

Transporting at the components colored in “red” causes damage to the steering rack.

- Boot: damaged when pressed, grabbed, or placed on hard surfaces.
- Motor: treating harshly or placing on hard surfaces may damage the connectors and/or wires.

The steering rack must not be under any mechanical load.

- A steering rack that has fallen onto a hard surface or shows any sign of damage must not be installed in the vehicle

Steering Rack, Handling And Transporting Correctly

- Transport the steering rack using both hands.
- Only grab the steering rack at the areas colored in “green”.

- Position the new steering rack <1> into place on the vehicle.

Part Number	Part Description	Qty.
4M1 423 055 N	Steering rack	1

- Install both new bolts <2> and both new square nuts <3> loosely, then tighten to 80 Nm + 180°.

Part Number	Part Description	Qty.
WHT 006 662	Hexagon bolt	2
WHT 002 305	Square nut	2

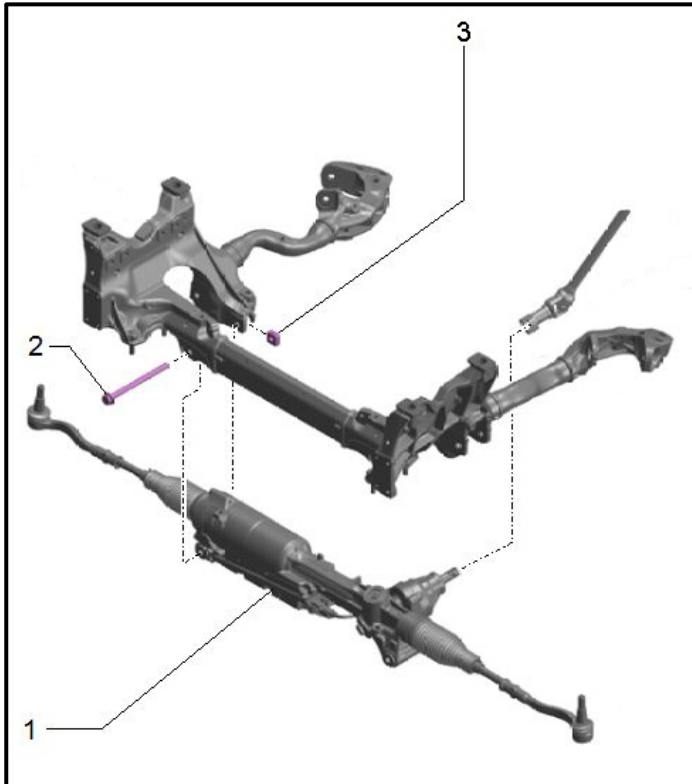

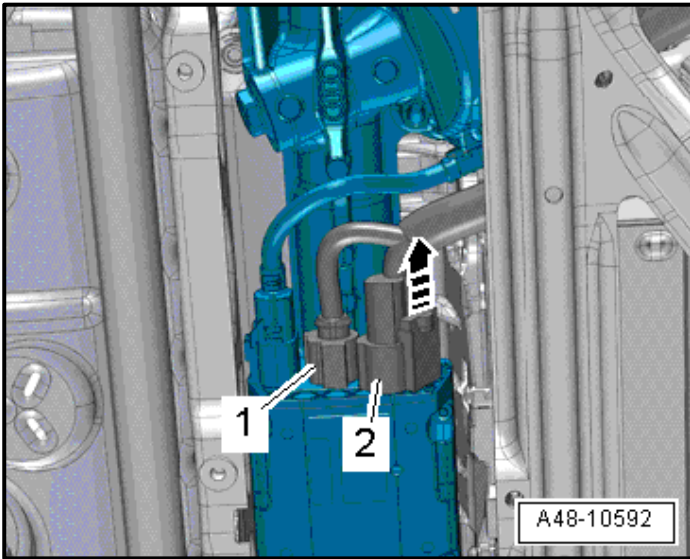

- Reconnect the connectors <1 and 2> to the Power Steering Control Module -J500-, ensuring that the safety catch is properly seated.

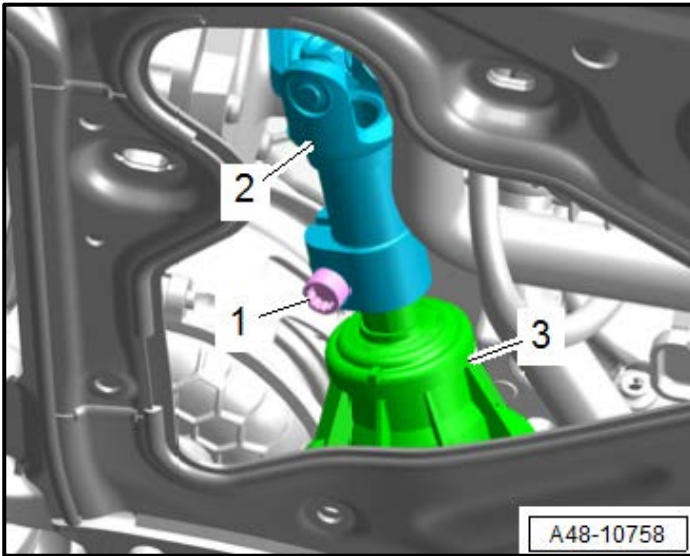

- Push the intermediate shaft universal joint <2> all the way on the steering rack <3>.
- Install the new bolt <1> several threads by hand.
- Check if the steering intermediate shaft is seated correctly by pulling.
- Tighten the new bolt to 20 Nm +90°

Part Number	Part Description	Qty.
N 105 184 05	Socket head bolt	1

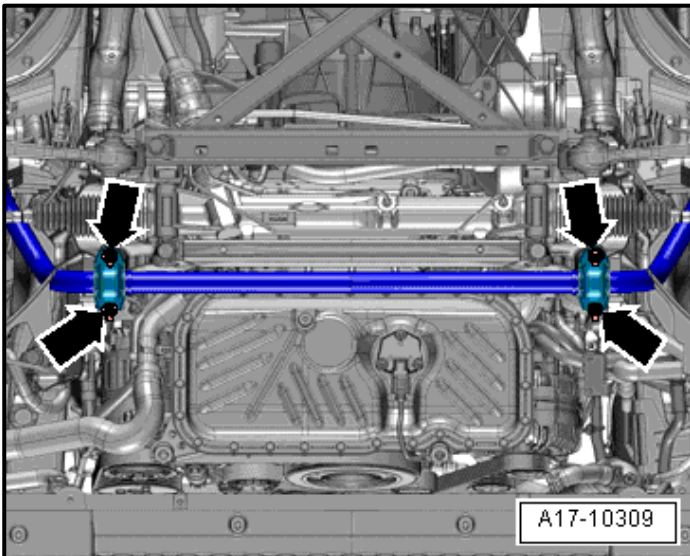

- Untie and reinstall the stabilizer bar and new nuts <arrows>.
- Tighten the nuts evenly alternating from side to side to 50 Nm.

Part Number	Part Description	Qty.
N 912 401 01	Nut	4

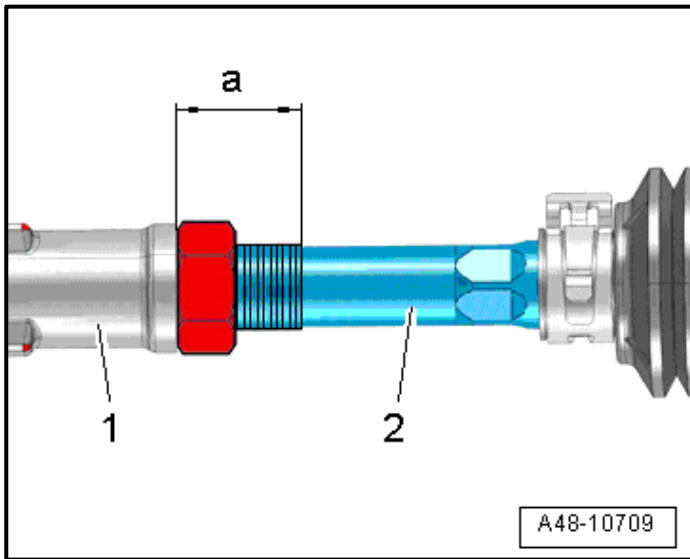

- Screw the tie rod end <1> on the tie rod <2> until dimension <a>, which was measured during removal, is reached.

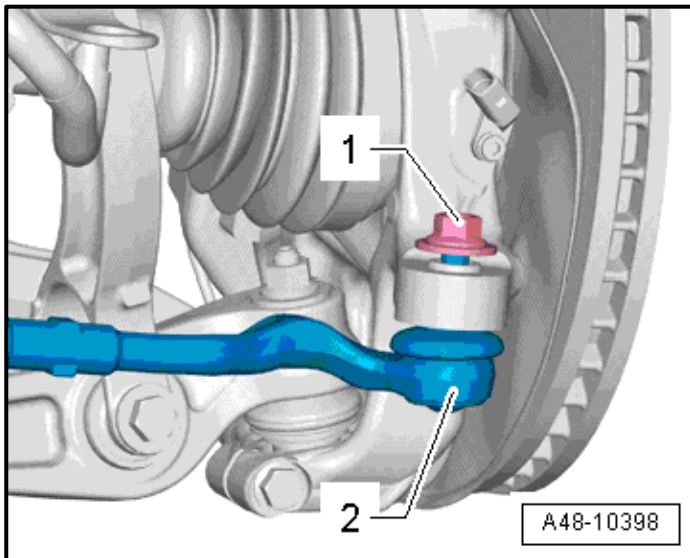

- Insert the tie rod end all the way into the wheel bearing housing.
- Counter-hold at the joint pin with a 6 mm hex socket wrench if necessary to tighten the new nut <1> to 140 Nm.

Part Number	Part Description	Qty.
WHT 006 151	Nut	2

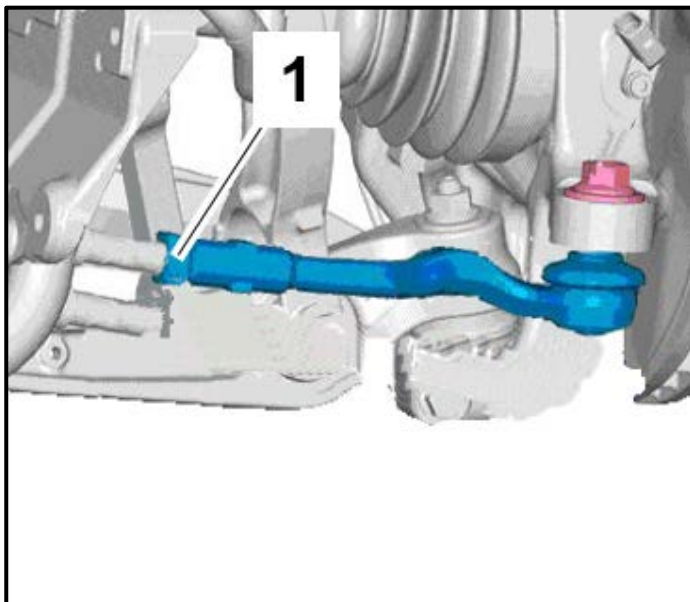

- Tighten the nut <1> to 80 Nm.

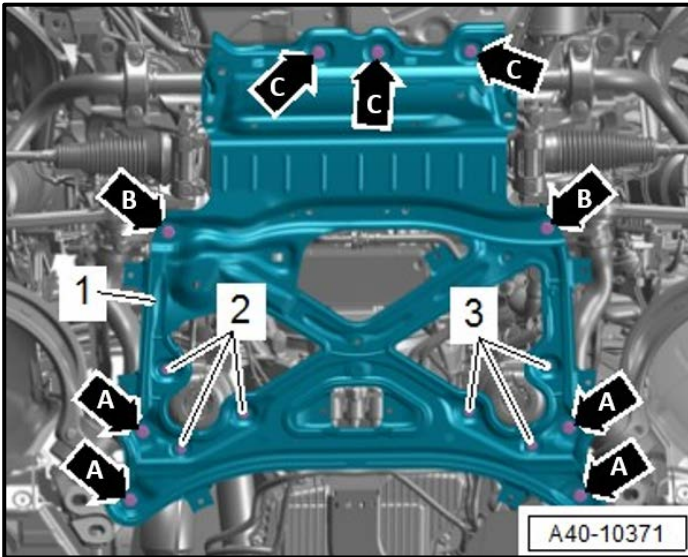

Equipment Versions with Side Transmission Mount:

- Reinstall bolts <2 and 3> and tighten to 20 Nm.

Equipment Versions without Sway Stabilization:

- Install new rear bolts <A> and tighten to 90 Nm +135°.
- Install new middle bolts and tighten to 90 Nm +90°.

Ref.	Part Number	Part Description	Qty.
A	N 911 511 01	Hexagon bolt	4
B	WHT 005 372	Socket head bolt	2

- Reinstall the front bolts <C> and tighten to 20 Nm.

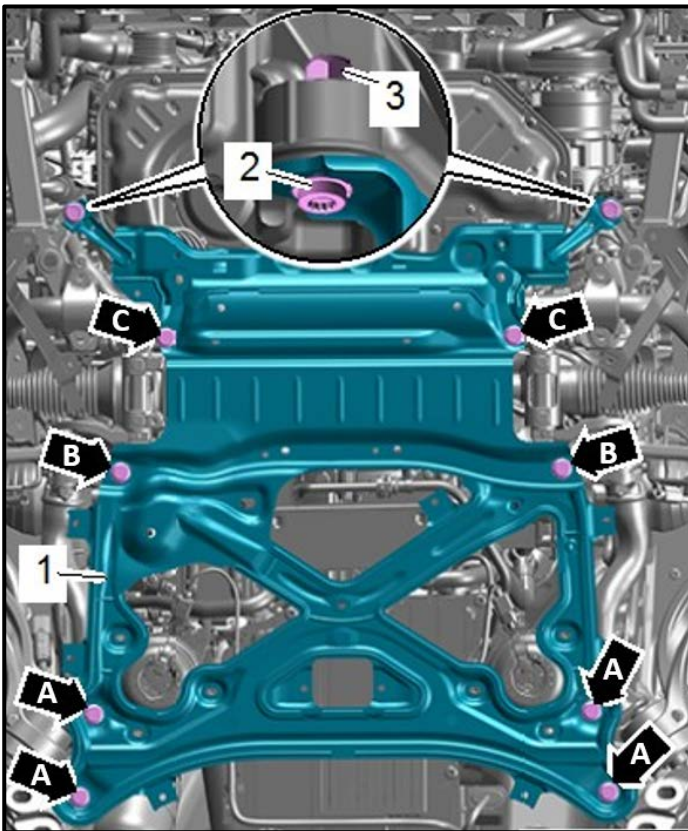

Equipment versions with Sway Stabilization:

- Install new rear bolts <A> and tighten to 90 Nm +135°.
- Install new middle bolts and tighten to 90 Nm +90°.

Ref.	Part Number	Part Description	Qty.
A	N 911 511 01	Hexagon bolt	4
B	WHT 005 372	Socket head bolt	2

- Reinstall the front bolts <C> and tighten to 20 Nm.
- Reinstall the corner bolts and nuts <2 and 3> and tighten to 20 Nm.

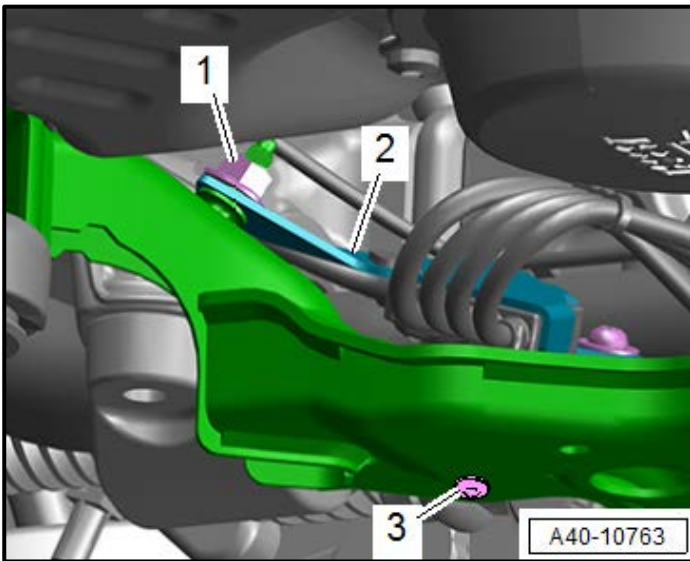

- Reinstall the bracket with the wires <2> into position.
- Reinstall the nut <1> and tighten to 9 Nm.
- Reinstall the bolt <3> and tighten to 9 Nm.

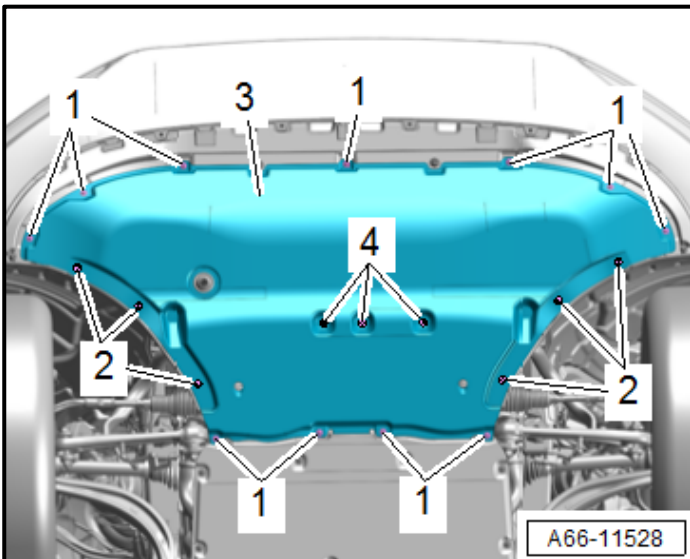

- Reinstall the front noise insulation <3>.
- Reinstall the front noise insulation bolts <4> and tighten to 6 Nm.
- Reinstall the front noise insulation bolts <1 and 2> and tighten to 2.5 Nm.
- Reinstall the front wheels.

- After installing a new steering rack with Power Steering Control Module -J500-, activate the control module.
 - Connect the Vehicle Diagnostic Tester.
 - Switch the ignition on.
 - Select and start the **Diagnostic** operating mode.
 - Select the **Test plan** tab.
 - Select the **Select individual test** button and select the following tree structure consecutively:
 - Chassis.
 - Steering.
 - 01 - OBD-capable systems.

- 44 - Power Steering Control Module J500.
 - 44 - Power Steering Control Module Functions.
 - 44 - Control Module, Replacing.
- Start the selected program and follow the instructions on the Vehicle Diagnostic Tester display.



- Remove the tape <arrows> from the steering wheel.
- Align the vehicle.
- **Proceed to Section C**

Section C – Campaign Completion Stamp

I certify that this campaign
has been performed in strict
accordance with the applicable
Audi repair procedure.

SAGA Code: _____
Technician: _____
Date: _____

Item#: AUD4927ENG

-OR-

Je certifie que cette
campagne de rappel a été
exécutée suivant les strictes
directives de réparation
d'Audi

Code de SAGA: _____
Technicien: _____
Date: _____

Item # AUD4927FRE

- Once the campaign has been completed, the technician should stamp the repair order.
- Stamps are available for ordering through the Compliance Label Ordering Portal.
- **Proceed to Section D**

ALL WORK IS COMPLETE

Section D - Parts Return

Parts Return/Disposal

Properly store (retain), destroy or dispose of removed parts in accordance with all state/province and local requirements, unless otherwise indicated and/or requested through the Warranty Parts Portal (WPP).