



Safety Recall

Code: 20Y6

REVISION

Subject	Suction Pump
Release Date	December 21, 2016
Revision Summary	Certain work instruction steps have been modified to help technicians avoid consequential damage during this repair.
Affected Vehicles	U.S.A. & CANADA: 2015-2016 MY Volkswagen Golf, GTI & Golf SportWagen <i>Check Campaigns/Actions screen in Elsa on the day of repair to verify that a VIN qualifies for repair under this action. Elsa is the <u>only</u> valid campaign inquiry & verification source.</i> <ul style="list-style-type: none">✓ Campaign status must show "open."✓ If Elsa shows other open action(s), inform your customer so that the work can also be completed at the same time the vehicle is in the workshop for this campaign.
Problem Description	The suction pump inside the fuel tank designed to purge fuel from the evaporative emissions (EVAP) system may have been damaged during assembly. This could cause fuel to flow directly into the EVAP system which could, over time, accumulate and cause a leak through the charcoal canister filter element. Leaking fuel, in the presence of an ignition source, may result in a fire.
Corrective Action	Replace the suction pump inside the fuel tank.
Precautions	If a fuel smell is detected in the vehicle, customers should immediately contact an authorized Volkswagen dealer to have the vehicle inspected. Additionally, customers may experience refueling issues (early stopping of the fuel nozzle and fuel spillback) when fuel accumulates in the EVAP system. If this happens, customers should immediately contact an authorized Volkswagen dealer to have the vehicle inspected.
Parts Information	Parts will be allocated prior to owner notification. <ul style="list-style-type: none">• Targeted allocation will be used for 5Q0201029 (suction pump).• Upper order limits will be used for 1J0919133B (seal). If your dealership is at the weekly Upper Order Limit, submit requests for additional parts via email to vwoupperorderlimits@vw.com.
Code Visibility	On or about October 13, 2016, affected vehicles were listed on the Inventory Vehicle Open Campaign Action report under My Dealership Reports (found on www.vw.com & OMD Web). A list was not posted for dealers who did not have any affected vehicles. On or about October 13, 2016, this campaign code showed open on affected vehicles in Elsa. On or about October 13, 2016, affected vehicles were identified with this campaign code in the VIN Lookup tool at www.vw.com and on the NHTSA VIN lookup tool at www.safercar.gov .
Owner Notification	Owner notification will take place in October. Owner letter examples are included in this bulletin for your reference.
Additional Information	Please alert everyone in your dealership about this action, including Sales, Service, Parts and Accounting personnel. Contact Warranty if you have any questions.

IMPORTANT REMINDER ON VEHICLES AFFECTED BY SAFETY & COMPLIANCE RECALLS

New Vehicles in Dealer Inventory: It is a violation of Federal law for a dealer to deliver a new motor vehicle or any new or used item of motor vehicle equipment (including a tire) covered by this notification under a sale or lease until the defect or noncompliance is remedied. By law, dealers must correct, prior to delivery for sale or lease, any vehicle that fails to comply with an applicable Federal Motor Vehicle Safety Standard or that contains a defect relating to motor vehicle safety.

Pre-Owned Vehicles in Dealer Inventory: Dealers should not deliver any pre-owned vehicles in their inventory which are involved in a safety or compliance recall until the defect has been remedied.

Dealers must ensure that every affected inventory vehicle has this campaign completed before delivery to consumers.

Fill out and affix Campaign Completion Label (CAMP 010 000) after work is complete.

Labels can be ordered at no cost via the Compliance Label Ordering portal at www.vwclub.com.

Claim Entry Instructions

After campaign has been completed, enter claim as soon as possible to help prevent work from being duplicated elsewhere. Attach the Elsa screen print showing action open on the day of repair to the repair order.

If customer refused campaign work:

- ✓ U.S. dealers: Submit request via WISE under the *Campaigns/Update/Recall Closure* option.
- ✓ Canada dealers: Fax repair order to Warranty at (905) 428-4811.

Service Number	20Y6									
Damage Code	0099									
Parts Vendor Code	WWO									
Claim Type	Sold vehicle: 7 10 Unsold vehicle: 7 90									
Causal Indicator	Mark suction pump as causal part*									
Vehicle Wash/Loaner	Do not claim wash/loaner under this action									
Criteria I.D.	01									
	Replace Suction Pump. Labor operation: 2066 23 99 110 T.U.									
	<table border="1"><thead><tr><th>Quantity</th><th>Part Number</th><th>Description</th></tr></thead><tbody><tr><td>1</td><td>5Q0201029</td><td>Suction Pump*</td></tr><tr><td>1</td><td>1J0919133B</td><td>Seal</td></tr></tbody></table>	Quantity	Part Number	Description	1	5Q0201029	Suction Pump*	1	1J0919133B	Seal
Quantity	Part Number	Description								
1	5Q0201029	Suction Pump*								
1	1J0919133B	Seal								

Customer Letter Example (USA) - INTERIM

<MONTH YEAR>

<CUSTOMER NAME>

<CUSTOMER ADDRESS>

<CUSTOMER CITY STATE ZIPCODE>

This notice applies to your vehicle: <VIN>

NHTSA: 16V647

IMPORTANT!

Information about Safety Recall 20Y6 – Suction Pump

Your vehicle is affected by the safety recall described in this letter; however, due to limited parts supply, your dealer may not be able to perform the recall work for you at this time. In the interim, if you have any concerns about driving your vehicle, or if you smell fuel in the vehicle, make an appointment with your authorized Volkswagen dealer to have the vehicle inspected/repaired without delay.

This notice is sent to you in accordance with the National Traffic and Motor Vehicle Safety Act. Volkswagen has decided that a defect, which relates to motor vehicle safety, exists in certain 2015-2016 model year Volkswagen Golf, GTI & Golf SportWagen vehicles. Our records show you are the owner of a vehicle affected by this recall.

Recall Description: On certain vehicles, the suction pump inside the fuel tank designed to purge fuel from the evaporative emissions (EVAP) system may have been damaged during assembly. This could cause fuel to flow directly into the EVAP system which could, over time, accumulate and cause a leak through the charcoal canister filter element. Leaking fuel, in the presence of an ignition source, could lead to a fire causing injury and/or damage to property.

Precautions You Should Take: If you smell fuel in the vehicle, make an appointment with your authorized Volkswagen dealer to have the vehicle inspected without delay.

Additionally, you may experience refueling issues (early stopping of the fuel nozzle and fuel spillback) when fuel accumulates in the EVAP system. If this happens, immediately contact the nearest authorized Volkswagen dealer to have the vehicle inspected.

To check your vehicle's eligibility for repair under this or any other recall/service campaign, please click on the *Look Up Recalls* link at www.vw.com and enter your Vehicle Identification Number (VIN) into the Recall/Service Campaign Lookup tool.

If you should have any questions about this communication, please don't hesitate to contact Customer CARE, Monday through Friday from 8AM to 10PM EST and Saturday from 9AM to 5PM EST by phone at 800-893-5298. You are also welcome to e-mail or chat through the "Contact Us" page <http://www.vw.com/contact/>.

If you still cannot obtain satisfaction, you may file a complaint with: The Administrator, National Highway Traffic Safety Administration, 1200 New Jersey Avenue, SE., Washington, DC 20590; or call the toll-free Vehicle Safety Hotline at 1-888-327-4236 (TTY: 1-800-424-9153); or go to <http://www.safercar.gov>.

We apologize for any inconvenience this matter may cause; however we are taking this action to help ensure your safety and continued satisfaction with your vehicle.

Sincerely,

Volkswagen Customer Protection

Customer Letter Example (USA) - LAUNCH

This notice applies to your vehicle: <VIN>

NHTSA: <INSERT NUMBER>

**Subject: Safety Recall 20Y5 – Suction Pump
Certain 2015-2016 Model Year Volkswagen Golf, GTI & Golf SportWagen Vehicles**

Dear Volkswagen Owner,

This notice is sent to you in accordance with the National Traffic and Motor Vehicle Safety Act. Volkswagen has decided that a defect, which relates to motor vehicle safety, exists in certain 2015-2016 model year Volkswagen Golf, GTI & Golf SportWagen vehicles. Our records show that you are the owner of a vehicle affected by this action.

What is the issue?	The suction pump inside the fuel tank designed to purge fuel from the evaporative emissions (EVAP) system may have been damaged during assembly. This could cause fuel to flow directly into the EVAP system which could, over time, accumulate and cause a leak through the charcoal canister filter element. Leaking fuel, in the presence of an ignition source, may result in a fire.
What will we do?	To help correct this defect, your authorized Volkswagen dealer will replace the suction pump inside the fuel tank. This work will take less than two hours to complete and will be performed for you free of charge.
What should you do?	Please contact your authorized Volkswagen dealer without delay to schedule this recall repair. For your convenience, you can also visit www.vw.com and click on the "Owners" link to locate a dealer near you and schedule this service online.
Precautions you should take	If you smell fuel in the vehicle, immediately contact the nearest authorized Volkswagen dealer to have the vehicle inspected. Additionally, you may experience refueling issues (early stopping of the fuel nozzle and fuel spillback) when fuel accumulates in the EVAP system. If this happens, immediately contact the nearest authorized Volkswagen dealer to have the vehicle inspected.
Lease vehicles and address changes	If you are the lessor and registered owner of the vehicle identified in this action, the law requires you to forward this letter immediately via first-class mail to the lessee within ten (10) days of receipt. If you have changed your address or sold the vehicle, please fill out the enclosed prepaid Owner Reply card and mail it to us so we can update our records.
Reimbursement of Expenses	If you have previously paid for repairs relating to the condition described in this letter, please refer to the enclosed form that explains how to request reimbursement.
Can we assist you further?	If your authorized Volkswagen dealer fails or is unable to complete this work free of charge within a reasonable time, or if you should have any questions about this communication, please reach out to us using your preferred method of communication at www.vw.com/contact or by calling 1 800-893-5298. Our phone team is available Monday through Friday from 8AM to 10PM EST and Saturday from 9AM to 5PM EST.
Checking your vehicle for open Recalls and Service Campaigns	To check your vehicle's eligibility for repair under this or any other recall/service campaign, please click on the Look Up Recalls link at www.vw.com and enter your Vehicle Identification Number (VIN) into the Recall/Service Campaign Lookup tool.

If you still cannot obtain satisfaction, you may file a complaint with: The Administrator, National Highway Traffic Safety Administration, 1200 New Jersey Avenue, SE., Washington, DC 20590; or call the toll-free Vehicle Safety Hotline at 1-888-327-4236 (TTY: 1-800-424-9153); or go to <http://www.safercar.gov>.

We apologize for any inconvenience this matter may cause; however we are taking this action to help ensure your safety and continued satisfaction with your vehicle. Thank you for driving a Volkswagen!

Sincerely,

Volkswagen Customer Protection

Customer Letter Example (CANADA) - INTERIM

<MONTH YEAR>

<CUSTOMER NAME>

<CUSTOMER ADDRESS>

<CUSTOMER CITY STATE ZIPCODE>

This notice applies to your vehicle: <VIN>

IMPORTANT!

Information about Safety Recall 20Y6 – Suction Pump

Your vehicle is affected by the safety recall described in this letter; however, due to limited parts supply, your dealer may not be able to perform the recall work for you at this time. In the interim, if you have any concerns about driving your vehicle, or if you smell fuel in the vehicle, make an appointment with your authorized Volkswagen dealer to have the vehicle inspected/repaired without delay.

This notice is sent to you in accordance with the requirements of the Motor Vehicle Safety Act. Volkswagen has decided that a defect, which relates to motor vehicle safety, exists in certain 2015-2016 model year Volkswagen Golf, GTI & Golf SportWagen vehicles. Our records show you are the owner of a vehicle affected by this recall.

Recall Description: On certain vehicles, the suction pump inside the fuel tank designed to purge fuel from the evaporative emissions (EVAP) system may have been damaged during assembly. This could cause fuel to flow directly into the EVAP system which could, over time, accumulate and cause a leak through the charcoal canister filter element. Leaking fuel, in the presence of an ignition source, could lead to a fire causing injury and/or damage to property.

Precautions You Should Take: If you smell fuel in the vehicle, make an appointment with your authorized Volkswagen dealer to have the vehicle inspected without delay.

Additionally, you may experience refueling issues (early stopping of the fuel nozzle and fuel spillback) when fuel accumulates in the EVAP system. If this happens, immediately contact the nearest authorized Volkswagen dealer to have the vehicle inspected.

If you should have any questions about this communication, please contact Customer Relations, Monday through Friday from 8AM to 8PM EST by phone at 1-800-822-8987 or via our "Contact Us" page at www.vw.ca.

We apologize for any inconvenience this matter may cause; however we are taking this action to help ensure your safety and continued satisfaction with your vehicle.

Sincerely,

Volkswagen Customer Protection

Customer Letter Example (CANADA) - LAUNCH

<MONTH YEAR>

<CUSTOMER NAME>

<CUSTOMER ADDRESS>

<CUSTOMER CITY STATE ZIPCODE>

This notice applies to your vehicle: <VIN>

**Subject: Safety Recall 20Y5 – Suction Pump
Certain 2015-2016 Model Year Volkswagen Golf, GTI & Golf SportWagen Vehicles**

Dear Volkswagen Owner,

This notice is sent to you in accordance with the requirements of the Motor Vehicle Safety Act. Volkswagen has decided that a defect, which relates to motor vehicle safety, exists in certain 2015-2016 model year Volkswagen Golf, GTI & Golf SportWagen vehicles. Our records show that you are the owner of a vehicle affected by this action.

- What is the issue?** The suction pump inside the fuel tank designed to purge fuel from the evaporative emissions (EVAP) system may have been damaged during assembly. This could cause fuel to flow directly into the EVAP system which could, over time, accumulate and cause a leak through the charcoal canister filter element. Leaking fuel, in the presence of an ignition source, may result in a fire.
- What will we do?** To help correct this defect, your authorized Volkswagen dealer will replace the suction pump inside the fuel tank. This work will take less than two hours to complete and will be performed for you free of charge.
- What should you do?** Please contact your authorized Volkswagen dealer without delay to schedule this recall repair.
- Precautions you should take** If you smell fuel in the vehicle, immediately contact the nearest authorized Volkswagen dealer to have the vehicle inspected.

Additionally, you may experience refueling issues (early stopping of the fuel nozzle and fuel spillback) when fuel accumulates in the EVAP system. If this happens, immediately contact the nearest authorized Volkswagen dealer to have the vehicle inspected.
- Lease vehicles and address changes** If you are the lessor and registered owner of the vehicle identified in this action, the law requires you to forward this letter immediately via first-class mail to the lessee within ten (10) days of receipt. If you have changed your address or sold the vehicle, please fill out the enclosed prepaid Owner Reply card and mail it to us so we can update our records.
- Reimbursement of Expenses** If you have previously paid for repairs relating to the condition described in this letter, please refer to the enclosed form that explains how to request reimbursement.
- Can we assist you further?** If your authorized Volkswagen dealer fails or is unable to complete this work free of charge within a reasonable time, please contact Customer Relations, Monday through Friday from 8AM to 8PM EST by phone at 1-800-822-8987 or via our "Contact Us" page at www.vw.ca.

We apologize for any inconvenience this matter may cause; however we are taking this action to help ensure your safety and continued satisfaction with your vehicle. Thank you for driving a Volkswagen!

Sincerely,

Volkswagen Customer Protection

NOTE

Damages resulting from improper repair or failure to follow these work instructions are the dealer's responsibility and are not eligible for reimbursement under this action.

Required Parts

<u>Quantity</u>	<u>Part Number</u>	<u>Part Description</u>
1	5Q0-201-029	Suction Pump
1	1J0-919-133-B	Seal

Required Tools

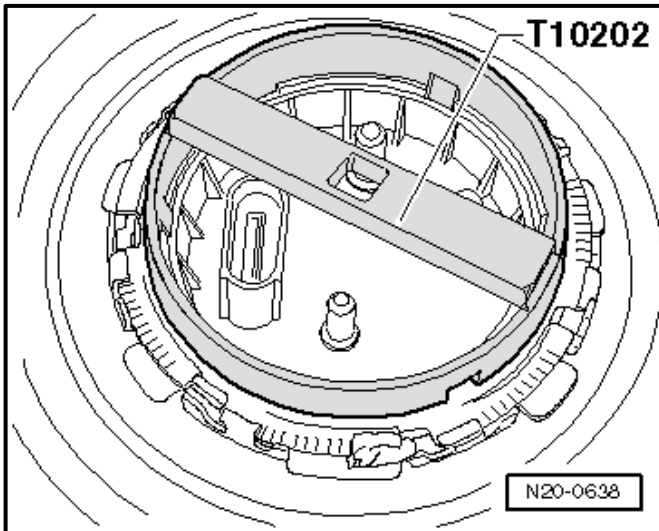

- Wrench - Fuel Sending Unit -T10202-

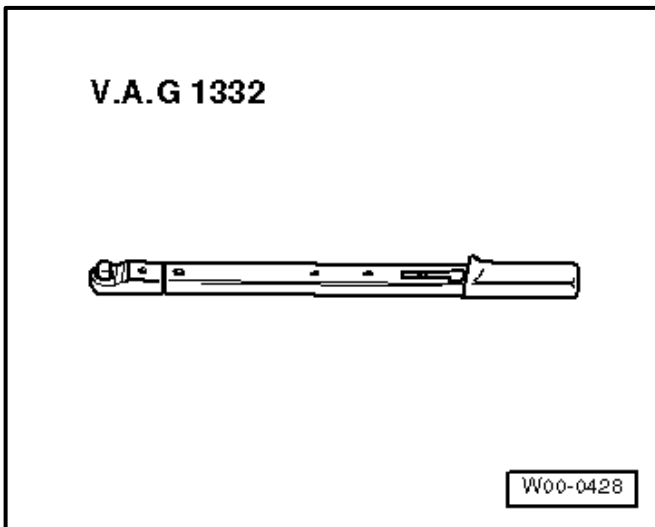

- Torque Wrench 1332 40-200Nm -VAG1332- (or equivalent)

3409

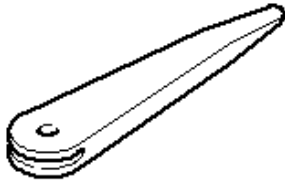

VW00-0016

- Trim Removal Wedge -3409-



- VAS6150D - Diagnostic Tester (or equivalent)
- VAS6154 - Vehicle Communication Interface (or equivalent)



- GRX3000VAS – Battery Tester/Charger (or equivalent)

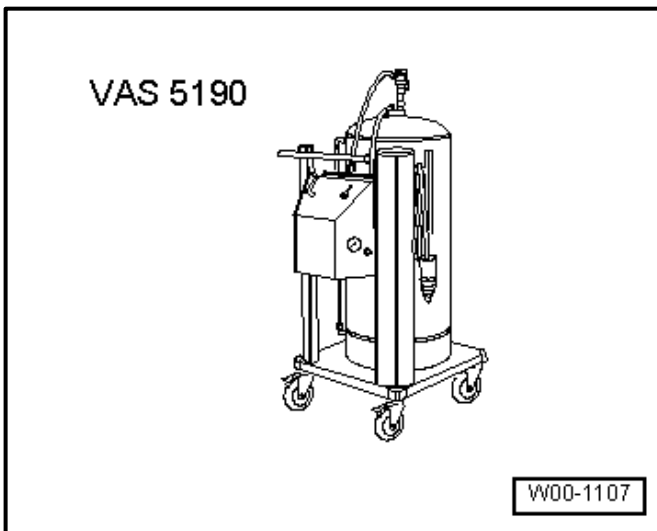



- Fuel Extractor VAS5190A -VAS5190-

Repair Instruction

Section A - Check for Previous Repair

TIP

If Campaign Completion label is present, no further work is required.

Applicable criteria ID(s)	Campaign/Action Status
01 	Open 

EXAMPLE

- Enter the VIN in Elsa and proceed to the “Campaign/Action” screen.

TIP

On the date of repair, print this screen and keep a copy with the repair order.

- Confirm the Campaign/Action is open <arrow 1>. If the status is closed, no further work is required.
- Note the Applicable Criteria ID <arrow 2> for use in determining the correct work to be done and corresponding parts associated.

Proceed to Section B

Section B – Repair Procedure

NOTE

- Due to variations in vehicle equipment and options, the steps/illustrations in this work procedure may not identically match all affected vehicles.
- This procedure must be read in its entirety before performing the repair.

NOTE

Follow these “rules” when working on the fuel supply system:

- Thoroughly clean the connecting points and the surrounding area before loosening.
- Place the removed parts on a clean surface and cover them. Only use lint-free cloths!
- Carefully cover or seal opened components if the repair will not be done immediately.
- Only install clean parts: remove replacement parts from the packaging immediately prior to installation. Do not use parts that have been stored loose (for example, in tool boxes etc.).
- When the system is open: do not work with compressed air.
- Do not move vehicle.
- Seal off any open lines and connections immediately with plugs, for example, take from -VAS6122-.
- Protect the disconnected connectors from dirt and moisture and only connect when they are dry.
- Before starting work, place the extracting hose on an exhaust extractor that is switched on near the fuel tank assembly opening to extract fuel vapors.

WARNING

Risk for repeat repair!

It is imperative that the battery is disconnected before draining the fuel. Failing to disconnect the battery can result in fuel level sending unit faults, or fuel gauge inaccuracies. Additional diagnostic time required to perform a capacitive discharge or remove fused power to the instrument cluster to clear these faults or inaccuracies are NOT covered under this campaign.

- Move the front seats all the way forward.
 - On vehicles equipped with power seats, be sure to move the front seats all the way forward before disconnecting the battery in the next step.

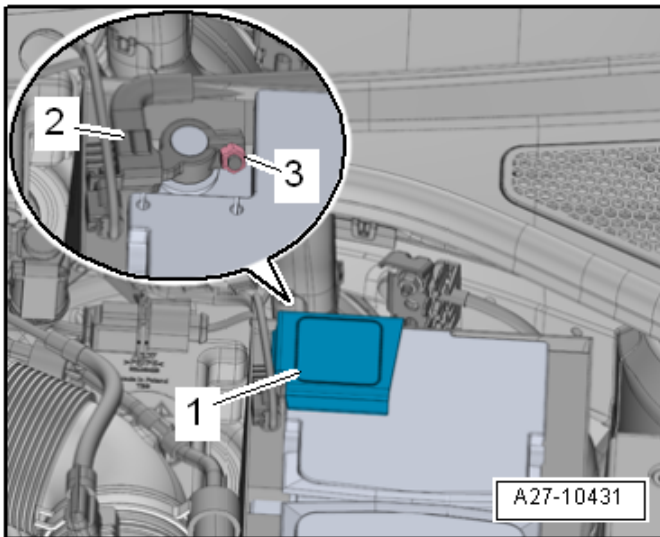

- Open the vehicle hood.
- Open the battery heat protection sleeve cover to access the cover <1> on the battery ground terminal <2>.
- Loosen the nut <3> several turns and remove the battery ground terminal <2> from the negative battery post and isolate the terminal.

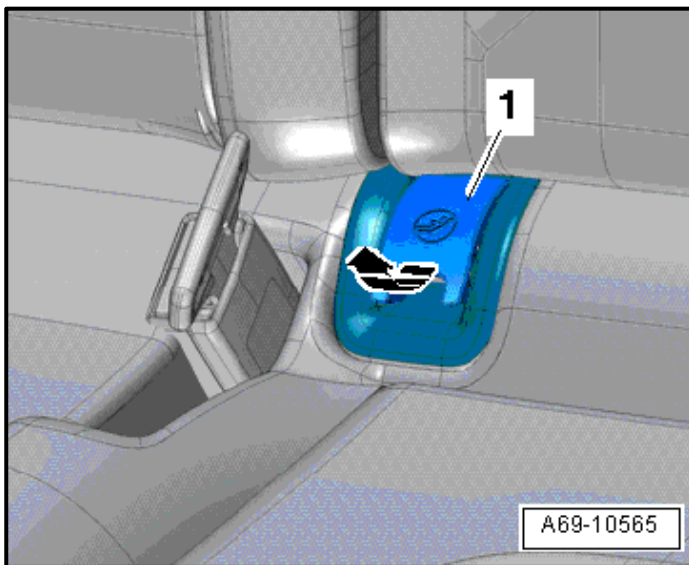

- Unclip and remove the covers <1> from the LATCH child seat anchors <arrow>.

CAUTION

Edges on the child seat anchor cover may be sharp.

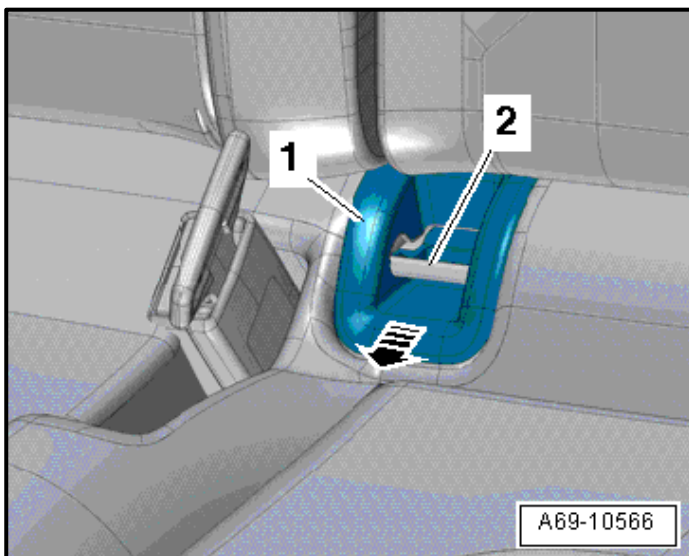

- Push the guides <1>, corresponding to cut-out, downward and disengage them from the LATCH child seat anchors <2>.

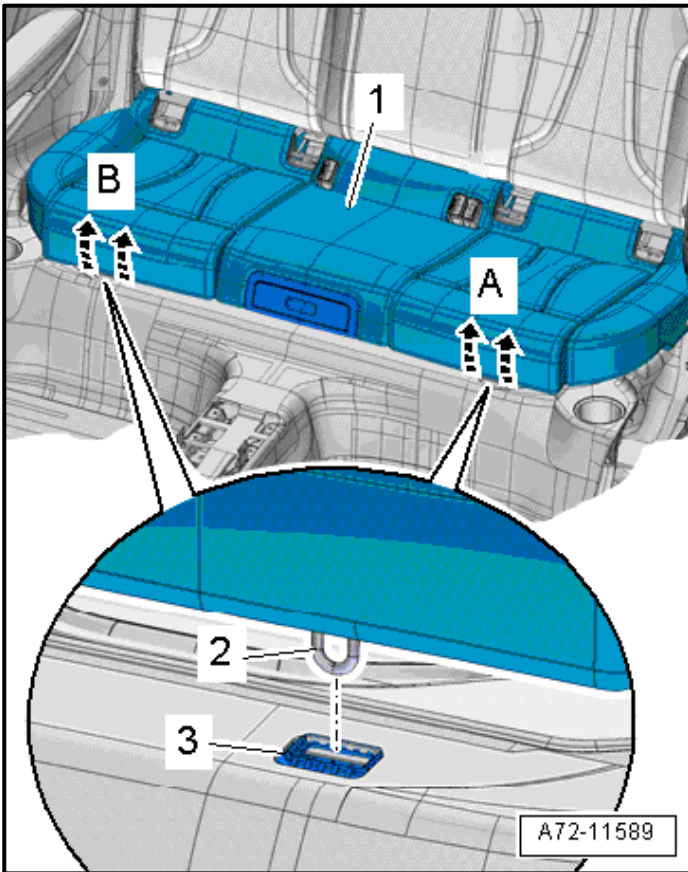

- With both hands, grasp the rear bench seat under the seat frame.
- Pull the rear bench seat <1> up forcefully with both hands <arrows A> so the wire hooks <2> on the rear bench seat release from the mounting grommet <3>.
- Repeat the procedure on the other side of the rear bench seat <arrows B>.

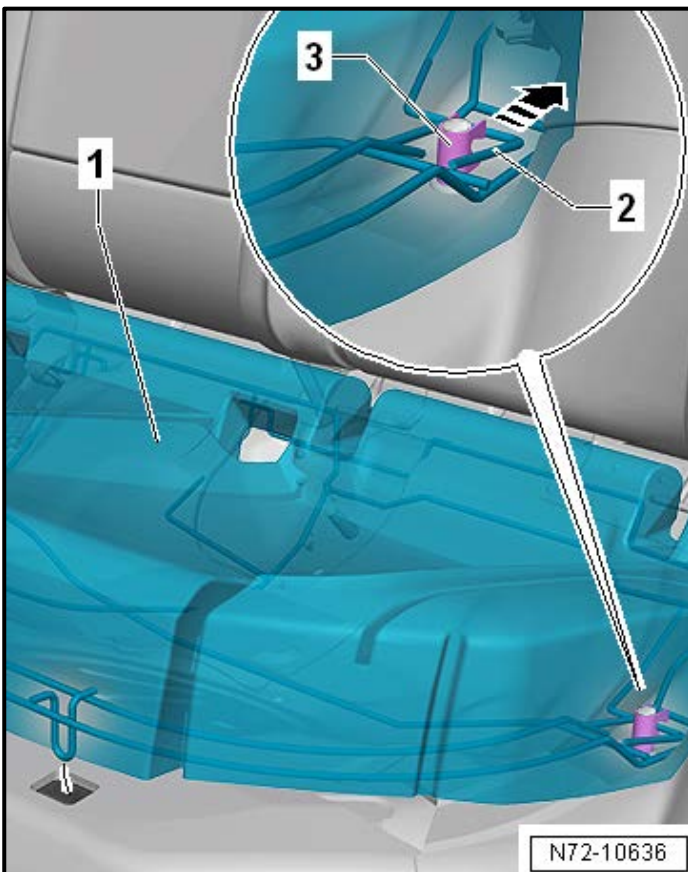

- Gently lift the rear bench seat <1> at front and slide the wire frame <2> out of the hook <3> toward the rear.
- Remove the rear bench seat from the vehicle.

NOTE

Place the seat bench in a clean location where it will not be damaged. Damage to the seat bench is not covered under this action.

⚠ WARNING

Risk for repeat repair!

It is imperative that the exact amount of fuel removed from the fuel tank is reinstalled into the fuel tank at the end of this operation. Failing to reinstall the same amount of fuel that was extracted can result in fuel level sending unit faults, or fuel gauge inaccuracies. Additional diagnostic time required to perform a capacitive discharge or remove fused power to the instrument cluster to clear these faults or inaccuracies are NOT covered under this campaign.

⚠ CAUTION

Danger due to escaping fuel.

- Drain the fuel tank.
 - If fuel tank is more than $\frac{3}{4}$ full, proceed to subsection 1.
 - If fuel tank is less than $\frac{3}{4}$ full, proceed to subsection 2.

Subsection 1 – Fuel Tank More Than $\frac{3}{4}$ Full

! NOTE

Use only the Fuel Extractor Unit -VAS5190A- when extracting E 85 - fuel!

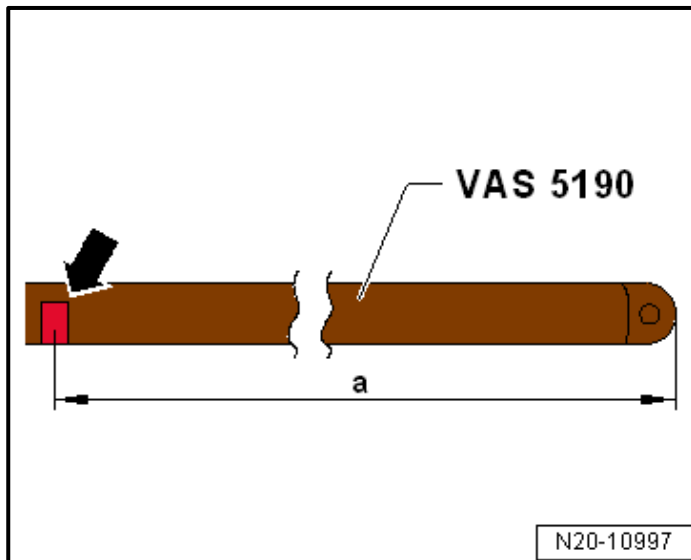

- Use insulating tape to mark the hose <arrow> at the distance <a> from the end of the suction hose on the -VAS5190-.

Rear Axle	Distance of <a>
Multi-link	945 mm
Torsion Beam Rear Suspension	1010 mm

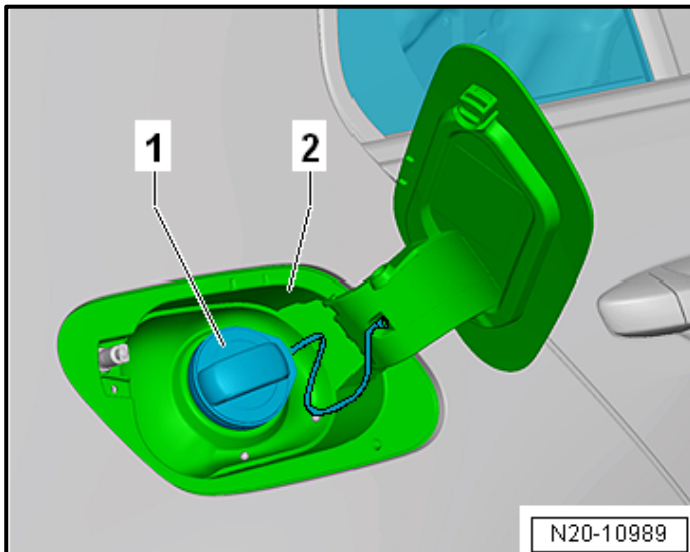

- Open the fuel filler door unit.
- Clean the area around the fuel filler neck <2>.
- Remove the cap <1> for the fuel filler neck.
- Attach the ground wire from the -VAS5190A- to a bare area on the body.

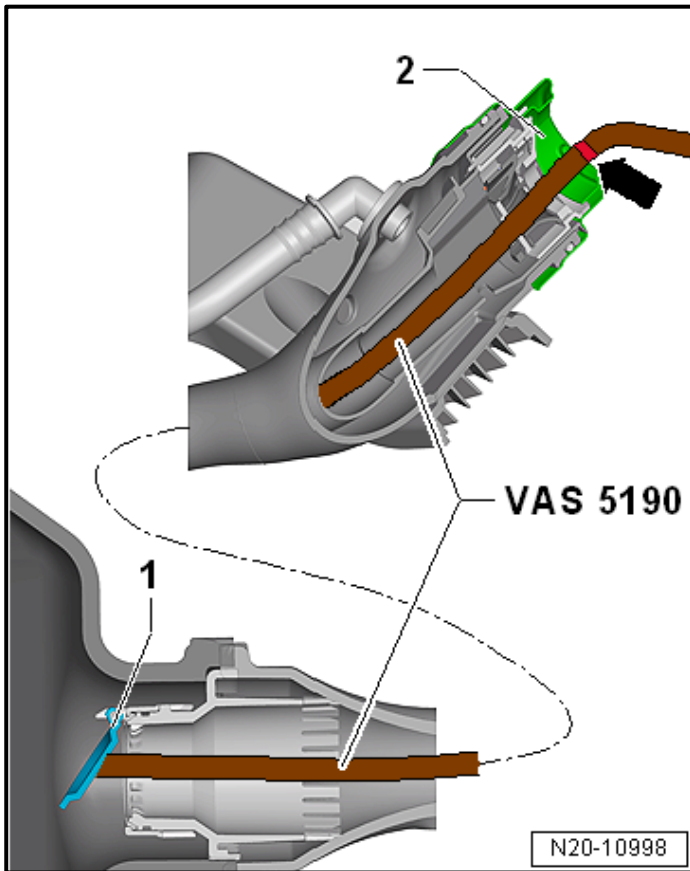

- Slide the suction hose from the -VAS5190A- into the fuel tank until the previously made mark -arrow- meets the filler neck <2>.
- Drain the fuel tank as much as possible through the filler neck.

NOTE

- A valve <1> is located in the fuel tank on the lower end of the filler neck. It must not be damaged by the suction hose. Only slide the hose in as far as the mark that was made earlier <arrow>.
- When no more fuel can be extracted, the fuel tank has been emptied enough so that the sensor flange can be opened safely.

- Carefully remove the suction hose.

NOTE

Do not use force to remove the suction hose if it gets stuck on the check valve. In this case, remove the fuel delivery unit and manually hold the check valve open. When doing this, make sure the arm does not come in contact with the fuel.

Proceed to Subsection 2.

Subsection 2 – Fuel Tank Less Than $\frac{3}{4}$ Full

WARNING

- The fuel system is under high pressure.
- Risk of injury from fuel spraying out.
- Reduce the pressure before continuing procedure.

Risk of a fire due to leaking fuel.

- When the battery is connected, the door contact switch activates the fuel pump when opening the driver door. Leaking fuel can ignite and start a fire.
- Before opening the fuel system, interrupt the power supply to the fuel pump.

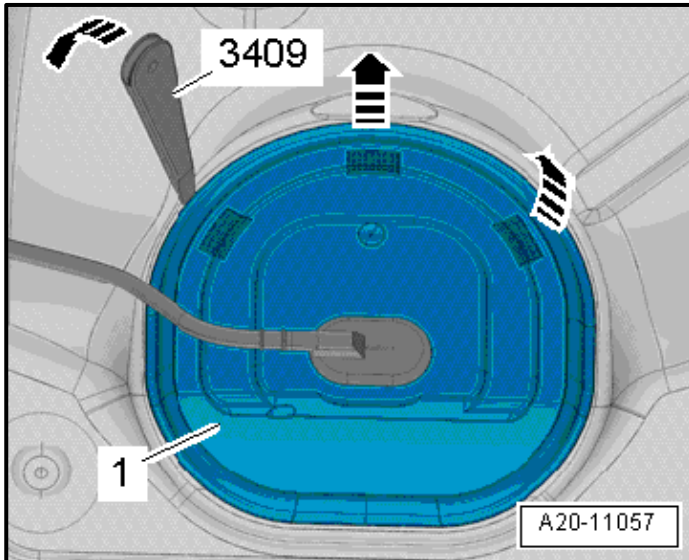

- In the rear seat, unclip the sealing flange cover <1> at the tabs <arrows> using the Trim Removal Wedge -3409-.

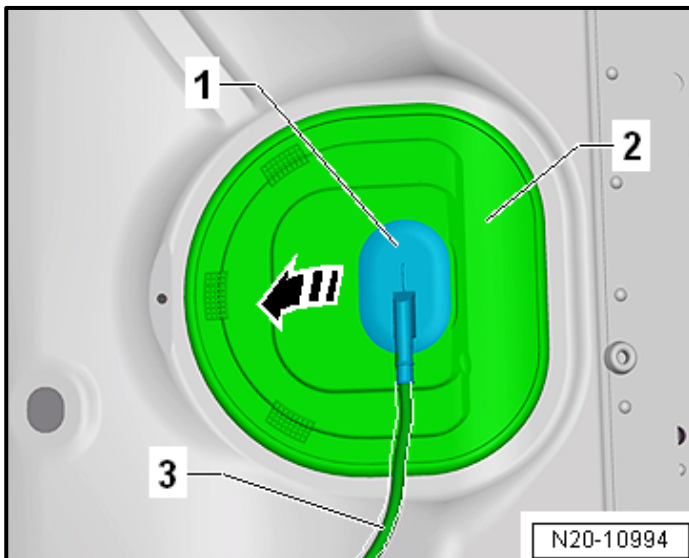

- Unclip the grommet <1> downward out of the cover <2>.

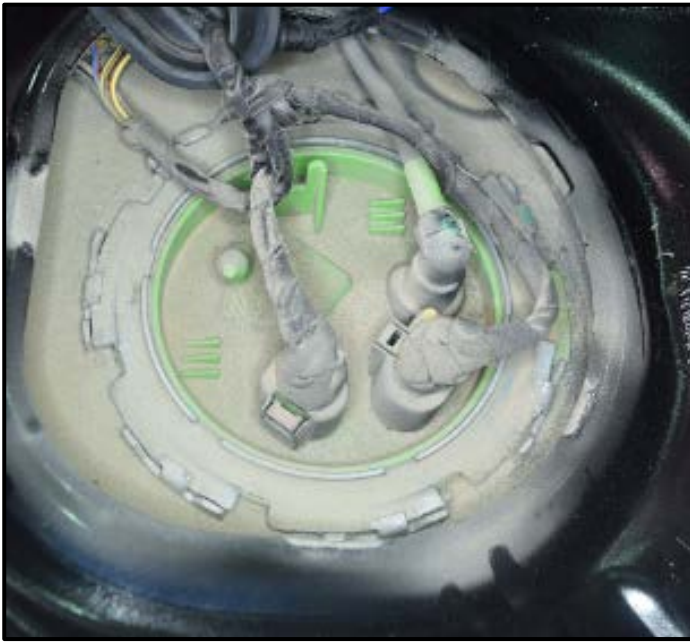

- Prior to disassembly, the fuel delivery unit **MUST** be clean. If excessive dirt or debris is present <as shown>, clean and dry the fuel delivery unit and surrounding areas as necessary.

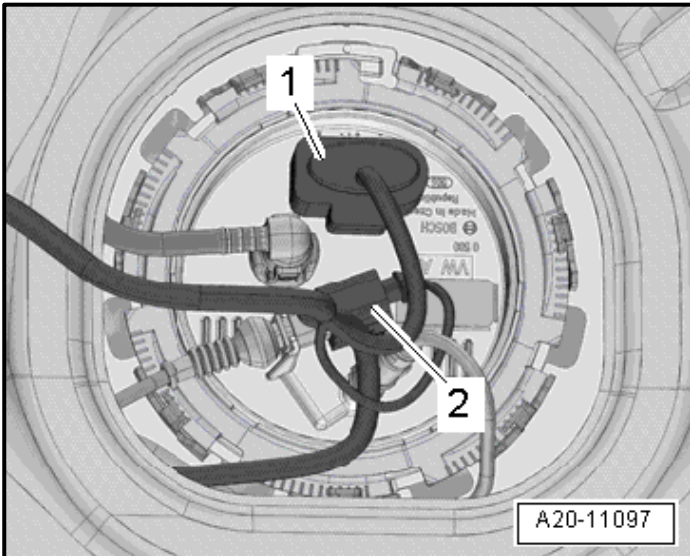

- Unlock and disconnect the connector <1> from the sealing flange.
- If equipped, disengage the connector <2> for the parking heater Metering Pump -V54- on the sealing flange and move it to the side.

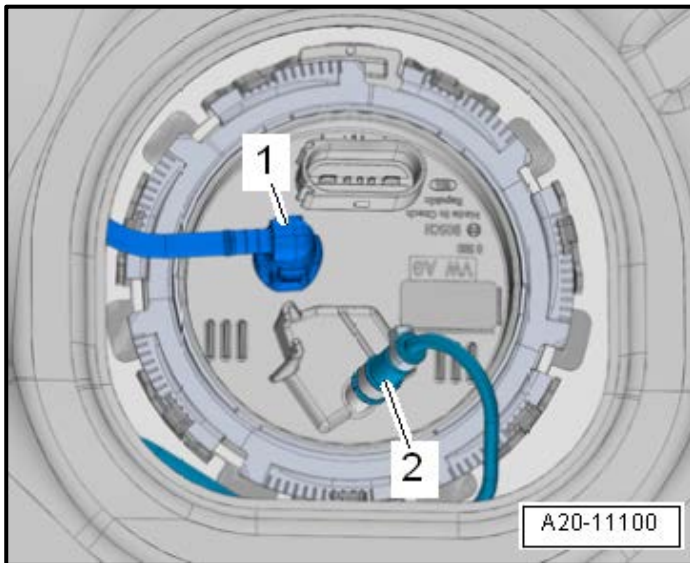

⚠ WARNING

Fuel lines are under pressure. Danger of personal injury to eyes and skin. Wear protective eyewear and protective clothing in order to avoid injury and contact with the skin. Wrap a cloth around the connection **before** loosening hose connections. Open the connection carefully and release the pressure.

- Remove the fuel line connector <1> from the locking flange by pushing down on the connector, squeezing the release tab between the finger and thumb, then lifting up.
- If equipped, remove the fuel line <2> to the Metering Pump -V54- for the parking heater on the sealing flange by loosening the lower hose clamp.

! NOTE

Risk for repeat repair!

- Do not use pliers or other tools on the fuel line connector(s) or damage to the connector may occur.
- Damage to the fuel line connector due to improper removal/installation may cause the connector to not fasten securely upon reinstallation, causing a leak. A damaged fuel line connector requires replacement of the fuel line.
- Consequential damage to the fuel line connector(s) due to improper removal/installation is not covered under this campaign.

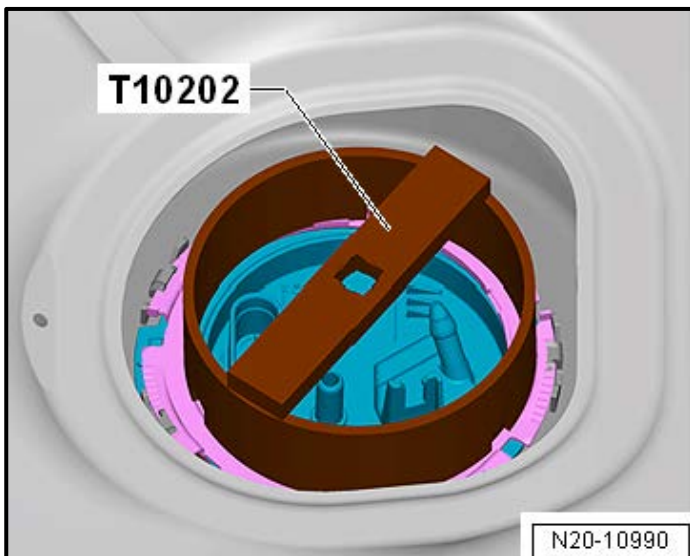

- Remove the locking ring using the Wrench - Fuel Sending Unit -T10202-.
- Carefully lift the fuel delivery unit flange.

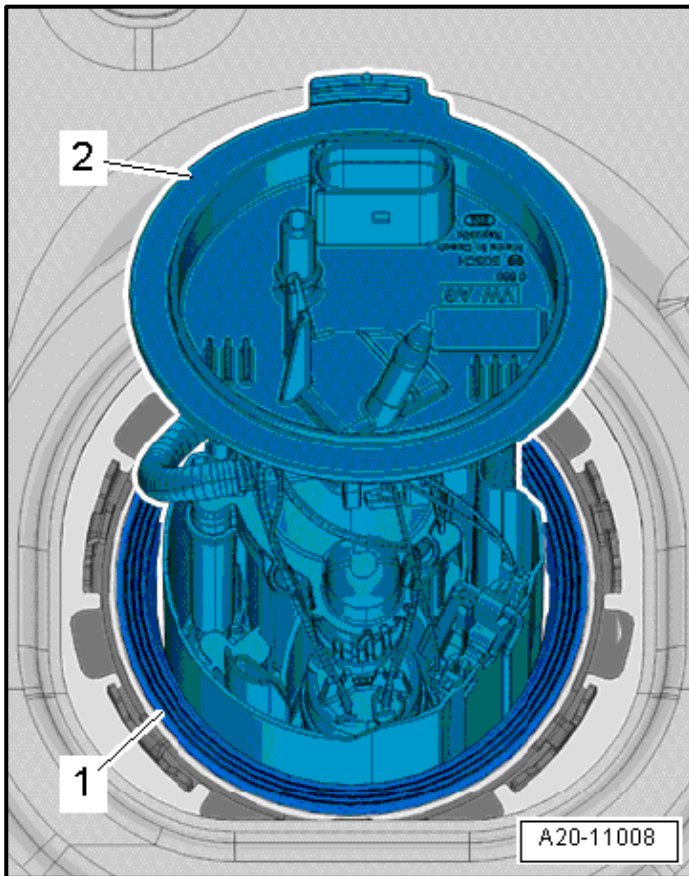

- Pull the sealing flange <2> out of the opening in the fuel tank slightly.
- Remove the seal <1> and slightly lift the fuel delivery unit flange again carefully.

NOTE

Use only the Fuel Extractor Unit -VAS5190A- when extracting E 85 - fuel!

- Attach the ground wire of the -VAS5190- to a bare area on the body.
- Insert the suction hose for the -VAS5190- as deep as possible into the fuel tank.
- Extract the fuel using the -VAS5190.
- Insert the extraction hose into the fuel delivery unit.
- Drain as much fuel as possible from the fuel delivery unit itself.
- Record the total amount of fuel extracted using the -VAS 5190- Fuel Extraction Unit on the repair order.

WARNING

Risk for repeat repair!

- It is imperative that the exact amount of fuel removed from the fuel tank is reinstalled into the fuel tank at the end of this operation.
- Failing to reinstall the same amount of fuel that was extracted can result in fuel level sending unit faults, or fuel gauge inaccuracies.
- Additional diagnostic time required to perform a capacitive discharge or remove fused power to the instrument cluster to clear these faults or inaccuracies are NOT covered under this campaign.

- Once the fuel has been properly evacuated, carefully pull the fuel delivery unit with the fuel level sensor out through the opening in the fuel tank, using caution not to bend the floater arm on the fuel level sensor when removing.

CAUTION

Risk for repeat repair!

During removal of the fuel delivery unit, it is very easy to damage the fuel level sensor. Use caution when removing the fuel delivery unit. Damage to the fuel level sensor is not covered under this action.

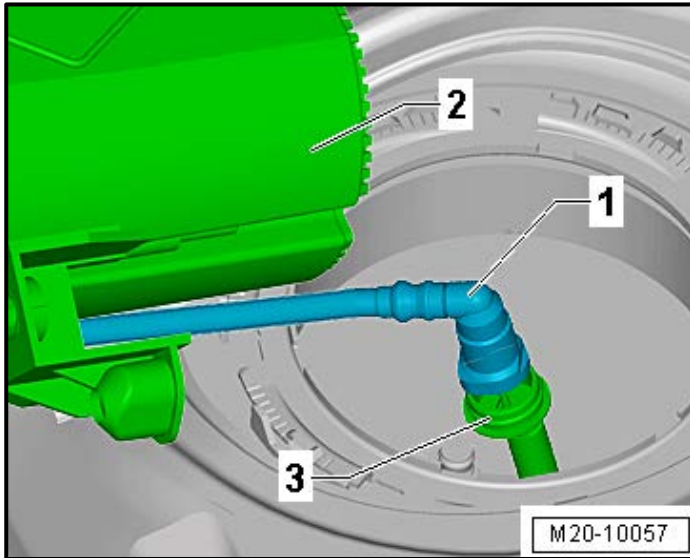

- Place a cloth underneath to catch the residual fuel, since the fuel delivery unit may still be partially filled.
- Carefully pull the fuel delivery unit <2> out of the fuel tank, release the fuel line <1> and disconnect it from the front suction line <3>.
- Lay a cloth inside the vehicle to absorb any residual fuel.

NOTE

- Follow all waste disposal regulations.
- Check the fuel tank for contamination.

NOTE

Risk for repeat repair!

- Do not use pliers or other tools on the fuel line connector <1> or damage to the connector may occur.
- Damage to the fuel line connector due to improper removal/installation may cause the connector to not fasten securely upon reinstallation, causing a leak. A damaged fuel line connector on the suction pump line requires replacement of the FUEL TANK.
- Consequential damage to the fuel tank due to connector damage from improper removal/installation is not covered under this campaign.

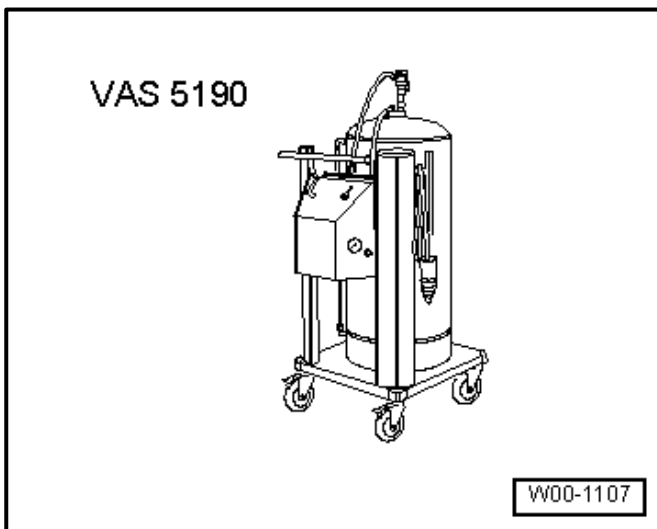

- After the fuel delivery unit is removed from the fuel tank opening and the suction pump line is disconnected, insert the suction hose from the -VAS 5910- Fuel Extraction Unit to remove as much additional fuel as necessary to perform the remaining operations safely and comfortably.
- Add any additional fuel removed from the fuel delivery unit and/or the bottom of the tank to the fuel volume previously recorded on the repair order.

WARNING

Danger due to fuel contacting skin

- To prevent injury or discomfort, wear proper protective gear when skin may come in contact with fuel. Proper fuel resistant gloves are advised.
- Take care when working on a vehicle that has been stored outdoors in extreme climate conditions. Fuel will not freeze when exposed to extreme cold, therefore the fuel in the tank may be well below 0°C.



Use cold weather protective gear or equipment as necessary, drain all of the fuel out, or warm the vehicle indoors if the vehicle has been stored in an extreme climate condition before performing the next steps.

NOTE

- Check the fuel tank for contamination and if any is noted use the VAS 5190 Fuel Extraction Unit to vacuum any debris from the tank. If necessary, use a lint free cloth to remove any debris once all fuel has been removed.

Replacing the suction jet pump:

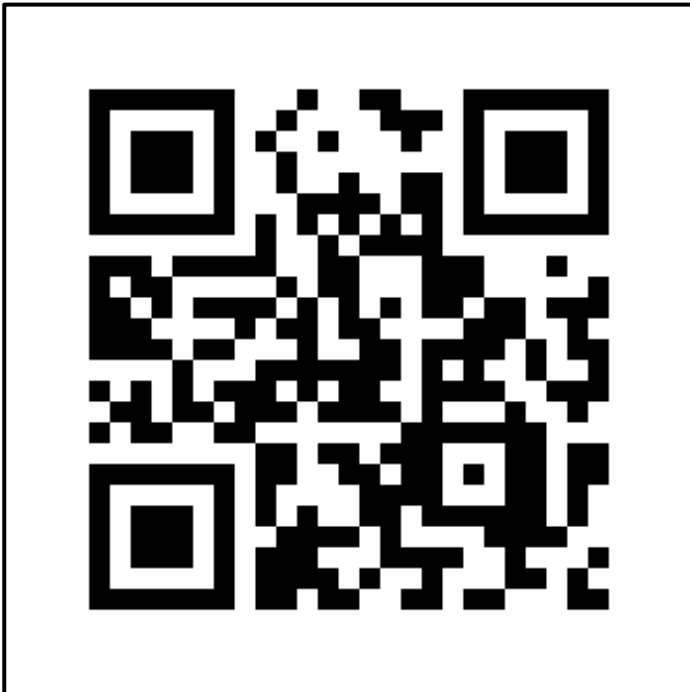

TIP

- To view a short video overview on removing and reinstalling the suction pump, scan the QR code to the left.
- The QR code is for viewing the video on smartphones and tablets. Alternatively, the video can also be accessed through computer internet browsers with the link below:

https://youtu.be/O1H7_8IRTVI

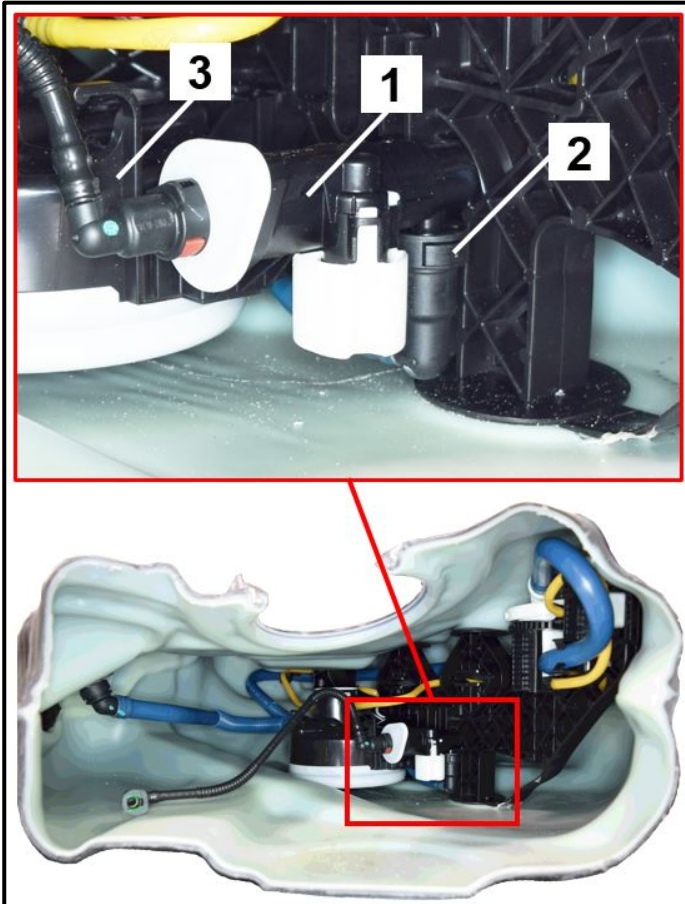

NOTE

- The fuel tank in the illustration below has been sectioned to provide a clear view of the suction valve.
- Under no circumstances should the fuel tank be altered or modified as shown below.

- Reach into the fuel tank and follow the black hose to find the suction pump <1>.
- Disconnect the rear suction line <2>:
 - Push the connector further onto the suction pump.
 - Press and hold the quick release connector latch in with the thumb.
 - Pull the connector off (downward).

NOTE

Risk for repeat repair!

- Do not use pliers or other tools on the fuel line connector <2 and 3> or damage to the connector may occur.
- Damage to the fuel line connector(s) due to improper removal/installation may cause the connector to not fasten securely upon reinstallation, causing a leak. A damaged fuel line connector on the front or rear suction pump line requires replacement of the FUEL TANK.
- Consequential damage to the fuel tank due to connector damage from improper removal/installation is not covered under this campaign.

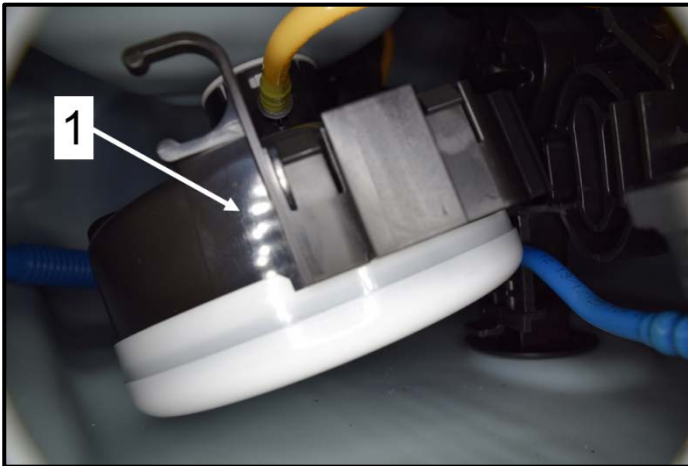
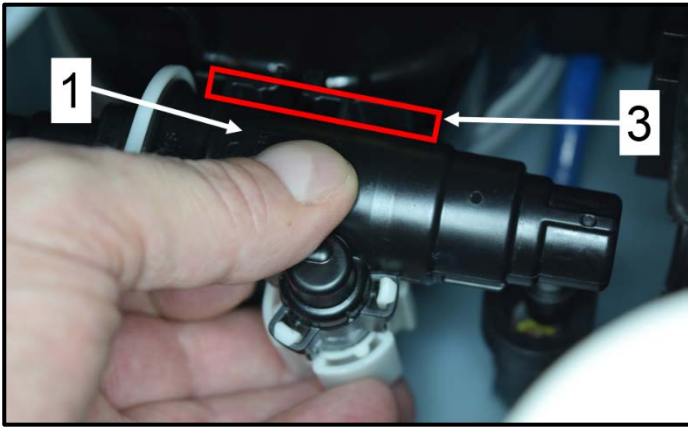

- Remove the suction pump <1> off the retainer bracket <3>:
 - Slightly rotate suction pump <1> away from the bracket <3>
 - Remove the pump <1> from the fuel tank by gently rocking it back and forth between the fingers and thumb.
 - Use caution not to damage the attached front suction line.

- Take care that the Liquid-Vapor Separator Assembly <1> does not come off of its attachment bracket when removing the Suction Jet Pump.

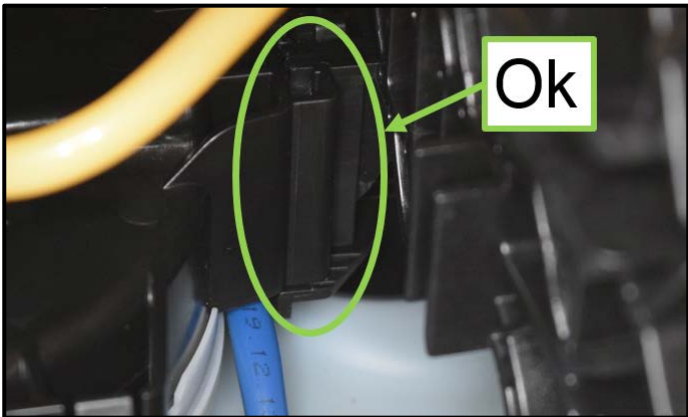
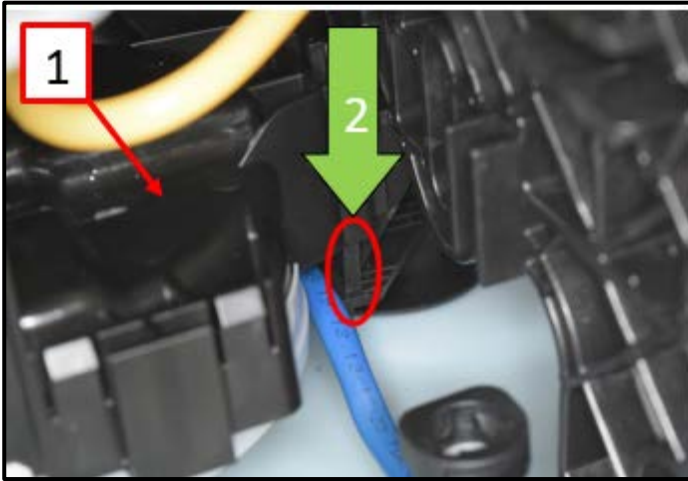
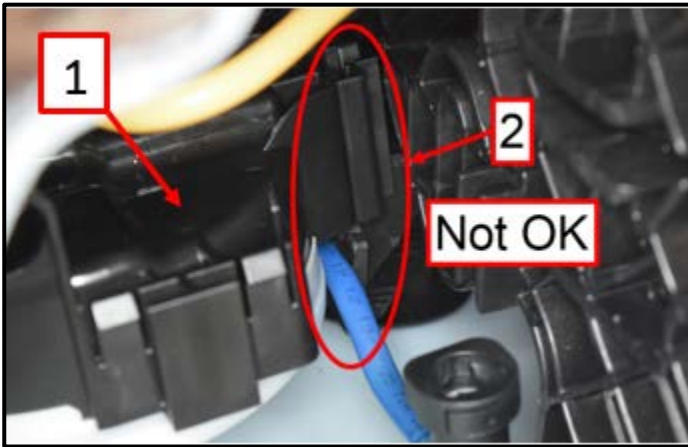

NOTE

Risk for repeat repair!

- If the Liquid-Vapor Separator <1> comes loose and is not reinstalled onto the mounting bracket, a customer comeback for rattling in the fuel tank, or EVAP system faults may occur.
- The Liquid-Vapor Separator <1> can be reinstalled onto its mounting bracket <2>.
- Replacement of the fuel tank for the Liquid-Vapor Separator dislodging from the mounting bracket are not covered under this campaign.

- If the Liquid-Vapor Separator Assembly <1> comes off the mounting bracket during suction pump removal:
 - Snap the Liquid-Vapor Separator <1> back into place by realigning it with the mounting bracket.
 - Push down on the Liquid-Vapor Separator to reengage the clip <2>.

- When correctly installed, the Liquid-Vapor Separator clip will be secured into its mounting bracket as shown.

NOTE

- The fuel tank does NOT require replacement if the Liquid-Vapor Separator Assembly is dislodged from its mounting bracket during removal of the Suction Jet Pump.
- Consequential damage for fuel tank replacement is not covered under this campaign for dislodged Liquid-Vapor Separator Assemblies.

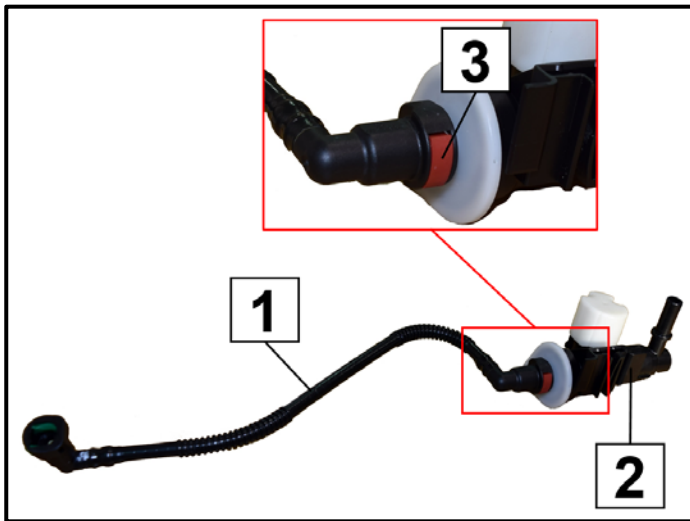

- Disconnect the front suction line <1> from the suction pump:
 - Push the front suction line <1> further onto the suction pump <2>.
 - Press the release <3> with the thumb, then pull the front suction line <3> off of the suction pump <2>.
- Transfer the front suction line <1> from the old suction pump <2> to the new suction pump, ensuring that the locking of the retention clip <3> is felt and/or heard.

i TIP

- The red colored connector <3> on the front suction line connects to the suction pump.
- The green colored connector on the front suction line connects to the fuel delivery unit.

! NOTE

Risk for repeat repair!

- Do not use pliers or other tools on the fuel line connector <3> or damage to the connector may occur.
- Damage to the fuel line connector due to improper removal/installation may cause the connector to not fasten securely upon reinstallation, causing a leak. A damaged fuel line connector on the suction pump line requires replacement of the FUEL TANK.
- Consequential damage to the fuel tank due to connector damage from improper removal/installation is not covered under this campaign.

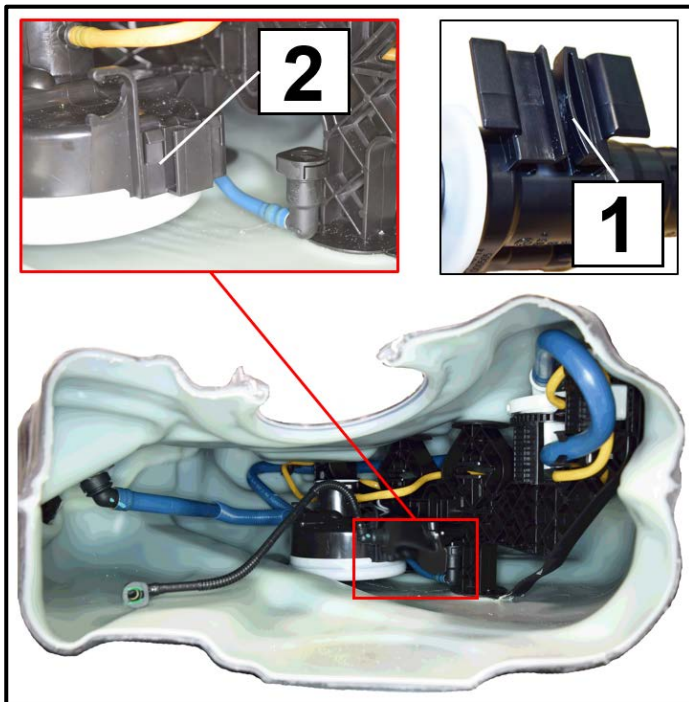

- Insert the new suction pump <1> into the fuel tank.
- Align the retention clip on the new suction pump <1> to the bracket <2> on the liquid-vapor separator.
- Slide the new suction pump <1> downward onto the bracket <2>.
- Ensure that the pump is secured firmly on the bracket <2>.

Part Number	Part Description
5Q0-201-029	Suction Pump

NOTE

Use caution not to damage the attached front suction line during installation.

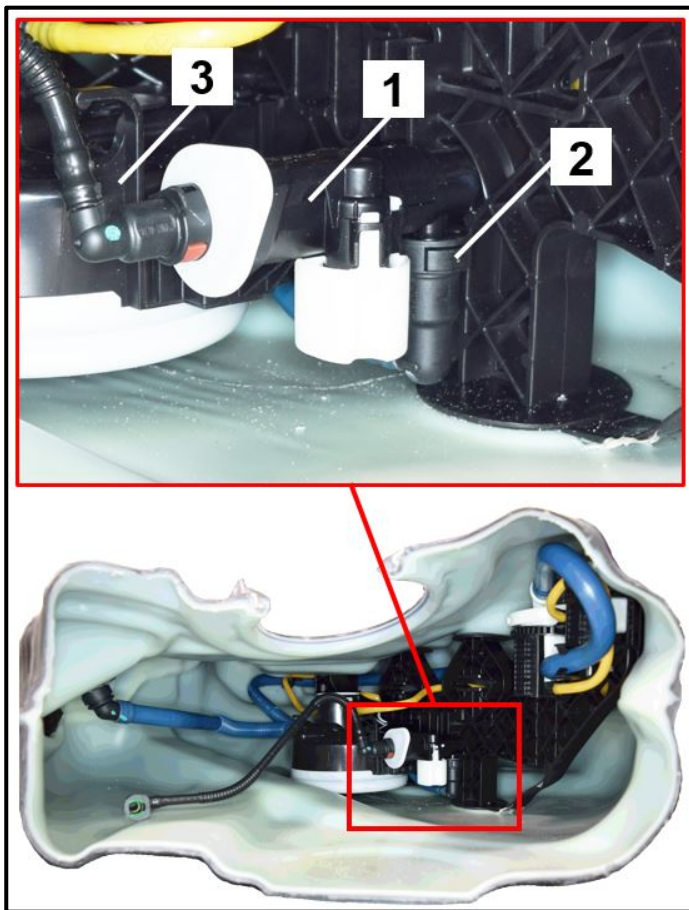

- Reconnect the rear suction line <2> to the suction pump <1>, ensuring that the locking of the retention clip is felt and/or heard.
- Ensure that the front suction line <3> and rear suction line <2> are firmly seated and secure by gently pulling the lines away from the suction pump.

NOTE

Risk for repeat repair!

- Do not use pliers or other tools on the fuel line connectors <2 and 3> or damage to the connector may occur.
- Damage to the fuel line connector(s) due to improper removal/installation may cause the connector to not fasten securely upon reinstallation, causing a leak. A damaged fuel line connector on the front or rear suction pump line requires replacement of the FUEL TANK.
- Consequential damage to the fuel tank due to connector damage from improper removal/installation is not covered under this campaign.

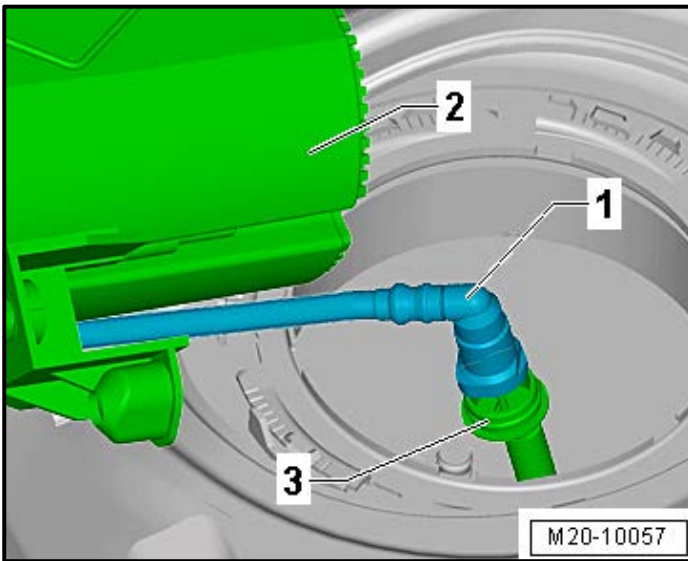

NOTE

When reconnecting fuel lines, ensure that the locking of the retention clip is felt and/or heard.

- Carefully align the fuel delivery unit <2> to the fuel tank and reconnect the fuel line <1> to the front suction line <3>.

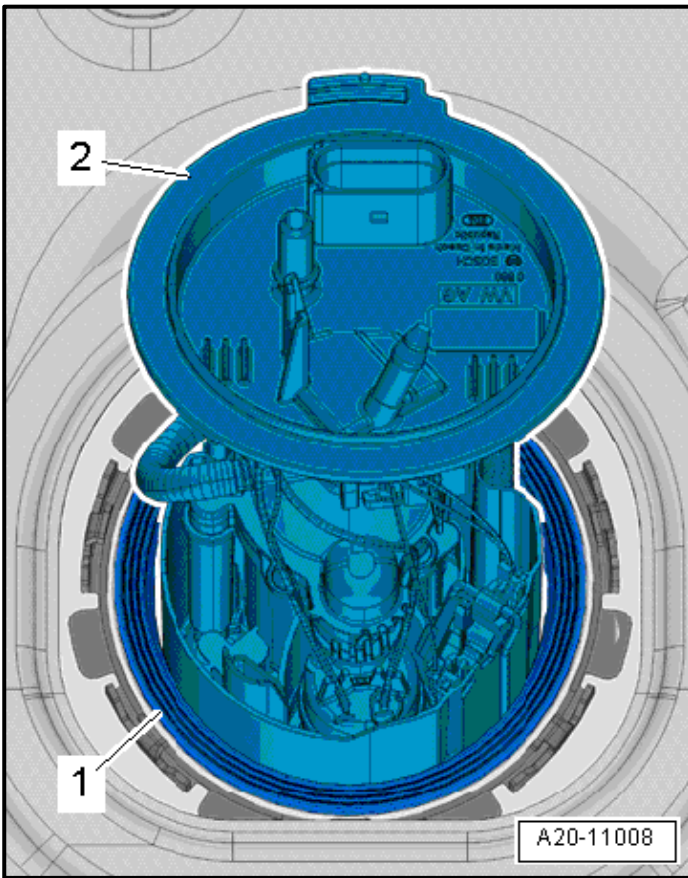

CAUTION

Risk for repeat repair!

- Be careful not to bend the fuel level sensor when installing the fuel delivery unit.
- Consequential damage to the fuel level sensor is not covered under this campaign.
- Carefully install the dry fuel delivery unit seal <1> into the opening in the fuel tank.

Part Number	Part Description
1J0-919-133-B	Seal

NOTE

The fuel delivery unit seal must be installed dry.

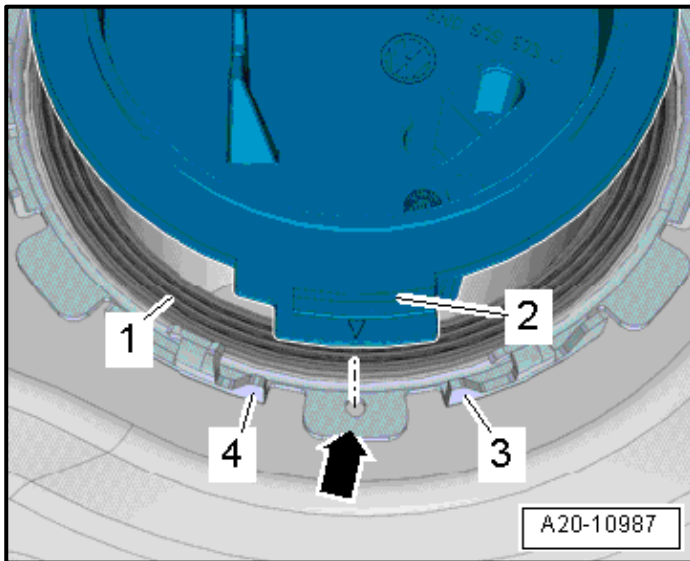

NOTE

When inserting the sealing flange, the seal must not be damaged or crushed.

- Push the sealing flange <2> down against the spring force.
- Bring the sealing flange into its installation position.

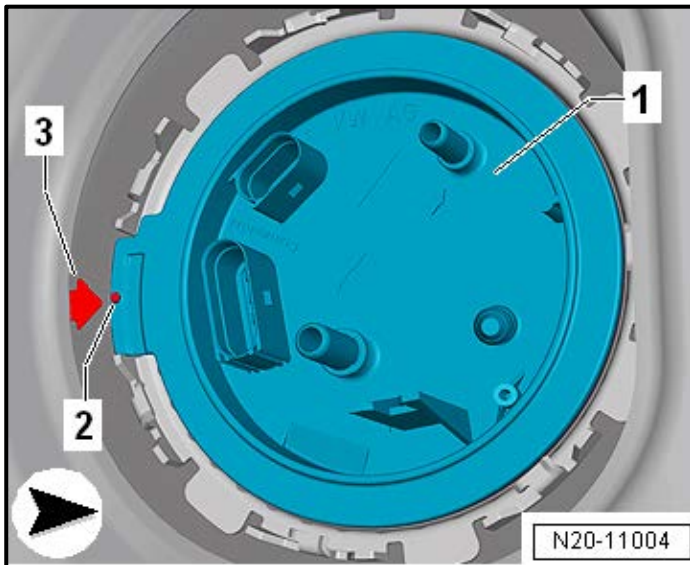

- The arrow <3> on the fuel tank must point to the mark <2> on the sealing flange <1>.



- Using the -T10202-, tighten the locking ring to 110 Nm.

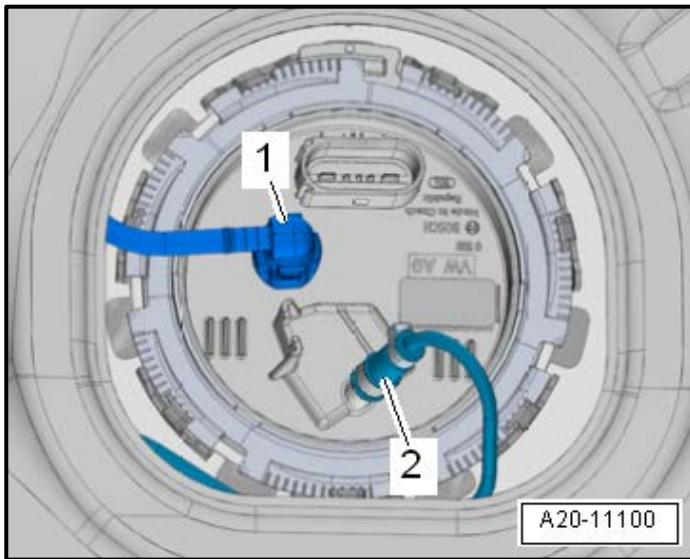

- Attach the fuel line <1> to the sealing flange until it clicks into place.
- If equipped, install the fuel line <2> to the Metering Pump -V54- for the parking heater on the sealing flange.

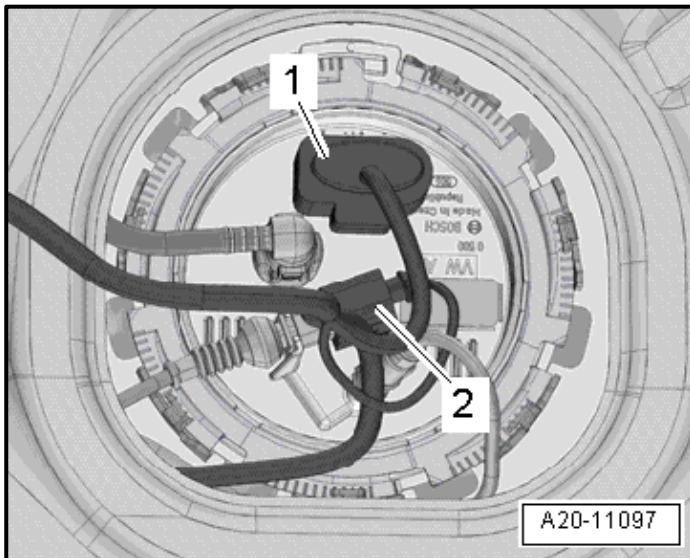

- Connect the connector <1>.
- If equipped, engage the connector <2> for the parking heater Metering Pump -V54- on the sealing flange.
- Gently pull on the connectors to make sure they are secure.

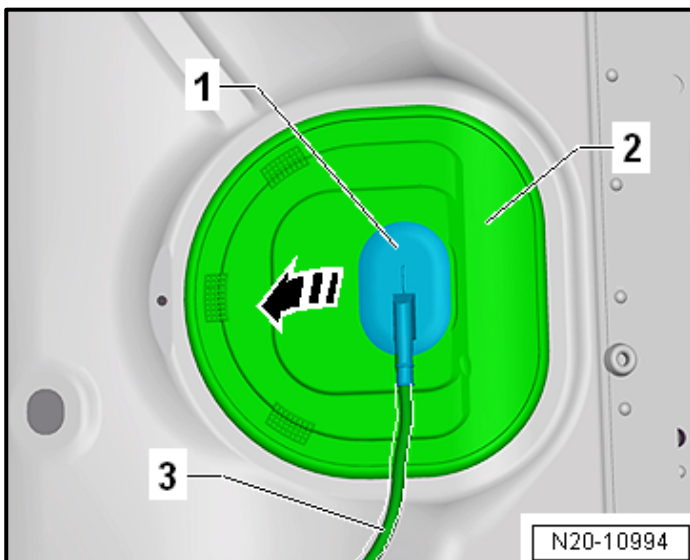

- Reattach the grommet <1> into the cover <2>.

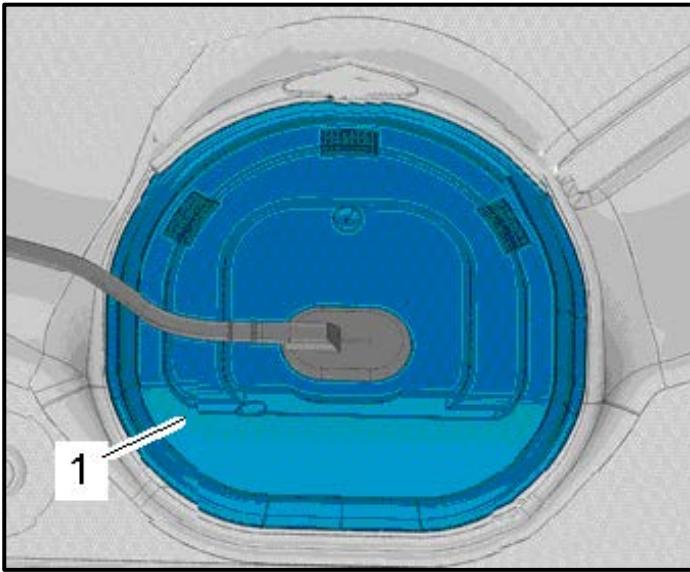

- Reattach the sealing flange cover <1>.

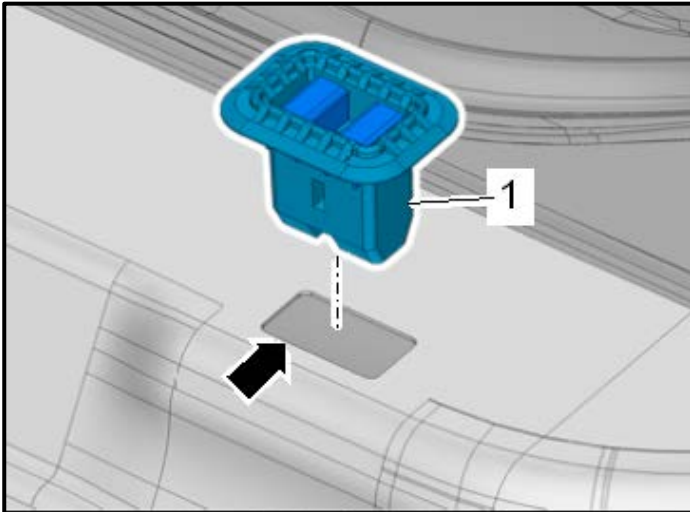

- Prior to reinstalling the rear seat, remove the grommets <1> and check the body openings <arrow> for deformations.
 - If deformation is found, readjust the panel with a plastic hammer.
- Lift the carpet <2> and press in the mounting grommets <1> until they engage audibly in body opening <arrow>.
- Ensure the carpet does not cover the grommet.

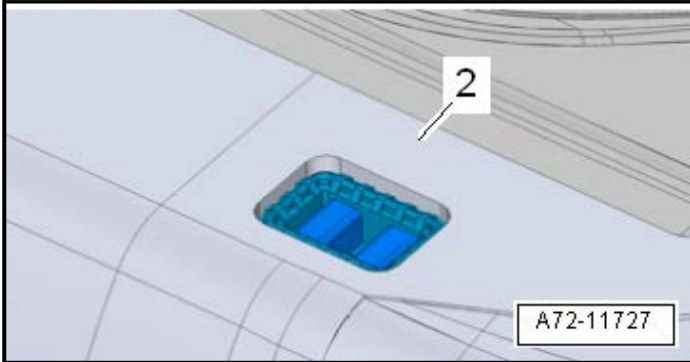

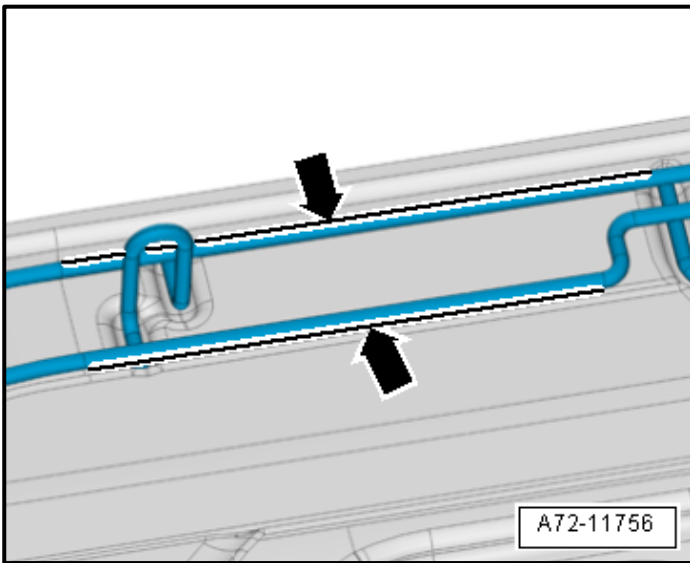

- Check if the wire frame is aligned in the marked area <arrows> before installing the rear bench seat.
- If the wire frame is bent, bend it back far enough until it is realigned.

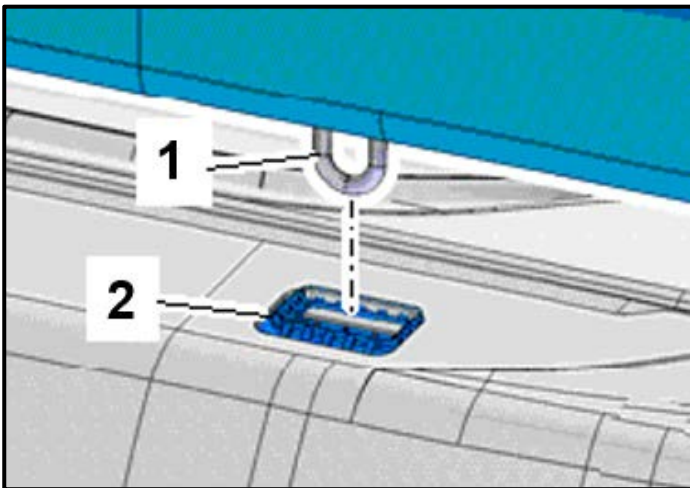

- Install the rear bench seat and push the wire hooks <1> into the mounting grommets <2>.

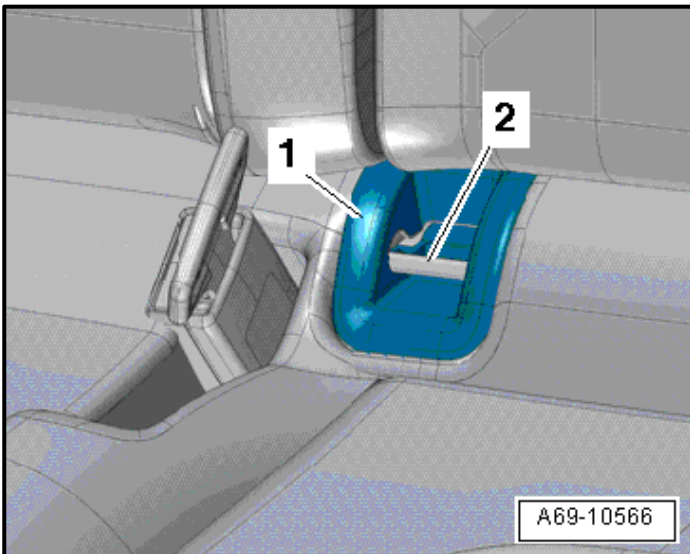

- Reinstall the guides <1> to the LATCH child seat anchors <2>.

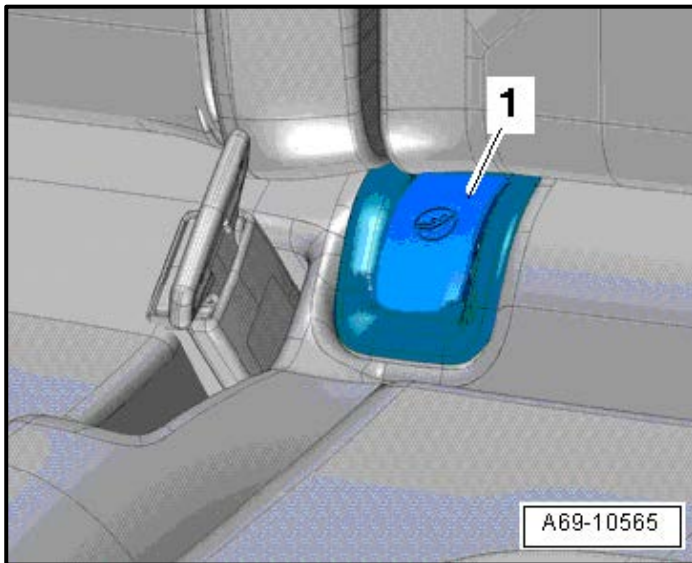

- Reinstall the covers <1> to the LATCH child seat anchors.

CAUTION
Edges on the child seat anchor cover may be sharp.

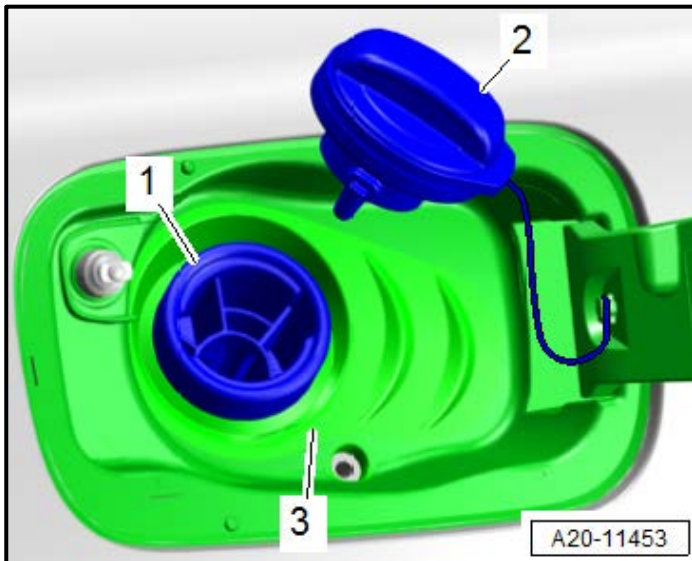

- Open the fuel door and remove the fuel cap <2>.
- Refill the fuel tank with the same amount of fuel removed prior with the -VAS 5190- Fuel Extraction Unit.
- Verify using the sightglass on the side of the -VAS 5190- Fuel Extraction Unit that the fuel tank was filled with the same amount of fuel that was extracted before reconnecting the battery.

NOTE
Risk for repeat repair!
Failing to fill the fuel tank with the same amount of fuel that was extracted can result in fuel level sending unit faults, or fuel gauge inaccuracies. Additional diagnostic time required to perform a capacitive discharge or remove fused power to the instrument cluster to clear these faults or inaccuracies are NOT covered under this campaign.

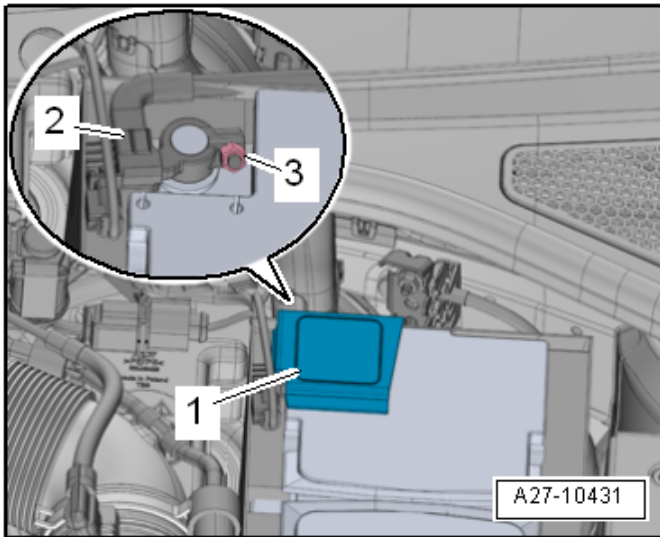

- Deisolate and then reconnect the negative battery terminal <2> to the battery post.
- Tighten the nut <3> to 6 Nm.



- Switch the ignition ON.
- Attach an appropriate VAS tester to the vehicle.
- Clear all DTCs.
- Cycle the ignition multiple times and check for fuel leaks.
- Reset customer convenience basic settings (i.e. one touch windows, instrument cluster clock, etc.).

Proceed to section C.

Section C – Campaign Completion Label

Install Campaign Completion Label

- Fill out and affix Campaign Completion Label, part number CAMP 010 000, next to the vehicle emission control information label.

i TIP

Ensure Campaign Completion Label does not cover any existing label(s).

- **Proceed to Section D.**

Section D - Parts Return/Disposal

Properly store (retain), destroy or dispose of removed parts in accordance with all state/province and local requirements, unless otherwise indicated and/or requested through the Warranty Parts Portal (WPP).