



Service Bulletin

American Honda Motor Co., Inc.

SAFETY RECALL

2015-2016 CBR300R/RA, CB300F CRANKSHAFT REPLACEMENT

Honda is announcing a SAFETY RECALL of model year 2015 through 2016 CBR300R/RA and CB300F motorcycles to replace a potentially defective crankshaft on affected vehicles. If the connecting rod bearing retainer breaks, the engine may stall and/or not restart.

Safety Consequence

An engine that stalls while riding increases the risk of a crash.

CUSTOMER NOTIFICATION

In early September, 2016 American Honda will send a notification letter to owners of affected 2015 through 2016 model year CBR300R/RA and CB300F motorcycles informing them of this Safety Recall.

AFFECTED UNITS

2015 CBR300R/RA - All
2015 CB300F - All
2016 CBR300R/RA - All
2016 CB300F - All

DEALER INVENTORY

Effective July 5, 2016, YOU MUST NOT SELL any 2015 through 2016 CBR300R/RA or CB300F motorcycle until it has been repaired according to the REPAIR PROCEDURE in this Service Bulletin.

- **iN eResponsibility Report** will show the affected units in your dealership's inventory.
- To determine if a specific VIN is affected, use **iN Unit Information**.

REPAIR VERIFICATION

Before you begin the Repair Procedure, check if the recall has been performed on the affected unit by looking for a punch mark on the frame as shown in the IDENTIFICATION section of this Service Bulletin.

- If there is a punch mark at the specified location:
 - No further action is necessary.
- If there is no punch mark:
 - You must proceed with the REPAIR PROCEDURE section of this Service Bulletin.

For any questions relating to REPAIR VERIFICATION, please contact your District Service Manager or TechLine.

REPAIR PROCEDURE

SERVICE MANUAL

Many steps of the Repair Procedure require following procedures in the Service Manual. Make sure to have the Service Manual at hand before starting this procedure.

Electronic Service Manuals are also available on **iN HISP** by following the path below and typing in the VIN or selecting the model and year, and selecting *Service Manual* from the *Select Subject* drop down list.

SERVICE > Service Publications > HISP

ENGINE REMOVAL

Remove the ENGINE by following the procedure on Page 15-4 of the Service Manual.

- Disconnect the negative battery cable.
- Save the drained engine oil in a clean container for debris inspection.
- Save the drained coolant in a clean container for reuse.

ENGINE DISASSEMBLY

1. Separate the CRANKCASE by following the procedure on Page 14-6 of the Service Manual.
 - It is not necessary to remove the neutral safety switch.
2. Remove the CRANKSHAFT by following the procedure on Page 14-7 of the Service Manual.
3. Inspect the engine oil, inside surfaces of the engine cases, and the engine oil strainer screen for solid metallic debris. If found, stop the repair and call TechLine.
4. Inspect the connecting rod bearing area. If the thrust washers are cracked or broken, or if the connecting rod bearing is seized, stop the repair and call TechLine.

MAIN JOURNAL BEARING INSPECTION

Check both main journal bearings for unusual wear, damage or peeling.

Inspect the bearing surface according to the graphic as shown.

- If the bearing shows Silver color:
It is not necessary to replace the main journal bearings.
- If the bearing shows Copper color:
Replace the main journal bearings as follows.

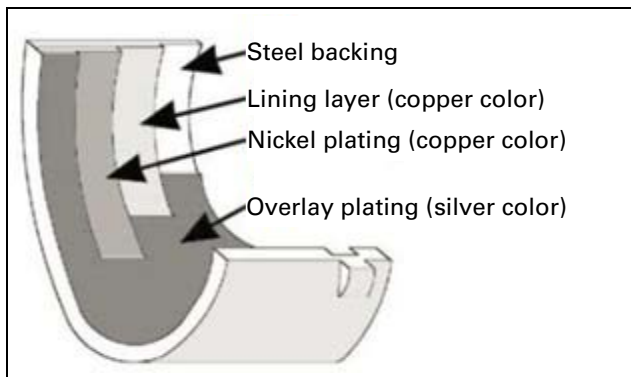

MAIN JOURNAL BEARING REPLACEMENT

NOTE: Only replace the main journal bearings if copper color is showing.

1. Record the bearing support I.D. code.

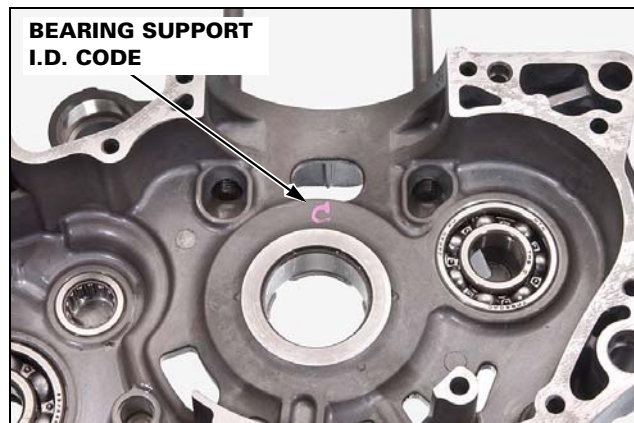

2. Select the correct main journal bearing from the chart as shown.

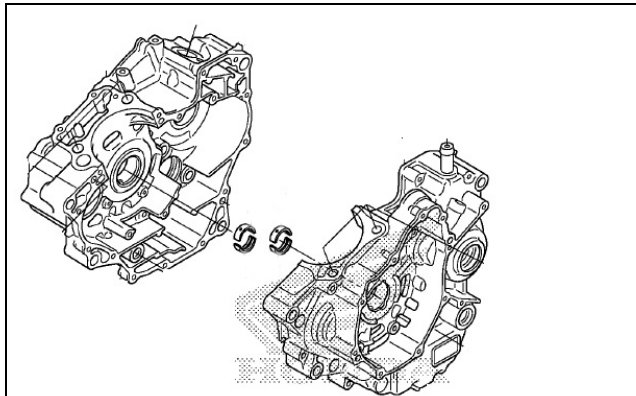

Bearing Support I.D. Code		Main Journal Bearing - Code (Color) / Part Number
A	➔	C (Brown) / 13314-K33-D01
B	➔	B (Black) / 13313-K33-D01
C	➔	A (Blue) / 13312-K33-D01

NEW

3. Once the correct bearing has been selected, order the bearings from TechLine.

- Bearings are not included in the parts kit.

4. Assemble the special tools and crankcase onto a hydraulic press as shown.

TOOLS:

Driver, 30 x 36 mm 07HMF-KR10101
Base, 42 mm 07GAF-SD40200

- Special tools are available through Honda parts channels, and may be available for loan. Call TechLine for loan availability.

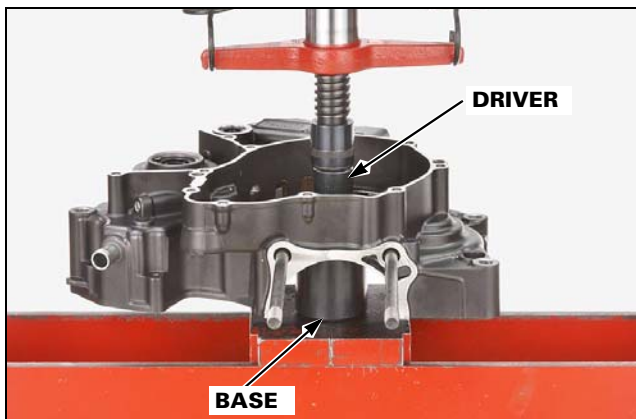

5. Press the main journal bearings toward the inside of the crankcase as shown.

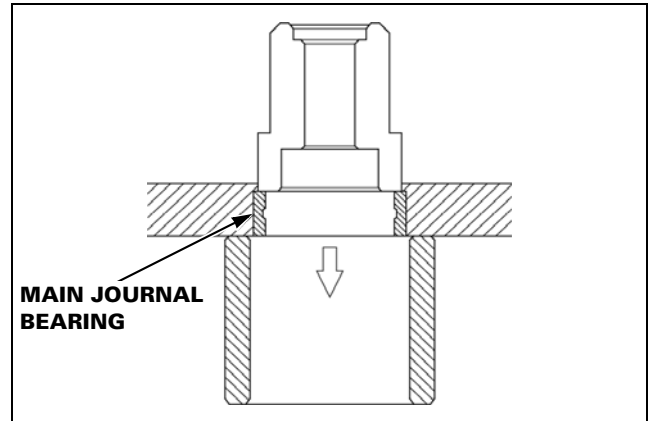

BEARING INSTALLATION

Install the main journal bearings by following the BEARING INSTALLATION procedure on Page 14-12 of the Service Manual.

- Refer to the [February 2014 edition of The Wrench](#) for bearing installation tool use.

TOOLS:

Base, 42 mm 07GAF-SD40200
Metal installer set 070MF-KYJA100

COUNTERSHAFT OIL SEAL REPLACEMENT

1. Remove the snap ring.
2. Remove the countershaft oil seal from the left crankcase.
3. Apply grease to the lips of a new countershaft oil seal.
4. Install the countershaft oil seal with its marked side facing up.
5. Install the snap ring securely in its groove.

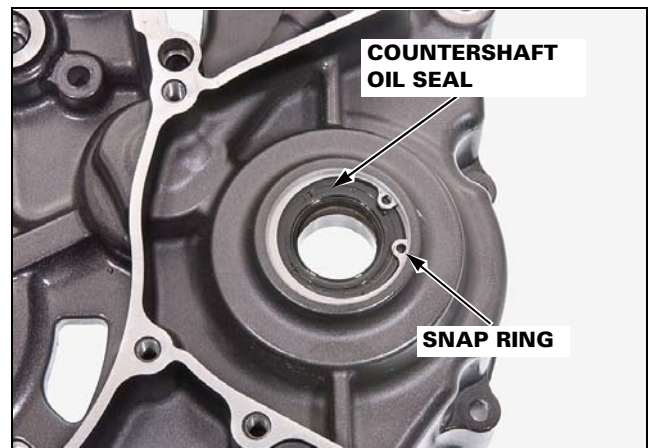

ENGINE ASSEMBLY

Assemble the engine with the gaskets and seals supplied in the parts kit.

1. Assemble the CRANKCASE ASSEMBLY by following the procedure on Page 14-23 of the Service Manual.
2. Install the STARTER MOTOR by following the procedure on Page 6-5 of the Service Manual.
3. Install the FLYWHEEL by following the procedure on Page 13-7 of the Service Manual.
4. Install the PRIMARY DRIVE GEAR by following the procedure on Page 12-22 of the Service Manual.
5. Install the OIL PUMP by following the procedure on Page 9-7 of the Service Manual.
6. Install the GEARSHIFT LINKAGE by following the procedure on Page 12-19 of the Service Manual.
7. Install the CLUTCH by following the procedure on Page 12-15 of the Service Manual.
8. Install the CYLINDER/PISTON by following the procedure on Page 11-8 of the Service Manual.
9. Install the CYLINDER HEAD by following the procedure on Page 10-21 of the Service Manual.
10. Install the CAMSHAFT by following the procedure on Page 10-11 of the Service Manual.
11. Rotate the crankshaft by hand two revolutions and confirm proper cam timing.
12. Install the engine into the frame by following the ENGINE INSTALLATION procedure on Page 15-6 of the Service Manual.
13. Install the DRIVE SPROCKET COVER by following the procedure on Page 2-16 of the Service Manual.
14. Install the EXHAUST SYSTEM by following the procedure on Page 2-24 of the Service Manual.
15. Install the O2 SENSOR CAP by following the procedure on Page 4-32 of the Service Manual.

16. Install the THROTTLE BODY by following the procedure on Page 7-18 of the Service Manual.
17. Add 1.9 qt. of engine oil to the engine.
18. Fill and bleed the cooling system with the saved coolant following the procedure on page 8-6 of the Service Manual.
19. Install the removed body panels in the reverse order of removal.
20. Check the engine oil level and engine coolant level by following the procedures in the MAINTENANCE section of the Service Manual.

IDENTIFICATION

After the repair procedure is complete, apply a punch mark on the frame behind the color label located under the passenger seat, as shown.

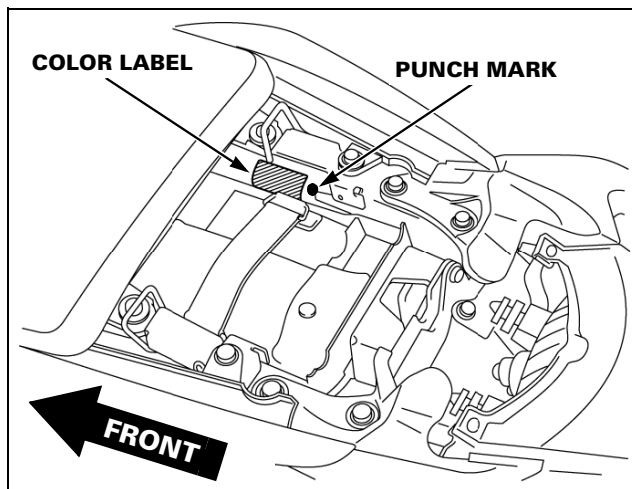

PARTS INFORMATION

Parts will be allocated initially, based upon dealer inventory and sales.

REQUIRED PARTS

CBR300R/RA and CB300F Crankshaft Replacement Parts Kit

P/N 06130-K33-305

Kit Contents:

NEW

- Main journal bearings are not included in the parts kit. These must be ordered from TechLine, and only if needed.

PART NAME	QTY.	REFERENCE
Crankshaft comp	1	
Gasket, R.	1	Crankcase cover
Gasket, L	1	Crankcase cover
Gasket, exhaust pipe	1	
Washer, drain 12 mm	1	Engine oil drain
Gasket, cylinder head	1	Cylinder head cover
Gasket, cylinder head	1	Cylinder head
Gasket	1	Tensioner lifter
O-ring 1.5 mm x 9.5 mm	1	Lifter assembly, tensioner
Gasket, cylinder	1	
Element, oil filter	1	
Gasket	1	Oil filter cover
O-ring 11.8 mm x 1.9 mm	5	Pin A, dowel of R. cover (1) Valve assembly, relief (2) Pump assembly, oil (1) Pin A, dowel, of R. crankcase (1)
O-ring 9.8 mm x 2.4 mm	2	Pipe, water
O-ring 17.8 mm x 1.9 mm	1	Collar, oil path, 18 mm
Washer 6.5 mm	1	Cover, water pump
Nut, special 16 mm	1	Clutch
O-ring 13.8 mm x 2.5 mm	1	Cap, A.C. generator
O-ring 30 mm	1	Cap, L. cover 30 mm
Gasket, oil pump	1	
Rubber, mounting	2	Cover assembly, cylinder head
Bolt-washer 6 mm x 25 mm	1	Tensioner, cam chain
Bolt, hex 6 mm x 20 mm	1	Plate, gearshift drum stopper
Pivot	1	Shift drum stopper arm
O-ring 24.4 mm x 3.1 mm	1	Motor assembly, starter
Key 25 mm x 18 mm	1	Crankshaft, woodruff
Oil seal 14 mm x 22 mm x 5 mm	1	Spindle, gearshift
Oil seal 22 mm x 36 mm x 5 mm	1	Countershaft
Clip 17 mm	2	Piston pin

CLAIM INFORMATION

This Safety Recall will be in effect indefinitely, regardless of the date of vehicle purchase.

Reminder: Honda Warranty Policy states that recall warranty claims must be submitted within 30 days of the repair order open date. After completing the Service Bulletin repair procedure, submit one warranty claim per unit with the following information:

TEMPLATES

Crankshaft Replacement: KB9A
Flat Rate Time: 5.9 hours

Crankshaft and Main Journal Bearing Replacement: KB9B
Flat Rate Time: 5.9 hours

DEALER SUPPORT

TECHNICAL QUESTIONS

If you have any technical questions relating to the inspection procedure or parts information, please contact:

Motorcycle TechLine:
iN > Service > TechLine > TechLine Connect
Or call (800) 421-1900, option 9

WARRANTY QUESTIONS

If you have any warranty administration questions relating to warranty claim templates, repair verification discrepancies, and claim filing procedures, please call:

Motorcycle Warranty, (800) 421-1900, option 7

TEXT OF CUSTOMER LETTER

August 2016

NHTSA Recall 16V-528

IMPORTANT SAFETY RECALL

This notice applies to your motorcycle.

Dear CB300F or CBR300R/RA Owner:

This notice is sent to you in accordance with the National Traffic and Motor Vehicle Safety Act.

WHAT IS THE REASON FOR THIS NOTICE?

Honda has decided that a defect which relates to motor vehicle safety exists in 2015-2016 model year CB300F and CBR300R/RA motorcycles. A manufacturing issue may cause the connecting rod bearing retainer to wear prematurely, corrode and break, which may cause the engine to stall and/or not restart. An engine that stalls while riding increases the risk of a crash.

WHAT WILL HONDA DO?

The crankshaft will be replaced, free of charge.

WHAT SHOULD YOU DO?

At the time of this notice remedy parts will be limited. Please contact any authorized Honda motorcycle dealer about parts availability and to schedule an appointment to have your motorcycle's crankshaft replaced, **at no cost to you**.

Replacing your crankshaft will take approximately 5.9 hours to complete; however, please ask your dealer for the specific time your motorcycle will need to be at the dealership.

For assistance locating a Honda motorcycle dealer, you may call Honda Motorcycle Customer Support at: 1-866-784-1870 or use the "find a dealer" option on www.powersports.honda.com

CHECK YOUR MOTORCYCLE FOR OPEN RECALLS

To check your motorcycle's eligibility for repair under this or any recall, please access the **Honda Recall Lookup** tool at www.powersports.honda.com/recalls.aspx and enter your Vehicle Identification Number (VIN).

OWNER INFORMATION

You received this recall notice because government regulations require that notification be sent to the last known owner of record. Our records are based primarily on state registration and title data, which indicate that you are the current owner of this motorcycle. If this is not the case, or if any of the information is incorrect, please complete, sign and return the Information Change Card and we will update our records. If you are a lessor of this motorcycle, federal regulations require you to forward this notice to your lessee within ten days.

DO YOU STILL HAVE MORE QUESTIONS?

Should you have any questions about this recall, please contact your authorized Honda motorcycle dealer. Should you need additional assistance, you may contact Honda Motorcycle Customer Support at 1-866-784-1870.

If you believe that American Honda or the dealer has failed or is unable to remedy the defect in your motorcycle, free of charge, within a reasonable period of time (within 60 days from the date you first contacted the dealer for a repair appointment), you may submit a complaint to the Administrator, National Highway Traffic Safety Administration, 1200 New Jersey Ave., SE, Washington, DC 20590. Alternatively, you may call the NHTSA's toll-free Safety Hotline at 888-327-4236 (TTY 800-424-9153), or go to: www.safercar.gov

WHAT TO DO IF YOU ALREADY HAD YOUR MOTORCYCLE REPAIRED FOR THIS ISSUE

If you previously paid to have the crankshaft replaced due to this condition, you may be eligible for reimbursement. Refer to the attached Instructions for Reimbursement for the eligibility requirements and the reimbursement procedure.

We apologize for any inconvenience this recall may cause you.

Sincerely,

**American Honda Motor Co., Inc.
Motorcycle Division**

Campaign #KB9 / Service Bulletin: CBR300R/CB300F#1