

AG04 - Checking Fastening Screws for Seat Belt Mount and Belt Reel and Replacing if Necessary (Recall Campaign)

Vehicle type: **918 Spyder**

Model Year: **2015**

Subject: **Fastening screws for three-point seat belt**

Issue: **In the parts catalogue for the 918 Spyder, the locations for using the screws for securing the seat belt mount and belt reel were displayed incorrectly.**

Once removed, the screws used to secure the seat belt mount and belt reel must not be re-used. New fastening screws will therefore be ordered in accordance with the parts catalogue.
 We cannot rule out the possibility that due to the mix up in the allocation in the parts catalogue, the wrong fastening screws may have been used for these locations in the Porsche Centre when carrying out assembly work, such as removing and installing seats. In this case, the restraint function of the seat belt system may be impaired in the event of an accident.

Remedial action: Check fastening screws for seat belt mount and belt reel and replace them if necessary.



Information

The vehicle must be checked for defects and damage (damage to paintwork, missing parts, etc.) **each time** it is handed over, transferred or delivered. Confirmation that the vehicle is in good condition or details of any damage to the vehicle must be documented and archived for feedback purposes.

Service Level: **This campaign must be carried out by a Service Level 2 Porsche Centre.**

Service Level 0 Porsche Centres are **not** authorised to carry out this campaign.
 In accordance with the service concept for the 918 Spyder, the vehicle must be transferred to the nearest Service Level 2 Porsche Centre in order to carry out this campaign.

In this case, please contact the nearest Service Level 2 Porsche Centre and arrange for the transfer of the vehicle and implementation of the measure.

Information on invoicing for the transfer of the vehicle can be found under ⇒ *Technical Information 'AG0400 Warranty processing'* at the end of this document.

Affected Vehicles: Only the vehicles assigned to the campaign (see also PIWIS Vehicle information). This campaign affects 306 vehicles in North America.

Parts required

No parts are required for **checking** the fastening screws (**Scope 1**).

Parts required for **replacing** the fastening screws (**Scope 2**):

Parts Info: **NOTE:** PARTS WILL NOT BE AUTOMATICALLY ALLOCATED TO YOUR DEALERSHIP. ALL PARTS MUST BE ORDERED VIA A PTEC/PAV.

Part No.	Designation – Use	Qty.
999 075 057 09	⇒ Fastening screw, hexagon-head 7/16-20UNF – Seat belt mount	2 ea. * (only if required)
N 989 260 01	⇒ Fastening screw, multiple-tooth V60428 – Belt reel	2 ea. * (only if required)
999 073 312 09	⇒ Fastening screw, M10 x 30.6 – Front seat rail	4 ea. * (only if required)
900 817 003 02	⇒ Fastening nut, M10 – Rear seat rail	4 ea. * (only if required)
991 803 295 00	⇒ Cap – Seat belt mount	2 ea. * (only if required)

* The number of fastening parts required depends on the result of the check and can therefore vary.

Required tools

Tools: Tools required for **checking fastening screw for belt reel**:

- Plastic wedge
- Flashlight

Additional tools required if **fastening screw for seat belt mount and/or belt reel must be replaced**:

- Torque wrench, 6 - 50 Nm (4.5 - 37 ftlb.), e.g. **V.A.G 1331 - Torque wrench, 6-50 Nm (4.5-37 ftlb.)**
- **9014 - Protective cover** for carbon fiber door entrance sill protection and center console trim protection.

Checking fastening screws for seat belt mount and belt reel

Overview:

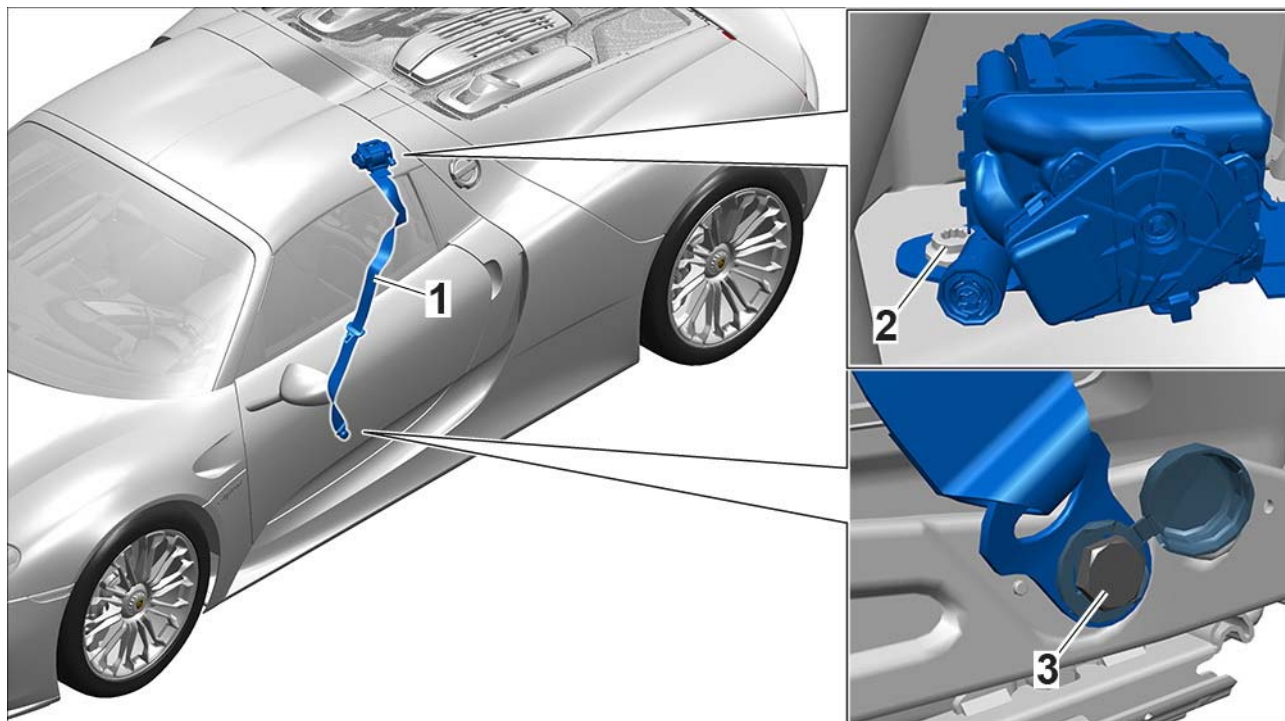

Overview of three-point seat belt

- 1 – Three-point seat belt
- 2 – Fastening screw for belt reel (multiple-tooth)
- 3 – Fastening screw for seat belt mount (hexagon-head)

Procedure:



Information

The procedure described here for checking the fastening screws on the left-hand side of the vehicle must always be carried out on the **left and right-hand side of the vehicle**.

1 Preparatory work:

- 1.1 Switch off ignition and remove ignition key.
- 1.2 Remove roof panels.
 ⇒ 918 Spyder Driver's Manual, chapter "Windows, Roof Panels", section on "Removable roof panels"
- 1.3 Remove trim panels for roll-over bar ⇒ *Workshop Manual '708119 Removing and installing trim panel for roll-over bar'*. Move seat to forward position first.

- 1.4 Remove rear covers ⇒ *Workshop Manual '705319 Removing and installing rear cover'*. It is not necessary to remove the seat belt mount bolt in the seat at this point in the repair; unless it has already been identified as being the incorrect bolt. **Ensure that the loosened rear cover panels do not scratch interior trim panels and seat covers.**

2 **Check fastening screws for seat belt mount and belt reel.**

2.1 **Seat belt mount:**

Unclip cap ⇒ *Checking fastening screw for seat belt mount -1-* on seat belt mount ⇒ *Checking fastening screw for seat belt mount -3-* and perform a visual inspection to see which type of fastening screw is installed on the seat belt mount.

- If the **hexagon-head fastening screw** ⇒ *Checking fastening screw for seat belt mount -2-* is installed on the seat belt mount ⇒ *Checking fastening screw for seat belt mount -3-*, the **fastening screw is correct** and does not have to be replaced. Then clip in the cap again and **continue with Step 2.2**
- If the **multiple-tooth fastening screw** ⇒ *Checking fastening screw for seat belt mount -4-* is installed on the seat belt mount ⇒ *Checking fastening screw for seat belt mount -3-*, this must be **replaced** by the **hexagon-head fastening screw** ⇒ **To do this, continue with Step 3.**

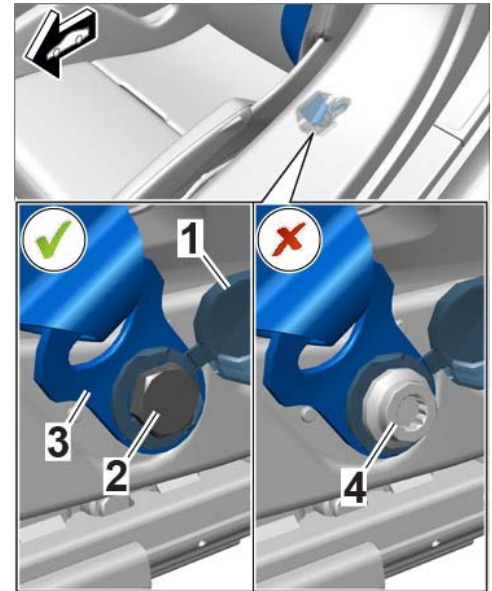

Checking fastening screw for seat belt mount

2.2 **Belt reel:**

Perform a visual inspection to see which type of fastening screw is installed on the belt reel.

- If the **multiple-tooth fastening screw** ⇒ *Checking fastening screw for belt reel -1-* is installed on the belt reel ⇒ *Checking fastening screw for belt reel -2-*, the fastening screw is correct and does not have to be replaced. ⇒ **Continue with Step 6.**
- If the **hexagon-head fastening screw** ⇒ *Checking fastening screw for belt reel -3-* is installed on the belt reel ⇒ *Checking fastening screw for belt reel -2-*, this must be **replaced** by the **multiple-tooth fastening screw** ⇒ **To do this, continue with Step 5.**

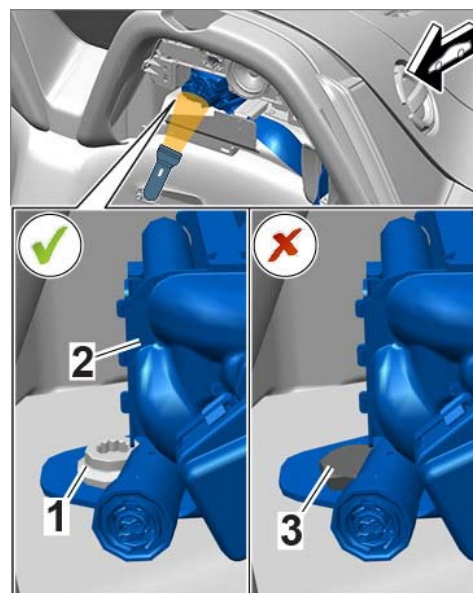

Checking fastening screw for belt reel

3 **Replace fastening screw for seat belt mount.**

- 1 – Cap
- 2 – Hexagon-head fastening screw
- 3 – Seat belt mount

3.1 **9014 - Protective cover** must be placed over the door sill. **Warning! The carbon fiber door entrance sill and the center console trim panels must not be scratched, chipped, cut or damaged in any way during this repair. Use specified 918 protective covers and scratch proof microfiber cloths to protect all exposed surfaces from damage that can be caused by tools and the seat tracks.**

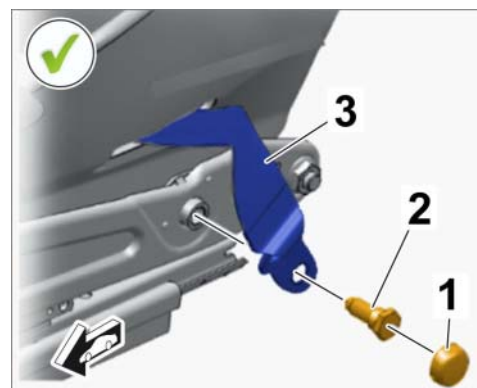

Fastening screw for seat belt mount

3.2 Loosen the front seat and carefully tilt it forward until the fastening screw on the seat belt mount is accessible ⇒ *Workshop Manual '720119 Removing and installing front seat'*.

There is no need to disconnect the battery in order to replace the fastening screw. **Warning! Do not allow the seat wiring harnesses to be strained and damaged if the seats are being tilted to access the seat belt mount bolt for replacement. Please have a second technician assist if it is necessary to tilt the seat to access the bolt for the replacement.**

3.3 Fit new **hexagon-head fastening screw**, Part No. 999 075 057 09 and **cap**, Part No. 991 803 295 00, on the seat belt mount.
For instructions, see ⇒ *Workshop Manual '720119 Removing and installing front seat'*.

Tightening torque 50 Nm (37 ftlb.)

- 3.4 Secure the front seat ⇒ *Workshop Manual '720119 Removing and installing front seat'*.
- 3.5 Remove protective covers from the vehicle.

4 Replace fastening screw for belt reel.

- 1 – Multiple-tooth fastening screw
- 2 – Belt reel

- 4.1 Remove loudspeaker bracket until the fastening screw on the belt reel is accessible ⇒ *Workshop Manual '691119 Removing and installing three-point seat belt'*
- 4.2 Fit new **multiple-tooth fastening screw**, Part No. N 989 260 01, on the belt reel. For instructions, see ⇒ *Workshop Manual '691119 Removing and installing three-point seat belt'*.

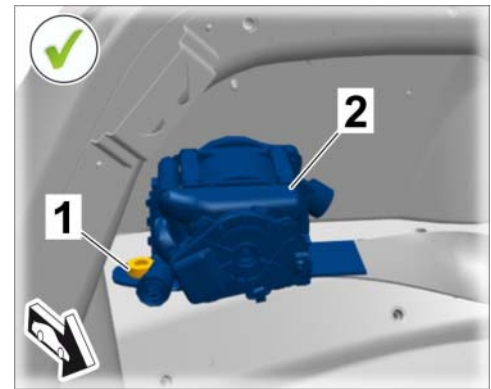
*Fastening screw for belt reel***Tightening torque 50 Nm (37ftlb.)**

- 4.3 Install loudspeaker bracket ⇒ *Workshop Manual '691119 Removing and installing three-point seat belt'*.

5 Concluding work:

- 5.1 Install rear covers ⇒ *Workshop Manual '705319 Removing and installing rear cover'*
- 5.2 Install trim panels for roll-over bar ⇒ *Workshop Manual '708119 Removing and installing trim panel for roll-over bar'*.
- 5.3 Install roof panels.
⇒ 918 Spyder Driver's Manual, chapter "Windows, Roof Panels", section on "Removable roof panels"
- 5.4 Operational test of seat belts.
Ensure seat belts latch completely, retract fully without binding, and are not twisted or facing incorrectly.
- 5.5 Check for seat belt or airbag warning displayed in the instrument panel.
Diagnose and repair any related malfunctions caused during this repair before returning the vehicle to the customer. Additional repairs that are not included in this campaign, must be claimed using a separate PQIS line.

- 6 Enter the campaign in the Warranty and Maintenance booklet.

End of remedial action.

Working time:

Checking fastening screws for seat belt mount and belt reel

Labor time: **55 TU**

Includes: Removing and installing cover for roll-over bar at the left and right
 Removing and installing rear cover at the left and right

Warranty Invoicing: ⇒ Damage Code AG04 99 000, Repair Code 1

Scope 2:

Scope 2 must be invoiced if **at least one fastening screw for the seat belt mount and/or for the belt reel** was replaced.

Working time:

Checking and replacing fastening screws for seat belt mount and belt reel

Labor time: **117 TU**

Includes: Removing and installing cover for roll-over bar at the left and right
 Removing and installing rear cover at the left and right
 Removing and installing loudspeaker cover at the left and right
 Loosening and securing front seat at the left and right

Parts required:

999 075 057 09	Fastening screw, hexagon-head 7/16-20UNF	2 ea. (as much as required)
N 989 260 01	Fastening screw, multiple-tooth V60428	2 ea. (as much as required)
999 073 312 09	Fastening screw, M10 x 30.6	4 ea. (as much as required)
900 817 003 02	Fastening nut, M10	4 ea. (as much as required)
991 803 295 00	Cap	2 ea. (as much as required)

Warranty Invoicing: ⇒ Damage Code AG04 99 000, Repair Code 2

Important Notice: Technical Bulletins issued by Porsche Cars North America, Inc. are intended only for use by professional automotive technicians who have attended Porsche service training courses. They are written to inform those technicians of conditions that may occur on some Porsche vehicles, or to provide information that could assist in the proper servicing of a vehicle. Porsche special tools may be necessary in order to perform certain operations identified in these bulletins. Use of tools and procedures other than those Porsche recommends in these bulletins may be detrimental to the safe operation of your vehicle, and may endanger the people working on it. Properly trained Porsche technicians have the equipment, tools, safety instructions, and know-how to do the job properly and safely. If a particular condition is described, do not assume that the bulletin applies to your vehicle, or that your vehicle will have that condition. See your authorized Porsche Dealer for the latest information about whether a particular technical bulletin applies to your vehicle. Part numbers listed in these bulletins are for reference only. Always check with your authorized Porsche dealer to verify the current and correct part numbers. The work procedures updated electronically in the Porsche PIWIS diagnostic and testing device take precedence and, in the event of a discrepancy, the work procedures in the PIWIS Tester are the ones that must be followed.

© Porsche Cars North America, Inc.

Dealership	Service Manager	Shop Foreman	Service Technician
Distribution	Asst. Manager	Warranty Admin.	Service Technician
Routing			

Dr. Ing. h.c. F. Porsche AG is the owner of numerous trademarks, both registered and unregistered, including without limitation the Porsche Crest®, Porsche®, Boxster®, Carrera®, Cayenne®, Cayman®, Macan®, Panamera®, Speedster®, Spyder®, 918 Spyder®, Tiptronic®, VarioCam®, PCM®, PDK®, 911®, RS®, 4S®, FOUR, UNCOMPROMISED®, and the model numbers and the distinctive shapes of the Porsche automobiles such as, the federally registered 911 and Boxster automobiles. The third party trademarks contained herein are the properties of their respective owners. Porsche Cars North America, Inc. believes the specifications to be correct at the time of printing. Specifications, performance standards, standard equipment, options, and other elements shown are subject to change without notice. Some options may be unavailable when a car is built. Some vehicles may be shown with non-U.S. equipment. The information contained herein is for internal authorized Porsche dealer use only and cannot be copied or distributed. Porsche recommends seat belt usage and observance of traffic laws at all times.

Printed in the USA