

Reference:

ITB17-038a

Date:

May 3, 2018

## VOLUNTARY SAFETY RECALL CAMPAIGN 2001 I30 AND 2002 – 2004 I35 FRONT PASSENGER AIR BAG INFLATOR

This bulletin has changed. Both the air bag module and inflator will be replaced.  
You must read the entire bulletin to properly perform this repair.  
Please discard previous versions of this bulletin.

**CAMPAIGN ID #:** R1622, R1704, R1706, R1713

**NHTSA #:** 15V-226, 15V-287, 16V-349

**APPLIED VEHICLES:** 2001 I30 (CA33)  
2002 – 2004 I35 (CA33)

**Check Service COMM or Dealer Business Systems (DBS)  
National Service History to confirm campaign eligibility.**

- Make sure the correct campaign ID # is being used.

### INTRODUCTION

Infiniti is conducting a Voluntary Safety Recall Campaign on certain specific model year 2001 I30 and 2002-2004 I35 vehicles to replace the front passenger air bag module and inflator. This service will be performed at no charge to the customer for parts or labor.

Takata has issued return packaging, shipping labels, documents, and directions that must be used and followed in order to properly carry out this campaign. Takata's documentation is attached and is part of this bulletin.

### IDENTIFICATION NUMBER

Infiniti has assigned identification numbers R1622, R1704, 1706, and R1713 to this campaign. Use Service COMM and the VIN to confirm the correct campaign ID number. The correct number must appear on all communication and documentation of any nature dealing with this campaign.

### DEALER RESPONSIBILITY

It is the retailer's responsibility to check Service COMM or Dealer Business Systems (DBS) National Service History for the campaign status on each vehicle falling within the range of this voluntary safety recall which for any reason enters the service department. This includes vehicles purchased from private parties or presented by transient (tourist) owners and vehicles in a retailer's inventory. **Federal law requires that new vehicles in retailer inventory which are the subject of a safety recall must be corrected prior to sale. Failure to do so can result in civil penalties by the National Highway Traffic Safety Administration.** While federal law applies only to new vehicles, Infiniti strongly encourages retailers to correct any used vehicles in their inventory before they are retailed.

Infiniti Bulletins are intended for use by qualified technicians, not 'do-it-yourselfers'. Qualified technicians are properly trained individuals who have the equipment, tools, safety instruction, and know-how to do a job properly and safely. NOTE: If you believe that a described condition may apply to a particular vehicle, DO NOT assume that it does. See your Infiniti retailer to determine if this applies to your vehicle.

## REPAIR OVERVIEW

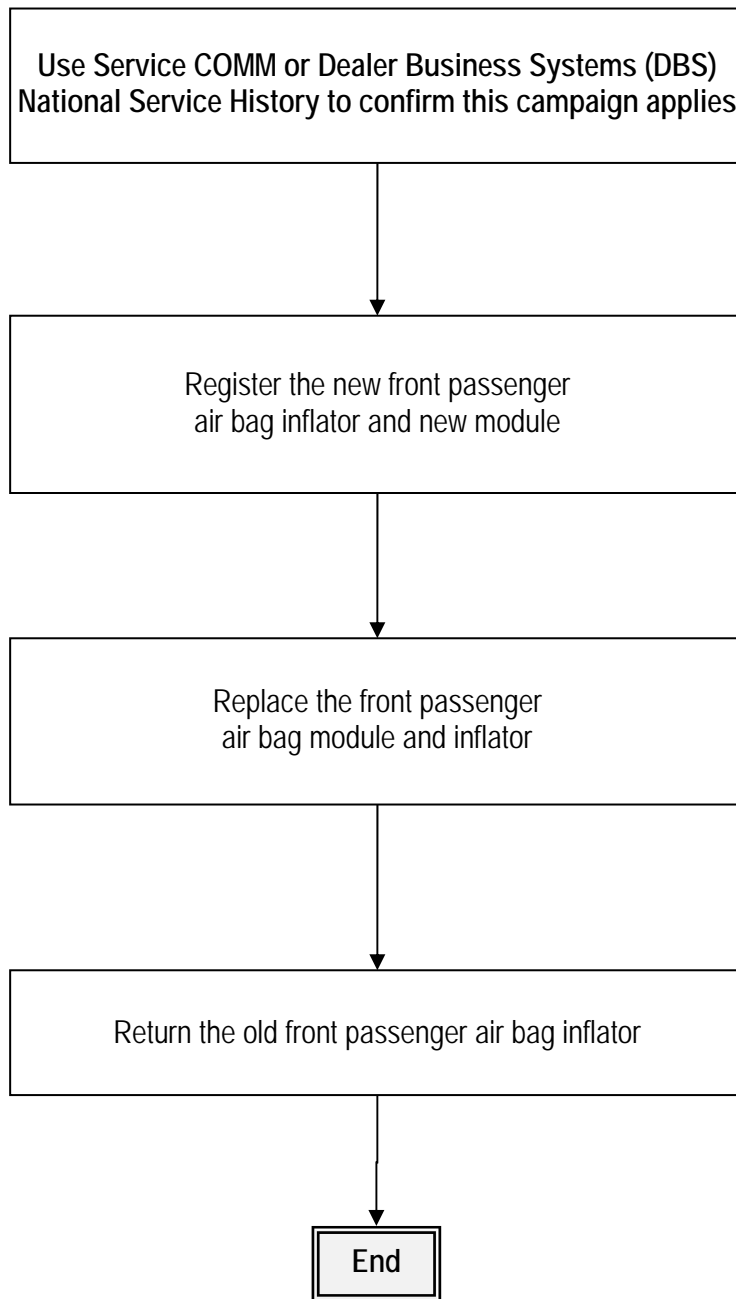

## REQUIRED SPECIAL TOOLS

### Air Bag Module Support (J-51315-KIT)

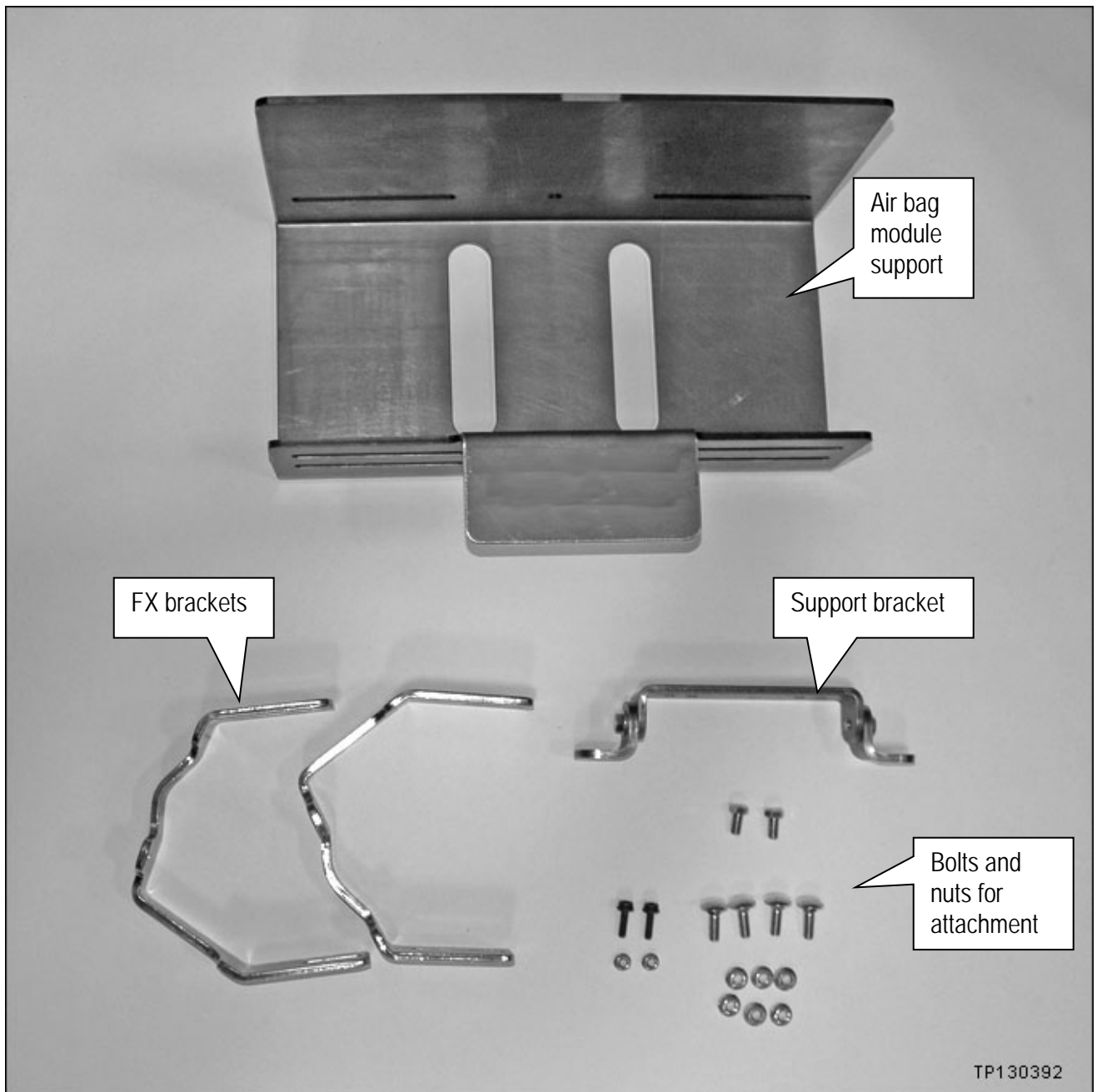

Figure A

## REQUIRED SPECIAL TOOL (J-52352)

### Quick Scan Tool (J-52352)

- Each retailer has been shipped one Quick Scan Tool (J-52352).
- Additional tools can be obtained from Tech•Mate at 1-800-662-2001.



Figure B

## SERVICE PROCEDURE

### New Inflator and New Module Registration

1. Obtain a new inflator and a new module from your parts department.
  - New inflator and new module are listed in the Parts Information.

2. Attach the quick scan tool (J-52352) to your CONSULT PC USB port.



Figure 1

3. On the left side of the ASIST main menu, select Tech Support Info, then Inventory Vehicle Actions.

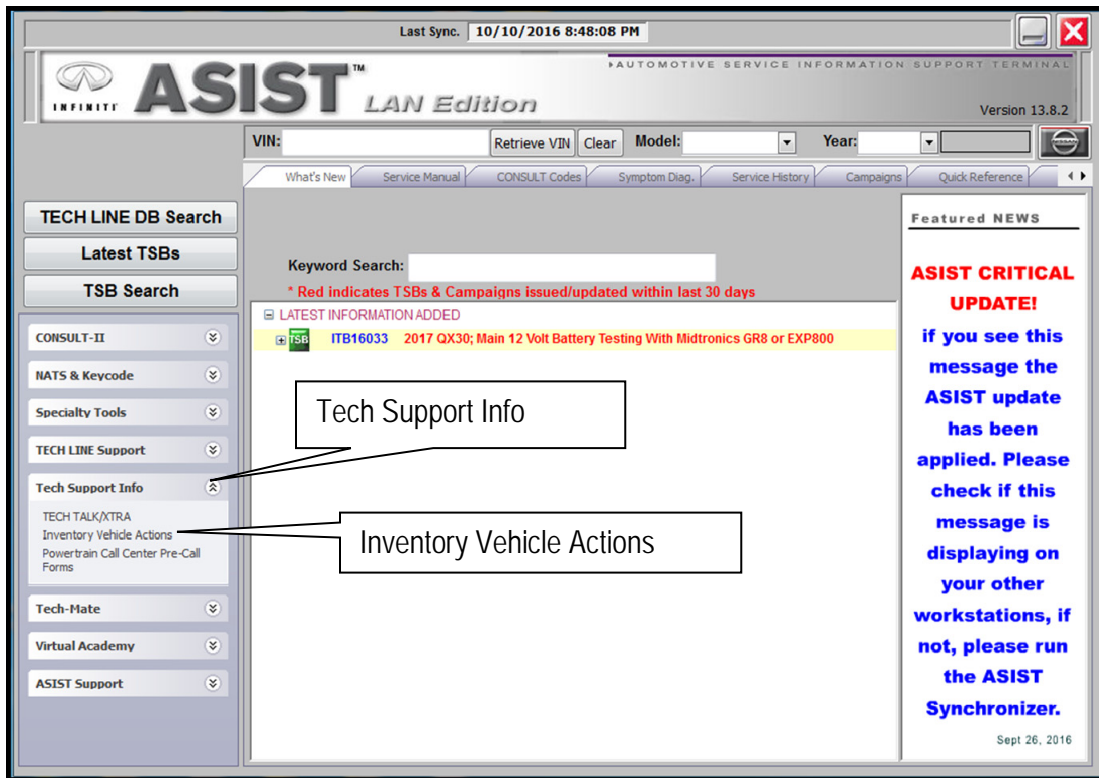

Figure 2

4. Select **CLICK HERE** (Air Bag to VIN Registration).



Figure 3

## Register the New Inflator

5. Use the quick scan tool to scan the bar code (VIN) on the B-pillar label.
  - Wipe any dirt/debris from bar code before scanning.

### NOTE:

- Some labels may not scan quickly.
- Hold the scan tool approximately 6 inches away from the label.
- Hold the trigger down until the label is read (this may take several seconds).
- VIN will automatically populate (see Figure 5).
- If needed, VIN can be entered manually.



Figure 4

**Airbag to VIN Registration**

11/28/2016 1:36:32 PM

**Please enter/scan the VIN and Airbag Inflator Serial Number**

**Dealer Code**      ■■■■

**Key Number**      ■■■

**VIN**     

**Airbag Serial Number**            **Submit**

Step 7; see next page.  
(Select submit after both fields are populated).

Figure 5



**Airbag to VIN Registration**

11/28/2016 1:36:32 PM

**Please enter/scan the VIN and Airbag Inflator Serial Number**

**Dealer Code**

**Key Number**

**VIN**

**Airbag Serial Number**

Step 12; see next page.  
(Select submit after both fields are populated).

Figure 8

9. Open the Module shipping container.
  - New module is listed in the Parts Information.

10. Locate the bar code sticker on the new module.

**NOTE:** The new module will be left in the shipping container until later in this procedure.

11. Use the quick scan tool to scan the bar code (serial number) on the new module (see Figures 9 and 10).

- The serial number will automatically populate (see Figure 8).

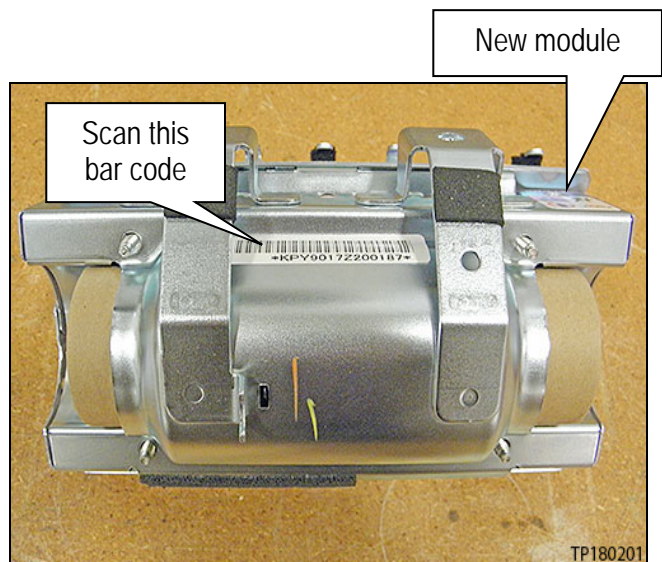

Figure 9

**NOTE:** If needed, the serial number can be entered manually.

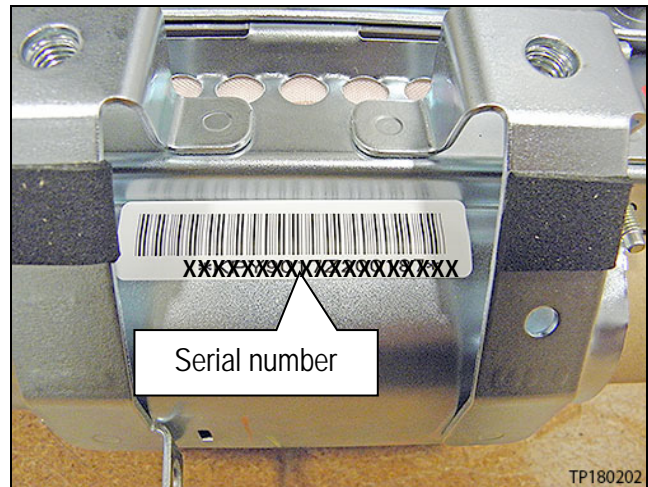

Figure 10

12. Select **Submit** on the ASIST screen (see Figure 8 on the previous page).

### Inflator and Module Replacement

**IMPORTANT:**

- Follow all cautions, warnings, and notes in the Electronic Service Manual (ESM) when working on or near a Supplemental Restraint System (SRS), such as an air bag.

**CAUTION:** Handle interior trim carefully to avoid damage. Work with clean hands and clean tools to avoid dirt and stains. Use protective covers as needed.

13. Turn the ignition ON.

14. Write down the radio settings.

Presets	1	2	3	4	5	6
AM						
FM 1						
FM 2						
SAT 1						
SAT 2						
Bass	Treble		Balance	Fade	Speed Sen. Vol.	

15. Turn the ignition OFF.

16. Disconnect both battery cables, negative cable first.

17. Wait at least 3 minutes.

18. Remove the passenger air bag module (module) from the vehicle.

- Refer to the appropriate ESM for module removal information.

**IMPORTANT:** Follow all cautions, warnings, and notes in the ESM when working on or near the SRS, such as an air bag.

**CAUTION:** Handle interior trim carefully to avoid damage. Work with clean hands and clean tools to avoid dirt and stains. Use protective covers as needed.

19. Set the module in a clean working area.

**NOTE:** Do not set the module with cover facing down.

20. Securely mount the air bag module support (support) in a vice (see Figure 11).

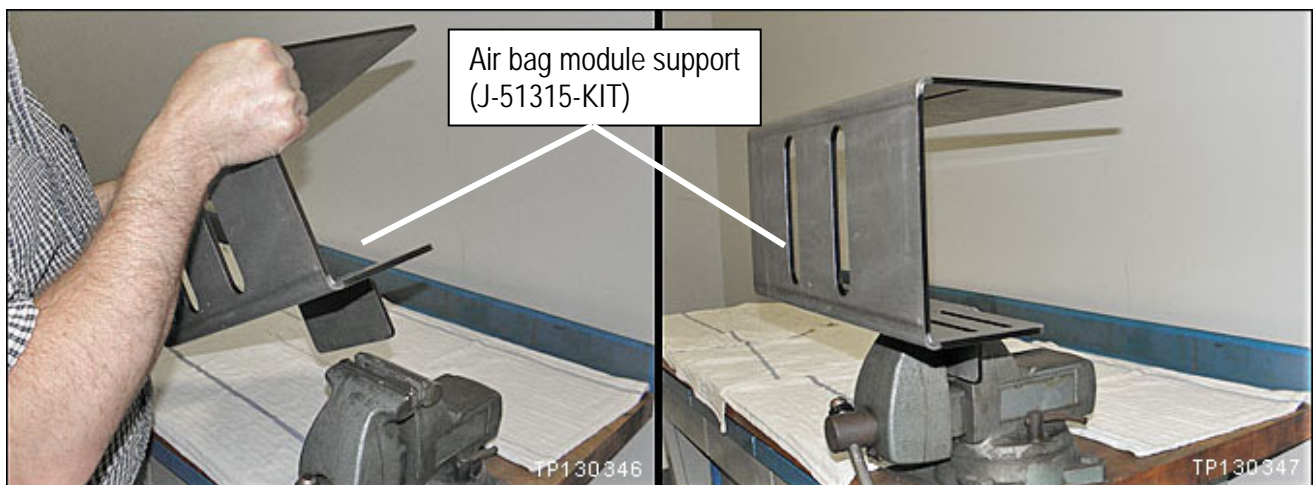

Figure 11

**WARNING:**

- Work from behind and to the sides of the support.
- Wear safety glasses while performing inflator replacement.

21. Disconnect the harness clip from the module frame.

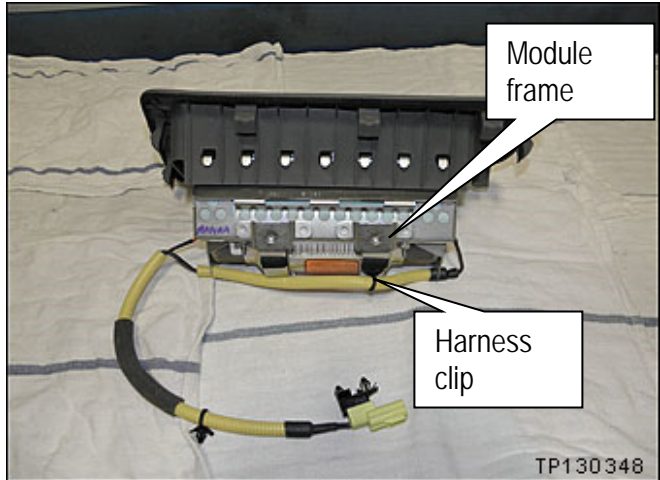

Figure 12

22. Attach the support bracket to the module frame.
- Tighten the bolts holding the bracket to the module frame.
  - Use bolts supplied with the support.
  - Leave the L brackets on each end slightly loose to allow for positioning of the module in the support.

**WARNING:** Work from behind and to the sides of the support.

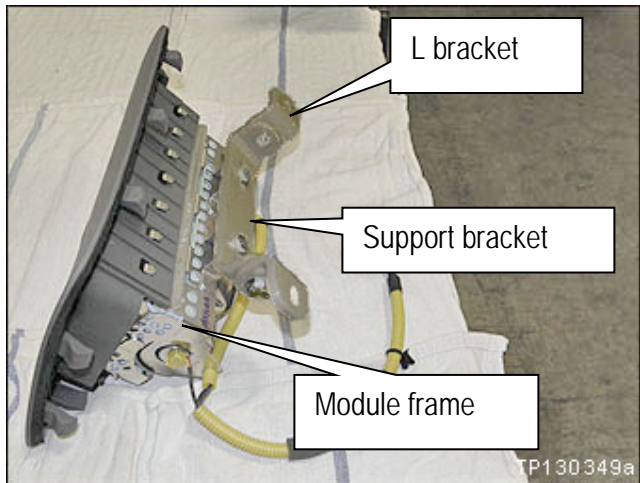

Figure 13

23. Mount the module in the support.
- Use bolts and nuts supplied with the support.
24. Make sure the module is centered in the support.



Figure 14

**NOTE:** Centering the module in the support will allow access to the inflator securing nuts through the slots in the support.

25. Tighten all of the mounting bolts and nuts that hold the module to the support.

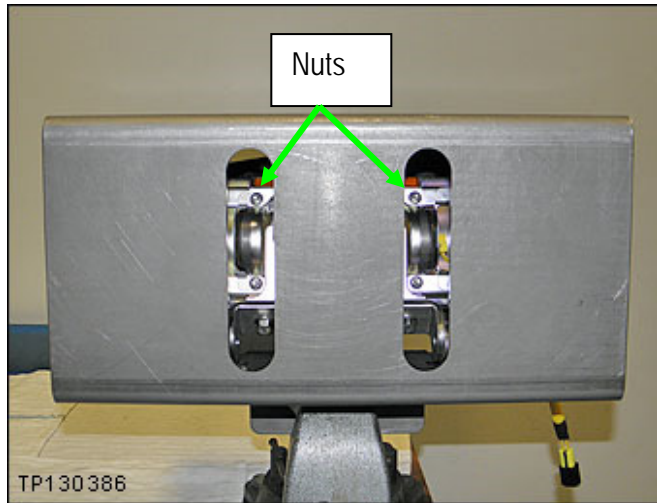

Figure 15

26. Carefully cut a few inches of the yellow corrugated harness cover in the area shown.
  - **Do not** cut the wires inside the corrugated cover.

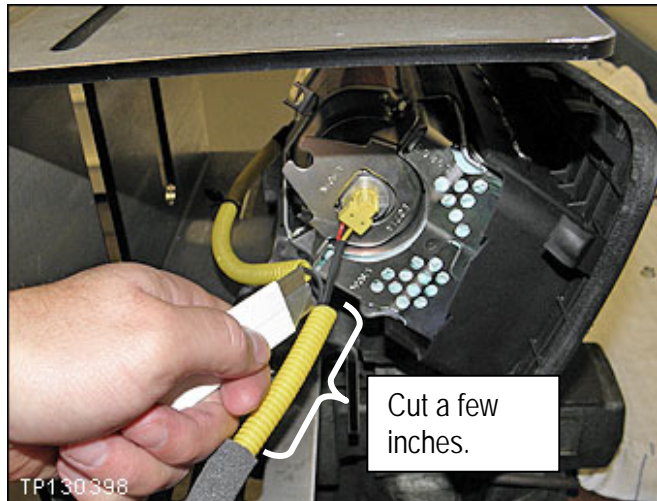

Figure 16

27. Attach 2 shorting pins to the inflator harness as shown.

- Make sure to pair the wires from each end of the inflator.

**Blue with White**

**Red with Yellow**

- Use an insulation displacement type wire connector as a shorting pin.
- Refer to the Parts Information for additional connector/shorting pin information.

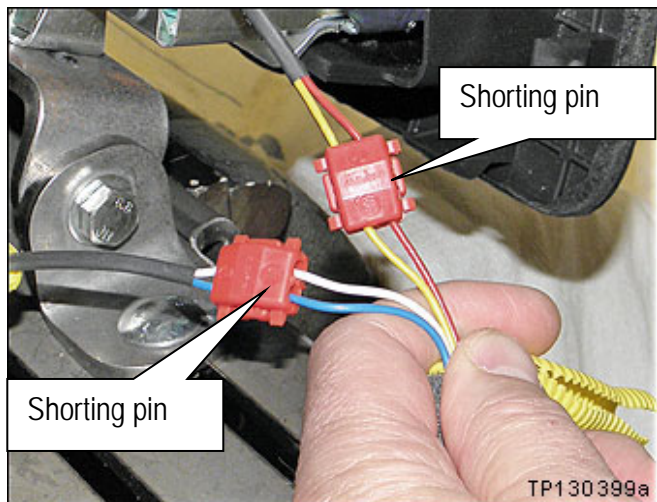

Figure 17

28. Cut off the connector end of the harness.



Figure 18

29. Remove the 4 nuts from the module that hold the inflator in place (see Figures 19 and 20).

- Use a ratchet and extension.



Figure 19

- Remove the 4 nuts.

**NOTE:** These nuts will not be reused.

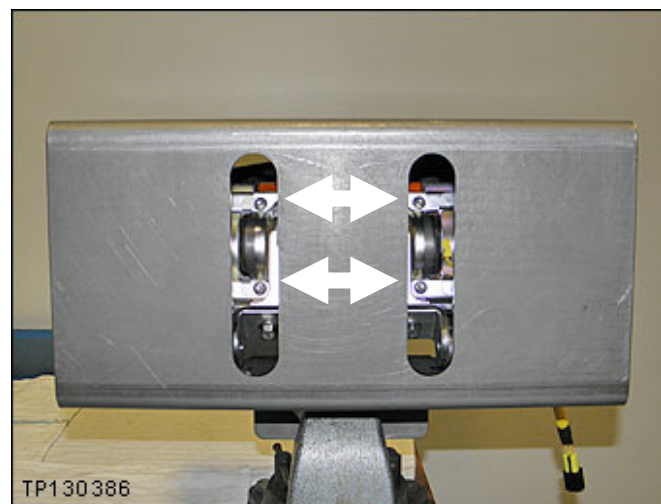

Figure 20

30. Remove the inflator stopper.

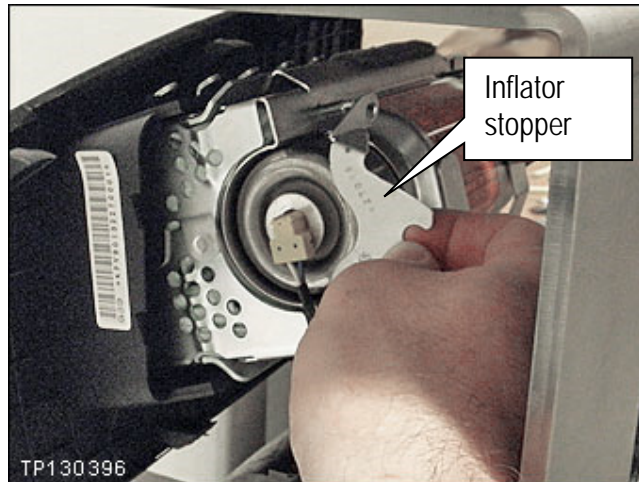

Figure 21

31. Push the right side of the inflator out of the module.

- Twist the inflator to a position that will allow the connector and harness to fit through the opening.

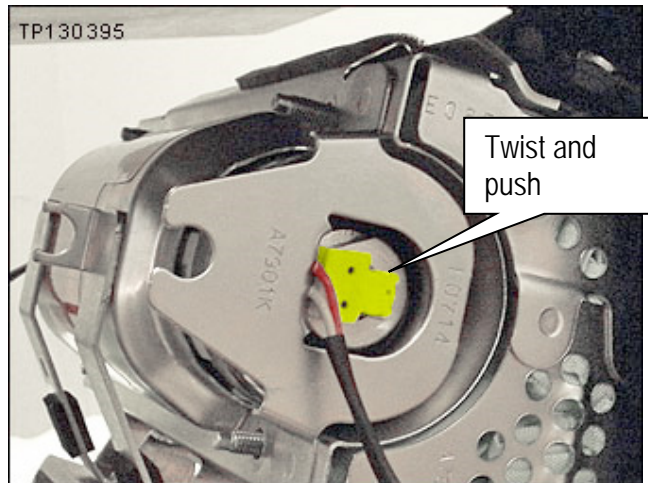

Figure 22

32. Pull the old inflator completely out of the module from the left side.



Figure 23

33. Set the old inflator in the clean working area making sure it does not roll and fall to the floor.

34. Remove the old module from the support and place it on a clean work surface.

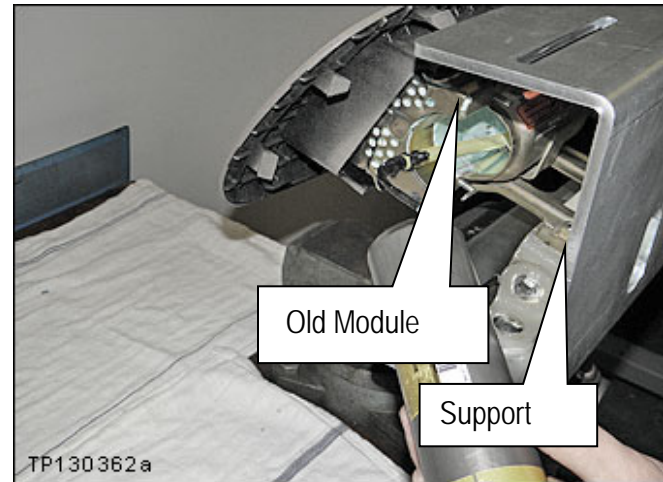

Figure 24

35. Remove the support bracket from the old module.

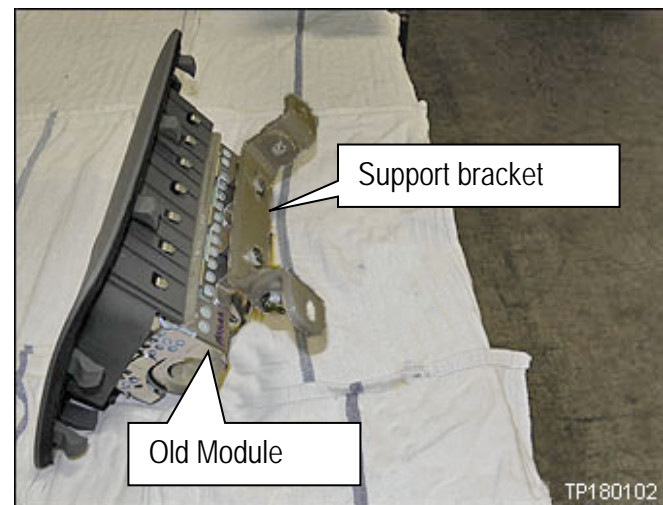

Figure 25

36. Remove the new module from its shipping container.

- New module is listed in the Parts Information.

37. Remove the instrument panel finisher from the old module, and transfer it to the new module as follows.

- a. Set the module on the bench with the mounting holes facing you and longer side of instrument panel finisher on the left.

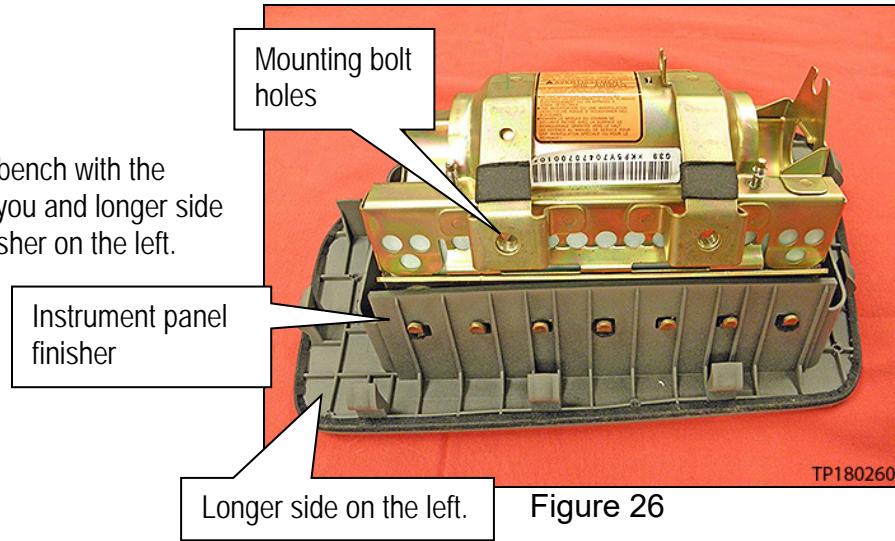

- b. Use a plastic trim tool to detach the module hooks on the side facing you.
- Detach one hook at a time.
  - Start at one end and then work towards the opposite end.
  - Detach all 7 hooks.

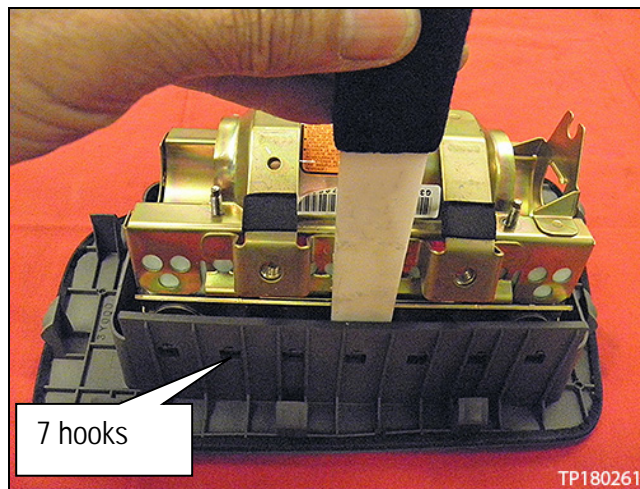

- c. Remove the old module from the finisher.
- Lift out the side facing you.
  - Use a tilt/twist motion to detach the hooks on the other side.

**NOTE:** The old module will not be reused.

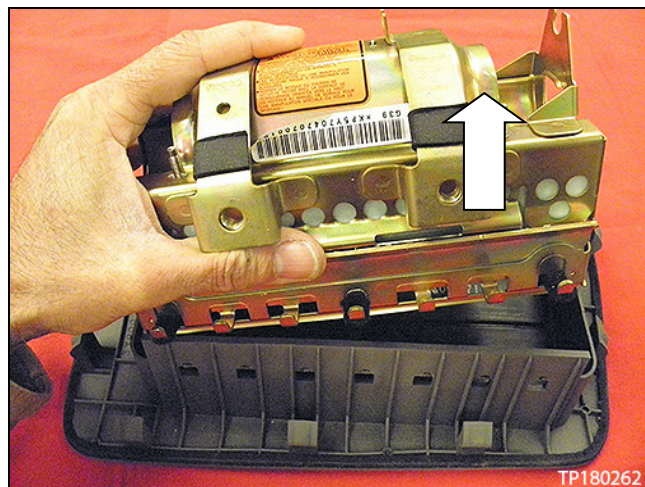

- d. Install the new module to the finisher.
- Make sure the mounting bolts holes are oriented as shown in Figure 29.
  - Make sure all of the hooks are attached correctly.

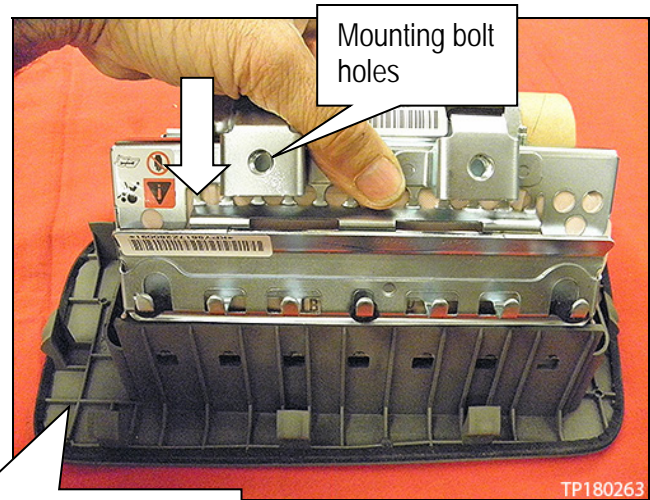

Longer side on the left.

Figure 29

38. Attach the support bracket to the new module frame.

- Use bolts supplied with the support.

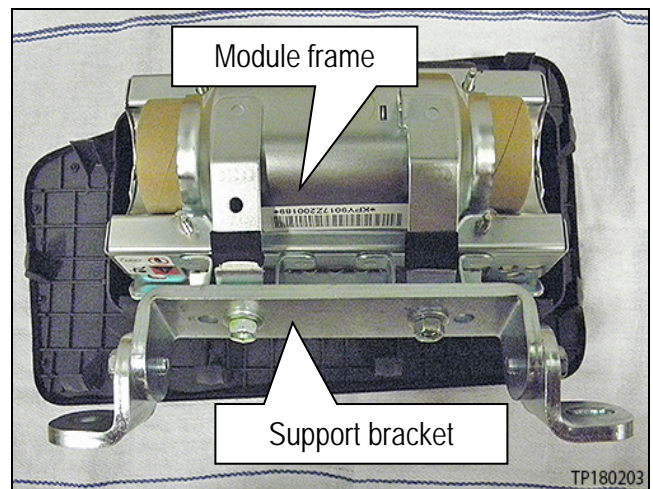

Figure 30

39. Slide the paper tube completely out of the module.

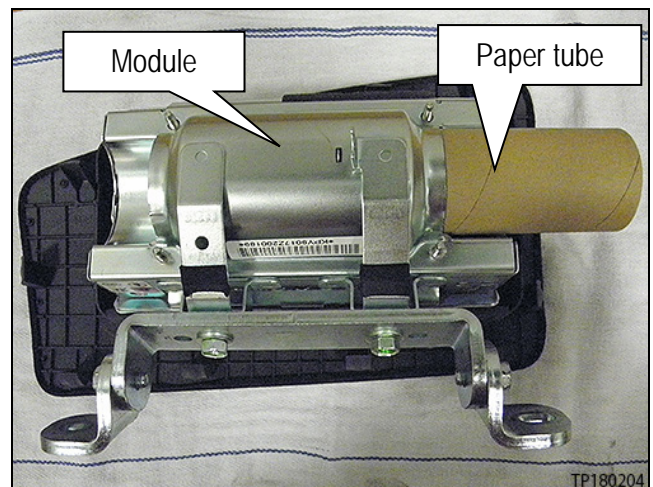

Figure 31

**IMPORTANT:**

- The new module contains two inflator stopper brackets – one for each side.
- In the following steps, make sure to install the correct stopper bracket on each side of the inflator.

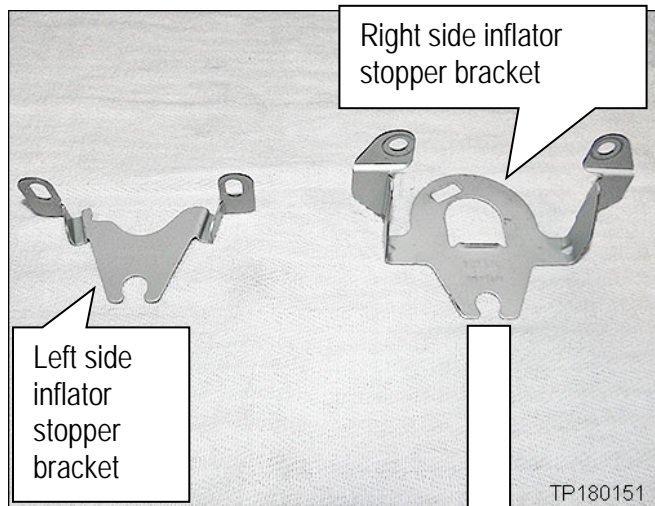

Figure 32

40. Install the **right** side inflator stopper bracket with nuts finger tight (see Figure 33).

- Make sure to **use new nuts**.

**NOTE:** New nuts and new stopper bracket are included with the new module.

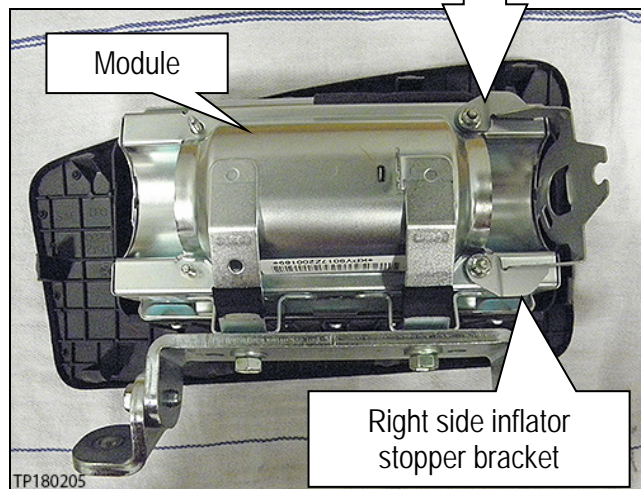

Figure 33

41. Mount the **new** module in the support.

- Use bolts and nuts supplied with the support.

42. Make sure the module is centered in the support.

**NOTE:** Centering the module in the support will allow access to the inflator securing nuts through the slots in the support.

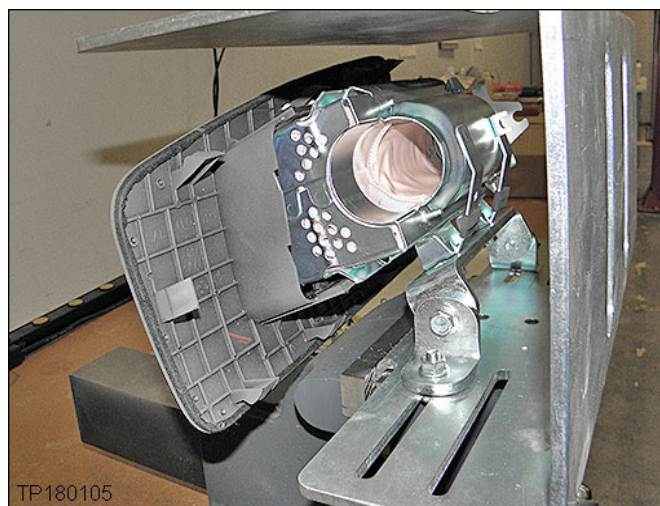

Figure 34

43. Remove the new inflator from the box.

**IMPORTANT:**

- The new inflator has a large plastic end cap and a small plastic end cap.
- When installing, pay close attention to which end is installed first.

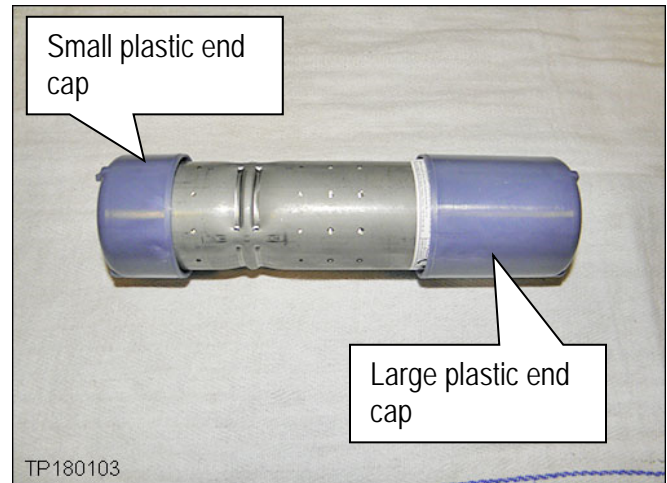

Figure 35

**Install the New Inflator into the New Module**

44. Slide the new inflator into the module assembly from the left side; large plastic end cap first.

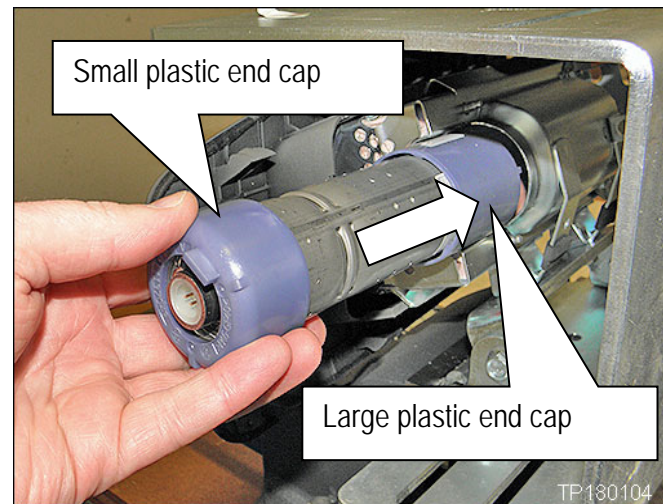

Figure 36

45. On the Right side, make sure the tab on the end of the inflator fits in the stopper bracket as shown.

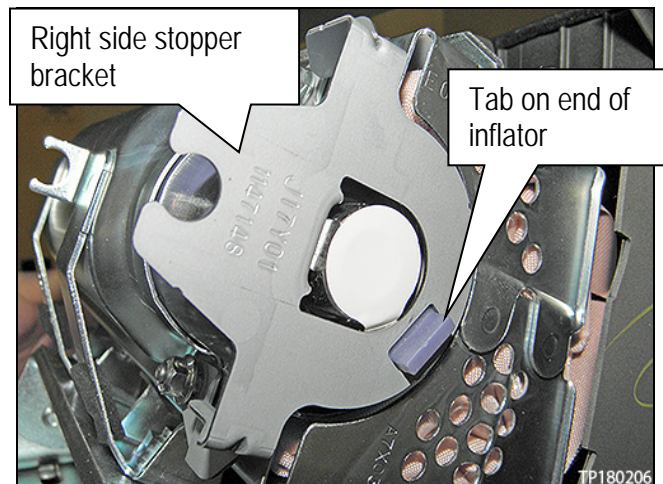

Figure 37

46. Install the **left** side inflator stopper bracket and 2 inflator securing nuts finger tight (see Figure 38).

- Make sure to **use new nuts**.

**NOTE:** Stopper bracket and new nuts are included with the new module.

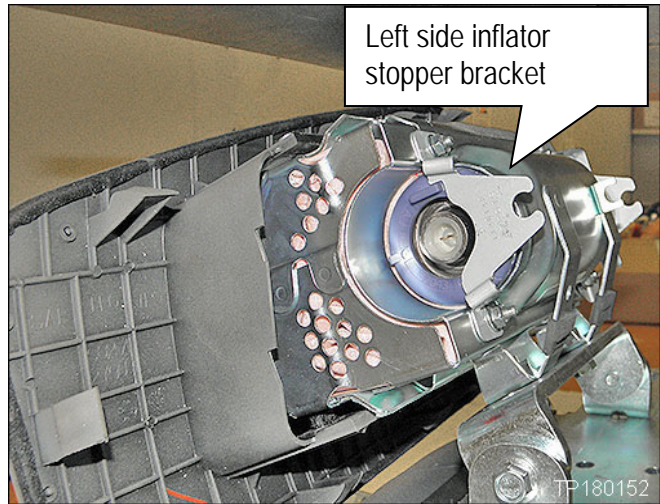

Figure 38

47. Make sure the inflator is pushed all the way into its housing – no gap on the right side (see Figure 39).

48. Make sure there is no gap between the inflator stopper and the inflator on the left side (see Figure 39).

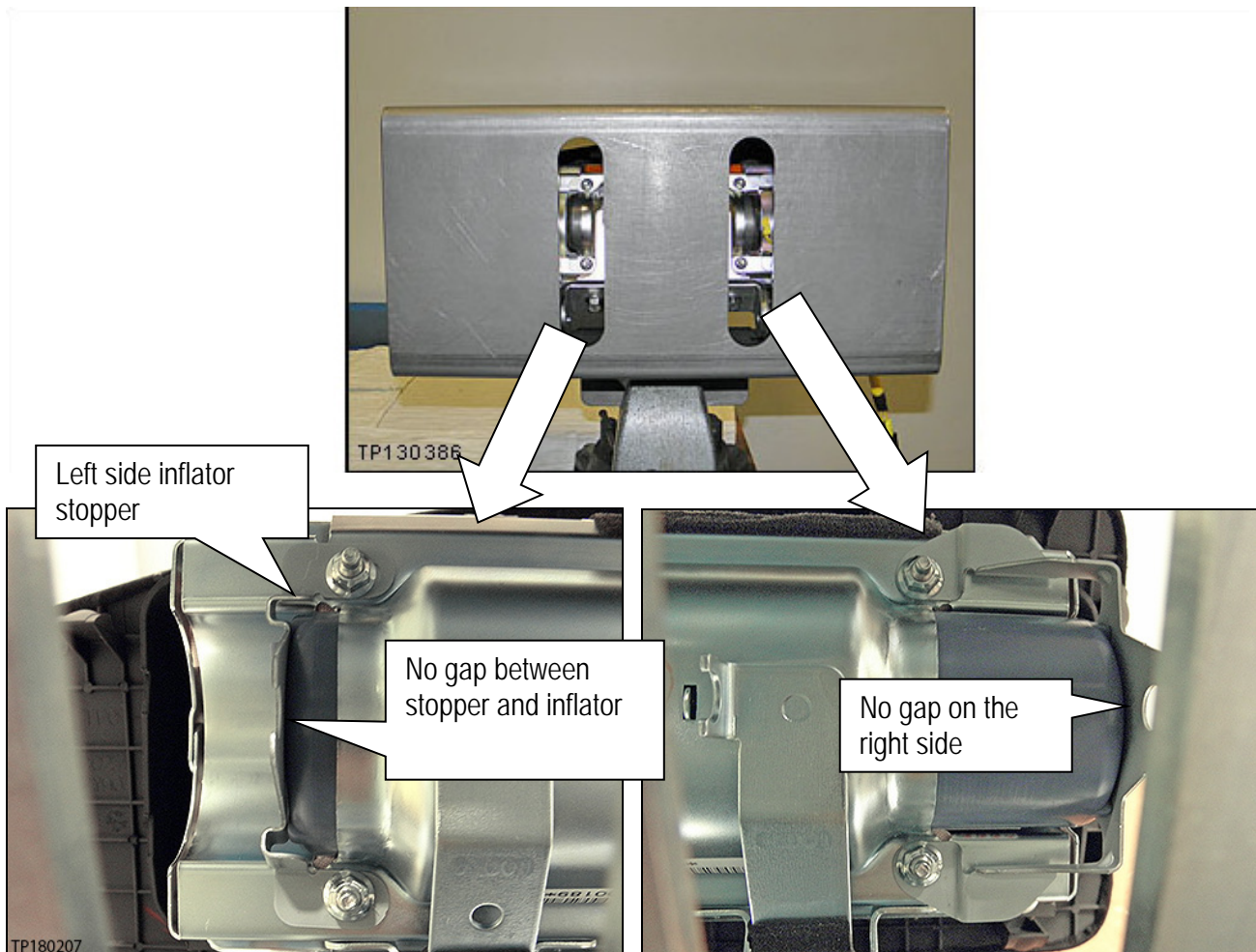

Figure 39

49. Torque the 4 inflator securing nuts.
- Torque nuts to:  
3.9 Nm (0.39 kg-m, 34 in-lb).
  - Torque nuts in the order shown.

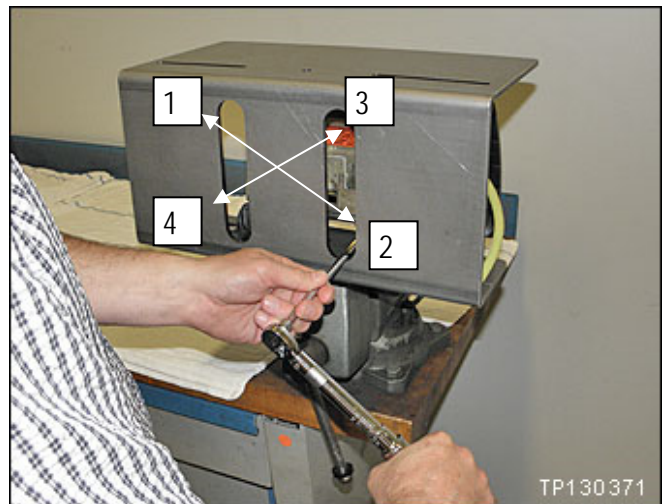

Figure 40

**IMPORTANT:**

- In the next step you will be attaching the new harness to the new inflator.
- Once an inflator connector is attached to the inflator, it cannot be disconnected.
- Make sure to attach the connectors to the correct ends of the inflator (see Figure 41).
  - Left / Right orientation is as shown in Figure 41.

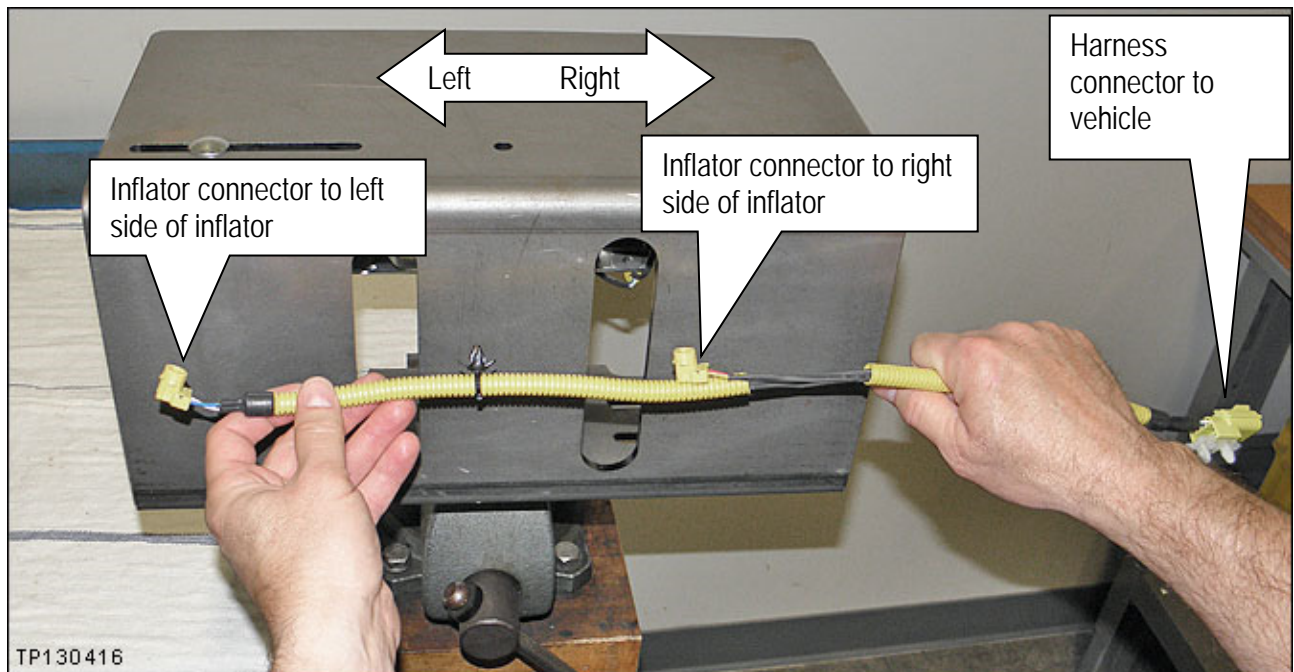

Figure 41

50. Attach the new harness to each end of the inflator.

- Remove the dust proof stickers covering the ends of the inflator.
- A new harness is included with the new module.
- Make sure to attach the correct ends (see Figure 41 on the previous page).
- Refer to Figures 42, 43, and 44.

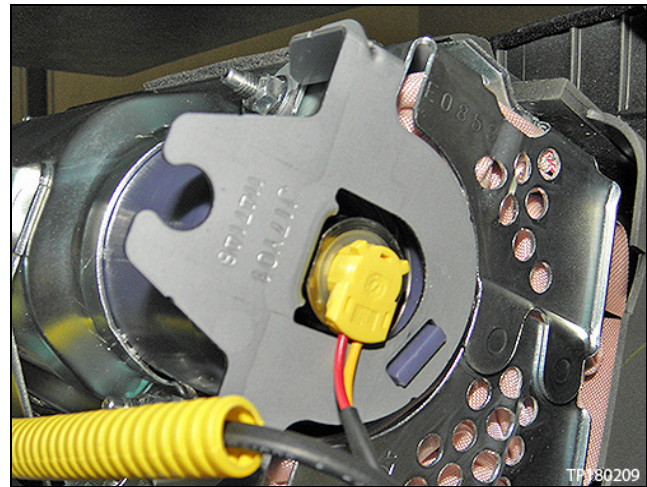

Figure 42

- Make sure the T shape at the inflator end aligns with the T shape of the connector.

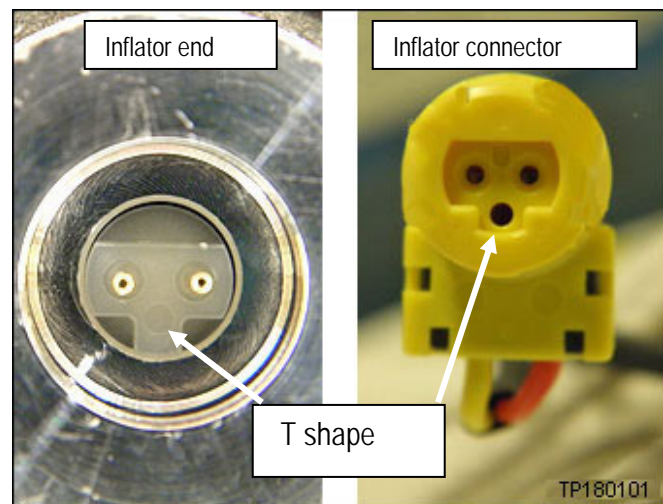

Figure 43

- Make sure the inflator connectors are fully engaged / seated (see Figure 44).

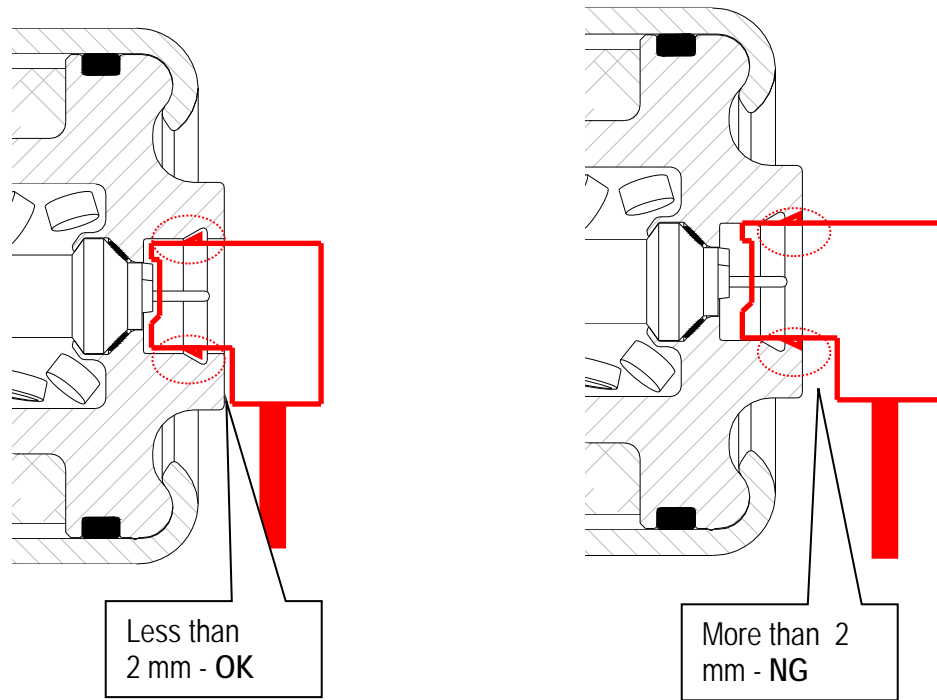

Figure 44

51. Remove the module from the support and set it on the clean working area.

52. Remove the support bracket from the module frame.

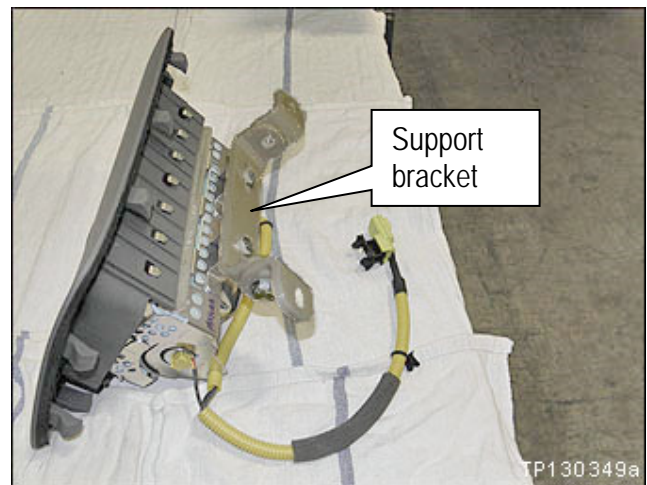

Figure 45

53. Attach the harness clip to the module frame.

54. Route/attach the harness to the harness guides.

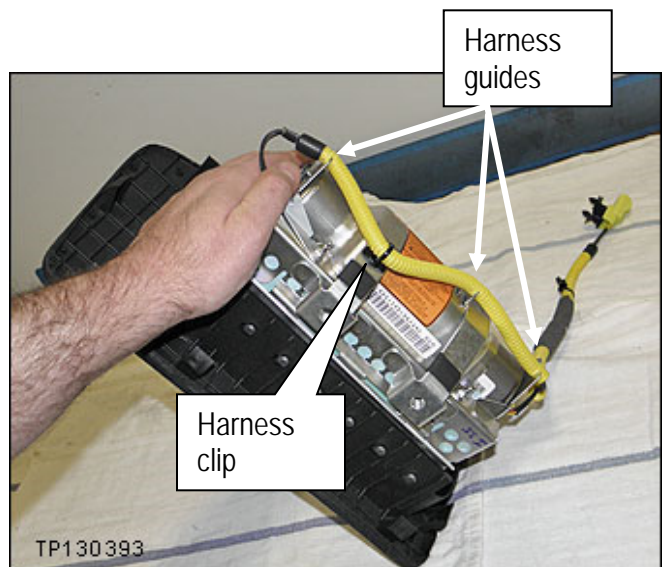

Figure 46

55. Reinstall the module into the vehicle in reverse order of removal.

- Make sure to use the new “one time use” module mounting bolts included with the new module.

56. Re-connect both battery cables – positive cable first.

57. Reset the clock and the radio settings.

58. Turn the ignition ON and observe the air bag warning light:

- Light should illuminate for 7 seconds and then go out.

**NOTE:** If the Air Bag Warning light does not operate as described above there may be an issue not covered by this campaign. Refer to ASIST and the appropriate ESM for additional diagnostic and repair information.

59. Return the removed (old / non-deployed) inflator in the box that the new inflator arrived in.

- Follow the return instructions provided by Takata.
- Return instructions provided by Takata are attached to this bulletin on page 27.

**PARTS INFORMATION**

Description	PART #	Quantity
INFLATOR-AIR BAG ASST (Inflator)	98561-7999E	1
<p>MODULE KIT-SUB (Includes module mounting bolts, inflator harness, inflator securing nuts, and stopper brackets)</p>	K8525-4Y96C	1
<p><b>Shorting Pin</b> (Insulation Displacement Connector for 22-18 gauge wire)</p> 	<p>NAPA item # 784566</p> <p>Grainger Item # 4YT50</p> <p>or equivalent available from local auto supply</p>	2

**NOTE:**

- Make sure to return the removed (old / non-deployed) inflator in the box that the new inflator came in.
- Follow the return instructions provided by Takata.
- Takata supplied return instructions are attached to this bulletin on page 27.

## CLAIMS INFORMATION

**NOTE:** Use Service COMM and the VIN to confirm the correct campaign ID number for a given vehicle. The correct number must appear on all communication and documentation of any nature dealing with this campaign.

Submit a "CM" line claim using the following claims coding:

CAMPAIGN ("CM") I.D.	DESCRIPTION	OP CODE	FRT
R1622	Remove and replace front passenger air bag sub-module and inflator	R1622E	1.0 hrs.

OR

CAMPAIGN ("CM") I.D.	DESCRIPTION	OP CODE	FRT
R1704	Remove and replace front passenger air bag sub-module and inflator	R1704G	1.0 hrs.

OR

CAMPAIGN ("CM") I.D.	DESCRIPTION	OP CODE	FRT
R1706	Remove and replace front passenger air bag sub-module and inflator	R1706A	1.0 hrs.

OR

CAMPAIGN ("CM") I.D.	DESCRIPTION	OP CODE	FRT
R1713	Remove and replace front passenger air bag sub-module and inflator	R17136	1.0 hrs.

## EXPENSE CODE

CODE	DESCRIPTION	MAXIMUM AMOUNT
041	<b>Shorting Pin</b> (Insulation Displacement Connector for 22-18 gauge wire)	\$0.50

# Takata Document

## NOTE

**NOTE: International (including Mexico and Canada), Hawaii, Alaska, Puerto Rico, and US Virgin Islands dealers CANNOT follow below shipping instructions. Instead, dealerships in these locations MUST contact the following Takata/Menlo USA representative directly for shipping instructions: Miguel Prigadaa – Tel #: 210-250-5078 or 210-250-5061 Email: [SCTakataRestraints International@xpo.com](mailto:SCTakataRestraints International@xpo.com)**

**NOTE: For Continental US 48 State dealerships, please follow steps 1-8 below.**

- Specific to Step 4 below:
  - Follow step 4a if you receive the updated NON-FedEx label. Proceed to step 5.
  - Follow step 4b if you receive the FedEx label. Proceed to step 5.

### 1. Shipping Documents

#### a) Box Label

- Supplied with each Kit
- To be affixed to each box



#### b) Over-pack Label

- To be supplied by XPO.
- To be affixed to the outside of each pallet



#### c) Bill of Lading

- To be supplied by XPO.
- Print 2 copies: 1 for Dealer Records, 1 for LTL Driver



#### d) ERG Document

- To be supplied by XPO.
- To be provided by the Dealer to the LTL Driver for each shipment

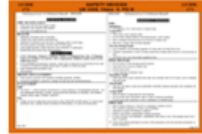

### 5. Shipping Instructions – Prepare the Pallet

- a) Accumulate and palletize Kits
- b) Arrange Kits on Pallet as pictured here
  - 20 boxes per row/layer (5x4)
  - 10 rows/layers per pallet (200 boxes)
- c) Shrink-wrap Kits to Pallet
- d) Affix Over-pack Label on (1) side of Pallet (Not on Top)



### 6. Shipping Instructions – Schedule LTL Pickup

- a) Upon Accumulating 200 kits (1 Over-pack/Pallet) Minimum
  - Call XPO at 1-210-250-5079
  - If 200 Kits have not been accumulated in 30 days, please call XPO for direction
- c) Have the following Information Available
  - Dealer #
  - Quantity of Over-packs/Pallets
  - Quantity of Passenger Inflator Kits on each Pallet
  - Email Address where shipping Documentation can be received

### 2. Packing Instructions

a) Confirm box is in acceptable condition. If a new box is needed, follow the New Box instructions located in Box 8 of this page.

b) Place the un-deployed air bag inflator in the "cradle" of the box insert.



### 3. Closure Instructions

a) Close the top box flap, per box closure instructions located on front panel of box.



### 7. Shipping Instructions – Ship

- a) Give 1 Copy of BOL and 1 Copy of ERG to Driver
- b) Retain 1 Copy of BOL for Dealership records and archive for 2 Years

### 8. Requesting a New Box / Shipping Labels

If a new box or replacement shipping labels are needed, please contact the representative listed below by phone or email to request replacement materials.

Primary Contact: **Armando Gonzalez - Tel #: 210-250-5079**  
E-Mail: [SCFieldaction.14305@xpo.com](mailto:SCFieldaction.14305@xpo.com)

To help expedite your request, please be prepared to provide the following information:

a) Serial number on the original box



b) What Type of shipping material needed

- Replacement Box
- Two Part Return Label
- Bill of Lading
- ERG Form

c) Dealer Shipping Information

- Contact name
- Dealer Address
- Phone Number

### 4a. Shipping Instructions - Label each Box

a) New Labels will begin shipping in each kit starting mid June, 2015

1. Nissan Inflator Kit will contain this two-part label:
2. Peel off "Ship To" Label.
3. Affix Label to Box. Do not cover up Class 9 Marking.