



SAFETY RECALL BULLETIN

NHTSA RECALL 16V-319, Transport Canada 2016-235

AUTOCAR INDUSTRIES, LLC SAFETY RECALL MDTT-1601

June, 2016

Attention:

Service Managers/Parts Managers

Subject:

Autocar has determined that a safety defect could exist in the wheel ends of certain 2016-2017 model year Xspotter trucks and 2017 model year Xpert trucks. The tab lock washers on the rear axle wheel ends may not have been properly bent over the outer spindle nut during assembly.

Safety Recall Information:

This document contains information regarding the inspection and correction of the tab lock washer issue.

Vehicles Affected:

There are 43 affected vehicles assembled after March 4, 2016. Refer to the VIN list on Page 6.

Service Responsibility:

Service sites must perform this recall on affected vehicles at no charge to the owner regardless of vehicle mileage, age or ownership. If a vehicle affected by this recall is taken into or is currently in your vehicle inventory, or at your center for service, you must perform this recall before the vehicle is sold or released to the owner.

Required Parts:

(4) 3973009-006 Axle Shaft Gasket

Note: *Single rear axle trucks will only require 2 of the 4 gaskets.*

To Obtain Parts:

Ensure that you have authorization from the customer to perform this work, and send an e-mail to warranty@autocartruck.com and include the following:

- VIN(s) (or last 6 digits of VIN(s))
- 'Attention To' name
- 'Ship To' address

Claims for Reimbursement:

Submit a claim for reimbursement in accordance with Autocar's Warranty Administration Manual.

Claim Coding Information

(Xpert):

Labor Operation Code Number	Time Allowance SRT	Description
77313-0-04	.50 HR per wheel end	Tab Lock Washer Verification

Claim Coding Information

(Xspotter):

Labor Operation Code Number	Time Allowance SRT	Description
3.11.1	.50 HR per wheel end	Tab Lock Washer Verification



SAFETY RECALL BULLETIN

NHTSA RECALL 16V-319, Transport Canada 2016-235

AUTOCAR INDUSTRIES, LLC SAFETY RECALL MDTT-1601

June, 2016

Tools Required:

- Jack Stand
- Drain pan
- 4" Axle nut socket
- Dial indicator
- Torque wrench capable of 250 ft-lb
- Heel bar

Safety Notices



WARNING

To prevent eye injury, always wear eye protection when performing vehicle maintenance, service or inspection.



WARNING

Before working on a vehicle, set the parking brake, place the transmission in neutral and block the wheels. Failure to do so can result in unexpected vehicle movement and can cause serious personal injury or death.



WARNING

Autocar natural gas powered vehicles require specific compliance in the service, storage and refueling procedures.

If you store or dispense Compressed Natural Gas (CNG) or Liquid Natural Gas (LNG), or if you work on CNG or LNG trucks, your location must be fully compliant with applicable codes, regulations and standards, including National Fire Protection Association (NFPA) codes, Society of Automotive Engineers (SAE) standards, American National Standards Institute (ANSI), Natural Gas Vehicle (NGV) standards, the United States Code of Federal Regulations (CFR), and your state and local fire and other applicable codes (including the California Code of Regulations and the Texas Administrative Code, as applicable).

Contact your local fire department for guidance and additional compliance information. Technicians working on Autocar trucks with CNG or LNG engines must be trained in the proper repair of CNG and LNG engines and the safe storage and dispensing of CNG and LNG.



SAFETY RECALL BULLETIN

NHTSA RECALL 16V-319, Transport Canada 2016-235

AUTOCAR INDUSTRIES, LLC SAFETY RECALL MDTT-1601

June, 2016



CAUTION

LOCKOUT/TAGOUT PROCEDURES

Before entering the vehicle or vehicle body, read and follow OSHA regulations concerning entry and working in “CONFINED SPACE” OSHA 1910.146 and “LOCKOUT/TAGOUT” OSHA 1910.147. Follow OSHA regulations while performing any work on the vehicle. The vehicle must be disabled by the following steps before performing any work on the vehicle:

1. Place the transmission in NEUTRAL.
2. Set the parking brake.
3. Shut the engine OFF.
4. Lock cab doors, keep the key in your pocket. Block the wheels before entering the body or performing any work on the vehicle.
5. Turn the battery disconnect switch OFF, if equipped.
6. Completely drain the air from the primary/A system and secondary/B system by opening the drain valves on the air tanks themselves or by using the drain manifold if supplied. When draining the air tanks, do not look into the area where air is draining. Dirt or sludge particles may be expelled in the air stream and can cause eye injury.
7. Place magnetic “DANGER” signs on both cab doors before entering the body or performing any work on the vehicle.
8. Take proper precautions before working under the vehicle. Use ramps approved for the weight of your vehicle, or use floor jacks and stands. Never work under a vehicle supported by jacks alone. Always use jack stands to support the vehicle.

SAFETY RECALL BULLETIN

NHTSA RECALL 16V-319, Transport Canada 2016-235

AUTOCAR INDUSTRIES, LLC SAFETY RECALL MDTT-1601

June, 2016

Inspection and Repair Instructions

Note: For each drive axle wheel end, perform the following inspection and or correction.

1. Remove the axle flange nuts, washers and axle and set aside for reinstallation (see Figure 1).
2. Remove the axle shaft gasket and discard (see Figure 1).
3. Inspect the tab lock washer to ensure that the tabs are properly bent over the outer spindle nut (tabs bent 180 degrees across from each other) (see Detail A).

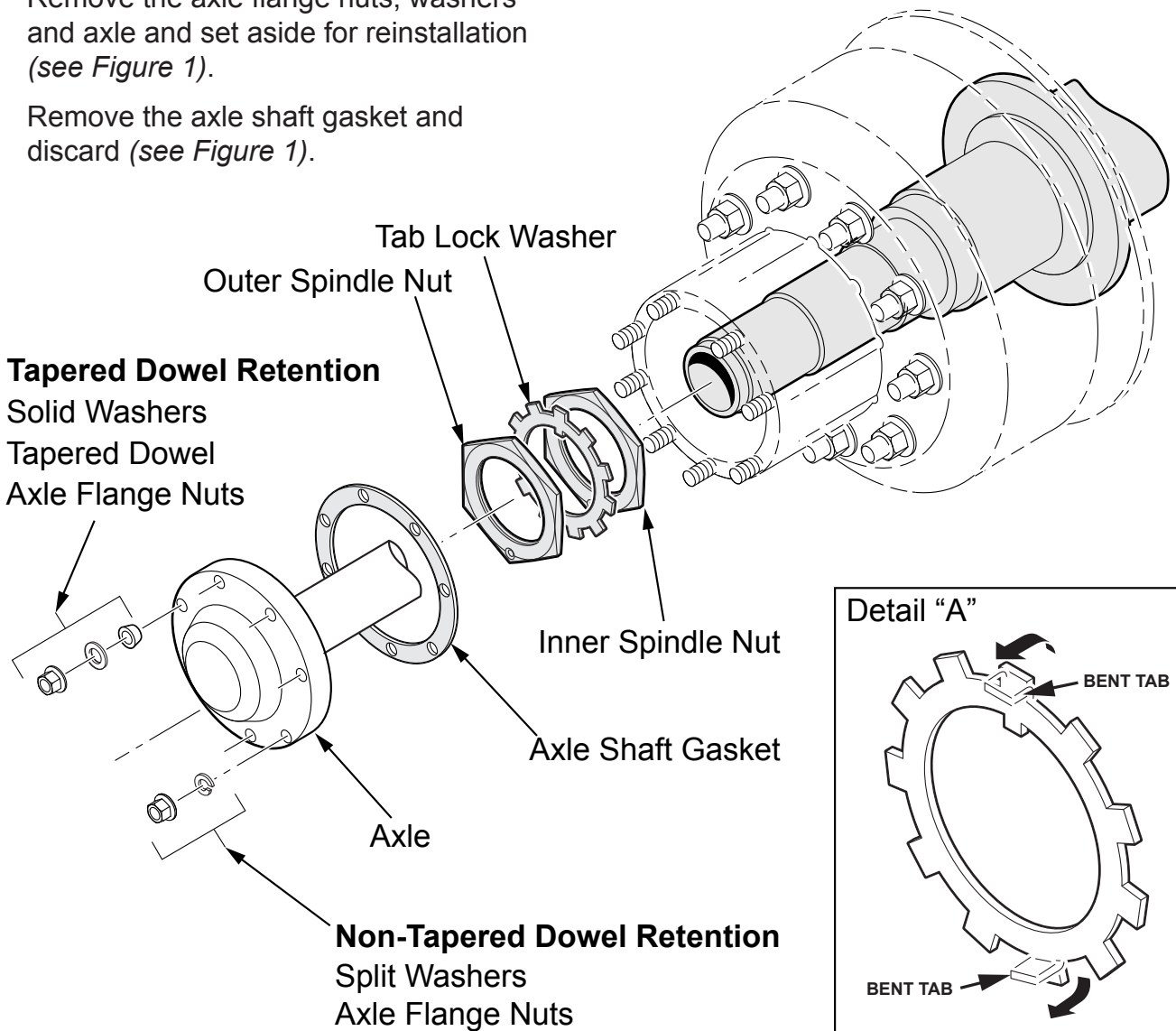

Figure 1

SAFETY RECALL BULLETIN

NHTSA RECALL 16V-319, Transport Canada 2016-235

AUTOCAR INDUSTRIES, LLC SAFETY RECALL MDTT-1601

June, 2016

Note: If the tab lock washer **is not** properly bent over the outer spindle nut, proceed to step 4. If the tab lock washer **is** properly bent over the outer spindle nut, proceed to step 11.

4. Raise the wheel end and support with an appropriate jack stand.
5. Release the park brake.
6. Remove the outer spindle nut and tab lock washer and set aside for reinstallation (see Figure 1).
7. Tighten the inner spindle nut to 200 ft-lb of torque (see Figure 1).
8. Using a counterclockwise motion, back off the inner spindle nut one turn.
9. While rotating the wheel end assembly, tighten the inner spindle nut to 50 ft-lb of torque.
10. Using a counterclockwise motion, back off the inner spindle nut 1/6 (one flat) turn.
11. Reinstall the tab lock washer that was set aside in step 6.
12. Reinstall the outer spindle nut that was set aside in step 6 and tighten to 250 ft-lb of torque.

13. Using a dial indicator on the outer spindle nut, check the wheel end run out to verify wheel end play is between .001" and .005".

Note: After this step If the wheel end play is not within the specified range, repeat steps 6 through 10, adjusting the back off amount until the end play is within the specified range.

14. Bend two tabs on the tab lock washer outward 180 degrees across from each other over the outer spindle nut (see Detail A).
15. Clean the hub and axle flange of all residual gasket material.
16. Install the new axle shaft gasket (3973009-006) (see Figure 1).
17. Reinstall the axle and secure with the axle flange nuts and washers that were set aside in step 1.
18. Tighten the axle flange nuts to 190 ft-lb of torque if equipped with non-tapered dowel retention or 85-115 ft-lb of torque if equipped with tapered dowel retention (see Figure 1).
19. Set the park brake and lower the wheel end.
20. Repairs are completed.