

ATTENTION:

- GENERAL MANAGER
- PARTS MANAGER
- CLAIMS PERSONNEL
- SERVICE MANAGER

IMPORTANT - All Service Personnel Should Read and Initial in the boxes provided, right.



QUALITY DRIVEN® SERVICE

© 2016 Subaru of America, Inc. All rights reserved.

REPAIR PROCEDURE

APPLICABILITY: 2016-2017 MY Legacy and Outback
SUBJECT: Inspection and Repair Procedure for Stop Sale / Recall Campaign
 WTD-65: Steering Column

NUMBER: WTD-65
DATE: 05/10/16

IMPORTANT: For more information, refer to Subarunet message dated 5/9/2016 regarding the WTD-65 Stop Sale Notice. A complete Product Campaign Bulletin will be released shortly. This bulletin is to inform Subaru retailers of the inspection and repair procedures only.

This Service Procedure provides an inspection method for identification of affected vehicles and if determined necessary, additional steps for replacing the steering column assembly.

INSPECTION PROCEDURE:

- Confirm the vehicle is within the provided VIN range.
- Locate the lot number label at the base of the steering column located just above the toe board grommet as shown in the photo below.



- Decode the lot number of the steering column using the illustration below.
- If the lot number on the steering column label is within the range between 6228 (February 28, 2016) and 6416 (April 16, 2016), the steering column assembly must be replaced.
- If the lot number is illegible or otherwise cannot be determined, it must be noted on the repair order and the steering column assembly must be replaced.

Continued...

CAUTION: VEHICLE SERVICING PERFORMED BY UNTRAINED PERSONS COULD RESULT IN SERIOUS INJURY TO THOSE PERSONS OR TO OTHERS.

Subaru Service Bulletins are intended for use by professional technicians ONLY. They are written to inform those technicians of conditions that may occur in some vehicles, or to provide information that could assist in the proper servicing of the vehicle. Properly trained technicians have the equipment, tools, safety instructions, and know-how to do the job correctly and safely. If a condition is described, DO NOT assume that this Service Bulletin applies to your vehicle, or that your vehicle will have that condition.

SUBARU OF AMERICA, INC. IS ISO 14001 COMPLIANT

ISO 14001 is the international standard for excellence in Environmental Management Systems. Please recycle or dispose of automotive products in a manner that is friendly to our environment and in accordance with all local, state and federal laws and regulations.

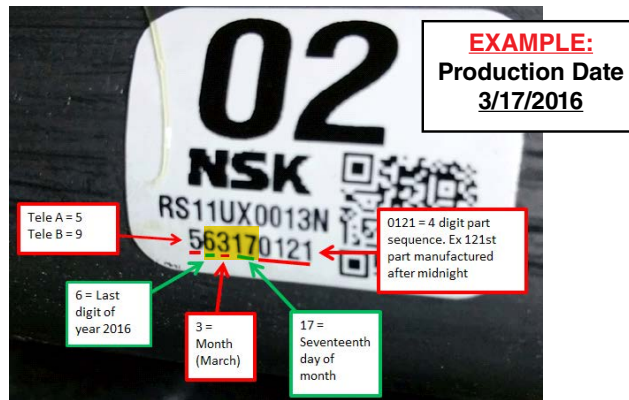

- **IMPORTANT:** Always record the lot number on the Repair Order even if it is outside the affected range.

PARTS INFORMATION:

Description	Part Number	Applicability
COLUMN ASSEMBLY	34500AL02A	Key Start
	34500AL03A	Push-Button Start
BOLT (shear)*	83140GA000	All

* One new shear bolt is **included** with the replacement steering column.

SERVICE PROCEDURE:

After performing the Inspection procedure, if determined necessary, replace the steering column assembly following the Service Procedure provided below.

CAUTION: Refer to the “CAUTION” Section in the General Description portion of Airbag System AB in the Body Section of the applicable Service Manual before handling any airbag module!

- Before proceeding with disassembly, unlock the tilt lever (1), adjust the tilt position of the steering column to the neutral position (2), adjust the telescopic position to the longest position (3) and place the lock lever back into the “locked” position (4).

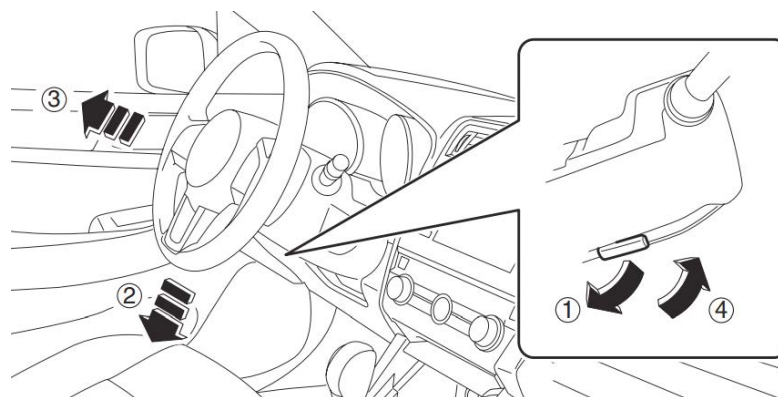

- Record the customer’s radio station presets (and Navigation Favorites where applicable).
- Confirm the status of STARLINK Telematics lamp (where applicable). If the Green LED is on, press the RED SOS button to confirm an operator answers.
- Disconnect the negative battery cable from the battery sensor and wait at least 60 seconds before proceeding.

Continued...

- Using a plastic trim tool, remove the instrument panel end cover.



- Remove the data link connector, release the 3 retaining clips and remove the lower the instrument panel under cover.

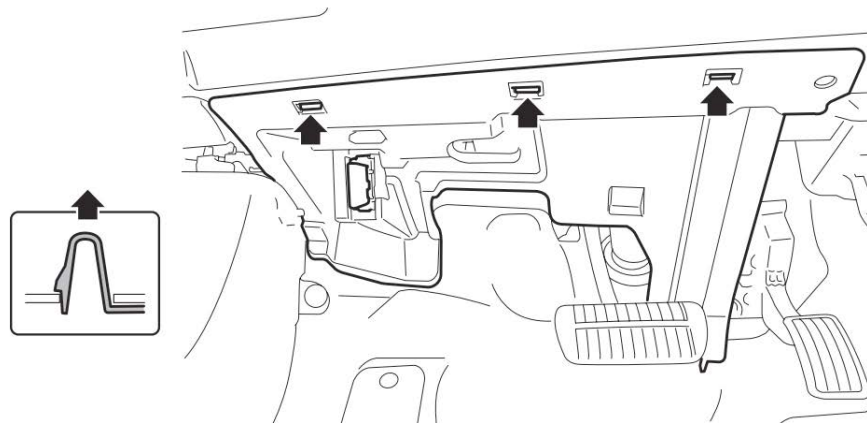

- Remove the necessary screws, release the claws and disconnect the harness connectors from the switches before **CAREFULLY** removing the instrument panel lower trim cover.
NOTE: When removing the cover, pull it straight back toward you as shown in the illustration below. Do not pull / turn it upward as doing so may damage the retaining claws.

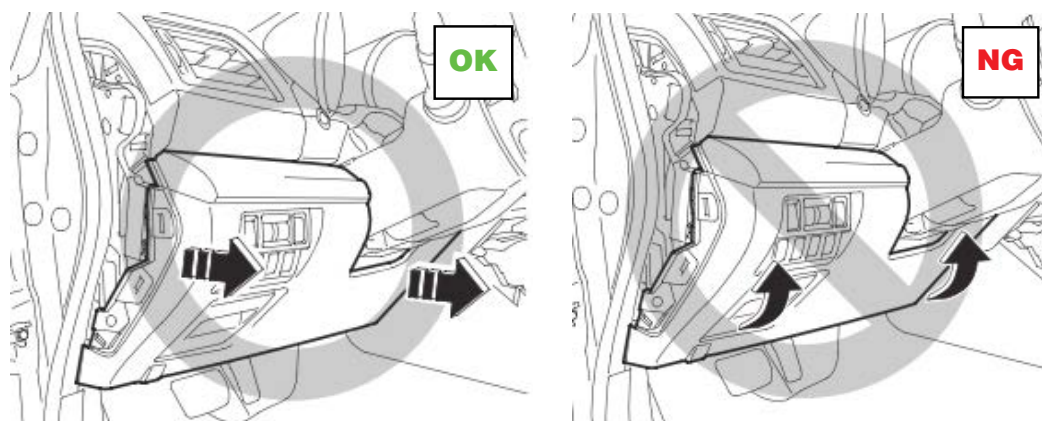

Continued...

- Remove the knee guard.

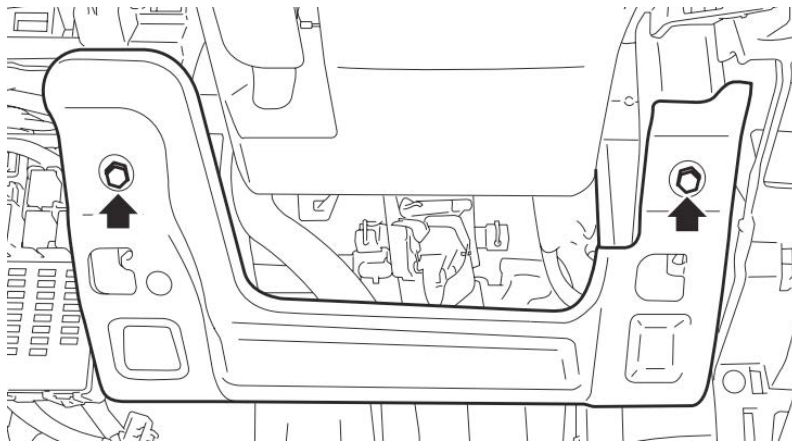

- With the wheels pointed straight ahead and using a hexagon wrench (or equivalent) wrapped with protective tape, locate and press on the snap pins to release the locks (three locations) securing the driver's airbag module.

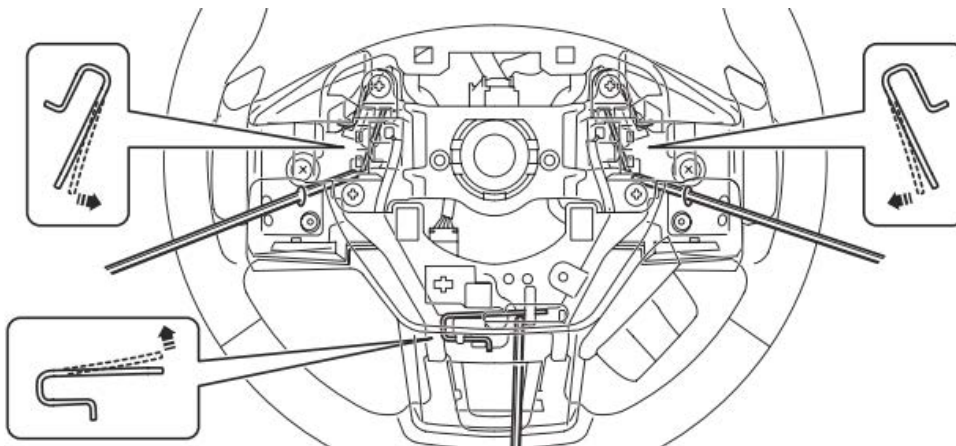

- **CAREFULLY**, release / remove the 2 airbag module harness connectors and set the module aside in a safe place.

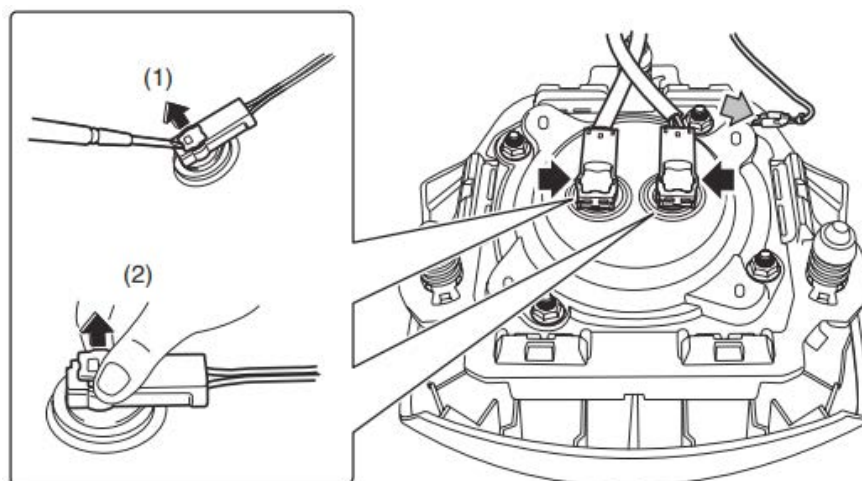

- Using a steering wheel puller to prevent deforming the steering wheel, remove the steering wheel.

Continued...

- Using a plastic trim tool, **CAREFULLY** release the retaining claws and remove the upper and lower steering column trim covers.

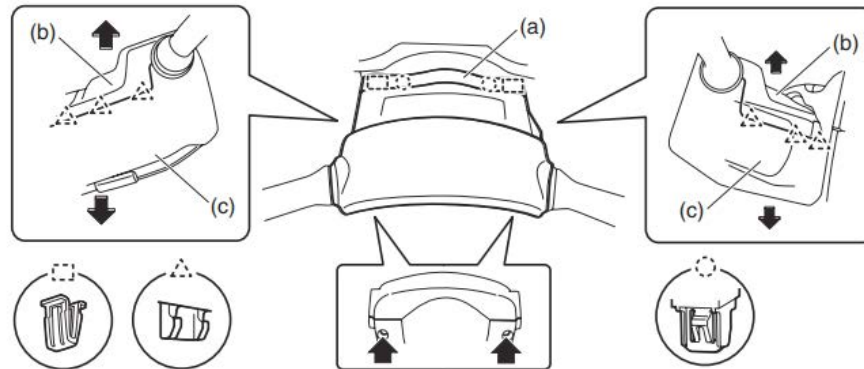

- After disconnecting all the wiring harness connectors, **CAREFULLY** remove the roll connector, steering angle sensor and the combination switch assemblies. **IMPORTANT:** Do not disturb the position of the roll connector while removed from the steering column. If the roll connector position is changed, the center position adjustment procedure shown below must be performed before reassembly.

CAUTION: Do not rotate the roll connector to more than the specified number of turns. Otherwise, the roll connector internal wire may be broken. When determining the end stop, rotate the connector slowly without applying excessive force. Applying excessive force at the end stop may also break the internal wire.

- 1) Confirm the front wheels are positioned in straight ahead direction.
- 2) Rotate the roll connector counter-clockwise until it stops.
- 3) Rotate the roll connector clockwise approximately 2.5 turns until the “Δ” marks are aligned.

NOTE: When the roll connector comes to the center position, the orange roller (b) can be seen from the sight glass (a) as shown below.

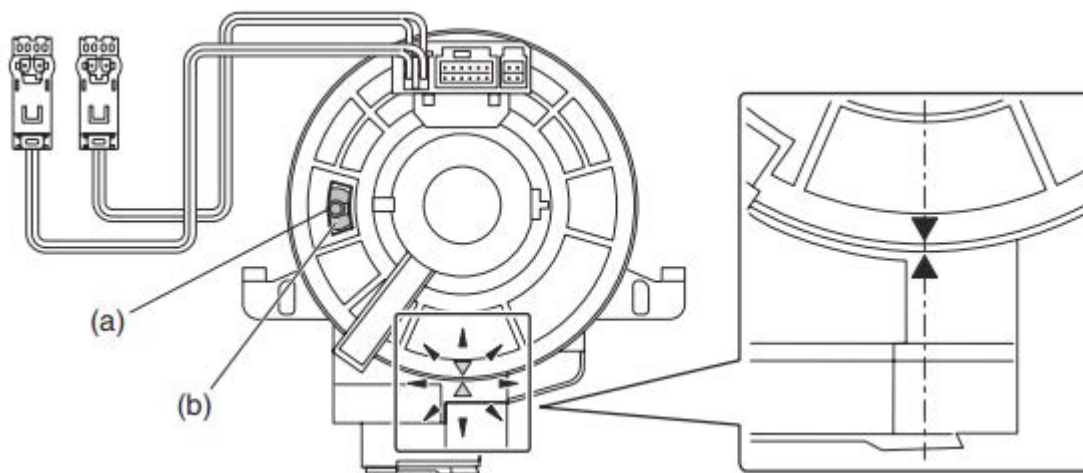

- Remove the engine under cover assembly.
- On H-6 models, remove the front exhaust pipe assembly.

Continued...

- Place an alignment mark on the lower universal joint shaft and steering rack input shaft.
- Remove the 2 retaining bolts and universal joint shaft assembly.
- Remove the 2 bolts securing the steering column assembly.

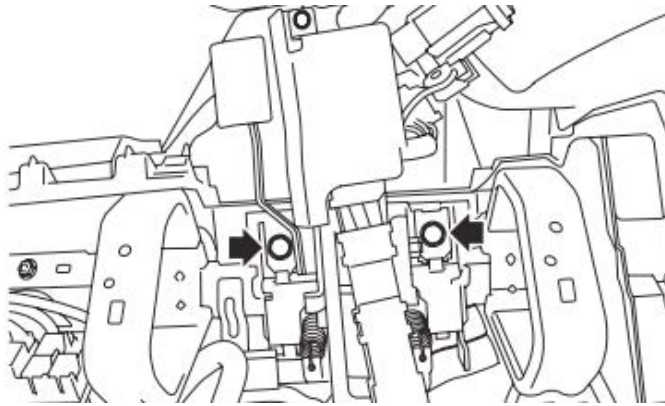

- **CAREFULLY** remove the steering column assembly taking special care to not dislodge the toe board grommet / bushing.
- Using a drill and screw extractor, remove the shear bolt securing the ignition lock to the steering column.

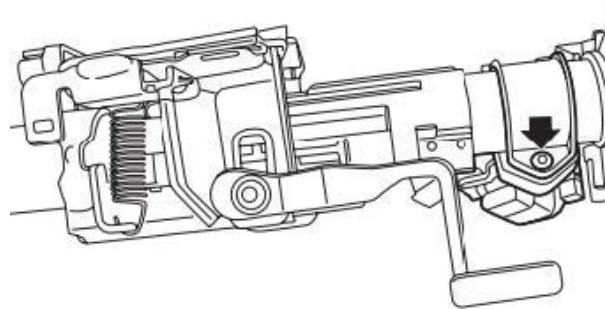

- **CAREFULLY** Install the new steering column taking special care to not dislodge the toe board grommet / bushing. Tighten the 2 retaining bolts to 20 Nm / 14.8 ft. lbs.
 - Transfer the ignition lock to the new steering column and secure with the new shear bolt.
 - **CAREFULLY** reinstall the combination switch, roll connector, and steering angle sensor assemblies. **REMINDER:** If the position of the roll connector was disturbed, the center position adjustment procedure outlined above must be performed.
 - Reconnect all the wiring harness connectors.
 - Reinstall the universal joint shaft. Align the protrusion section (a) of the steering column shaft with the cutout (a) of the serration on the universal joint shaft as shown in the illustration on the left below. If not properly aligned, the upper bolt cannot be installed. Align the alignment mark on the steering rack end of the universal joint shaft with the mark on the steering rack input shaft and install the bolt but **DO NOT TIGHTEN IT**. The guide on the input shaft will slide into the split of the universal joint. Install the bolt and tighten to 24 Nm / 17.7 ft. lbs. Tighten the other bolt (on the column end) to 24 Nm / 17.7 ft. lbs.
- IMPORTANT:** Always tighten the steering rack end retaining bolt first.

Continued...

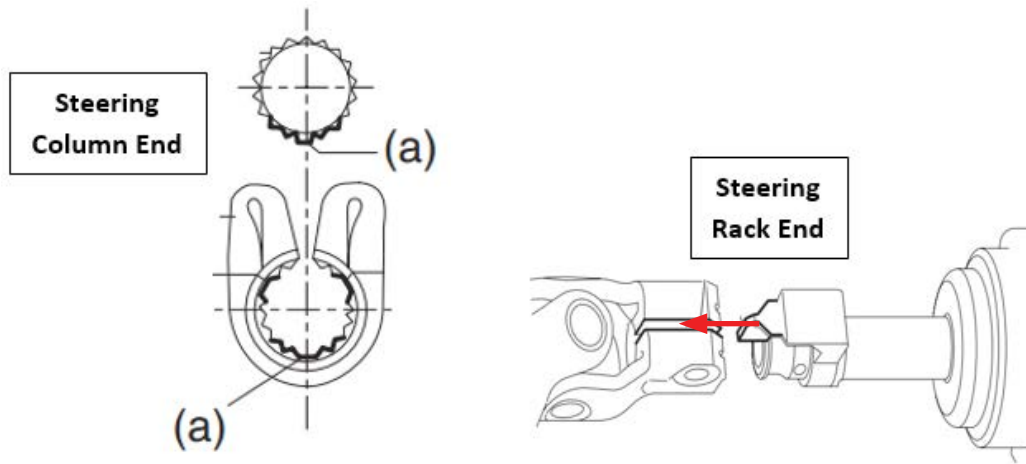

- Reinstall the front exhaust pipe (if removed) and the engine under cover.
- Reinstall the knee guard and tighten the 2 bolts to 7 Nm / 5.2 ft. lbs.
- Reconnect the harness connectors to the switches and reinstall the instrument panel lower trim cover.
- Reinstall the lower instrument panel under cover.
- Reinstall the steering column trim covers.
- Reinstall the steering wheel and torque the retaining nut to 39 Nm / 28.8 ft. lbs.
- Reconnect the harness connectors and reinstall the driver's airbag module.
- Reconnect the battery cable to the battery sensor. Torque the 12mm nut to 7.5 Nm / 5.5 ft. lbs.
- Perform "VDC Sensor Midpoint Setting Mode" for the VDC system following the procedure below:

NOTE: The vehicle must be on a level surface with the wheels and steering wheel in the neutral (straight ahead) position.

- (1) Connect the Subaru Select Monitor to data link connector. **NOTE:** For detailed operation procedures, refer to "Application Help".
- (2) Turn the ignition switch ON.
- (3) On «Start» display, select «Diagnosis».
- (4) On «Vehicle selection» display, input the target vehicle information and select «Confirmed».
- (5) On «Main Menu» display, select «Each System».
- (6) On «Select System» display, select «Brake Control System» and select «Enter».
- (7) On «Select Function» display, select «Data Monitor».
- (8) On «Data monitor» display, select «Steering Angle Sensor», «Longitudinal G Sensor» and «Lateral G Sensor Output».

Confirm the steering angle sensor output value is within the range of following values:

- Model without EyeSight: -10 — 10 deg.
- Model with EyeSight: -2 — 2 deg.

Continued...

- 9) Confirm the output values for the Longitudinal G Sensor and Lateral G Sensor are -2 to 2 m/s.
 - 10) From «Work Support», select «VSC (VDC) Centering Mode», and perform the setting procedure according to the procedure displayed on the Subaru Select Monitor screen.
- Where applicable, confirm STARLINK returns automatically to the pre-repair status and an operator is contacted when pressing the RED SOS button.
 - Reset the customer's radio station presets (and Navigation Favorites where applicable).
 - Turn the ignition key ON, depress the brake pedal and place the transmission selector in D range. Confirm the ignition key cannot be removed. If the key can be removed, the key lock solenoid harness connector is most likely not properly connected.
 - Drive the vehicle for 10 minutes and confirm there is no system malfunction, no warning light illumination and no DTCs reset.

CLAIM REIMBURSEMENT AND ENTRY PROCEDURES:

Credit to perform this service campaign will be based on the submission of properly completed repair order information. Retailers may submit claims through Vehicle Claim Entry on subarunet.com.

Labor Description	Labor Operation #	Labor Time	Campaign Code	Claim Type
STEERING COLUMN- LOT# INSPECTION ONLY	A165-801	0.2	WTD-65	RC
STEERING COLUMN- LOT# INSPECTION & COLUMN ASSEMBLY REPLACE (INCLUDES CENTERING THE STEERING WHEEL)	A165-802	1.1 for H4 Models		
		1.3 for H6 Models		

IMPORTANT REMINDERS:

- SOA strongly discourages the printing and/or local storage of service information as previously released information and electronic publications may be updated at any time.
- Always check for any open recalls or campaigns anytime a vehicle is in for servicing.
- Always refer to STIS for the latest service information before performing any repairs.