

REV.	DATE	ECN	DESCRIPTION	BY	CHKD.	APPD.
A	04/25/16	TBD	RELEASE TO PRODUCTION	DK	DK	DK

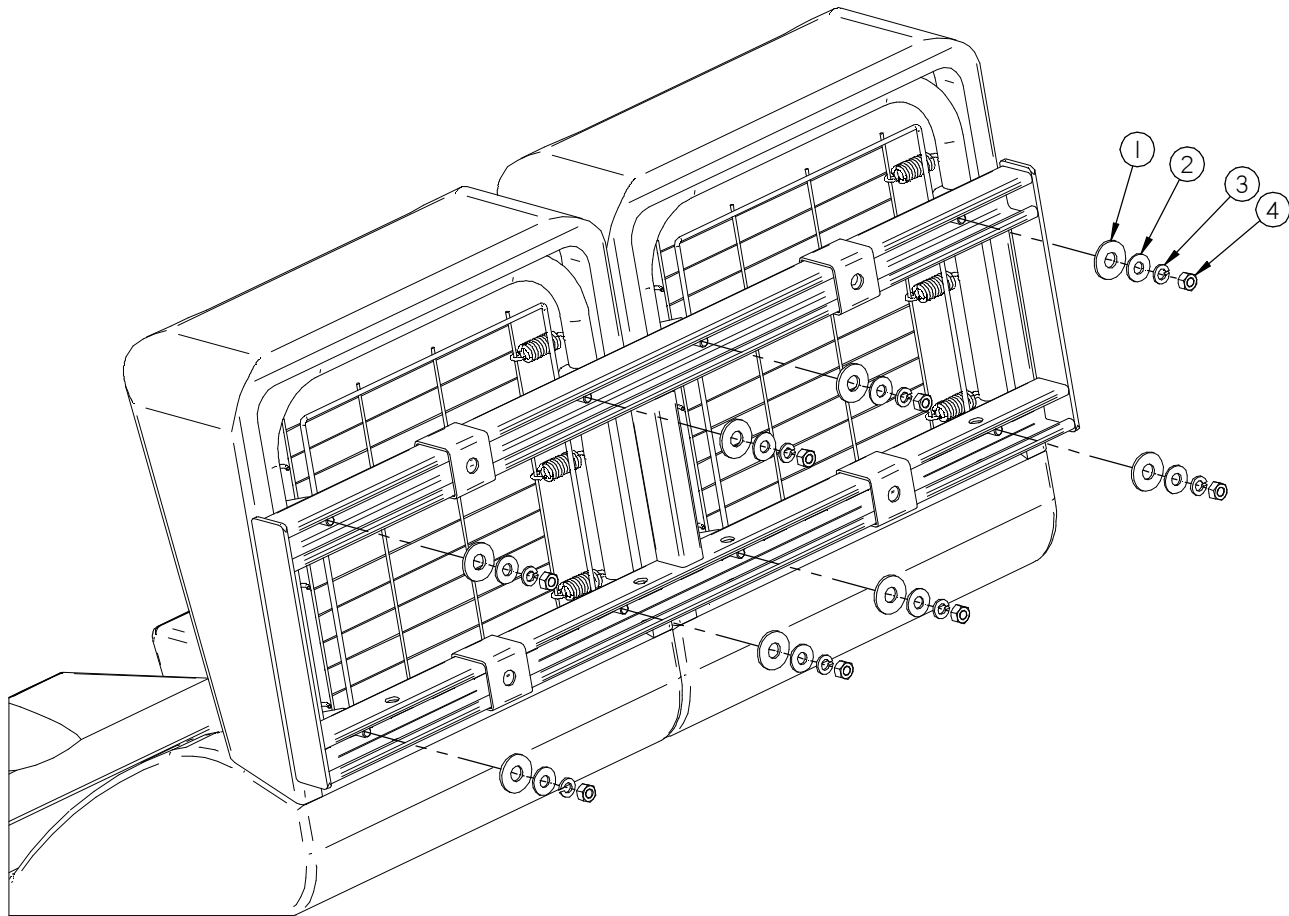

TORQUE TO
17-20 Ft-Lbs

PRELIMINARY
04/25/16
NON CONTROLLED DOCUMENT
X D. KLOPP
REV: A-1

4	8	225854	3/8-24UNF, HEX NUT, G8, ZP
3	8	120382	3/8 LOCK WASHER, REG SPRING, ZP
2	8	120388	3/8" ID, 1" OD FLAT WASHER, ZP
1	8	99016	1/2 FLAT WASHER, USS, G8, ZP, YEL
ITEM	QTY	PART #	DESCRIPTION

DRAWING NAME: **INSTRUCTIONS, SEAT, FAMILY**

MATERIAL:	 Freedman Seating Co. 4545 W. Augusta Blvd Chicago, IL 60651		PROJECTION
SPECIFICATION:	DATE	CHECKED	APPROVED
BY:	DATE	CHECKED	APPROVED
SIZE: C	DRAWING No.: 75710	SCALE: NOT TO SCALE	REV: A
ISSUE DATE	SHEET: 1 of 1		

Tolerances Unless Otherwise Specified:
 Fraction: 1/32" +/- 1/32"
 Decimal: .001" +/- 0.001"
 .0005" +/- 0.0005"
 Angular +/- 1 Degree
 Unspecified Radii are 1/8"

NOT TO BE USED, DISCLOSED OR REPRODUCED WITHOUT PERMISSION.
 PROPERTY OF FREEDMAN SEATING COMPANY.