



Recall 16V-173 : Replace "Electronic Control Unit" for the Airbags

This Service Information bulletin supersedes SI B65 11 16 dated May 2016 .

UPDATE! designates changes to this revision.

Please perform the procedure outlined in this Service Information on all affected vehicles before customer delivery. In the event the customer has already taken delivery of the vehicle, please perform the procedure the next time the vehicle is in the shop.

MODEL

G12 (7 Series)

SITUATION

This is now a Voluntary Safety Recall involving the replacement of the Electronic Control Unit for the Air Bags (ACSM5) on certain G12 (7 Series) BMW vehicles. The electronic control unit for the air bags might malfunction in very rare instances. In such instances, an "air bag warning" light will illuminate in the instrument cluster.

Please refrain from ordering any electronic control units for vehicles remaining in dealer inventory. Electronic control units should only be used for customer cars or for new cars that need to be delivered to customers.

AFFECTED VEHICLES

The recall was issued on G12 (7 Series) vehicles produced from July 1, 2015 to December 11, 2015.

Affected vehicles in dealer inventory must not be retailed or delivered until this issue is corrected. Vehicles at ports of entry will be repaired prior to dealer delivery.

Vehicles which require this Recall Campaign to be completed will show it as "Open" when checked either in the "Service Menu" of DCSnet (Dealer Communication System) or with the Key Reader.

UPDATE! Replacement units are now available for G12 vehicles affected by the Air Bag Control Module Recall and the Turbo Waste Gate Service Action, announced in April.

To expedite repair completion for our valued GKL customers, our Customer Relations team will make outbound calls to the customers with affected vehicles. During these calls, we will offer to schedule a service repair appointment via your center's online scheduling system. As part of the Ultimate Benefits package, expect that some customers with appointments will want to utilize the pick-up and drop off option and/or receive a suitable loaner car.

Please ensure your dealership is prepared to give these customers top priority when you see

their reservations in your system – and to use the opportunity when you see them to deliver the ultimate customer experience - whether speaking with them in your dealership, in their driveway, on email, or by phone.

Thank you for your support and partnership.

BMW NA

CAUSE

Electronic Control Unit for the Air Bags (ACSM5) may not meet BMW specification.

CORRECTION

Replace the Electronic Control Unit for the Air Bags (ACSM5) and update the vehicle software.

PROCEDURE

1. Replace the air bag control unit ACSM5, see Repair Instructions **RA 65 77 018** . Copy of RA attached.
 - Reference the attachment on this SIB for tips on ACSM5 removal.
 - All four ACSM5 mounting nuts are to be reused and tightened to 8 Nm of torque.
 - On G12 vehicles with option 4F5 "Executive Lounge rear console", the rear console must be removed, see "Remove and refit the rear console" Repair Instructions **RA 52 25 350** . Copy of RA attached.
 - The front and rear consoles have sharp edges that can cut into the dashboard or rear seat during removal. Take precautions to prevent contact that can damage the interior.
2. After ACSM5 replacement program the vehicle with ISTA/P.
 - **Always connect a BMW approved battery charger / power supply ([SI B04 23 10](#)).**

PARTS INFORMATION

Please refrain from ordering any electronic control units for vehicles remaining in dealer inventory. Electronic control units should only be used for customer cars or for new cars that need to be delivered to customers.

All affected customers of this Recall were mailed an interim letter on May 20, 2016. This letter is informing them that their vehicle is included in the recall. A final letter will be mailed to the customers when parts become available. A copy of the letter that was sent to these customers has been attached.

Part Number	Description	Quantity
65 77 6 803 281	ACSM5 — Roll — only vehicles with SA2VS but without SA2VH	1
OR		

65 77 6 803 282	ACSM5 — AFS — only vehicles with SA2VS and SA2VH	1
OR		
65 77 6 803 283	ACSM5 — High — All without SA2VS	1

WARRANTY INFORMATION

Reimbursement for this Recall will be via normal claim entry utilizing the following information:

Defect Code	00 65 90 02 00
--------------------	-----------------------

Plus work: Completion "before" vehicle delivery to the customer or the vehicle is already in the workshop

"Without" option code 4F5 (Executive Lounge rear console)

Labor Operation	Labor Allowance	Description
00 64 564	11 FRU	Replacing the airbag control unit only (Programming and coding control units performed in conjunction with another campaign or repair during the workshop repair visit)
Or:		
00 64 566	19 FRU	Replacing the airbag control unit and programming and coding control units (Includes connecting an approved battery charger/power supply and performing a vehicle test)

"With" option code 4F5 (Executive Lounge rear console)

Labor Operation	Labor Allowance	Description
00 64 565	31 FRU	Replacing the airbag control unit only (with the rear console option) (Programming and coding control units performed in conjunction with another campaign or repair during the same workshop visit)
Or:		

00 64 567	39 FRU	Replacing the airbag control unit and programming and coding control units (with the rear console option) (Includes connecting an approved battery charger/power supply and performing a vehicle test)
-----------	--------	--

Main work: Completion after vehicle delivery to the customer

"Without" option code 4F5 (Executive Lounge rear console)

Labor Operation	Labor Allowance	Description
00 64 055	13 FRU	Replacing the airbag control unit only (Programming and coding control units performed in conjunction with another campaign or repair during the same workshop visit)
Or:		
00 64 057	21 FRU	Replacing the airbag control unit and programming and coding control units (Includes connecting an approved battery charger/power supply and performing a vehicle test)

"With" option code 4F5 (Executive Lounge rear console)

00 64 056	32 FRU	Replacing the airbag control unit only (with the rear console option) (Programming and coding control units performed in conjunction with another campaign or repair during the same workshop visit)
Or:		
00 64 058	41 FRU	Replacing the airbag control unit and programming and coding control units (with the rear console option) (Includes connecting an approved battery charger/power supply and performing a vehicle test)

Vehicle Programming and Coding

Control module failures that occur during programming:

- Please claim these consequential repairs under the defect code listed in this bulletin and use the applicable KSD2 labor operations.

Other Repairs

Control module failures that occur prior to programming:

- When covered under an applicable limited warranty, claim this work with the applicable defect code and the labor operations listed in KSD2.

CUSTOMER SATISFACTION SUPPORT — ENHANCED BMW ULTIMATE BENEFITS SUITE FOR G12

BMW strives to provide the Ultimate Service Experience to complement the Ultimate Driving Machine. Your efforts are sometimes challenged by situations that are beyond the center's control.

- We understand you may have customers who are waiting on a Vehicle Delivery due to parts. For these customers we ask that you wow them by using BMW EMPOWER explained in SI B1 14 15. We should show our customers how much we appreciate them with a surprise and delight gesture.
- Also for customers already in their vehicle who affected by this recall, please utilize the Ultimate Benefits outlined in SI B00 09 15 and offer your customers a Valet Service to pick up and drop of their vehicle or offer a Vehicle SPA service.

Aftersales Area Manager (AAM) "Field Authorization" (FAS) is not required.

Let's show our customers just how much we appreciate them for being part of the BMW family.

ATTACHMENTS

View PDF attachment [16V-xxx-MY16-G12-AirBagControlModule\(QA\)](#).

View PDF attachment [B651116 Interim Customer Letter](#).

View PDF attachment [Recall Notice](#).

View PDF attachment [REP 5225350 Remove and Install Support, Rear Console](#).

View PDF attachment [REP 6577018 Replace Airbag Control Unit](#).

View PDF attachment [SI B65 11 16 Attachment](#).

[Copyright ©2016 BMW of North America, Inc.]

Please be reminded that it is a violation of the National Traffic and Motor Vehicle Safety Act for you to sell, lease or deliver any new vehicle subject to this notification until the Recall repair has been performed. This means that centers may not legally deliver new motor vehicles to a consumer until it is fixed or use/sell replacement equipment/parts subject to a Recall. Note also that substantial civil penalties apply to violations of this law.

Also, you should not sell, lease or deliver any Certified Pre-Owned or used vehicles subject to a safety Recall until the repair is completed.

**Model Year 2016 BMW 7 Series
Air Bag Control Module
Safety Recall 16V-xxx**

Q1. Which models are affected by this Safety Recall?

Certain Model Year 2016 BMW 7 Series are affected.

Q2. How many BMW vehicles in the US are included in this Safety Recall?

Approximately 6,110 vehicles produced between September 1, 2015 and December 11, 2015 in the US are included.

Q3. What is the specific issue?

Due to a supplier manufacturing error, the air bag control module was not produced to specifications. Under certain circumstances, the module may briefly become inoperative.

Q4. What can happen as a result of this issue?

If the air bag control module becomes briefly inoperative, the air bag warning lamp will illuminate. In the event of a crash during this brief reset period, air bag deployment would not occur which increases the risk of injury to vehicle occupants.

Q5. How did BMW become aware of this issue?

BMW became aware of this issue through its quality control procedures.

Q6. Why are other models not included in this Safety Recall?

Other models have been manufactured with an air bag control unit that has been produced to specifications.

Q7. Can I determine if this issue exists in my car?

No. This can only be determined by qualified BMW Center technicians.

Q8. Can I continue to drive my vehicle?

Yes. However, when you receive a letter asking you to have this service performed by an authorized BMW center, please do so as soon as possible. If you are not the only driver of this vehicle, please advise all other drivers of this important information.

Q9. How will my vehicle be repaired?

The air bag control unit will be replaced.

Q10. Is BMW aware of any accidents or injuries involving these BMW vehicles associated with this Safety Recall?

No.

**Model Year 2016 BMW 7 Series
Air Bag Control Module
Safety Recall 16V-xxx**

Q11. How will I be informed of this Safety Recall?

If your vehicle is affected, you will receive a letter in May via First Class mail advising you of this recall and requesting that you schedule an appointment with an authorized BMW center for service and repair.

Q12. How long will the repair take?

This repair may take up to 3-4 hours; however, additional time may be required depending upon your BMW center's schedule. The repair will be performed free of charge by your authorized BMW center.

Q13. Do I have to wait for my letter in order to have my vehicle serviced?

Yes. BMW is in the process of implementing this program to ensure that the necessary parts, tools and procedures are available to its authorized BMW centers, prior to instructing you to take your vehicle in for repair.

IMPORTANT SAFETY RECALL

This notice applies to your vehicle, [INSERT VIN]

May 2016

Recall Campaign No. 16V-173: Air Bag Electronic Control Unit

Dear BMW Owner/Lessee:

This notice is sent to you in accordance with the National Traffic and Motor Vehicle Safety Act.

BMW AG has decided that a defect, which relates to motor vehicle safety, exist in certain Model Year 2016 BMW 7 Series vehicles. Our records indicate that you are the owner/lessee of an affected vehicle.

IMPORTANT NOTICE

Please note that at the present time, parts are not available. BMW will notify you by letter as soon as we can perform this recall on your vehicle.

If you are not the only driver of this vehicle, please advise all other drivers and passengers of this important information.

DESCRIPTION OF PROBLEM

This recall involves the air bag electronic control unit. The air bag electronic control unit was not produced to specifications. In certain driving situations involving excessive vibration or acceleration, the air bag electronic control unit could become briefly inactive. As a result, if a crash occurs during this brief period, the air bags may not deploy, and increase the risk of injury. However, after this brief period, the air bag electronic control unit becomes active again.

DESCRIPTION OF REPAIR

The air bag electronic control unit will be replaced.

This **free repair** may take approximately three to four hours; however, additional time may be required depending upon the BMW center's schedule.

OTHER INFORMATION

If you are no longer the owner/lessee of this vehicle, we request that you provide us with the name and address of the new owner/lessee using the enclosed postage-paid card so that we can contact the new owner/lessee regarding this issue. If you are a lessor of this vehicle, Federal Regulations require you to forward this notice to your lessee within ten days.

To ensure BMW of North America, LLC has your most recent contact and vehicle information, please register your vehicle at <http://www.bmwusa.com/myBMW>. Registration is free of

charge, and will give you access to factory initiated campaigns and other information specific to your BMW vehicle.

Should you have any questions about this recall, please contact your authorized BMW center. Should you need additional assistance, you may contact BMW Customer Relations and Services via Email at CustomerRelations@bmwusa.com or by calling 1-800-525-7417 from 9 AM to 9 PM Eastern Time, Monday through Friday.

If your BMW center is unable to remedy the defect without charge or within a reasonable period of time, you may notify the Administrator, National Highway Traffic Safety Administration, 1200 New Jersey Ave., S.E., Washington, DC 20590, call the toll-free Vehicle Safety Hotline at 1-888-327-4236 (TTY: 1-800-424-9153), or go to <http://www.safercar.gov>.

BMW recommends that you always wear your safety belt, and that all passengers are properly seated and restrained at all times.

We sincerely apologize for any inconvenience this recall may cause you; however, be assured that BMW is concerned about your safety and security.

BMW of North America, LLC

52 25 350 Remove and install support, rear console

Overview of Activities

Additional Information

Preliminary Work

- 1 Remove the two seat surfaces
- 2 Remove both rear seats
- 3 Remove fresh air grille in rear passenger compartm...
- 4 Removing the control panel of the rear passenger com...
- 5 Removing the cup holder in the rear console
- 6 Removing the DVD player
- 7 Removing the top rear console

Main Work

- 8 Remove rear console
- 9 Install rear console

Postprocesses

- 10 Installing the rear console at the top
- 11 Installing the DVD player
- 12 Installing the cup holder in the rear console
- 13 Installing the control panel of the rear passenger compa...
- 14 Installing the fresh air grille in the rear passenger compartment
- 15 Installing both rear seats
- 16 Installing both seat surfaces

General information

PRELIMINARY WORK

1-Remove the two seat surfaces

NOTICE

Description is for left component only. Procedure on the right side is identical.

◀ Removing the seat surface

RISK OF DAMAGE

Damage to the seat belt.

If the seat surface is disassembled, the seat belt can be damaged by the seat mechanism.

- Do not operate the seat adjustment mechanism with the seat surface disassembled (unless otherwise indicated).



- Move seat angle all the way to the top.
- Set forward/back seat adjustment to maximum forward position.
- Unclip seat surface from latch mechanism from above.

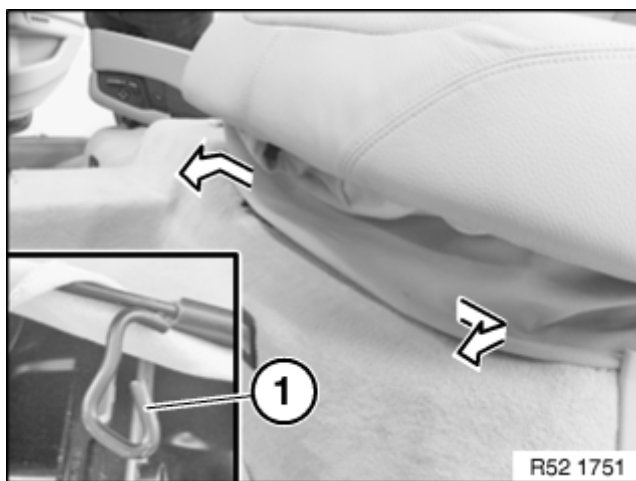

- First lever out the wire spring clip (1) to the outside (door side) in direction of arrow out of the seat mechanism.
- Then lever out the wire spring clip (1) to the inside (tunnel side) in direction of arrow out of the seat mechanism.
- Remove seat surface toward the top and disconnect all associated plug connections.

• Equipment specification with active seat:

Fold the seat surface (1) upwards.

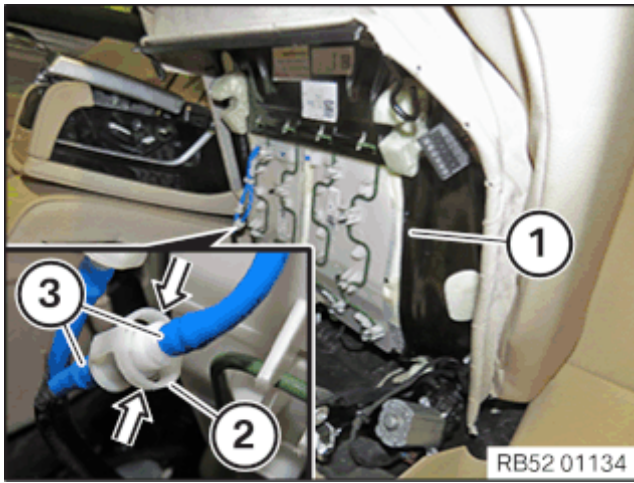

Press together the coupling (2) at the marked points and pull apart the lines (3) by gently moving them up and down.



2-Remove both rear seats

NOTICE

Description is for left component only. Procedure on the right side is identical.

◀ Removing the seat

Prerequisite

Fully move the rear seat backrest forwards.

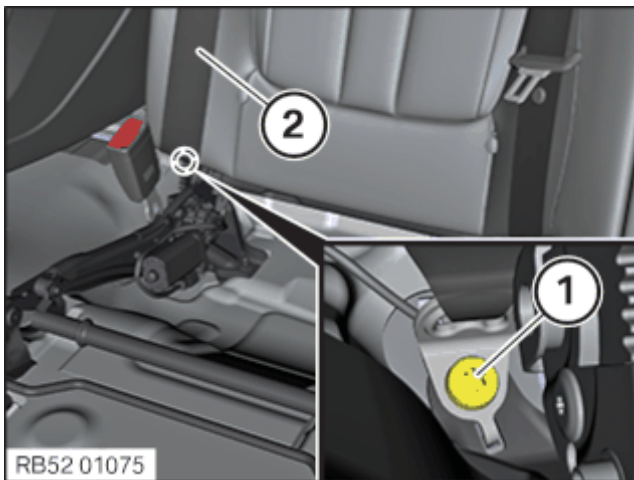

- Loosen screw (1).
- Guide out seat belt (2) and put to one side at top.

- Loosen nuts (1) to (4).

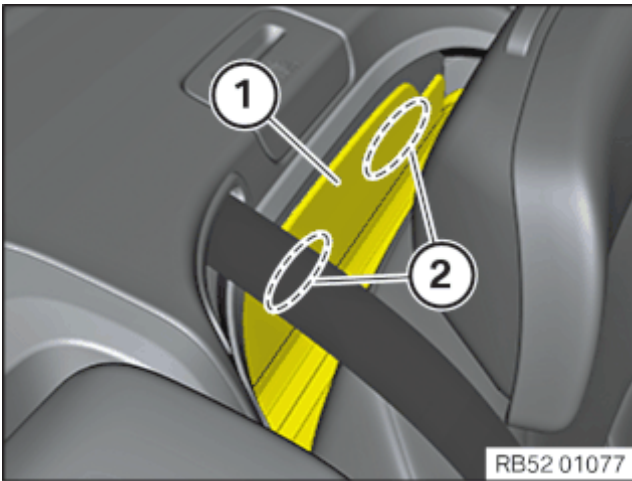
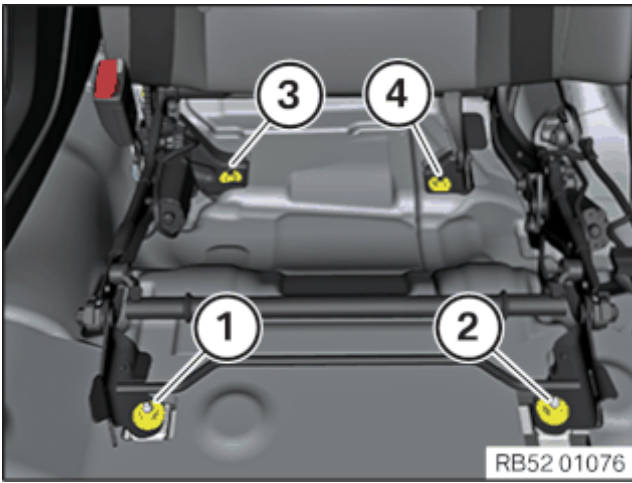

- Loosen cover (1) in the area (2) toward the inside of Velcro fastener.
- Detach cover (1) toward the top from the seat mechanism.

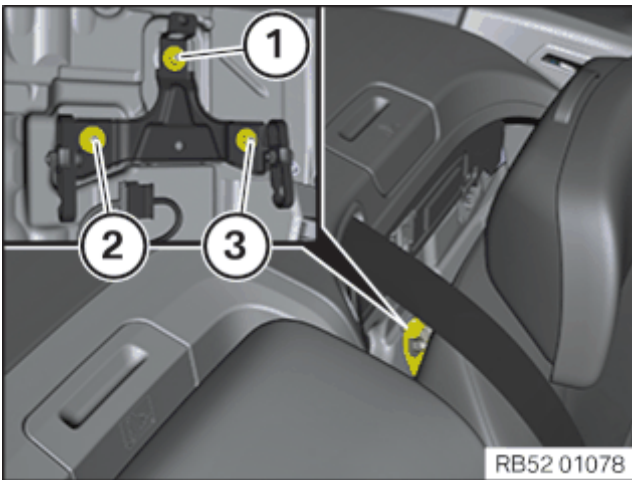

- Loosen nuts (1) to (3).

- Fold seat forward slightly.
- Unlock plug connections and disconnect.

RISK OF DAMAGE

Scratches.

Tools and sharp-edged components can cause scratches.

- Protect working area.
- Handle tools and components carefully.

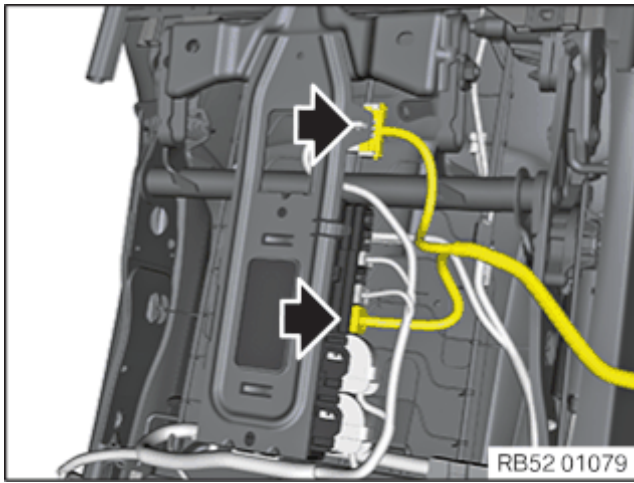

- Lift seat out.



3–Remove fresh air grille in rear passenger compartment



- Unclip the fresh air grille (1) using special tool 0 496 571 (00 9 327).
- Disconnect the associated connector and remove the fresh air grille (1).

4–Removing the control panel of the rear passenger compartment air conditioning

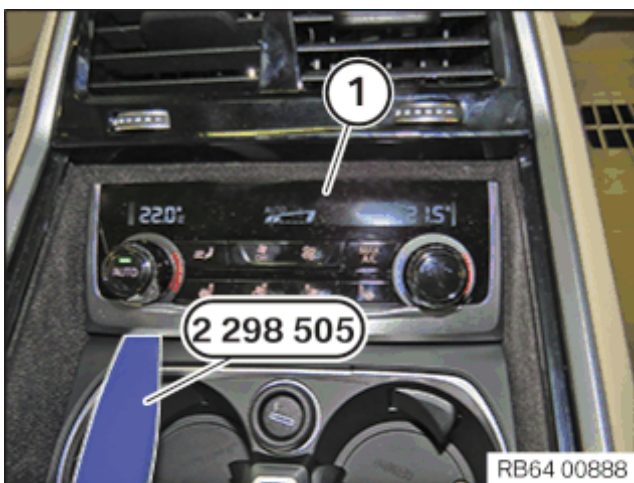

- Unclip the control panel (1) using special tool 2 298 505.
- Disconnect the associated connector and remove the control panel (1).

5–Removing the cup holder in the rear console

- Remove covers (1) upwards.

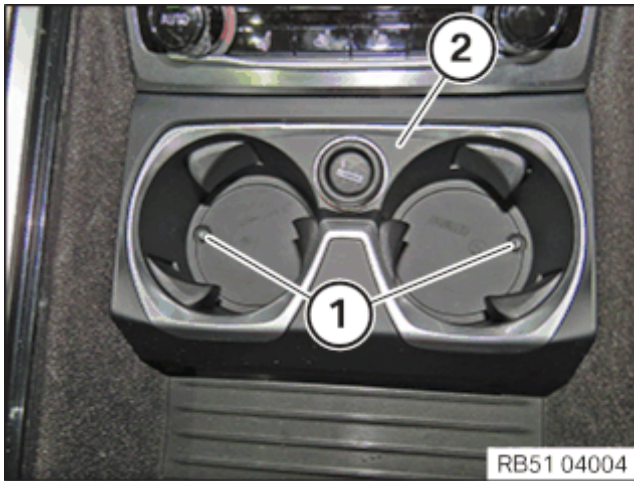

- Loosen screws (1).
- Remove the cup holder (2) towards the top and disconnect the associated connector.

6-Removing the DVD player

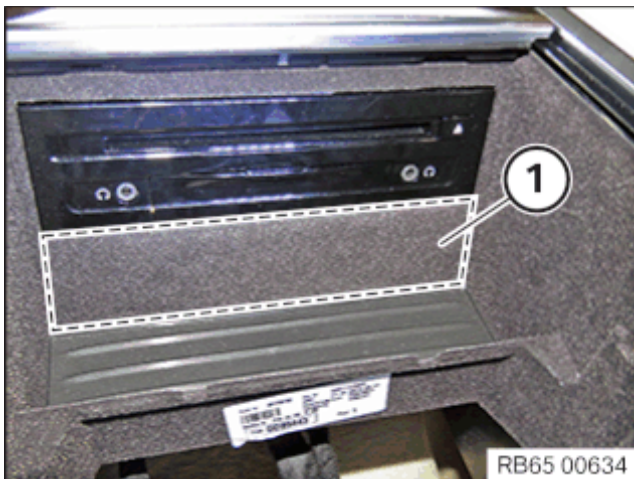

- Disengage the cover (1).

- Loosen the screws (1) and pull out the DVD player (2).

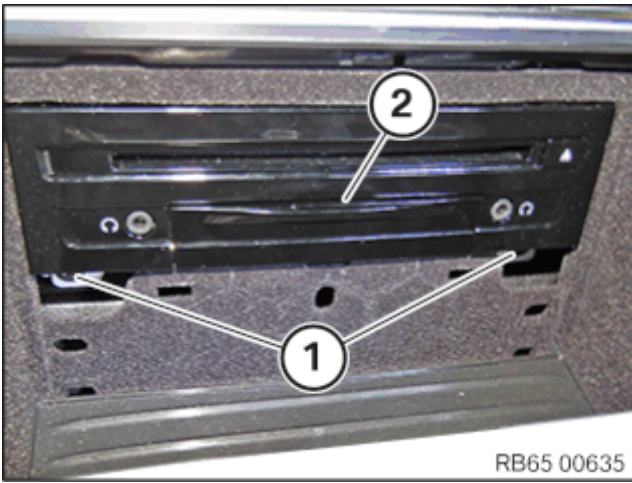

- Unlock and disconnect connector (1).
- Remove the DVD player (2).

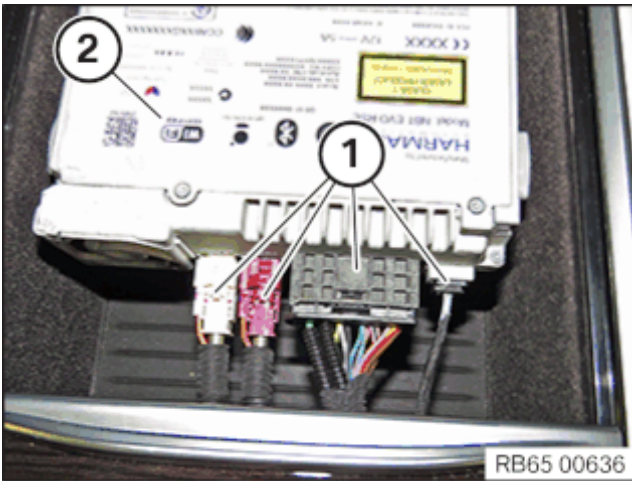

7-Removing the top rear console

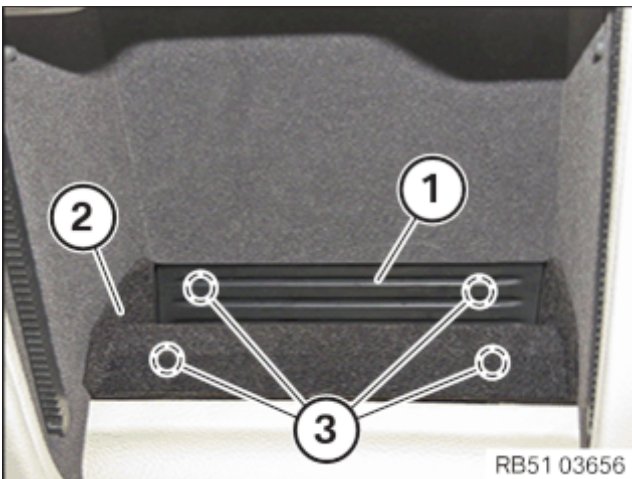

- Remove the insert (1).
- Unclip the trim (2) from the clamps towards the top in this area (3).

- Unlock plug connection (1) and disconnect.
- Loosen the nuts (2) on the left and right.

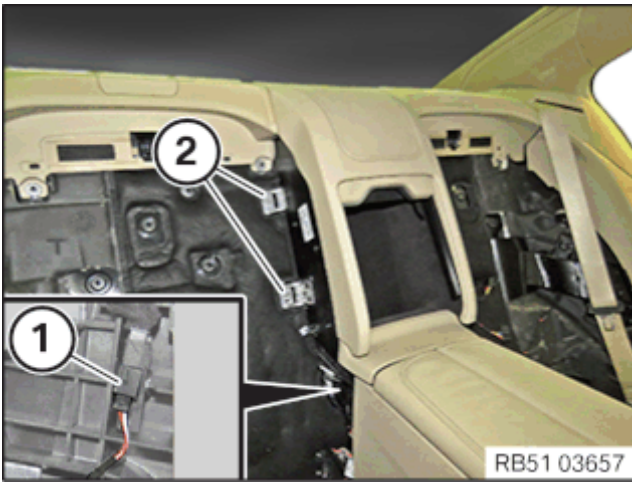

- Loosen the rear console (1) from the clamps towards the top in this area (2).

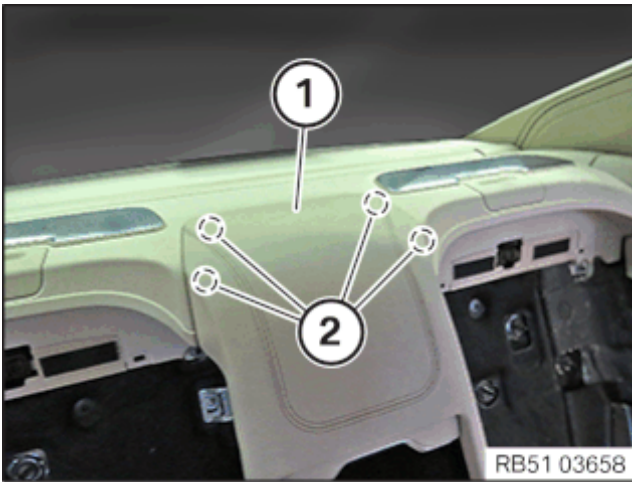

MAIN WORK

8-Remove rear console



- Remove the insert (1).
- Lever out the cover (2).

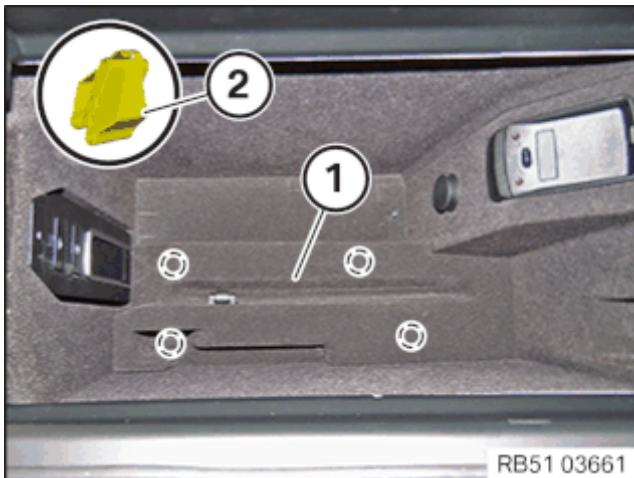

- Unclip the trim (1) from the clamps (2) towards the top.

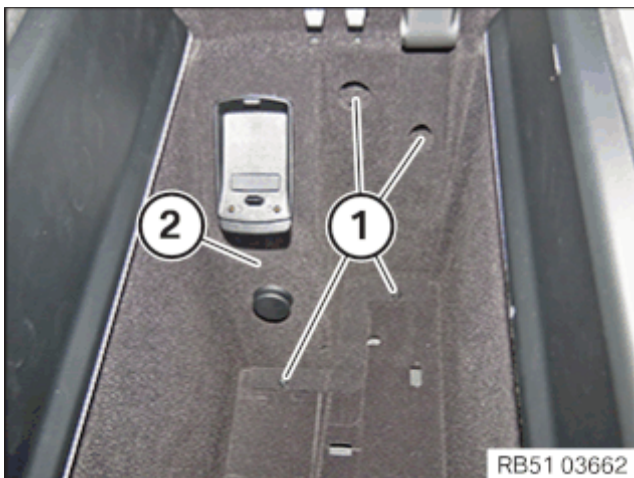

- Loosen screws (1).
- Unclip the trim (2) towards the inside and disconnect the associated plug connections.

- Unclip the trim (1) from the clamps (2) towards the rear.

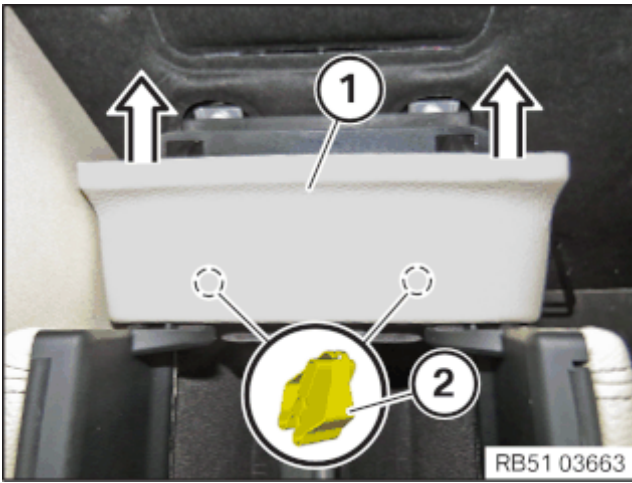

- Loosen screws (1).

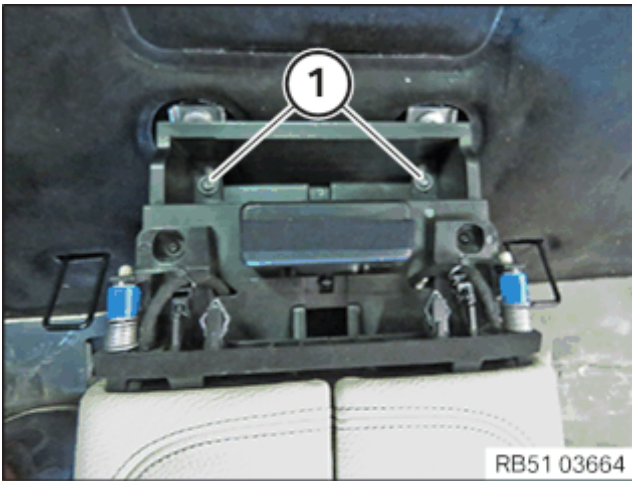

- Unlock and disconnect the plug connections (1) on the left side.
- Unlock and disconnect the plug connections (2) on the right side.

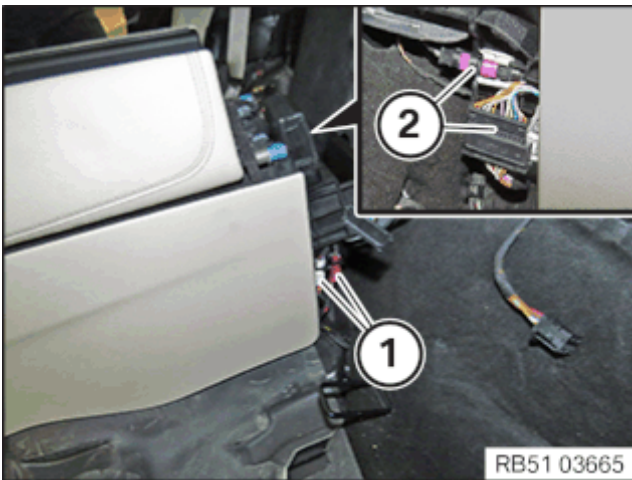

- Loosen screws (1).



- Loosen screws (1).

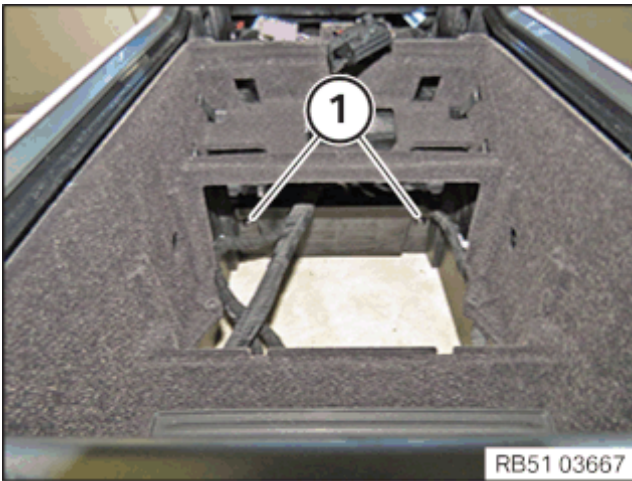

- Loosen the wiring harness on all cable clips and feed back in.

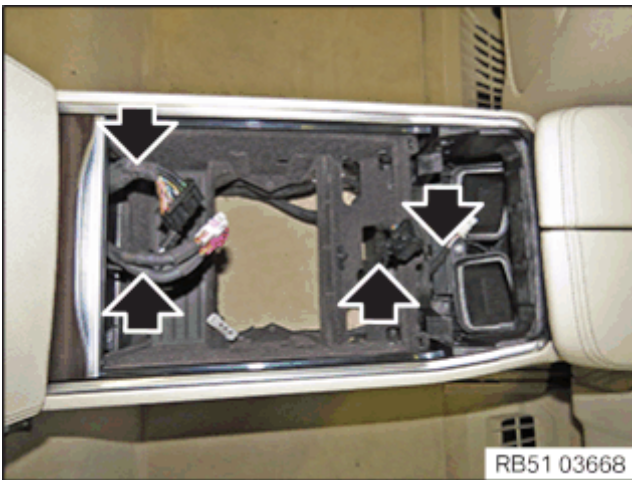

- Loosen left and right screw (1).
- Slightly lift the rear console (2) at the rear.
If necessary, unlock and disconnect additional plug connections.
- Remove the rear console (2) with an additional person.

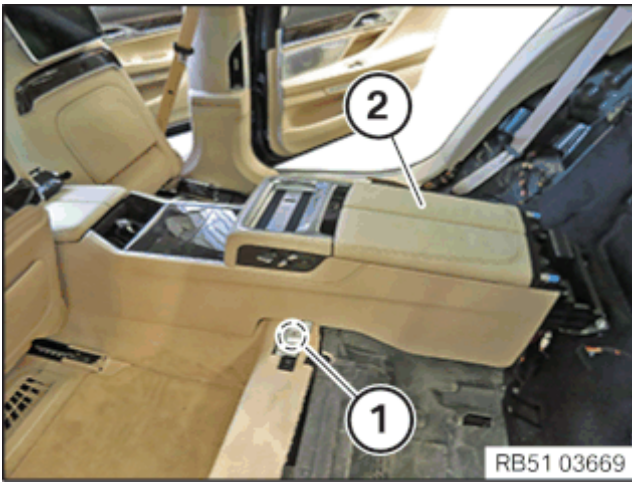

9-Install rear console

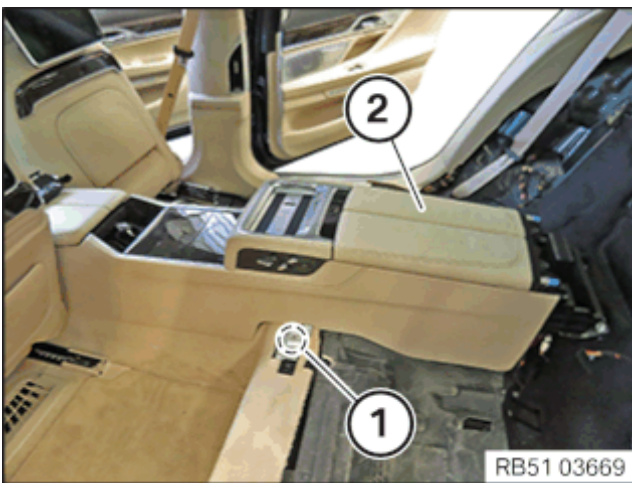

- Insert the rear console (2) with an additional person.
- Slightly lift the rear console (2) at the rear.
If required, connect relevant connector.
- Tighten the screw (1) on the left and right.

Rear console to body



	4,6 Nm
--	--------

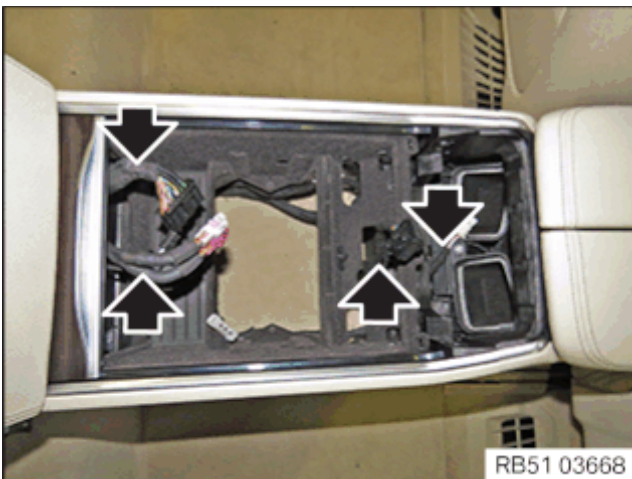

- Insert the wiring harness and secure to all cable clips.

- Tighten the screws (1).

Rear console to centre console



	2,3 Nm
--	--------

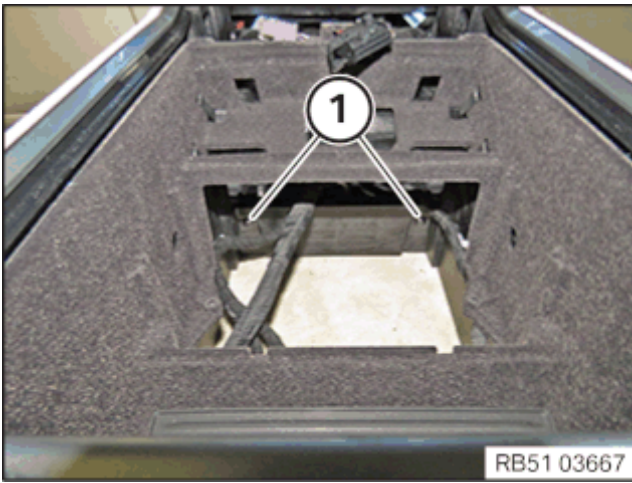

RB51 03667

- Tighten the screws (1).

Rear console to centre console



2,3 Nm

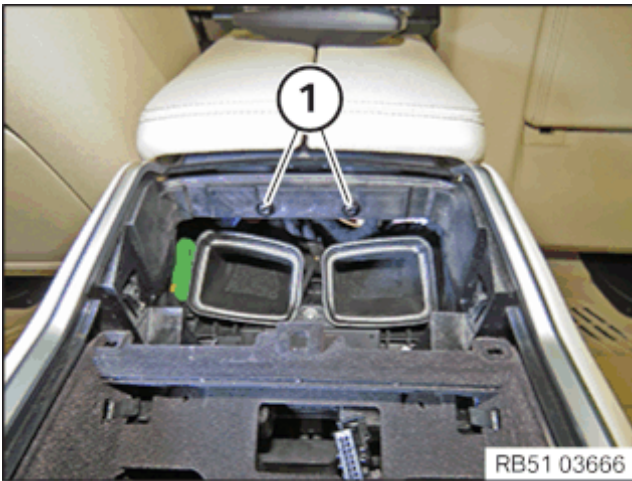

RB51 03666

- Connect the connector (1) to the left-hand side.
- Connect the connector (2) to the right-hand side.

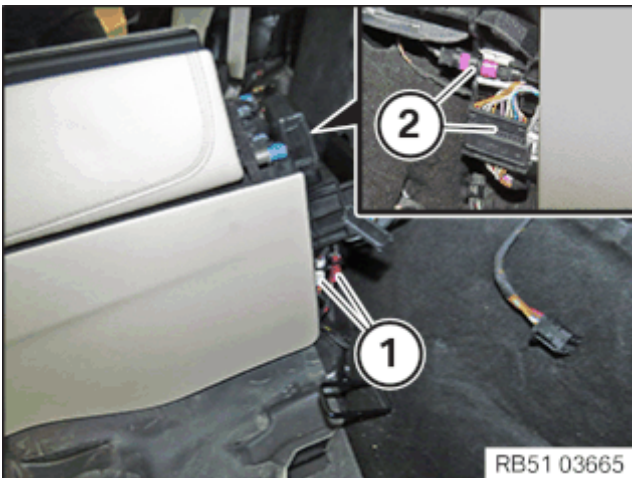

RB51 03665

- Tighten the screws (1).

Rear console to rear holder



4,6 Nm

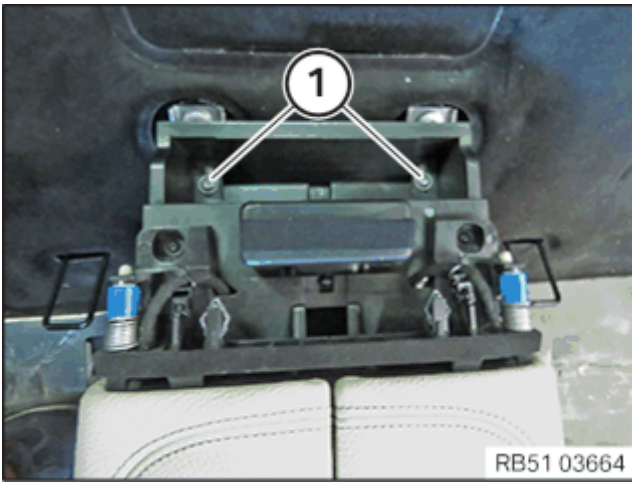

- Clip in the trim (1) into the clamps (2) from the rear.

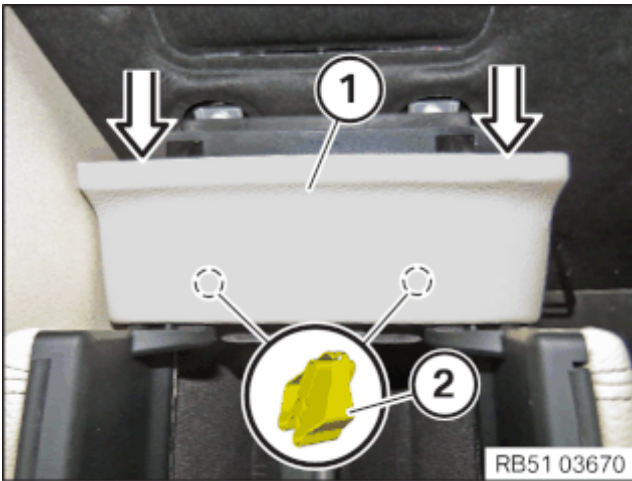

- Connect the trim (2) to the associated connectors.
- Clip in the trim (2).
- Tighten the screws (1).

Trim in rear console storage compartment

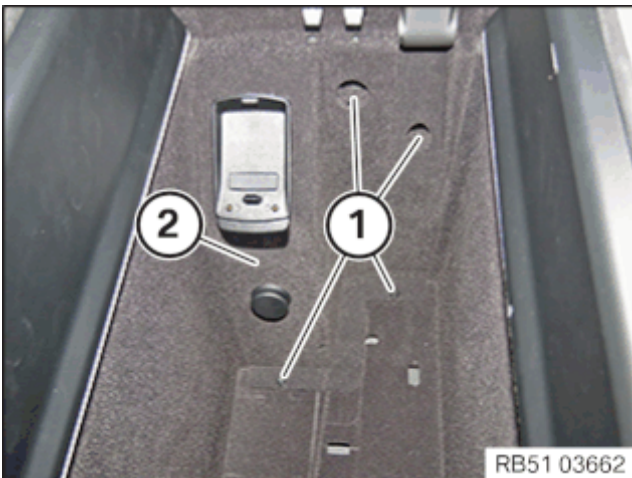

- Clip in the trim (1) into the clamps (2) from the top.

1,8 Nm

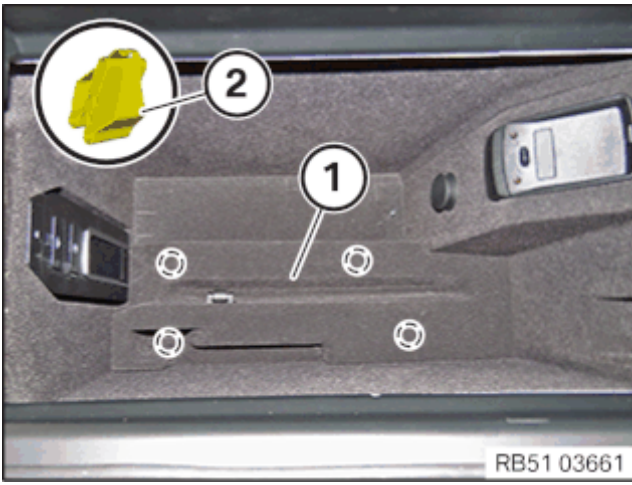

- Insert the insert (1) and cover (2).



POSTPROCESSES

10–Installing the rear console at the top

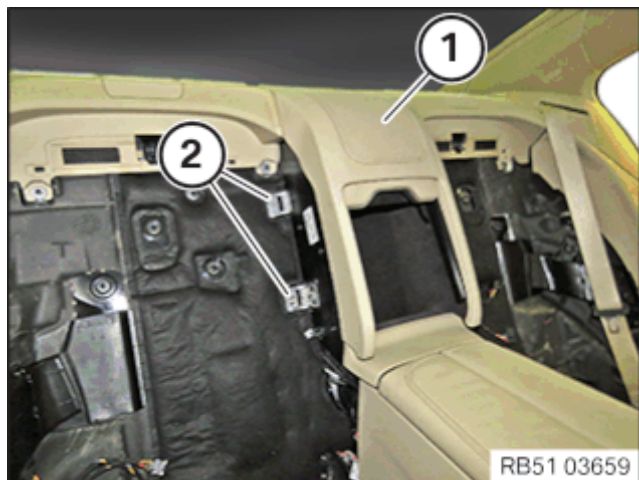

- Insert the rear console (1) and position it on the attachment points (2) on the left and right.

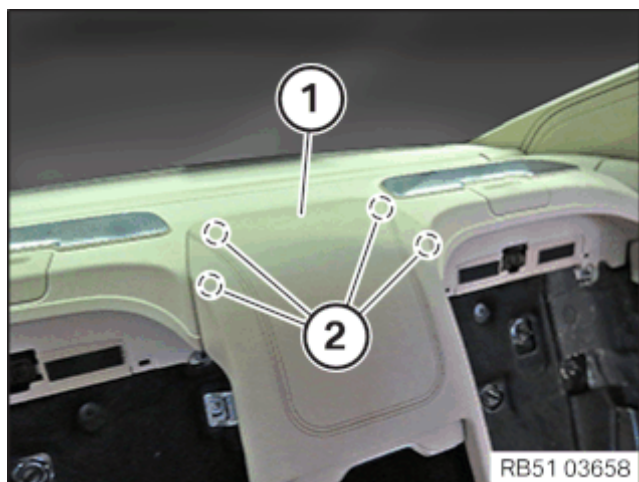

- Clip in the rear console (1) into the clamps from the top in this area (2).

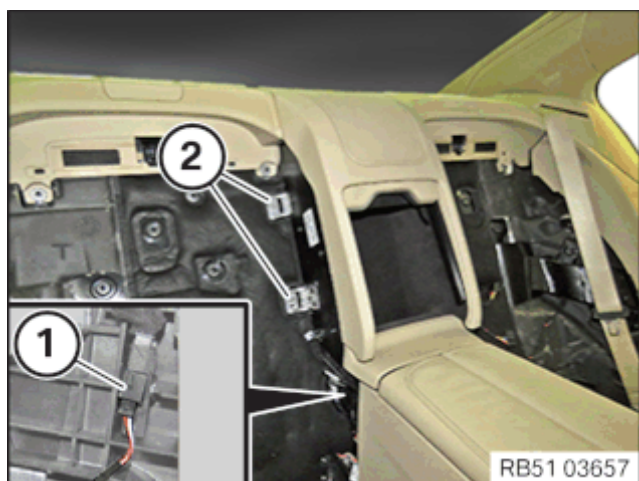

- Connect connector (1).
- Tighten the nuts (2) on the left and right.

Top rear console to body



Nut		4,6 Nm
-----	--	--------

- Clip in the trim (2) into the clamps from the top in this area (3).
- Insert the insert (1).

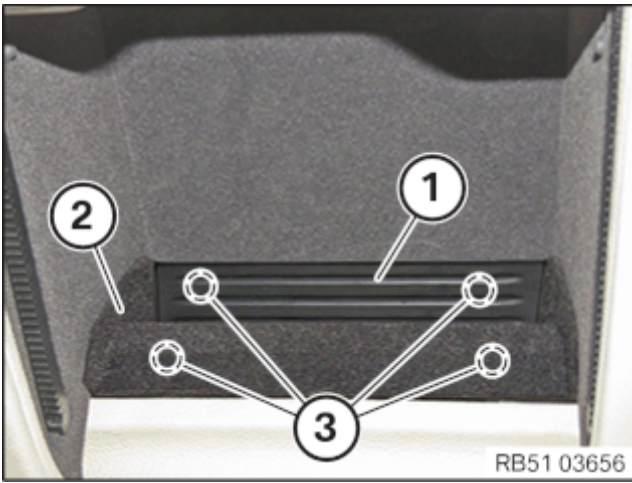

11-Installing the DVD player

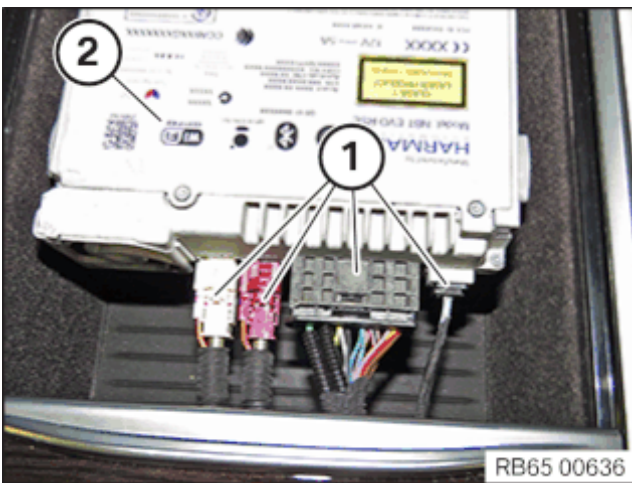

- Insert and connect the connector (1) to the DVD player (2).

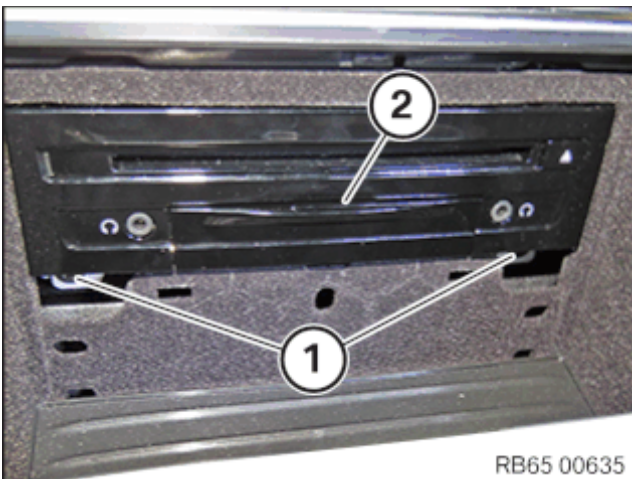

- Correctly position the DVD player (2) and tighten the screws (1).

- Correctly position and engage the cover (1).

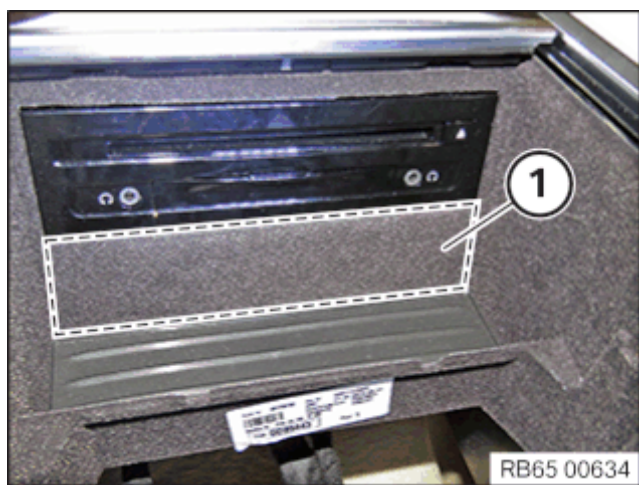

12-Installing the cup holder in the rear console

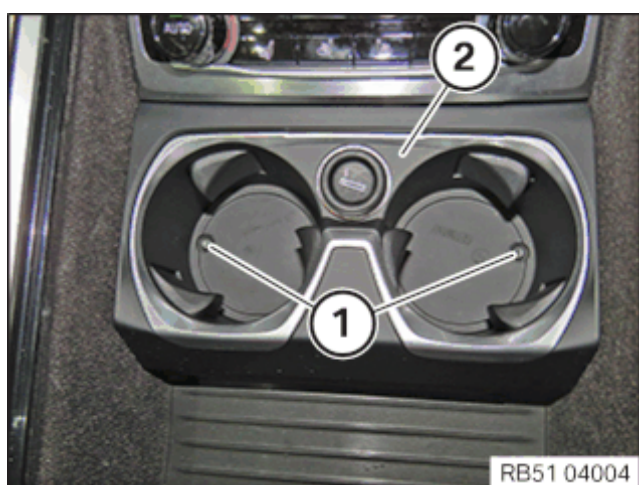

- Insert and connect the associated connector to the cup holder (2).
- Correctly position the cup holder (2) and tighten the screws (1).

Cup holder to rear console



	1,8 Nm
--	--------



- Correctly insert the covers (1).

13-Installing the control panel of the rear passenger compartment air conditioning

- Insert and connect the associated connector to the control panel (1).
- Correctly position the control panel (1) and engage with the rear console (2).



14—Installing the fresh air grille in the rear passenger compartment



- Insert and connect the associated connector to the fresh air grille (1).
- Correctly position the fresh air grille (1) and engage with the rear console (2).

15—Installing both rear seats

NOTICE

Description is for left component only. Procedure on the right side is identical.

◀ Installing the seat

RISK OF DAMAGE

Scratches.

Tools and sharp-edged components can cause scratches.

- Protect working area.
- Handle tools and components carefully.

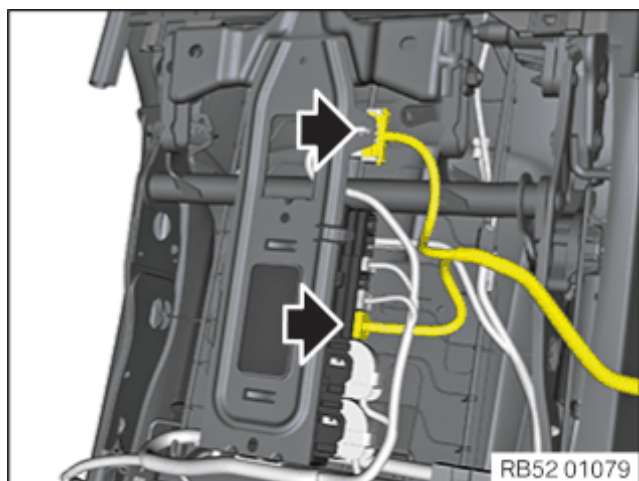

- Insert the seat into the vehicle.
- Slightly fold the rear seat backrest forwards.
- Connect connector.

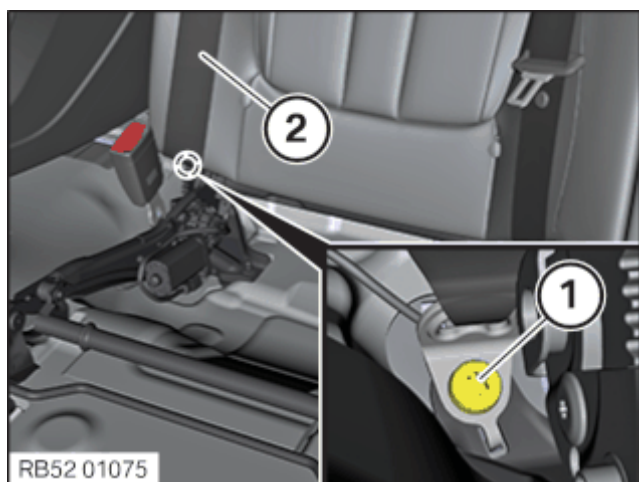

- Insert the seat belt (2) and correctly position it on the seat mechanism.
- Tighten down screw (1).

Lower strap to body



M12	Renew screw.		42 Nm
-----	--------------	--	-------

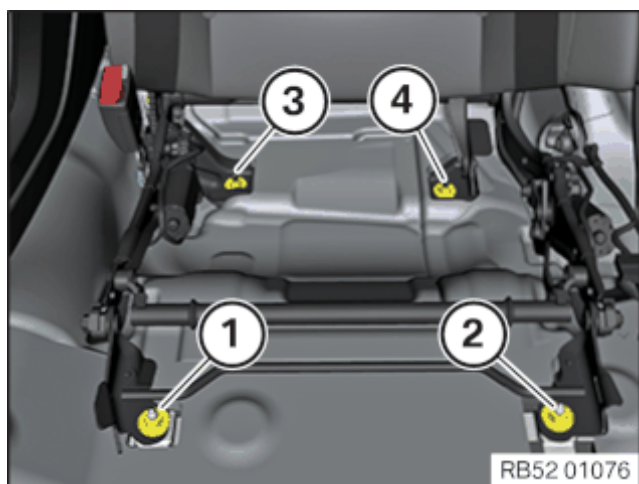

- Tighten nuts in the sequence (1), (2), (3) and (4).

Rear seat to body



Nut M8			18,5 Nm
--------	--	--	---------

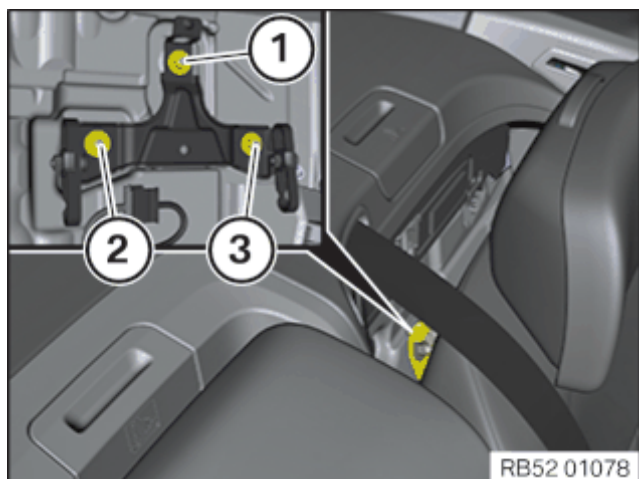

- Tighten nuts in the sequence (1), (2), and (3).

Rear seat to body



Nut M8			18,5 Nm
--------	--	--	---------

- Attach the cover (1) into the seat mechanism from the top.
- Secure the cover with Velcro fastener (1) in this area (2).

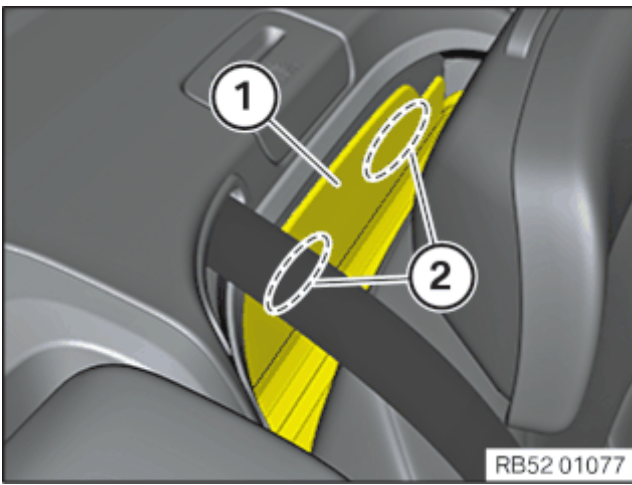

16-Installing both seat surfaces

NOTICE

Description is for left component only. Procedure on the right side is identical.

◀ Installing the seat surface

◀ Checking the seat belt (for 5-seater only)

RISK OF DAMAGE

Damage to the seat belt.

If the seat surface is disassembled, the seat belt can be damaged by the seat mechanism.

- Do not operate the seat adjustment mechanism with the seat surface disassembled (unless otherwise indicated).

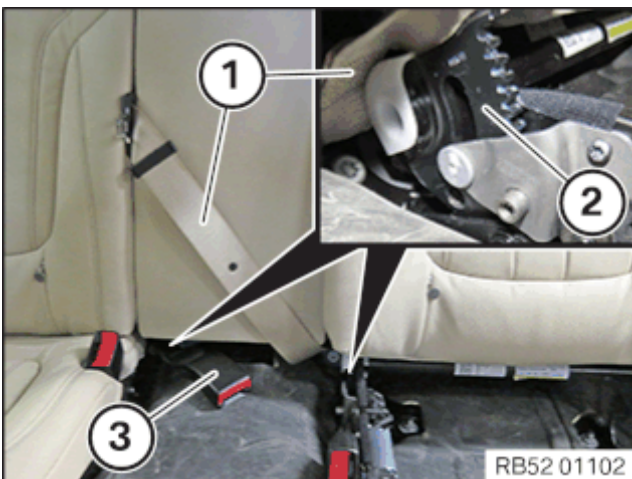

- Check seat belt (1) and lower strap (3).

Seat belt (1) and lower strap (3) must not be trapped by the seat mechanism (2).



- Equipment specification with active seat:

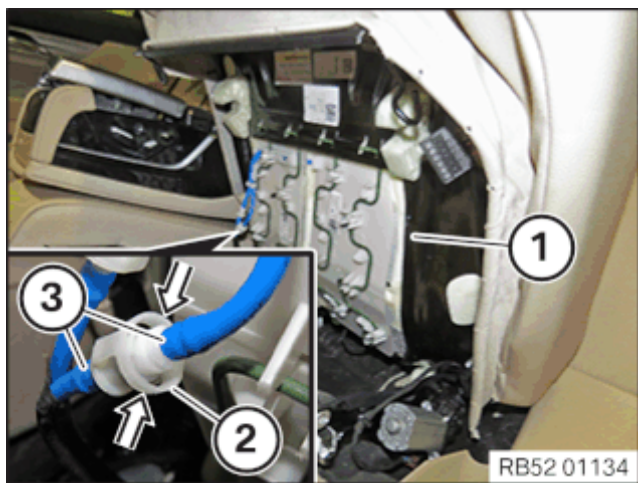

Position seat surface (1) as illustrated.

Coupling (2) must not be damaged.

Connect lines (3) together and ensure correct latch mechanism of the coupling (2).



- Connect all connectors with the seat surface.
- Attach wire spring clip (1), first inside (tunnel-side), into the fixture (2) of the seat mechanism.
- Then attach wire spring clip (1), outside (door-side), into the fixture (2) of the seat mechanism.
- Ensure correct fit of the wire spring clip (1) in the fixture (2).



- Guide seat belt buckle into seat surface.
- Clip in seat surface from above.



65 77 018 Replace airbag control unit

Overview of Activities

Additional Information

Preliminary Work

- 1 Disconnecting all battery earth leads
- 2 Removing the centre stack trim
- 3 Removing the front storage compartment
- 4 Removing the centre armrest storage compartm...
- 5 Removing the rear centre console trim
- 6 Removing the rear storage compartment
- 7 Removing the trim panel for pedal mechanism
- 8 Removing the bottom left instrument panel trim
- 9 Removing the centre console

Main Work

- 10 Removing the airbag control unit
- 11 Installing the airbag control unit

Postprocesses

- 12 Installing the centre console
- 13 Installing the botto right instrument panel trim
- 14 Installing the trim panel for the pedal mechanism
- 15 Installing the rear storage compartment
- 16 Installing the rear centre console trim
- 17 Installing the centre armrest storage compartment
- 18 Installing the front storage compartment
- 19 Installing the centre stack trim
- 20 Disconnecting all battery earth leads

General information

PRELIMINARY WORK

1-Disconnecting all battery earth leads

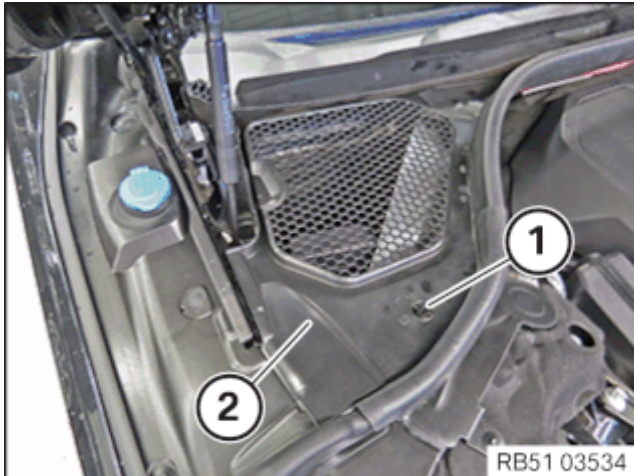

◀ Removing the rear right engine compartment cover

- Loosen the lock (1).
- Remove the cover (2).



◀ Disconnect battery earth lead (engine compartment)

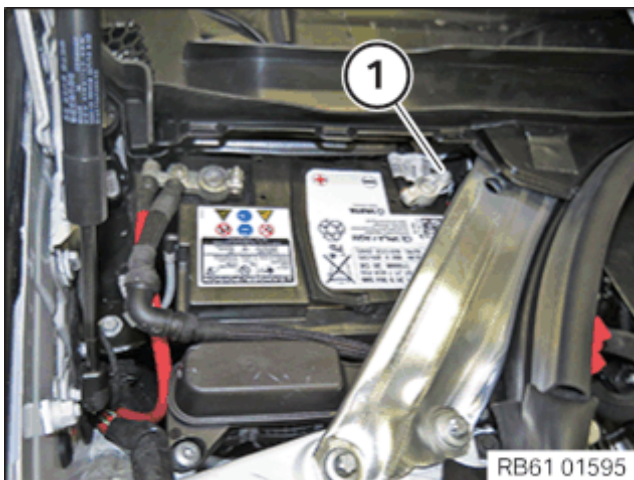

RISK OF DAMAGE

Damage to battery terminal, the safety battery terminal or the intelligent battery sensor (IBS).

Damaged battery terminals can lead to malfunctions or vehicle electrical system faults.

- Pull off battery terminal from battery pole by carefully moving to and fro. Do not pry off using a tool.

- Loosen the nut on the negative battery terminal (1).
- Pull off the negative battery terminal (1) from the negative battery terminal.
- Put the battery earth lead to one side and secure it.



◀ Removing the luggage compartment floor trim panel

- Lever out the luggage compartment floor trim panel (1) on the side using special tool **0 496 569 (00 9 325)**.

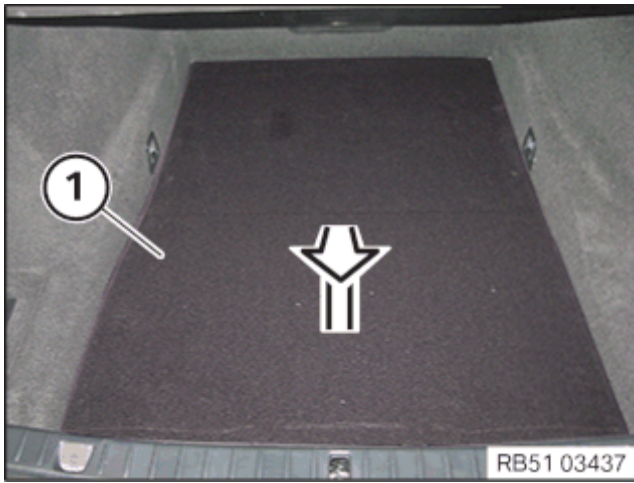

- Remove luggage compartment floor trim panel (1) in direction of arrow.



◀ Removing the storage tray



- Remove the storage tray (1) towards the top.



◀ Disconnecting the battery earth lead

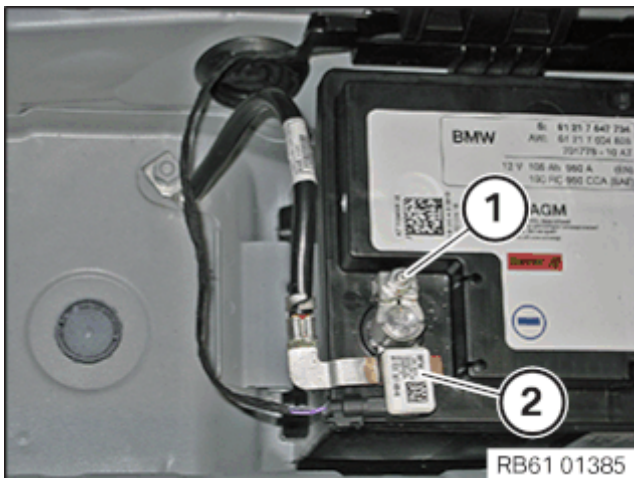

RISK OF DAMAGE

Damage to battery terminal, the safety battery terminal or the intelligent battery sensor (IBS).

Damaged battery terminals can lead to malfunctions or vehicle electrical system faults.

- Pull off battery terminal from battery pole by carefully moving to and fro. Do not pry off using a tool.

- Slacken nut (1).
- Pull off the negative battery terminal and the IBS (2) from the negative battery terminal.
- Put the battery earth lead to one side and secure it.



◀ Removing the storage tray for the compact spare wheel



- Loosen the Velcro fastener (1).
- Remove the compact spare wheel including insert (2) towards the top.



- Remove the storage tray (1) towards the top rear.



◀ Disconnect the battery earth lead (active steering)

i TECHNICAL INFORMATION

Disconnect and connect the battery at the battery terminals only. Do not disconnect at the connectors!

- Loosen the screw (1) and remove the battery holder.
- Push battery (2) as far to the right as possible.

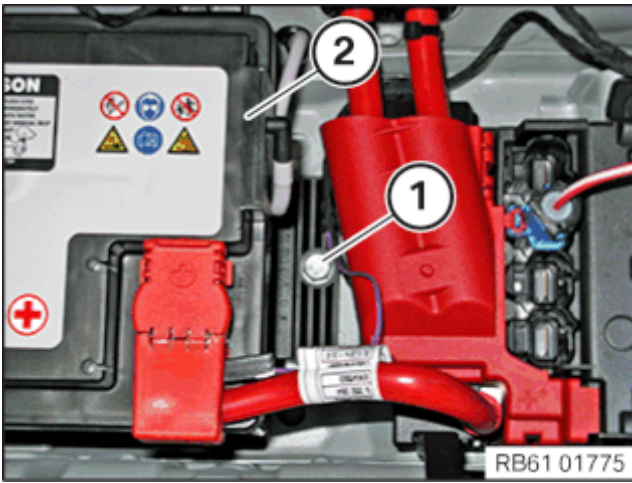

- Loosen screws (1).
- Remove the retaining brackets (2).
- Move auxiliary battery (3) and separating element (4) as far as possible to the right.

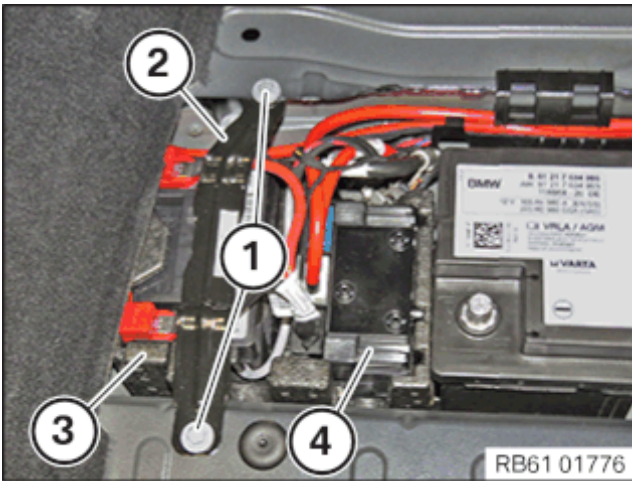

- Open the protective cap (1).
- Loosen the screw on the negative battery terminal (2).
- Put the battery earth lead to one side and secure it.

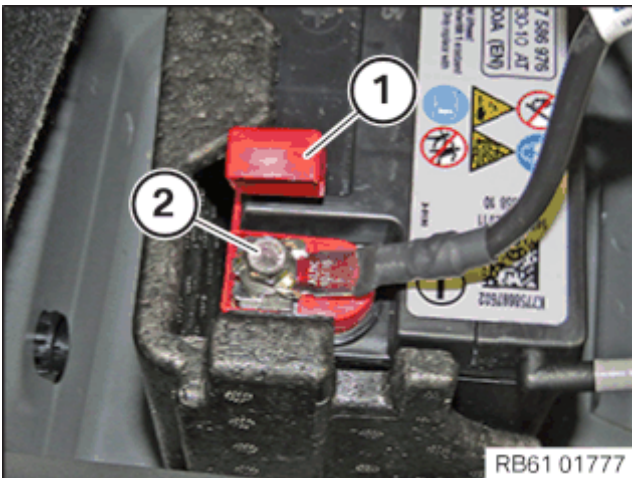

2-Removing the centre stack trim

- Unclip the centre stack trim (1) with the special tool **0 496 569 (00 9 325)** toward the bottom.

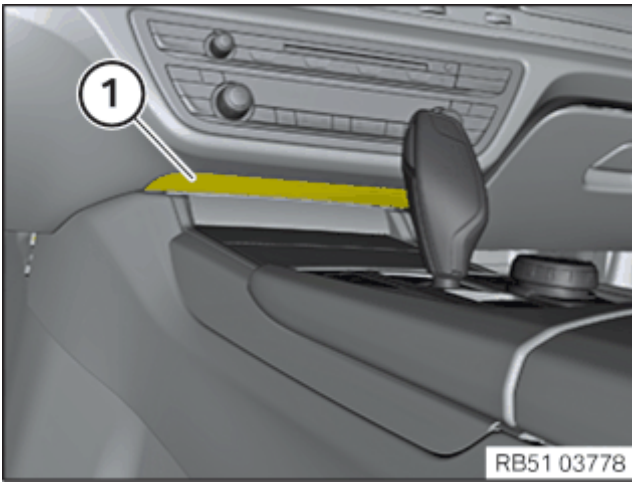

3–Removing the front storage compartment

Prerequisite

The cover of the storage compartment is open.

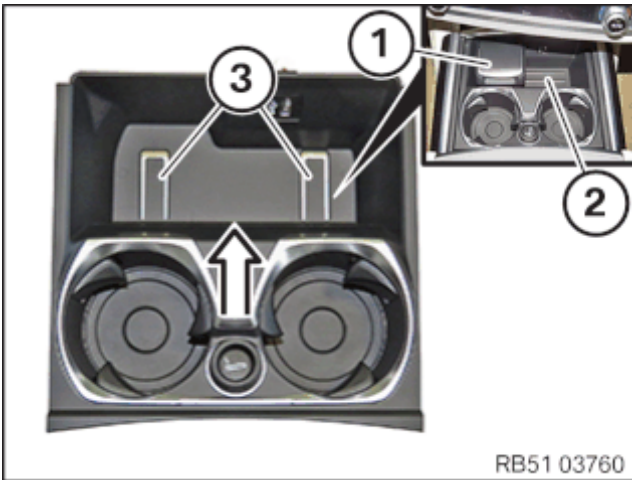

- If applicable, remove the insert (1).
- Remove the insert mat (2).
- Lift the latch mechanisms (3) and push the storage compartment towards the front.

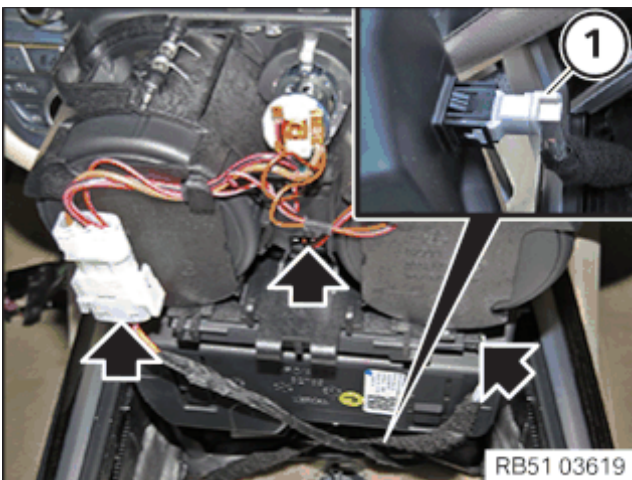

- Place the storage compartment in an upright position.
- Disconnect the connector for the USB port (1).
- Unlock and disconnect all connectors on the bottom of the storage compartment.
- Remove the storage compartment.

4–Removing the centre armrest storage compartment

Prerequisite

Centre armrest storage compartment is open.

- Remove the cover of the 12-V power socket (1).

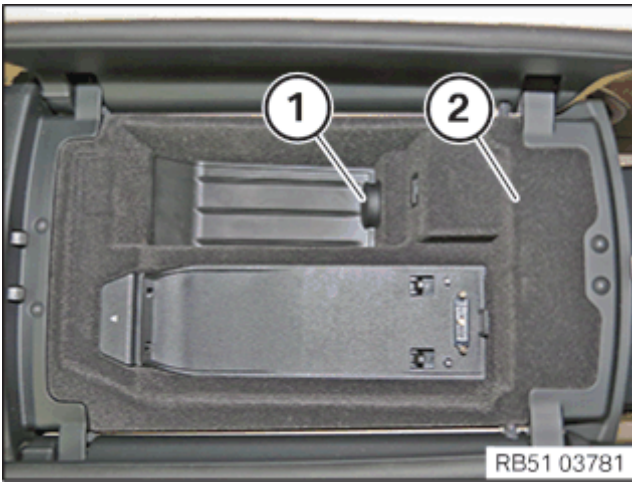

- Reach into the 12-V power socket. Pull the rear centre armrest storage compartment (2) upward and unclip.
- Unlock all plug connections and disconnect.
- Remove centre armrest storage compartment (2).

5-Removing the rear centre console trim



- Unclip rear centre console trim (1) with special tool **0 496 569 (00 9 325)** toward the back.
- Unlock all plug connections and disconnect.
- Remove rear centre console trim (1).

6-Removing the rear storage compartment

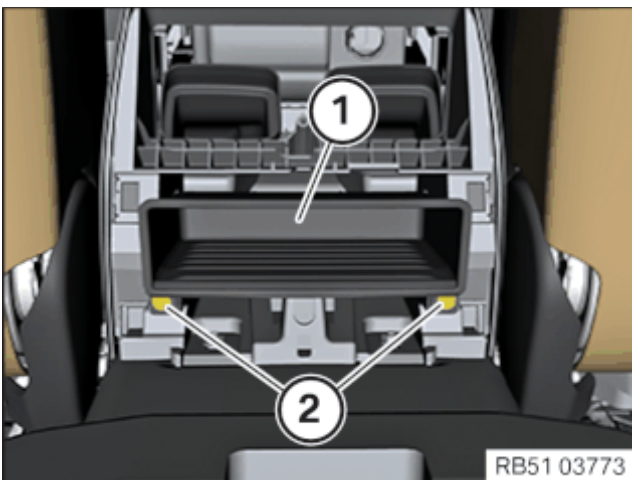

- Loosen screws (2).
- Pull rear storage compartment (1) to the rear.

7-Removing the trim panel for pedal mechanism

- Unclip the trim panel (1) towards the inside in this area (2).
- Twist the locks (3) by 90 degrees.
- Detach trim panel (1) inwards out of the guides (4).

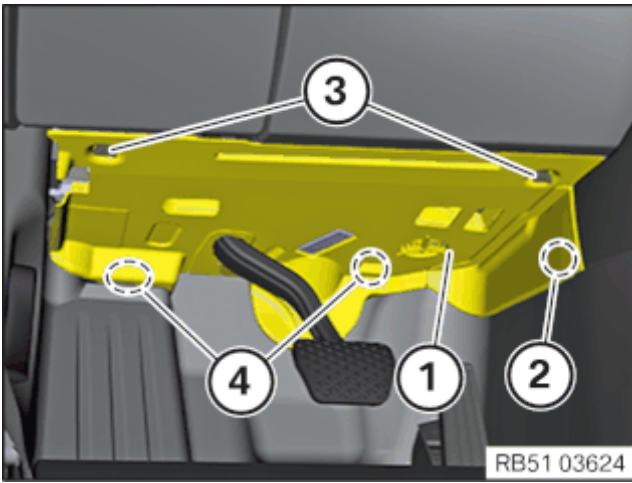

- Unlock associated plug connection and disconnect.

8–Removing the bottom left instrument panel trim

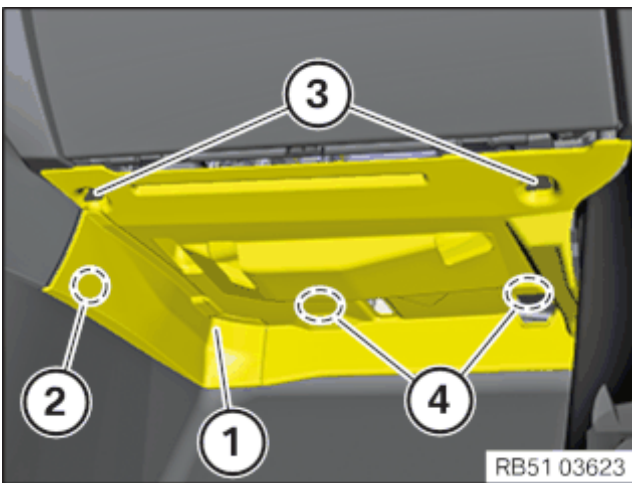

- Unclip the trim panel (1) towards the inside in this area (2).
- Twist the locks (3) by 90 degrees.
- Detach the trim panel (1) from the guides (4) towards the inside.
- Unlock associated plug connection and disconnect.

9–Removing the centre console

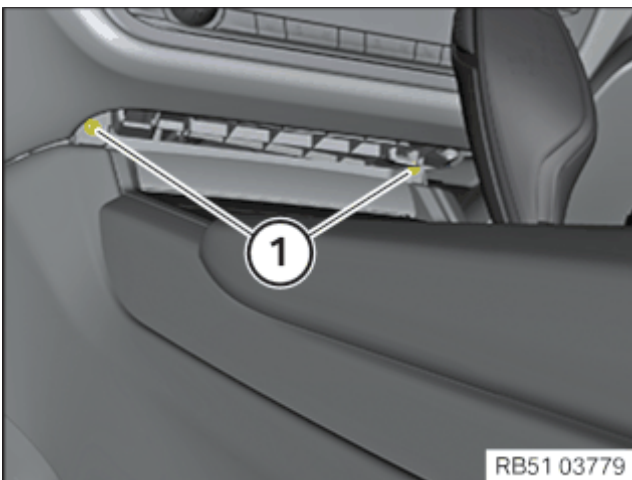

- Loosen screws (1).

- Loosen screws (1).

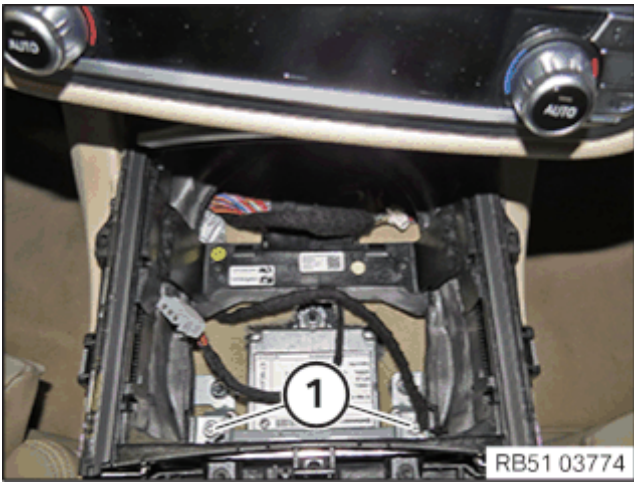

- Loosen screws (1).

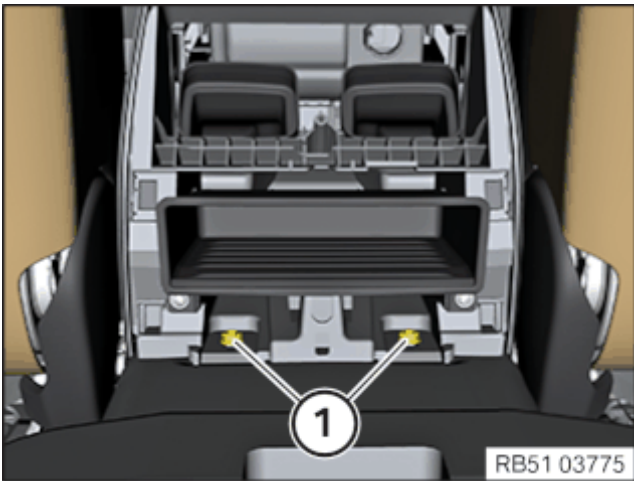

- On the left side of vehicle, loosen the screw (1).



- On the right side of vehicle, loosen the screws (1).

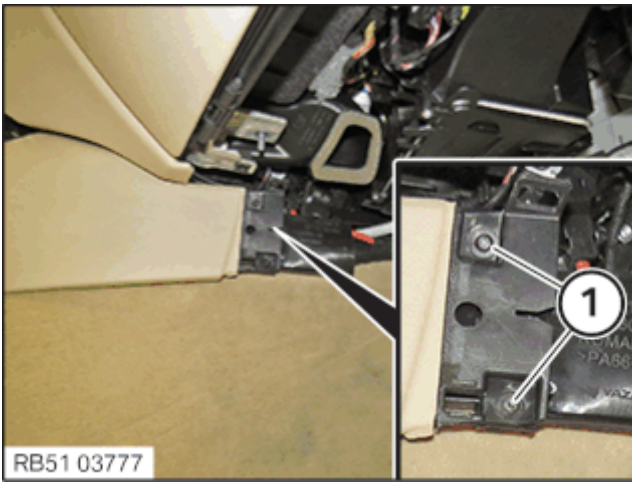

- Unlock and disconnect central connector (1).

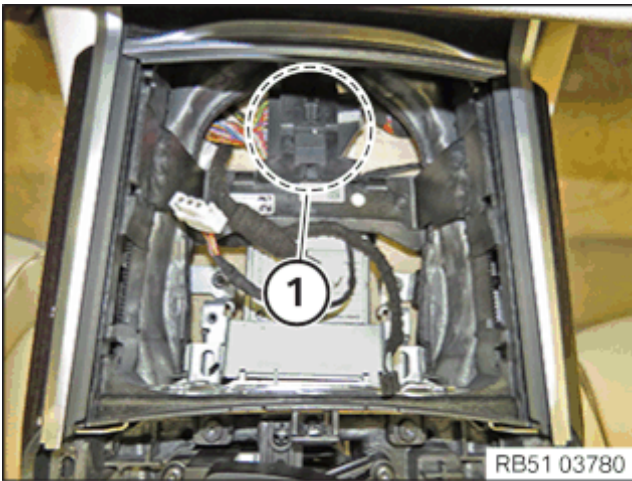

- Lift up centre console and pull to rear.
- Lift centre console out of vehicle.

MAIN WORK

10–Removing the airbag control unit

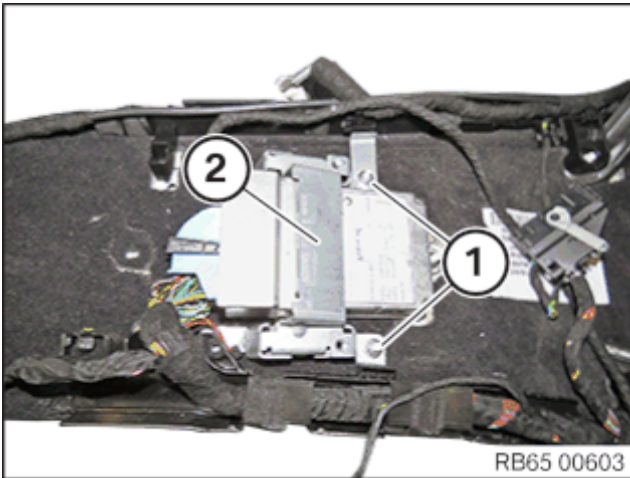

- Loosen nuts (1).
- Remove the holder (2).

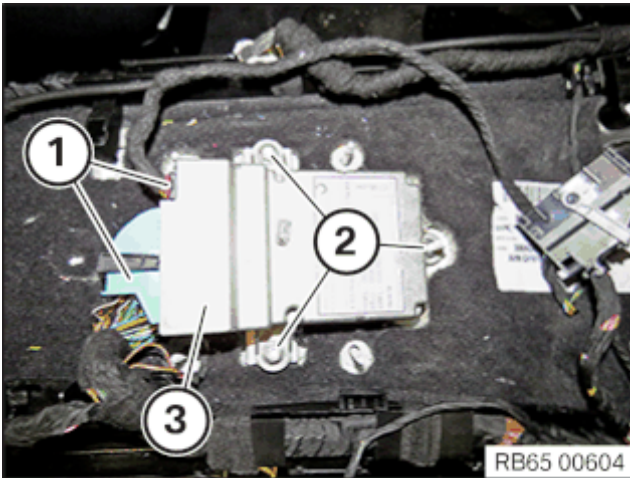

- Unlock and disconnect connector (1).
- Loosen nuts (2).
- Remove airbag control unit (3).

11–Installing the airbag control unit

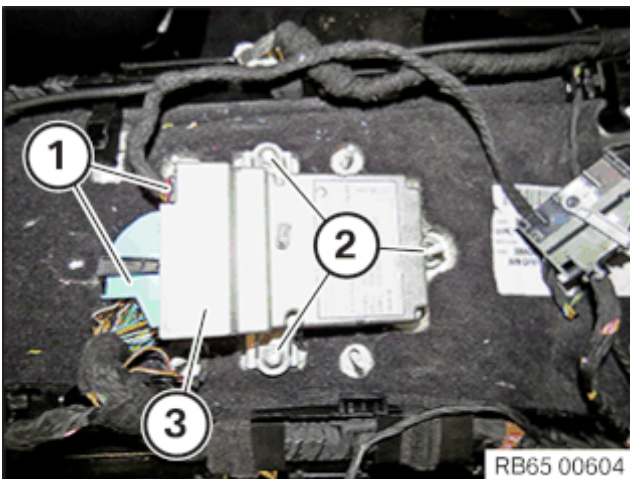

- Position airbag control unit (3) correctly.
- Tighten nuts (2).
- Connect connectors (1) and lock.

- Correctly position the holder (2).
- Tighten nuts (1).

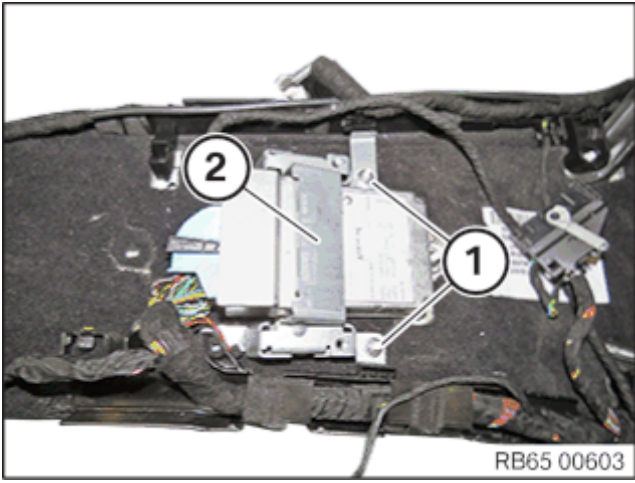

POSTPROCESSES

12–Installing the centre console

- Lift centre console into vehicle.
- Align centre console on Cardan tunnel and push from the front.

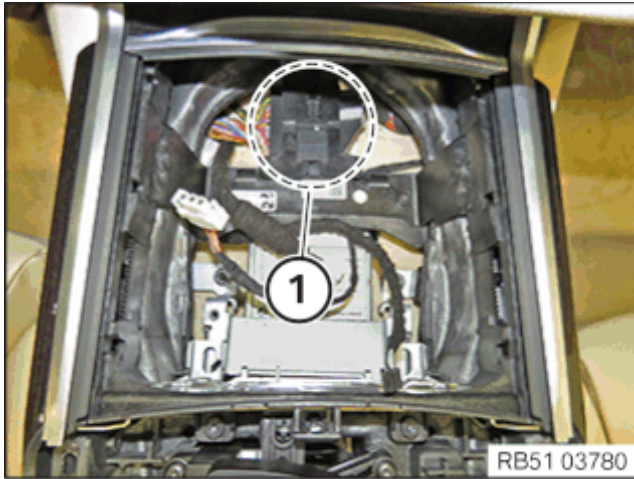

- Connect central connector (1).

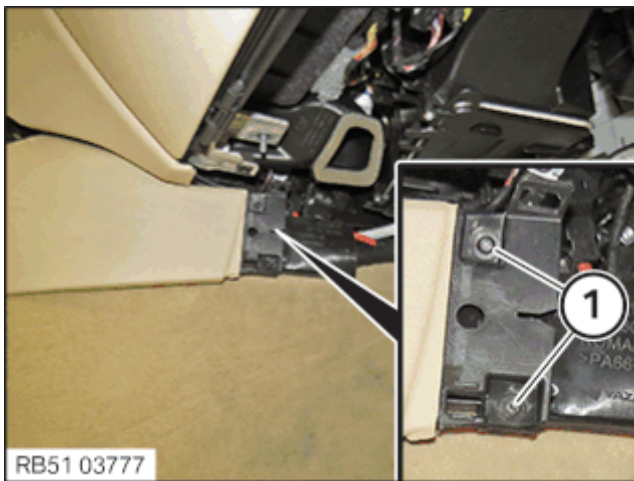

- On the right side of vehicle, tighten the screws (1).

Centre console



1,8 Nm



- On the left side of vehicle, tighten the screw (1).

Centre console



1,8 Nm

- Tighten the screws (1).

Centre console to holder



4,6 Nm

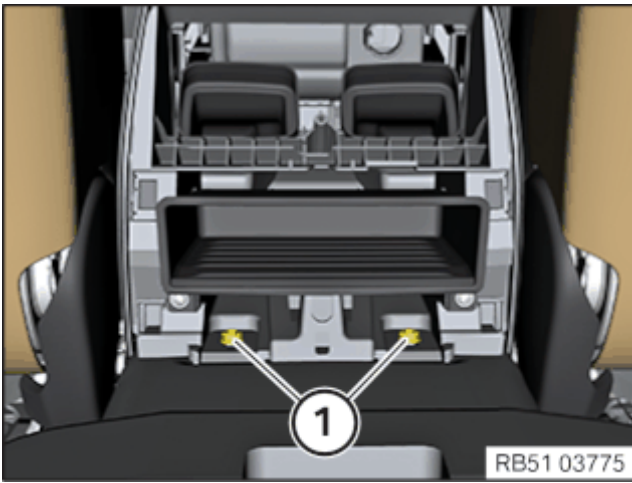

- Tighten the screws (1).

Centre console to holder



	4,6 Nm
--	--------

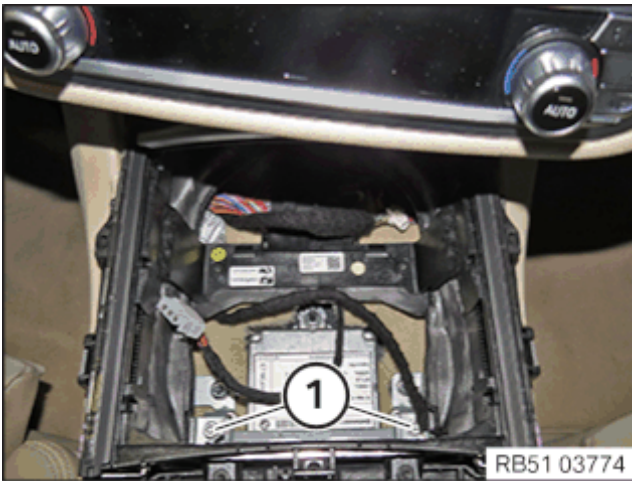

- Tighten the screws (1).

Centre console to instrument panel



	2,3 Nm
--	--------

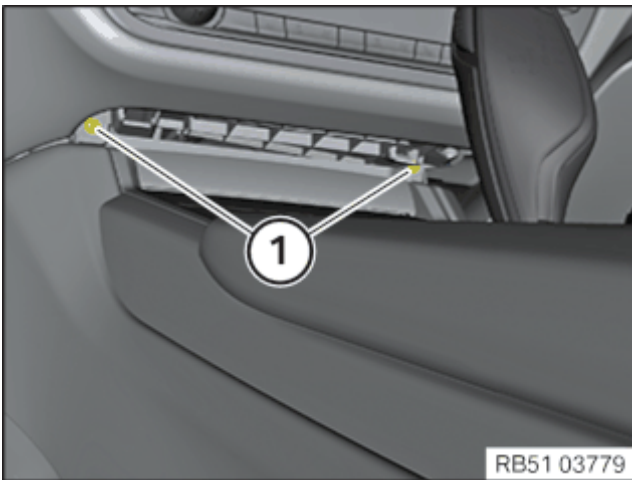

13–Installing the botto right instrument panel trim

- Connect associated connector.
- Attach the trim panel (1) to the guides (4) and fold towards the top.
- Clip the trim panel (1) into the centre console in this area (2).
- Correctly insert the locks (3) and twist by 90 degrees.

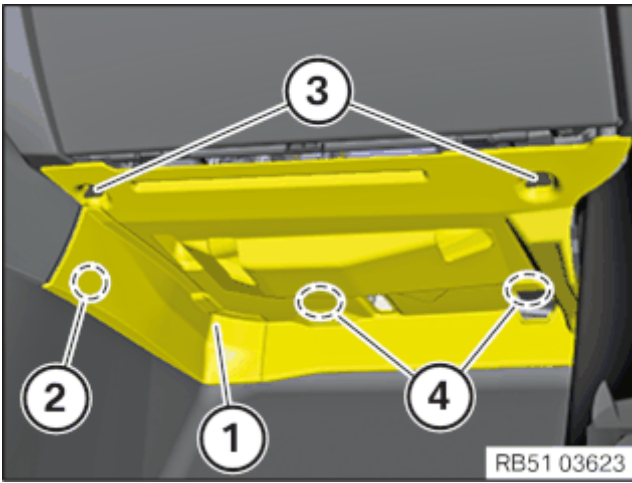

14–Installing the trim panel for the pedal mechanism

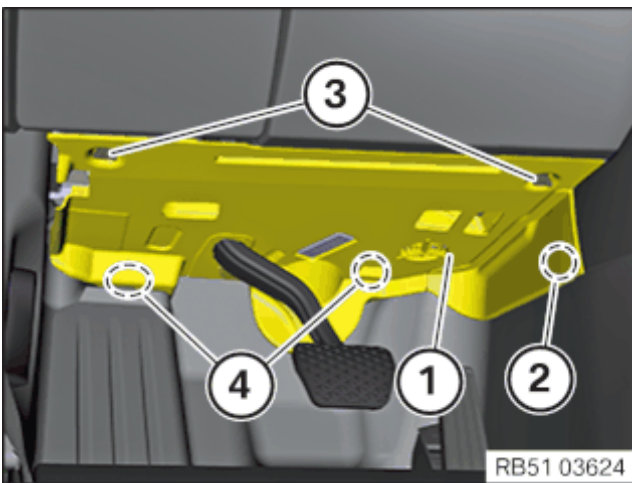

- Connect associated connector.
- Attach the trim panel (1) to the guides (4) and fold towards the top.
- Clip the trim panel (1) into the centre console in this area (2).
- Correctly insert the locks (3) and twist by 90 degrees.

15–Installing the rear storage compartment

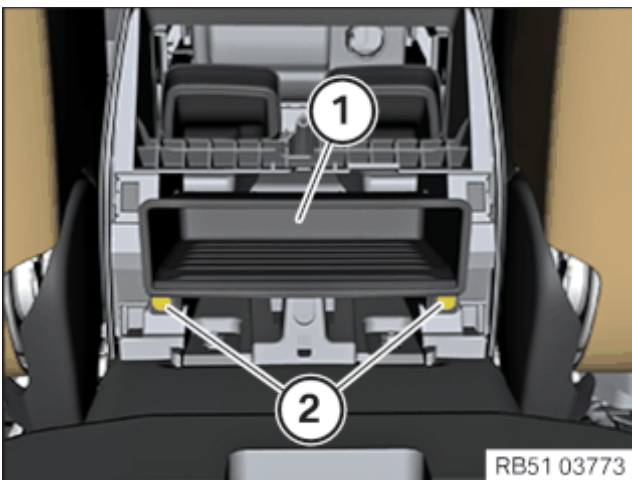

- Insert rear storage compartment (1) into centre console.
- Tighten down screws (2).

Rear storage compartment to centre console



2,3 Nm

16–Installing the rear centre console trim

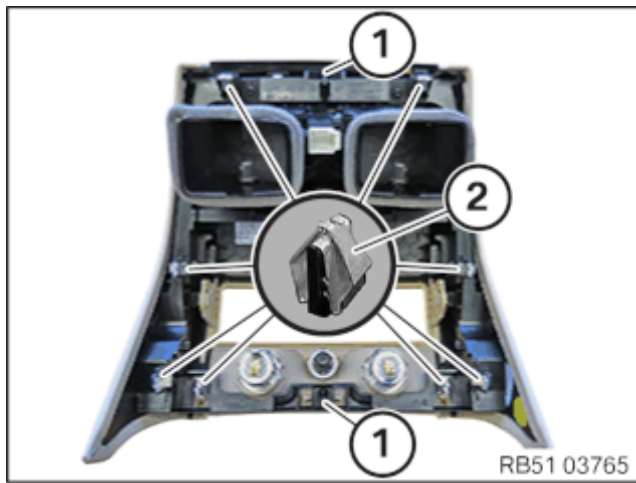

i TECHNICAL INFORMATION

Latch mechanisms, guides and mounting elements must not be damaged or missing.

- Check guides (1) and clamps (2); replace if necessary.



- Connect all plug connections.
- Clip in rear centre console trim (1) in a forwards direction.

17–Installing the centre armrest storage compartment

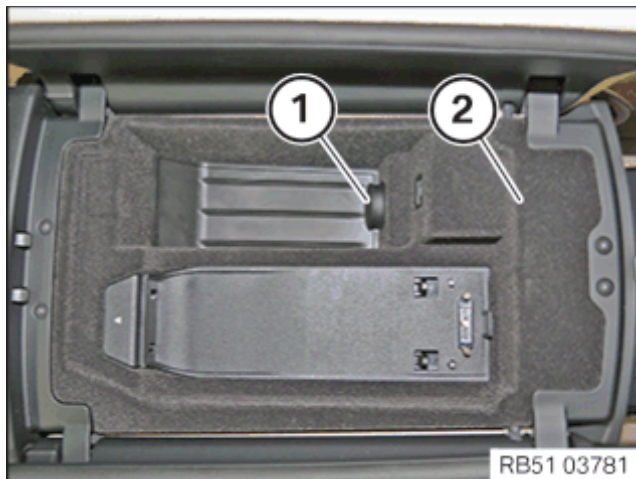

i TECHNICAL INFORMATION

Latch mechanisms, guides and mounting elements must not be damaged or missing.

- Check the latch mechanisms and guides on the centre armrest storage compartment (2).
- Position the centre armrest storage compartment (2) on the centre armrest.
- Connect all plug connections.
- Insert the centre armrest storage compartment (2) at the front and press down.

18–Installing the front storage compartment

- Align the storage compartment with the centre console when it is in upright position.
- Connect the connector for the USB port (1).
- Connect all connectors on the bottom of the storage compartment.

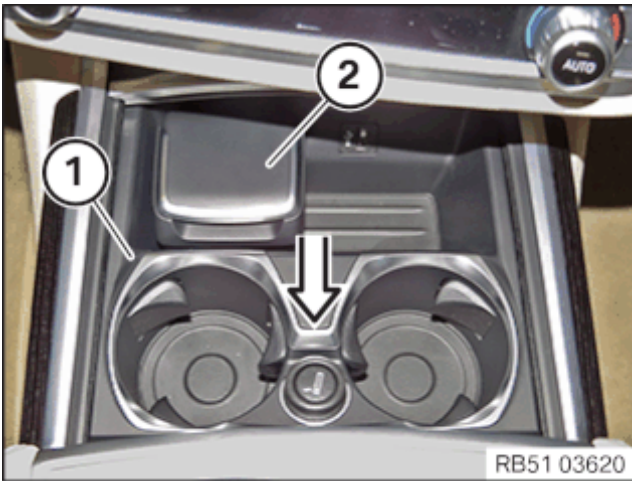
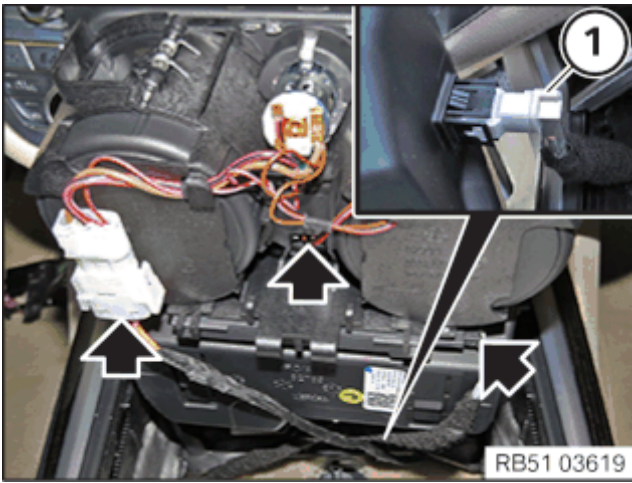

- Insert the storage compartment (1) in the centre console.
- Forcefully pull the storage compartment (1) backwards and engage it.
- Insert the insert mat.
- If applicable insert the insert (2).

19–Installing the centre stack trim

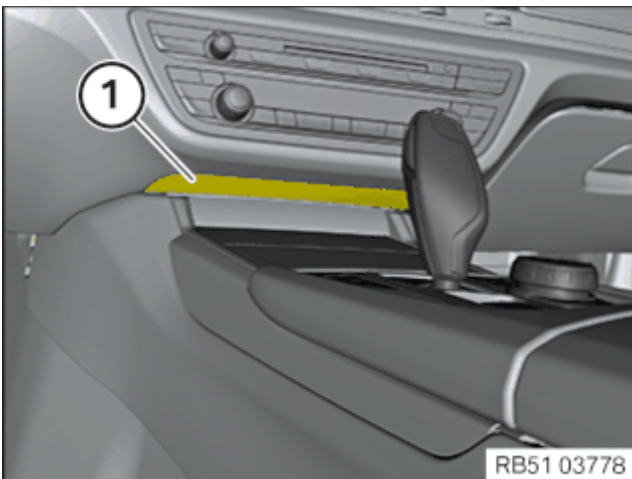

i TECHNICAL INFORMATION

Latch mechanisms, guides and mounting elements must not be damaged or missing.

- Check latch mechanisms and guides on centre stack trim (1).
- Clip in centre stack trim (1) in upward direction.

20–Disconnecting all battery earth leads

◀ Connecting the battery earth lead (active steering)

i TECHNICAL INFORMATION

Disconnect and connect the battery at the battery terminals only. Do not disconnect at the connectors!

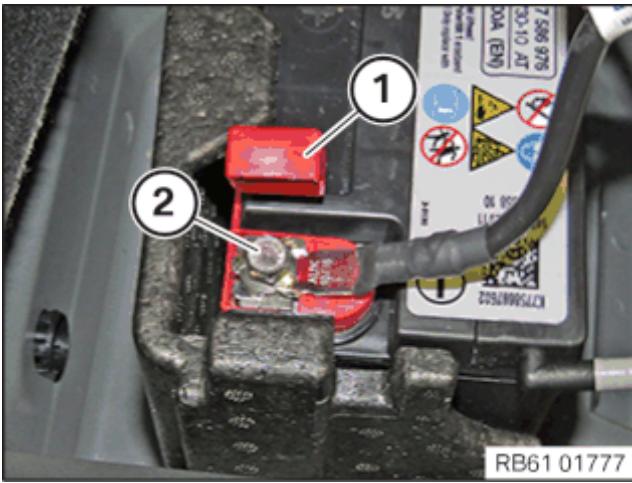

- Tighten the negative battery terminal using the screw (2).
- Close the protective cap (1).

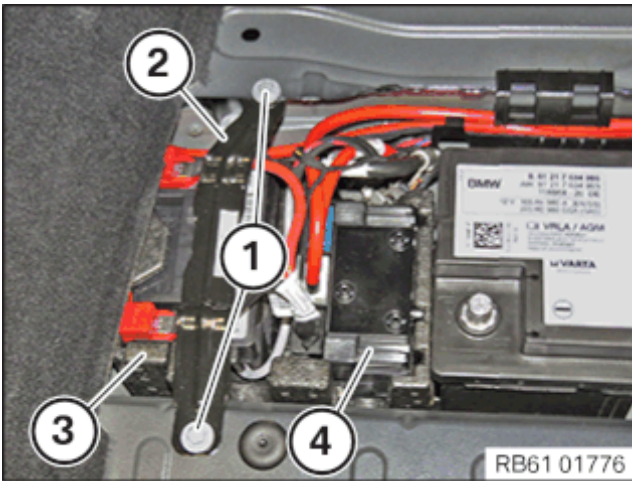

- Push battery (3) and separating element (4) back to the left.
- Insert the retaining bracket (2).
- Tighten the screws (1).

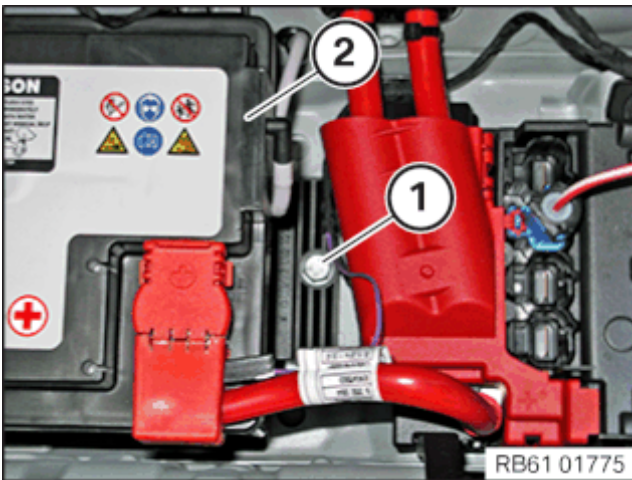

- Move the battery (2) back towards the left again.
- Attach the battery holder and tighten using the screw (1).

Battery holder to body



M8x40 screw		10 Nm
-------------	--	-------



◀ Installing the compact spare wheel storage tray

- Insert the storage tray (1).



- Insert the compact spare wheel with insert (2).
- Close the Velcro fastener (1).

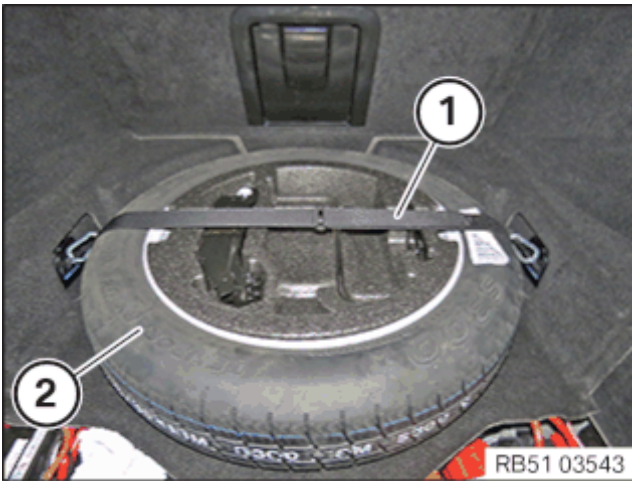

◀ Installing the storage tray

- Insert the storage tray (1) towards the bottom.



◀ Installing the luggage compartment floor trim panel

- Insert the luggage compartment floor trim panel (1) in the direction of the arrow.

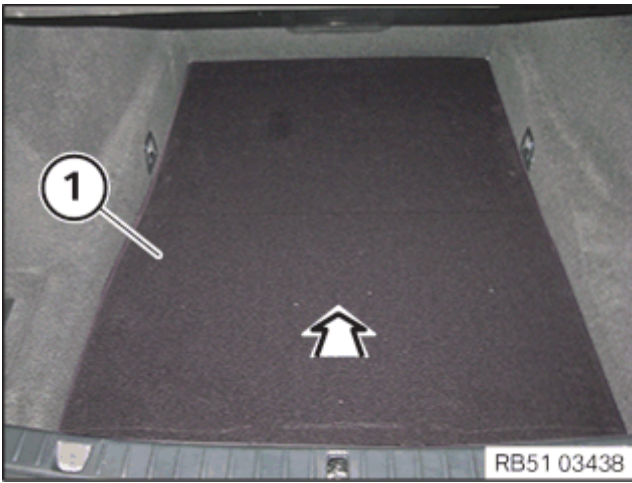

◀ Installing the rear right engine compartment cover

- Install the cover (2).
- Lock the lock (1).

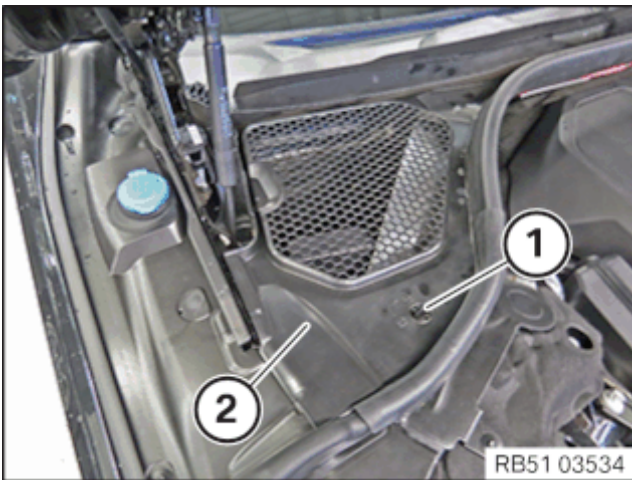

21–Encode/program control unit(s)

i TECHNICAL INFORMATION

Use the most recent software version to prevent faults during programming/encoding.

The battery voltage must not fall below 13.0 V during programming.

Use only chargers for a low volt-vehicle electrical system that are recommended by BMW.

i TECHNICAL INFORMATION

No high-voltage switch off is required in electric vehicles or hybrid vehicles for programming/encoding.

The high-voltage system will be automatically switched off by the programming system.

- Connect the battery charger to the vehicle.
- Connect the programming system with the vehicle.

- Determine the action plan.
- Accept and fully process the measures plan.
- If applicable, connect the workshop system to the vehicle, depending on the reworking list.
- Carry out vehicle test.
- Delete the fault memory.
- The information about programming the workshop system and the corresponding notes in the user documentation must be observed.
- Wait until programming/encoding has been completed.
- Disconnect the programming system from the vehicle.
- Disconnect the battery charger from the vehicle.

Removal of the Back of the Center Console – Step 5 REP 6577018



Unlocking the ACSM Large Electrical Connection – Step 10 REP 6577018

B65 11 16

1

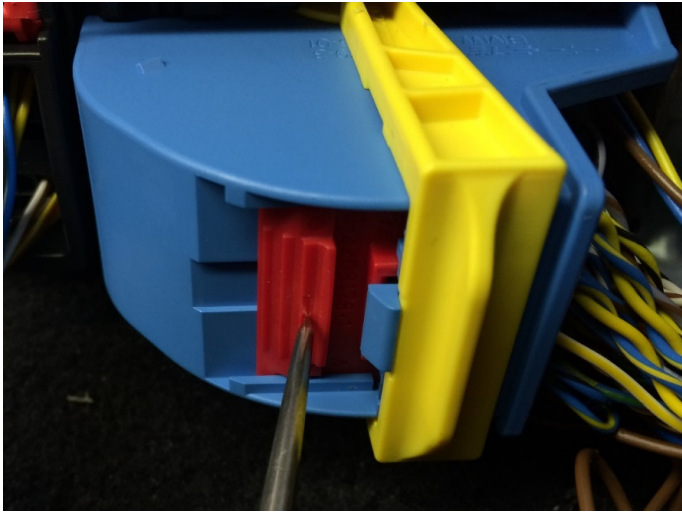

2

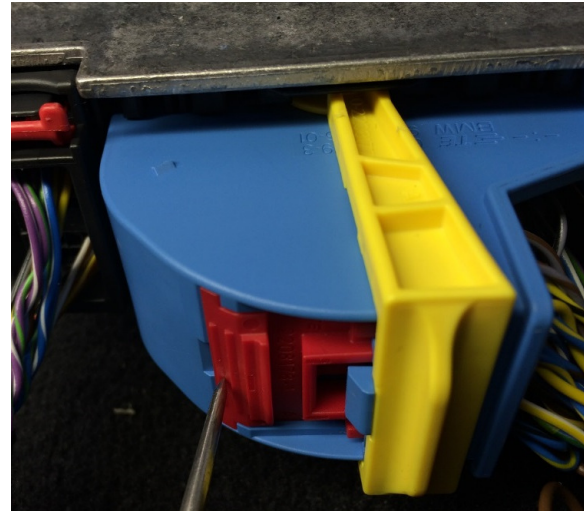

3

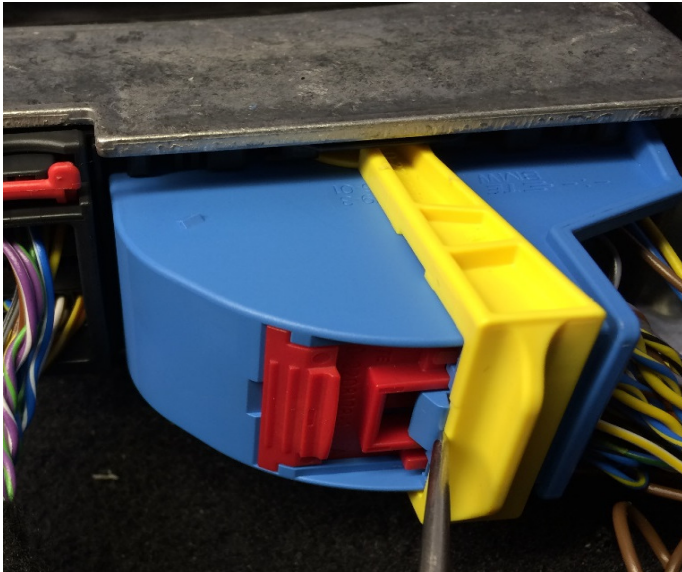

4

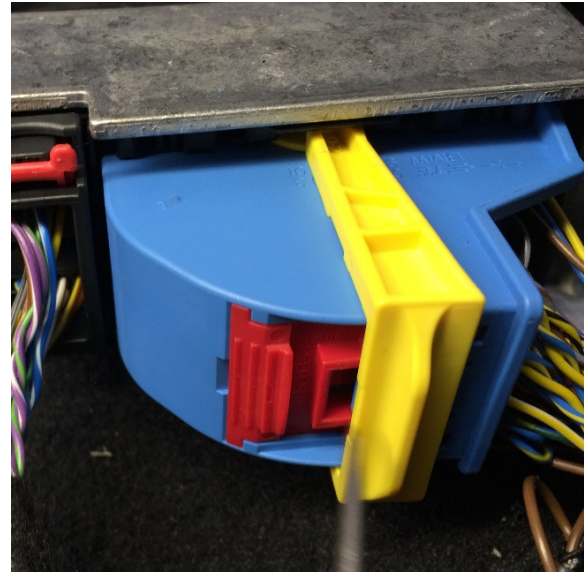

Unlocking the ACSM Small Electrical Connection – Step 10 REP 6577018

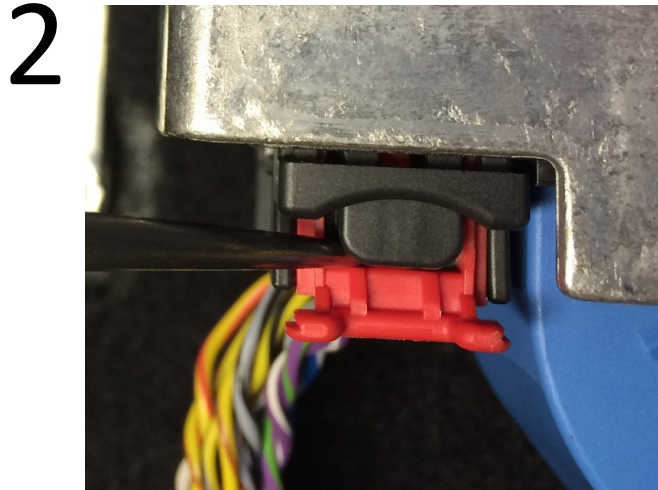
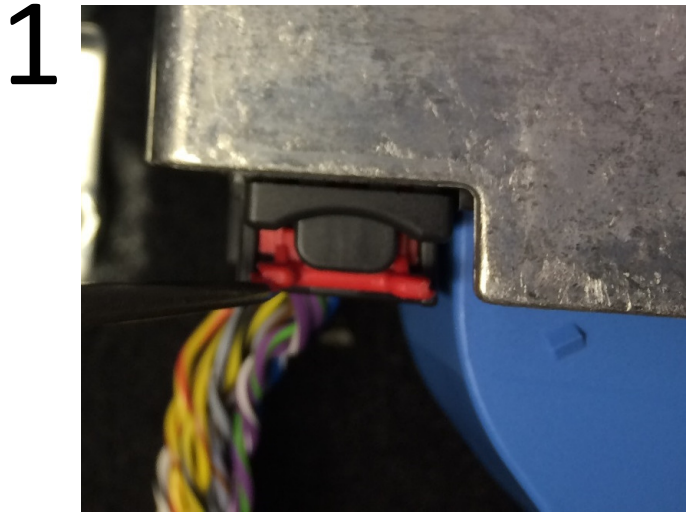

ACSM 4 Mounting Nuts – Step 10 REP 6577018

1

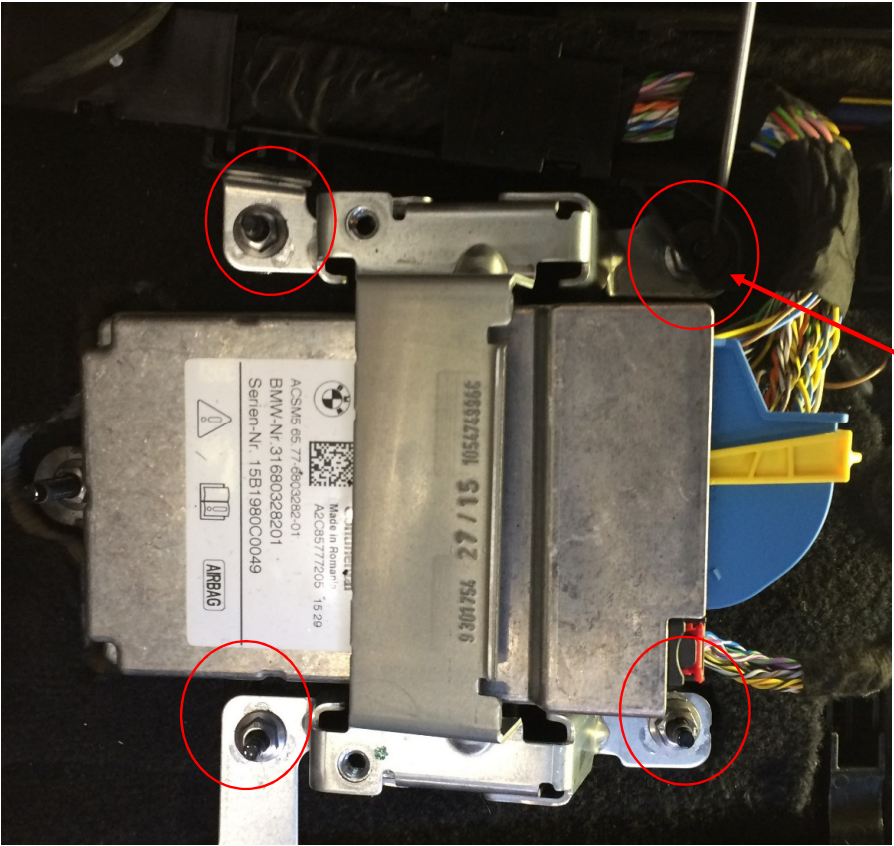

2

