

ATTENTION:

- GENERAL MANAGER
- PARTS MANAGER
- CLAIMS PERSONNEL
- SERVICE MANAGER

IMPORTANT - All Service Personnel Should Read and Initial in the boxes provided, right.

| | | |
|--|--|--|
| | | |
| | | |



QUALITY DRIVEN® SERVICE

© 2016 Subaru of America, Inc. All rights reserved.

PRODUCT CAMPAIGN BULLETIN

APPLICABILITY: 2015-2016 MY Forester 2.0XT
 2015-2016 MY WRX 2.0 DIT
SUBJECT: Turbocharger Air Intake Duct

NUMBER: WTA-62
DATE: April 4, 2016
NHTSA ID: 16V162

INTRODUCTION

Subaru of America, Inc. (Subaru) is initiating a Recall Campaign for certain 2015-16 model year Forester 2.0XT and WRX vehicles. Subaru has determined that vehicles affected by this Recall Campaign require inspection and possible replacement of the turbocharger air intake duct.

DESCRIPTION OF THE SAFETY DEFECT & SAFETY HAZARD

The turbocharger air intake duct on affected vehicles may have been produced with incorrect material that is susceptible to cracking. Should the turbocharger air intake duct crack, the engine may develop an abnormally rough idle, lower power and possibly stall. Should the engine suddenly lose power or stall while driving, there is an increased risk of a crash.

In addition, this condition may cause the “Check Engine” light located on the instrument panel to illuminate, indicating a malfunction has occurred. It could also have an adverse effect on vehicle exhaust emissions.

DESCRIPTION OF THE REMEDY

The repair procedure will involve inspecting and possibly replacing the turbocharger air intake duct. Inspection of the turbocharger air intake duct lot number (date) molded on the duct will be necessary to determine if replacement is required.

AFFECTED VEHICLES

- Certain 2015-2016 model year Forester 2.0XT vehicles
- Certain 2015-2016 model year WRX vehicles

Not all vehicles listed below are covered by this campaign. Coverage for all affected vehicles must be confirmed by using the Vehicle Coverage Inquiry function on subarunet.com.

| VEHICLE MODEL | | AFFECTED VIN RANGE |
|----------------|------|---------------------------|
| Forester 2.0XT | 2015 | From FH819330 to FH842199 |
| | 2016 | From GH400090 to GH475644 |
| WRX | 2015 | From F*838026 to F*838040 |
| | 2016 | From G*800045 to G*820448 |

Continued...

| | |
|-----------------------------------------------------------------------------------------------------------------------------------------------------------------------------------------------------------------------------------------------------------------------------------------------------------------------------------------------------------------------------------------------------------------------------------------------------------------------------------------------------------------------------------------------------------------------------------------------------------------------------------------------------------------------------------|-------------------------------------------------------------------------------------------------------------------------------------------------------------------------------------------------------------------------------------------------------------------------------------------------------------------------------------------------------------|
| <p>CAUTION: VEHICLE SERVICING PERFORMED BY UNTRAINED PERSONS COULD RESULT IN SERIOUS INJURY TO THOSE PERSONS OR TO OTHERS. Subaru Service Bulletins are intended for use by professional technicians ONLY. They are written to inform those technicians of conditions that may occur in some vehicles, or to provide information that could assist in the proper servicing of the vehicle. Properly trained technicians have the equipment, tools, safety instructions, and know-how to do the job correctly and safely. If a condition is described, DO NOT assume that this Service Bulletin applies to your vehicle, or that your vehicle will have that condition.</p> | <p style="text-align: center;">SUBARU OF AMERICA, INC. IS “ISO 14001 COMPLIANT”</p> <p>The international standard for excellence in Environmental Management Systems. Please recycle or dispose of automotive products in a manner that is friendly to our environment and in accordance with all local, state and federal laws and regulations.</p> |
|-----------------------------------------------------------------------------------------------------------------------------------------------------------------------------------------------------------------------------------------------------------------------------------------------------------------------------------------------------------------------------------------------------------------------------------------------------------------------------------------------------------------------------------------------------------------------------------------------------------------------------------------------------------------------------------|-------------------------------------------------------------------------------------------------------------------------------------------------------------------------------------------------------------------------------------------------------------------------------------------------------------------------------------------------------------|

OWNER NOTIFICATION

Notification letters will be sent by first class mail to owners of all potentially affected vehicles in April, 2016. A copy of the letter is included at the end of this bulletin.

RETAILER AFFECTED VIN LISTS

Each Subaru retailer will receive an affected VIN list from their Zone office when owner notification begins. Vehicles will be assigned to retailers in the affected VIN list as follows:

- Original vehicle owners are assigned to the original selling retailer when their current address is within a 100-mile radius of that retailer.
- If the original selling retailer is inactive, the VIN has been assigned to the nearest active retailer.
- For any new owners or when original owners live more than 100 miles from the original selling retailer, the VIN has been assigned to the nearest active retailer.

IMPORTANT: Retailer affected VIN lists include owner name and address information for vehicles affected by this recall. This information will enable retailers to follow-up with owners of potentially affected vehicles. The lists contain owners' names and addresses obtained from State Motor Vehicle Registration Records. The use of such motor vehicle registration data for any other purpose is unlawful. Accordingly, retailers are urged to limit the use of these lists for the purpose of completion of this safety recall.

SUBARU RETAILER PROGRAM RESPONSIBILITY

Retailers are to promptly perform the applicable service procedures to correct all affected vehicles in their inventory. Additionally, whenever a vehicle subject to this recall campaign is taken into inventory or in for service, necessary steps should be taken to ensure the service program has been performed before selling or releasing the vehicle.

Any vehicles listed in a recall campaign that are in the retailer's stock must be:

- Immediately identified.
- Tagged or otherwise marked to prevent their delivery or use prior to inspection and/or repair.
- Repaired in accordance with the repair procedures outlined in this Product Campaign Bulletin.

PARTS INFORMATION

NOT ALL VEHICLES WILL REQUIRE PARTS REPLACEMENT.

Only turbocharger air intake ducts with a lot number (date) of April (Month 4), 2015 require replacement. If the lot number (date) is confirmed to be April (Month 4), 2015 the part numbers listed below need to be replaced:

| DESCRIPTION | PART NUMBER | Quantity |
|--------------------------|-------------|----------|
| Duct – Air Intake | 14462AA571 | 1 |
| Gasket – Air Intake Duct | 14497AA040 | 1 |
| O Ring – Air Bypass | 21867AA000 | 1 |

SERVICE PROCEDURE / INFORMATION:

This repair procedure involves inspection of the lot number (date) molded into the duct. If the specified lot number (date) is found, the duct must be replaced. If other than the lot number (date) specified, the duct was manufactured using the correct material and replacement is not necessary.

All Turbocharger Intake ducts identified as having a lot number (date) of **April, 2015 must be replaced.**

Continued...

- Turn the ignition off and disconnect the battery from the battery sensor on the ground or **negative (-) terminal first**.

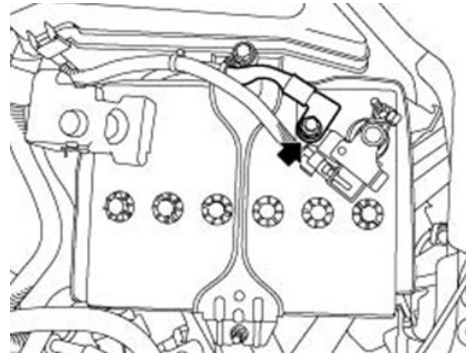

- Raise the vehicle and remove the bolts and clips securing the plastic under cover (1) following the procedure in the applicable Service Manual in order to gain access to the turbocharger air intake duct.

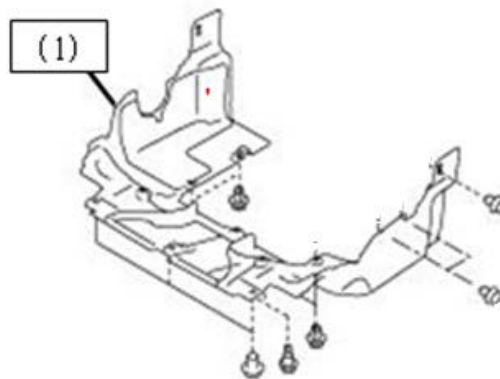

- Inspect the lot number (date) of the turbocharger air intake duct as shown below.

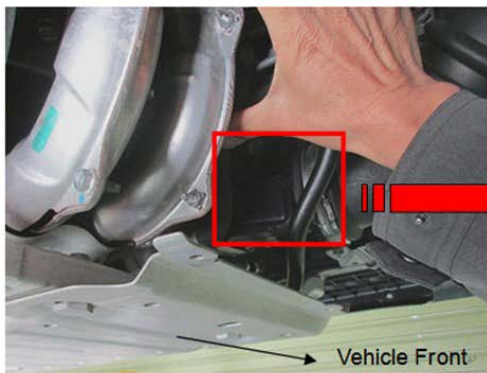

NOTE: Do not confuse this lot number (date) with the lot number (date) visible from the front of the vehicle.

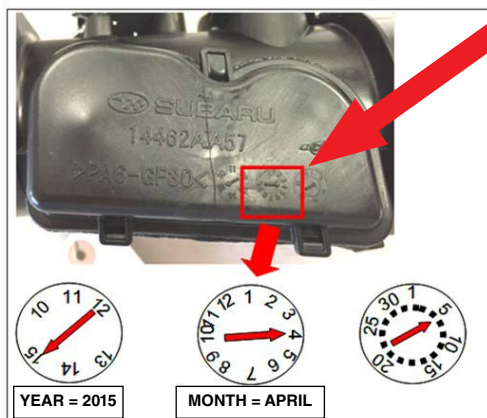

Continued...

IMPORTANT: Only turbocharger air intake ducts with a lot number (date) of **APRIL** (Month 4), 2015 require replacement. If the duct requires replacement based upon the date code, proceed to Replacement Procedure section. If the lot number (date) is confirmed to be **OTHER THAN APRIL, 2015** (Month 4), the turbocharger air intake duct does **NOT** need to be replaced. Continue on to undercover reinstallation.

- Reinstall the undercover following the procedure in the applicable Service Manual.

CAUTION: Make sure the front edge of the under cover (b) fits inside the bumper cover (a) as shown in the illustrations below.

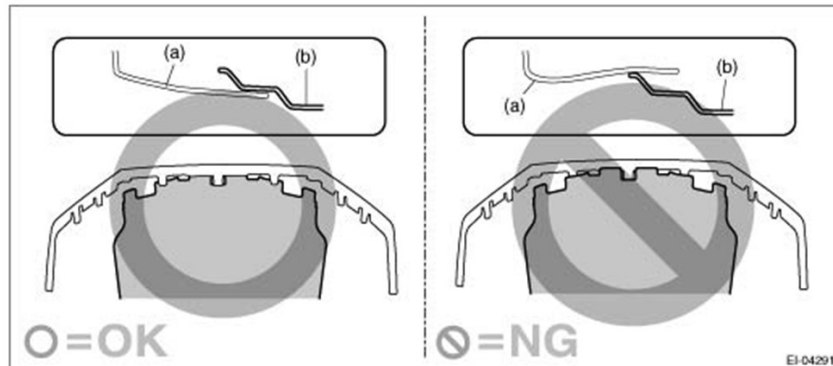

- Clean the battery cable terminals and apply grease to prevent corrosion.
- Reconnect the battery, positive (+) terminal first.
- Reconnect the negative (-) cable while holding the battery sensor to prevent it from rotating on the battery post. Torque the 12mm nut to 7.35 Nm (5.5 ft. lbs.).
- **IMPORTANT:** Wait at least 10 seconds after reconnecting the battery ground terminal before switching the ignition on to allow initial diagnosis of the electric throttle control. This will prevent setting DTCs. After switching the ignition on, **wait another 10 seconds** before starting the engine.
- If duct replacement is NOT required, stop here.

INTAKE DUCT REPLACEMENT PROCEDURE (WHERE APPLICABLE)

VERY IMPORTANT: If the lot number production date code is confirmed to be **APRIL** (Month 4), 2015 the turbocharger air intake duct **must be replaced** following the repair procedure outlined below.

- Disconnect the wiring harness connector from the waste gate control solenoid valve.

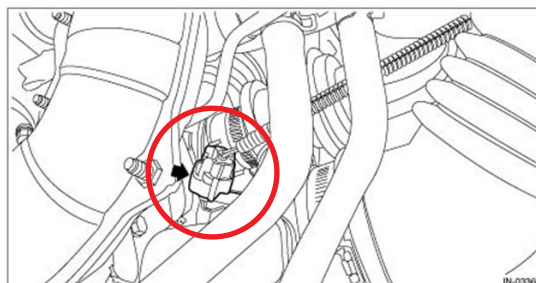

Continued...

- Disconnect the PCV hose (A) and the vacuum hose (C) from the turbocharger air intake duct and remove the vacuum hose (B) from the waste gate control solenoid valve.

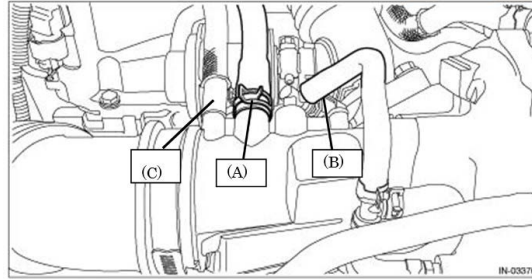

- Remove the hose clamp and the rubber intake boot from the turbocharger air intake duct. Disengage the spring clamp securing the by-pass valve to the turbocharger air intake duct as shown below.

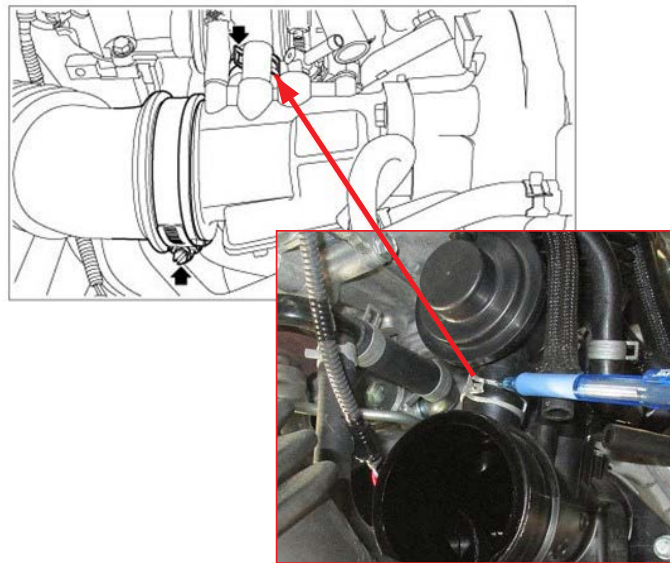

- Remove the 2 bolts securing the air intake duct to the turbocharger and remove it.

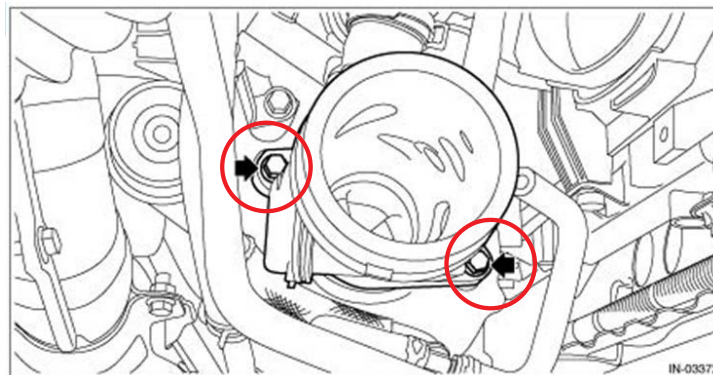

VERY IMPORTANT: Inspect the removed air intake duct closely for any cracking or damage. If the inspection shows the duct is cracked or has any pieces missing, the turbocharger impeller should be inspected closely for possible damage. If impeller damage is confirmed, the turbocharger assembly must also be replaced.

Continued...

- Transfer the waste gate control solenoid valve over to the new turbocharger air intake duct. **NOTE:** Always use a new o-ring. Make sure the waste gate control solenoid valve is fully seated into the new turbocharger air intake duct then torque the 2 retaining screws to 25 inch-pounds.

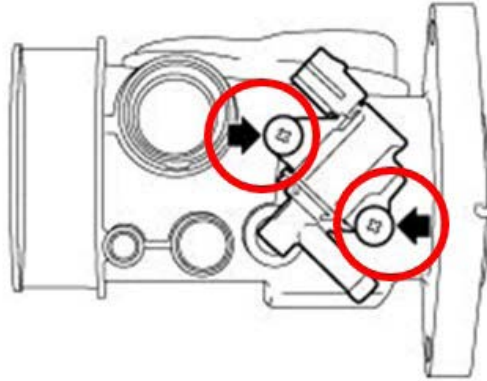

- Reinstall the new turbocharger air intake duct. Tighten the 2 retaining bolts to:
 - **4.7 ft. lbs. (57 inch-pounds) for 2015MY vehicles**
 - **5.5 ft. lbs. (66 inch-pounds) for 2016MY vehicles.**

IMPORTANT: Always use a new o-ring and be careful not to pinch it during installation.

- Reinstall the air by-pass valve to the new turbocharger air intake duct making sure it is fully inserted and refit the spring clamp.
- Refit the rubber intake boot to the new turbocharger air intake duct. Confirm the boot is properly seated. Reinstall the hose clamp and torque to 1.8 ft. lbs. (22 inch-pounds).
- Reconnect the PCV hose (A) and the vacuum hose (C) to the turbocharger air intake duct and the vacuum hose (B) to the waste gate control solenoid valve.

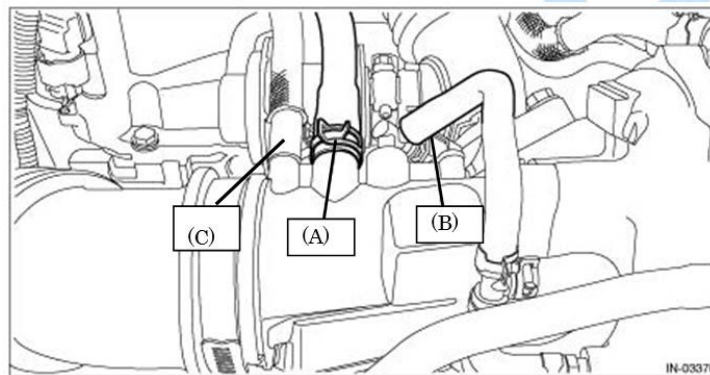

- Reconnect the wiring harness connector to the waste gate control solenoid valve.

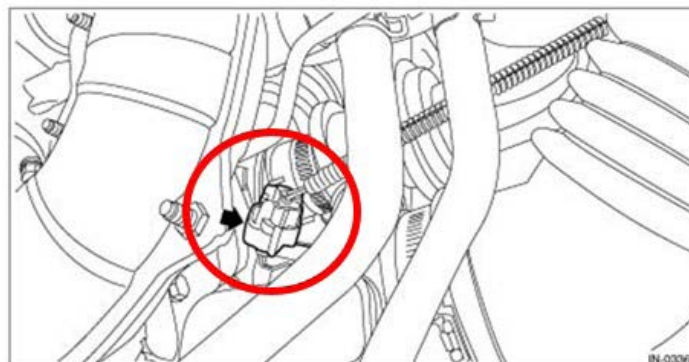

Continued...

- Reinstall the undercover following the procedure in the applicable Service Manual.

CAUTION: Make sure the front edge of the under cover (b) fits inside the the bumper cover (a) as shown in the illustrations below.

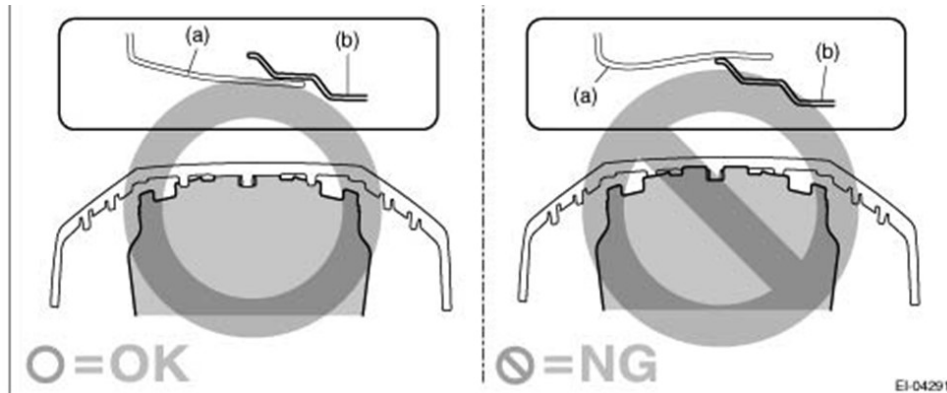

- Clean the battery cable terminals and apply grease to prevent corrosion.
- Reconnect the battery, positive (+) terminal first.
- Reconnect the negative (-) cable while holding the battery sensor to prevent it from rotating on the battery post. Torque the 12mm nut to 7.35 Nm (5.5 ft. lbs.).
- **IMPORTANT:** Wait at least 10 seconds after reconnecting the battery ground terminal before switching the ignition on to allow initial diagnosis of the electric throttle control. This will prevent setting DTCs. After switching the ignition on, **wait another 10 seconds** before starting the engine.

RECALL CAMPAIGN IDENTIFICATION LABEL

Type or print the necessary information on a Campaign Identification Label. The completed label should be attached to the vehicle's upper radiator support.

Additional labels are available through normal parts ordering channels. The part number is MSA6P1302, which comes as one sheet of 20 labels.

| Part Number | Applicability | Description | Order Quantity |
|-------------|---------------|-----------------------------------------------------------------|----------------|
| MSA6P1302 | All models | Campaign Completion Labels (contains one sheet of 20 labels) | 1 |

| |
|----------------------|
| SUBARU |
| Campaign Code |
| WTA-62 |
| COMPLETED |
| DIST./DEALER NO. |
| SERIAL NO. |
| DO NOT REMOVE |

Continued...

CALIFORNIA “VEHICLE EMISSION RECALL - PROOF OF CORRECTION” CERTIFICATE

The California Air Resources Board and the Department of Motor Vehicles Registration/Recall Program requires that all emission related Recall/Campaign or Service Program repairs be completed before a vehicle registration is renewed. Please provide owners of vehicles registered in the state of California a completed “Vehicle Emission Recall - Proof of Correction” certificate. Vehicle owners should be advised to retain this certificate because the California Department of Motor Vehicles may require they provide proof this service program repair has been completed.

Additional certificates are available through normal parts ordering channels using part number MSA6P1301. Quantity 1 = 1 booklet of 50 certificates.

CLAIM REIMBURSEMENT AND ENTRY PROCEDURES

Credit to perform this service campaign will be based on the submission of properly completed repair order information. Retailers may submit claims through Vehicle Claim Entry on subarunet.com.

| Labor Description | Labor Operation # | Labor Time | Failure Code | Claim Type |
|------------------------------------------------|-------------------|------------|--------------|------------|
| Turbocharger Air Intake Duct Inspection Only | A145-138 | 0.2 | WTA-62 | RC |
| Turbocharger Air Intake Duct Inspect & Replace | A145-131 | 0.5 | | |

IMPORTANT REMINDERS:

- SOA strongly discourages the printing and/or local storage of service information as previously released information and electronic publications may be updated at any time.
- Always check for any open recalls or campaigns anytime a vehicle is in for servicing.
- Always refer to STIS for the latest service information before performing any repairs

Continued...

OWNER NOTIFICATION LETTER

IMPORTANT SAFETY RECALL

This notice applies to the VIN identified in the address section printed below.



SUBARU

Subaru of America, Inc
Subaru Plaza
PO Box 6000
Cherry Hill, NJ 08034-6000
800-782-2783
www.subaru.com

**Subaru Recall Campaign WTA-62
NHTSA Recall No. 16V-162
April 2016**

Dear Subaru Owner:

This notice is sent to you in accordance with the National Traffic and Motor Vehicle Safety Act.

Subaru of America, Inc. has decided that a defect which relates to motor vehicle safety exists in certain 2015-2016 model year Subaru Forester 2.0XT and WRX vehicles.

You received this notice because our records indicate that you currently own one of these vehicles.

DESCRIPTION OF THE SAFETY DEFECT & SAFETY HAZARD

The engine turbocharger air intake duct may have been produced with an incorrect material that is susceptible to cracking. Should the engine turbocharger air intake duct crack, the engine may develop an abnormally rough idle, reduced power and possibly stall. Should the engine suddenly lose power or stall while driving, there is an increased risk of a crash.

In addition, this condition may cause the "Check Engine" light located on the instrument panel to illuminate, indicating a malfunction has occurred. It could also have an adverse effect on vehicle exhaust emissions.

DESCRIPTION OF THE REMEDY

Subaru will inspect the lot number molded on the engine turbocharger air intake duct to determine if it was produced with incorrect material. If a specific lot number is found, the duct will be replaced. If a different lot number is found, the duct was produced using the correct material and replacement is not necessary. The inspection and, if necessary, the repair will be performed at no cost to you.

WHAT YOU SHOULD DO

You should immediately contact your Subaru retailer (dealer) for an appointment to have your vehicle inspected and repaired, if necessary.

There are several important precautions you should take until this recall has been performed:

- If you notice an abnormally rough engine idle or the "Check Engine" light located on the instrument panel illuminates while the engine is running, do not drive the vehicle. Contact your Subaru retailer for assistance.
- If there is a loss of power or the engine stalls while driving, carefully steer the vehicle to a safe place on the side of the road. Do not continue to operate the vehicle. Immediately contact your Subaru retailer for assistance.

HOW LONG WILL THE REPAIR TAKE?

The time to perform the actual inspection is approximately 10 minutes. If replacement of the engine air duct is required, the repair will take an additional 20 minutes. However, it may be necessary to leave your vehicle for a longer period of time on the day of your scheduled appointment to allow your Subaru retailer flexibility in scheduling.

Continued...

CHANGED YOUR ADDRESS OR SOLD YOUR SUBARU?

If you have moved or sold your vehicle, please complete the enclosed prepaid postcard and mail it to us. Or if you prefer to update this information online, please go to www.subaru.com, select 'Customer Support,' then select 'Address Update' or 'Ownership Update' from the drop down menu.

IF YOU NEED FURTHER ASSISTANCE:

To locate the nearest Subaru retailer you can access our website at www.subaru.com and select 'Find a Retailer.'

For additional information, please go to:

- <http://www.wta62.service-campaign.com>.

If you need additional assistance, please contact us directly:

- By e-mail: Go to www.subaru.com, Customer Support and select "Contact Us"
- By telephone: 1-800-SUBARU3 (1-800-782-2783)
Monday through Thursday between 7:30 a.m. and 8:00 p.m. ET
Friday between 10:30 a.m. and 5:00 p.m. ET
Saturday between 9:00 a.m. and 3:30 p.m. ET
- By U.S. Postal mail: Write us at Subaru of America, Inc., Attn: Customer-Retailer Services Department, P.O. Box 6000, Cherry Hill, NJ 08034-6000

Please contact us immediately if the Subaru retailer fails or is unable to make the necessary repairs free of charge.

You may also contact the Administrator, National Highway Traffic Safety Administration, 1200 New Jersey Ave. SE, West Building, Washington, DC 20590 or call the toll free Auto Safety Hotline at 1-888-327-4236 (TTY: 1-800-424-9153) or go to <http://www.safercar.gov> if you believe the Subaru retailer has failed or is unable to remedy your vehicle without charge within a reasonable amount of time.

CALIFORNIA REGISTERED OWNERS

The California Air Resources Board requires that emission related campaigns be completed prior to California's vehicle registration renewal process; without this repair, you will not be able to register your vehicle during your next annual registration. Upon completion of this campaign, your California dealer will complete and provide you a "Proof of Correction Certificate." If required, present the certificate to the California Department of Motor Vehicles (the "DMV") when renewing your California registration as proof of campaign completion. If the DMV does not request the certificate, we recommend that you keep it for your records.

In addition, the State of California requires that every vehicle must pass an emission test (SMOG Check) every two years and before it is sold. Without the service we are providing at no charge, your vehicle may not pass this test.

Your continued satisfaction with your Subaru is important to us. Please understand that we have taken this action in the interest of your safety and your vehicle's proper operation. We sincerely apologize for any inconvenience this matter may cause and urge you to schedule an appointment as soon as possible to have this repair performed.

Sincerely,

Subaru of America, Inc.

Notice to Lessors: Under Federal law the lessor of a vehicle who receives this letter must provide a copy of it to the vehicle lessee(s) within 10 business days from receipt. The lessor must also keep a record of the lessee(s) to whom this letter is sent, the date sent, and the applicable vehicle identification number (VIN). (For the purposes of this section, a lessor means a person or entity that in the last twelve months prior to the date of this notification has been the owner, as referenced on the vehicle's title, of any five or more leased vehicles. A leased vehicle is a vehicle leased to another person for a term of at least four months.)

A subsidiary of Fuji Heavy Industries Ltd.