

REFERENCE:	Nova Bus Manuals
SECTION:	03 : Wipers/washers, windshield
RS N°:	MQR 7621-1027
EFFECTIVE IN PROD.:	L944 (2016FE)
TC RECALL N°:	2016-104
NHTSA RECALL N°:	16v-135

APPLICATION DEADLINE: N/A  
CLAIM REFERENCE NUMBER: SR-3642

SUBJECT:	Windshield wiper system
JUSTIFICATION:	Windshield wiper idler arm pin might strip.

LEVEL	DESCRIPTION	DIRECT CHARGES		TIME
		LABOUR	MATERIAL	
1	Replace the linkage assembly.	Nova Bus	Nova Bus	3h
2	-	-	-	-

**MATERIAL**

QTY	PART N°	REV.	DESCRIPTION	REPLACES PART N°
<b>LEVEL 1</b>				
1	N8904046	NR	Welded wiper linkage kit	-
<b>LEVEL 2</b>				
-	-	-	-	-

Materials will be available within 112 days. To order, please contact Prevost Parts by phone at 1-800-771-6682, by fax at 1-888-668-2555 or by email at prevostparts.commandes@volvo.com. Specify document number, quantity of parts required and shipping address.

**DISPOSAL OF PARTS**

REMOVED PARTS ARE:	DISCARDED	RETAINED *	* To be reimbursed, the parts must be retained and returned in accordance with the usual warranty procedure.
	-	Yes	

**REVISION HISTORY**

REV.	DATE	CHANGE DESCRIPTION	WRITTEN BY
NR	2016AV18	Initial release	André Pelletier
R1	2016AV22	Page 1: Removed parts must be " <b>RETAINED</b> ". Part under "Replaces part N°" removed. Page 2-3-4 : client list modified. Pages 8-9-12 added conversion for N·m to lb-ft. Shifted texts repositionned.	André Pelletier

APPROVED BY:

Symbol	Meaning
Empty Field	No changes, the procedure applies
+	Contract added, the procedure applies
-	Contract removed, remedy applied before delivery

	CLIENT	ORDER	ROAD NUMBER		VIN (2NVY/4RKY...)		QTY
			FROM	TO	FROM	TO	
	Barrie - Ontario	L878	1501	1504	L82JXF3001691	L82J6F3001719	4
	BC Transit - BCT - British Columbia	L858	9447	9481	L82JXE3001401	L82J5F3001436	35
	BC Transit - BCT - British Columbia	L891	9482	9486	L82J5F3001565	L82J2F3001569	5
	Belleville Ontario (ref. L962)	L840	—	—	L82J9E4500715	L82J9E4500715	1
	Brampton - Ontario	L864	1501	1510	L82JXF3001500	L82J6F3001509	10
	Brampton - Ontario	L865	1511	1519	L82JXF3001514	L82J9F3001522	9
-	Brampton - Ontario	L942	1602	1610	L82J8G3750071	L82J9G3750080	8
	Brantford - Ontario	L928	10151	10153	L82J7F3001793	L82J0F3001795	3
	Burlington - Ontario	L887	7017-15	7025-15	L82J7F3001681	L82J8F3001723	9
	Chicago Transit Authority - CTA - Illinois	L847	8000	8049	L82J1E4500773	L82JXE4500822	50
	Chicago Transit Authority - CTA - Illinois	L848	8050	8099	L82JXF4500823	L82J1F4500872	50
	Chicago Transit Authority - CTA - Illinois	L849	8100	8149	L82J5F4500874	L82J3F4500923	50
	Chicago Transit Authority - CTA - Illinois	L850	8150	8186	L82J5F4500924	L82J8F4501274	37
	CNG Demo (ref. L957)	L840	—	—	L82J0E4500716	L82J0E4500716	1
	Cornwall Ontario	L935	—	—	L82J3F3001838	L82J5F3001839	2
	Durham Region Transit - Ontario	L872	8551	8553	L82J0F3001523	L82J4F3001525	3
	Durham Region Transit - Ontario	L888	8554	8559	L82J2F3001703	L82J1F3001708	6
	Fredericton - New Brunswick	L836	8143	8143	L82J9E3001390	L82J9E3001390	1
	Fredericton - New Brunswick	L901	8151	8151	L82J7F3001602	L82J7F3001602	1
	Grande Prairie Alberta	L834	—	—	L82J7E3001386	L82J2E3001389	4
	Guelph - Ontario	L835	240	243	L82J0E3001391	L82J6E3001394	4
	Guelph - Ontario	L927	244	247	L82J1F3001756	L82J9F3001763	4
	Hamilton - Ontario	L885	1501	1524	L82K3F4501093	L82K0F4501214	24
	Kingston Ontario	L880	1502	1502	L82JXF3001786	L82JXF3001786	1
	Kingston Ontario	L925	1504	1510	L82J5F3001808	L82J5F3001811	4
	Lethbridge - Alberta	L868	180	180	L82J2F3001510	L82J2F3001510	1
	New York City Transit - New York	L841	8094	8175	L82J2F4500959	L82J2F4501075	82
	New York City Transit - New York	L842	8090	8213	L82J4F4501076	L82J7F4501170	86
	New York City Transit - New York	L843	8215	8338	L82J2F4501173	L82JXF4501260	65
	New York City Transit - New York	L843	8340	8380	L82J8G9775000	L82J9G9775023	15
	New York City Transit - New York	L844	8381	8388	L82J0G9775024	L82J8G9775031	8
	New York City Transit - New York	L844	8433	8456	L82JXG9775032	L82J0G9775055	24
	New York City Transit - New York	L844	8231	8251	L82J2G9775056	L82J8G9775076	21
	New York City Transit - New York	L844	8492	8495	L82JXG9775077	L82JXG9775080	4
	New York City Transit - New York	L844	8497	8497	L82J3G9775082	L82J3G9775082	1
	New York City Transit - New York	L845	8308	8308	L82J5G9775133	L82J5G9775133	1
	New York Demo	L940	—	—	S92J7F4501257	S92J7F4501257	1

	CLIENT	ORDER	ROAD NUMBER		VIN (2NVY/4RKY...)		QTY
			FROM	TO	FROM	TO	
	New York Demo	L840	8090	8091	L82J5E4500713	L82J7E4500714	2
	NFTA - Buffalo, New York	L877	1501	1501	L82K0F4500984	L82K0F4500984	1
	NFTA - Buffalo, New York	L897	1502	1505	L82K1F4501223	L82K9F4501244	4
	NFTA - Buffalo, New York	L897	1515	1515	L82K0F4501279	L82K0F4501279	1
	North Bay - Ontario	L895	784	785	L82J7F3001678	L82J9F3001679	2
	Oakville - Ontario	L874	—	—	L82J6F3001526	L82JXF3001531	6
	Oakville - Ontario	L881	—	—	L82J2F3001717	L82J8F3001740	5
	Peterborough - Ontario	L870	61	63	L82JXF3001612	L82J3F3001614	3
	Peterborough - Ontario	L919	64	66	L82J6F3001767	L82JXF3001769	3
	Red Deer - Alberta	L813	10008	10009	L82J2E3001361	L82J4E3001362	2
	Red Deer - Alberta	L869	10006	10007	L82J9F3001570	L82J0F3001571	2
	Red Deer - Alberta	L926			L82J2F3001796	L82J4F3001797	2
	Regina - Saskatchewan	L892	686	691	L82J5F3001484	L82J4F3001489	6
	Sarnia Ontario	L873	151	152	L82J0F3001599	L82J0F3001600	2
—	Sarnia Ontario	L883	153	153	L82J4G3750021	L82J4G3750021	1
	Saskatoon - Saskatchewan	L894	1501	1510	L82J0F3001490	L82J7F3001499	10
	Sault Ste. Marie Ontario	L934	—	—	L82JXG3750038	L82JXG3750038	1
	SEPTA - Pennsylvania	L742	7371	7414	S92L6E4500729	S92L7E4500772	44
	SEPTA - Pennsylvania	L745	7415	7415	S92L0F4500873	S92L0F4500873	1
	SEPTA - Pennsylvania	L746	7416	7454	S92L7F4500952	S92L8F4501012	39
	St. Catharines Ontario	L879	1501	1504	L82J4F3001587	L82J4F3001590	4
	St. Catharines Ontario	L898	1560	1560	S92J4F3001663	S92J4F3001663	1
	St. John - New Brunswick	L871	40585	40586	L82J8F3001592	L82JXF3001593	2
—	St. John - New Brunswick	L939	40687	40687	L82J0G3750078	L82J0G3750078	1
	St. John's - Newfoundland	L875	1520	1525	L82JXF3001478	L82J3F3001483	6
	St. John's - Newfoundland	L930	1626	1630	L82J7F3001826	L82J9F3001830	5
	Stratford - Ontario	L893	—	—	L82J9F3001584	L82J0F3001585	2
	Sudbury - Ontario	L890	851	855	L82JXF3001609	L82J6F3001641	5
	Thunder Bay - Ontario	L863	—	—	L82J8F3001558	L82J6F3001560	3
	Timmins - Ontario	L839	—	—	L82J8E3001395	L82J8E3001395	1
	Toronto Transit Commission - TTC - Ontario	L859	8400	8400	L82J5F3001405	L82J5F3001405	1
	Toronto Transit Commission - TTC - Ontario	L860	8401	8504	L82J0F3001554	L82JXF3001805	104
	Toronto Transit Commission - TTC - Ontario	L937	8510	8514	L82J9G3750001	L82J6G3750005	5
	Toronto Transit Commission - TTC - Ontario	L937	8519	8525	L82JXG3750010	L82J4G3750018	7
	Toronto Transit Commission - TTC - Ontario	L937	8527	8539	L82J2G3750020	L82J1G3750042	13
	University of Alabama - Alabama	L902	7030	7030	L82J2F4500993	L82J4F4500994	2
	Vancouver Airport Authority - YVR British Columbia	L912	173	178	L82L5F3001812	L82L4F3001817	6
	Welland Ontario	L866			L82J9F3001648	L82J9F3001648	1
	Welland Ontario	L933	—	—	L82J1G3750011	L82J1G3750011	1
	Windsor - Ontario	L886	570	572	L82J8F3001818	L82J6F3001820	3
	Windsor - Ontario	L886	574	575	L82JXF3001822	L82J1F3001823	2
	Windsor - Ontario	L886	577	577	L82J5F3001825	L82J5F3001825	1

	CLIENT	ORDER	ROAD NUMBER		VIN (2NVY/4RKY...)		QTY
			FROM	TO	FROM	TO	
	Woodstock - Ontario	L832	—	—	L82J9E3001342	L82J9E3001342	1
	Woodstock - Ontario	L923	15-16	15-16	L82J9F3001746	L82J9F3001746	1
	York Regional Transit - Ontario	L896	1501	1517	L82J2F3001619	L82JXF3001741	17
	York Regional Transit - Ontario	L936	1518	1518	L82J3G3750012	L82J3G3750012	1



**WARNING**

Follow your internal safety procedures. Before starting any work on the vehicle, make sure the vehicle is completely and securely stationary.

**PROCEDURE FOR LINKAGE REPLACEMENT**

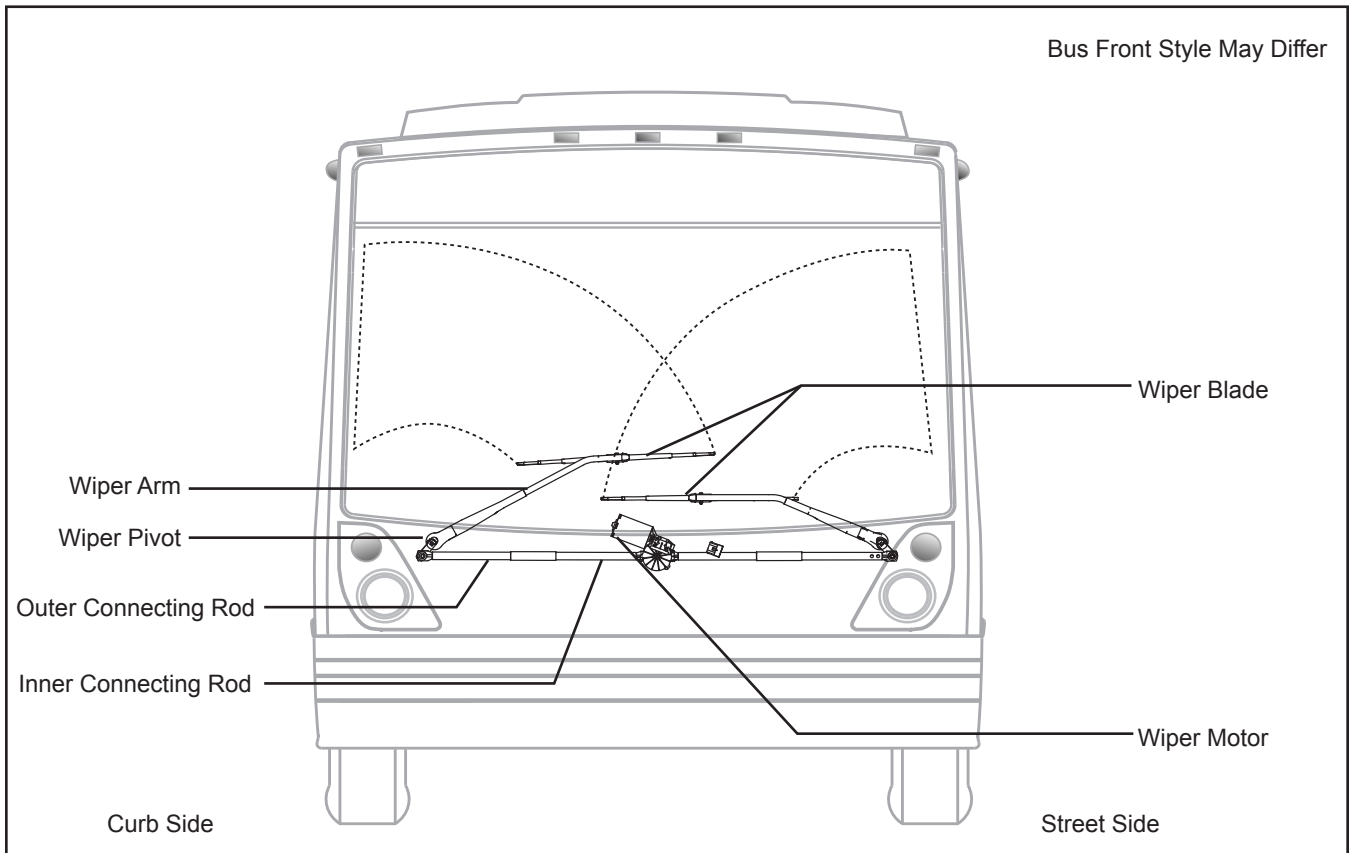

*Figure 1 - Windshield Wiper System*

- 1.1. Ensure the replacement linkage has a green dot. See Figure 2. This is to identify that the linkage is welded on the back side, which is difficult to see after installation.

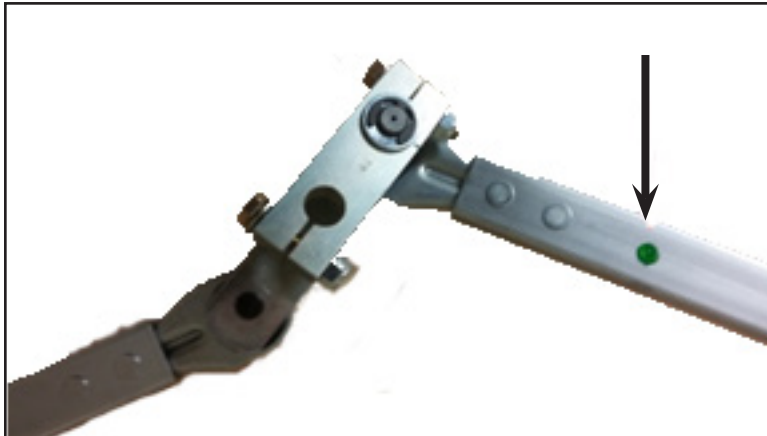

Figure 2 - Confirm Linkage Has a Green Dot

- 1.2. To make sure the wiper system is parked correctly, activate the wipers at low speed and, as soon as they reach maximum position, turn the switch OFF to deactivate the wipers. The system will return the wipers to park position.



#### CAUTION

Place the battery disconnect switch in the OFF position and lock it out. There is a risk of serious injury if the motor is powered and it detects that the system is not in the park position: it can activate automatically to complete a full cycle, even if there no demand.



#### NOTE

Retain hardware removed during the procedure for later reinstallation.

- 1.3. Remove driver handrail.
- 1.4. To acces the wiper system on the street side, remove driver foot shields and the farebox (if necessary). For the curb side, remove the acces panel under the dash.

1.5. Install tape on the inside face of the windshield to mark the wiper blade positions. See Figure 3.

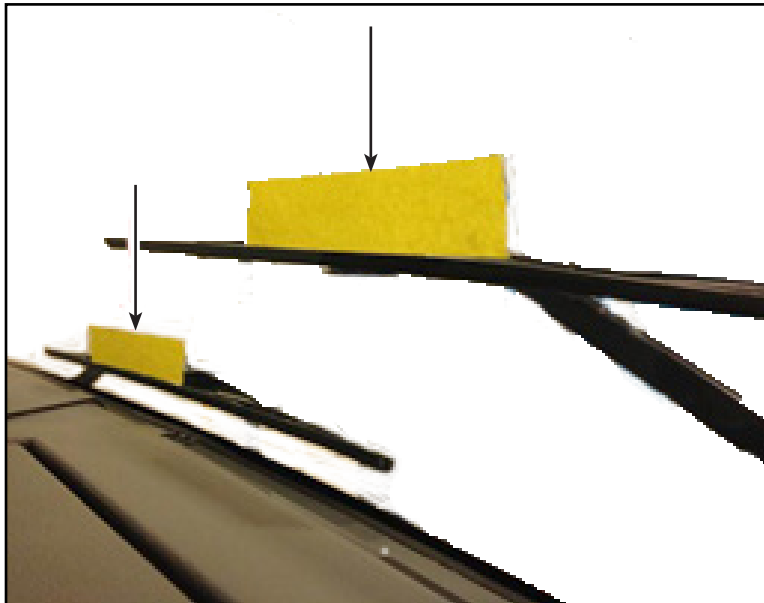

*Figure 3 - Put Two Pieces of Tape Inside the Vehicle*

1.6. Tape the wiper blades on the windshield to maintain their position. See Figure 4.

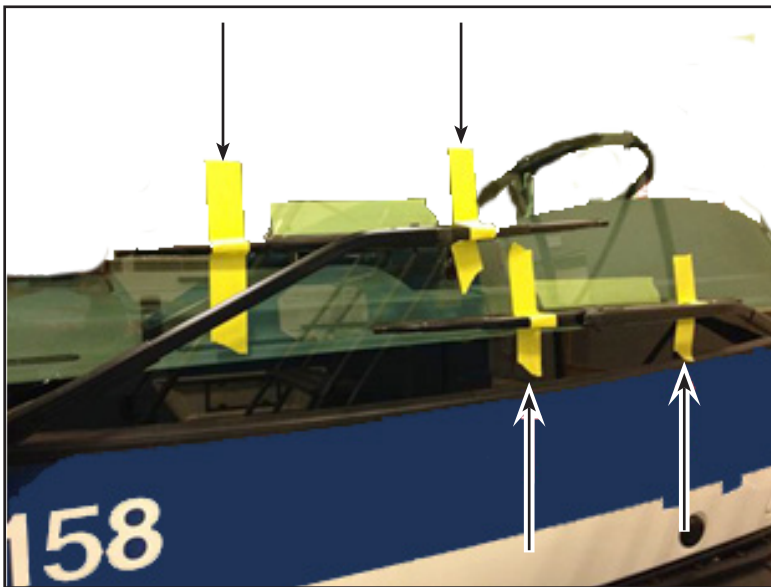

*Figure 4 - Tape the Wiper Blades*

- 1.7. Before removing the original linkage assembly, make a mark at the joint on each side of the 4 bolts. In order to facilitate the repositioning of the new linkage assembly. See Figure 5. Typical for curb and street sides.

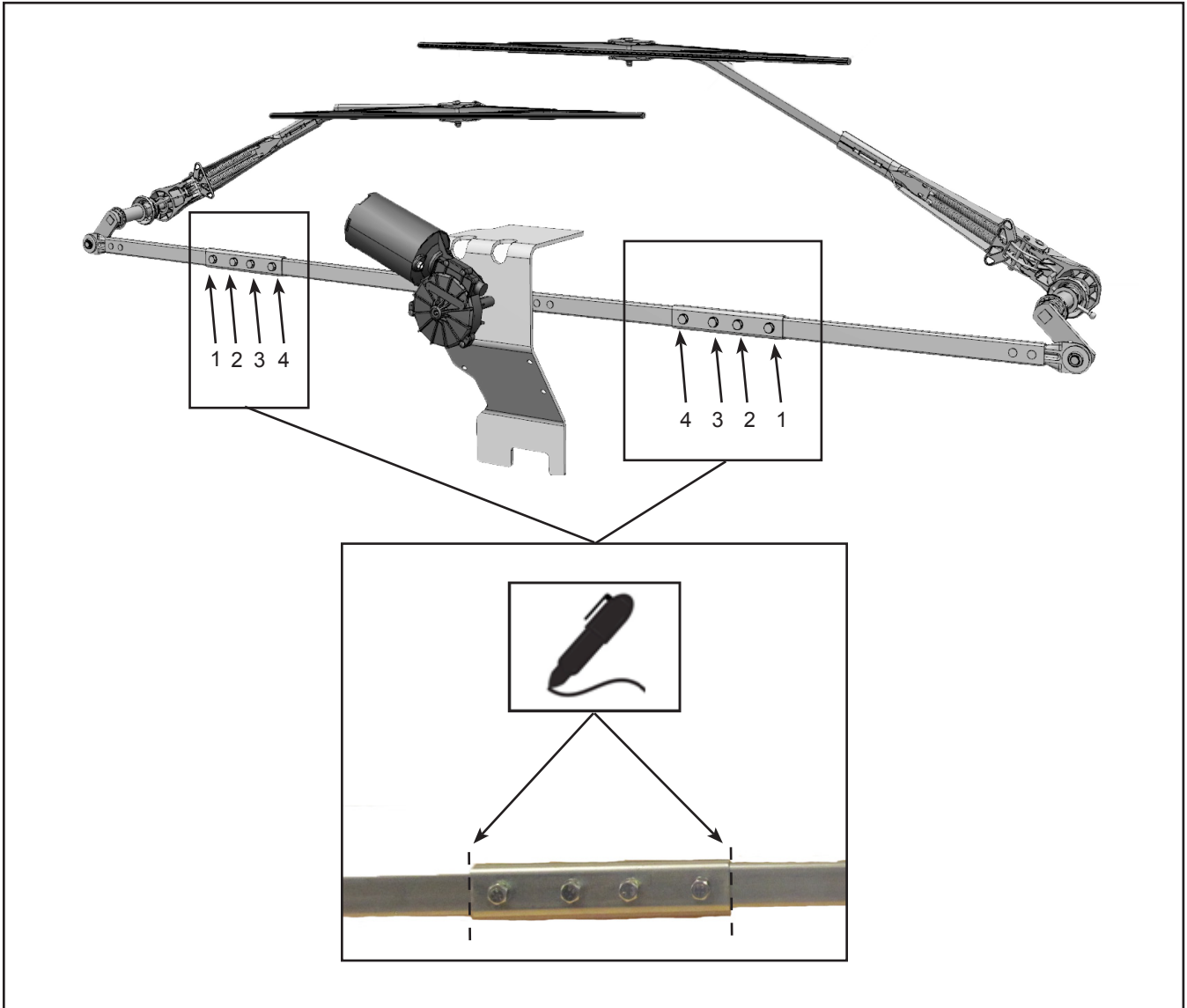

Figure 5 - Make Marks on the Linkage  
(Typical for Curb and Street Sides)

- 1.8. Remove bolts #3 and #4, then loosen bolts #2. Leave bolts #1 tight on both sides. See Figure 5 for the bolt positions.

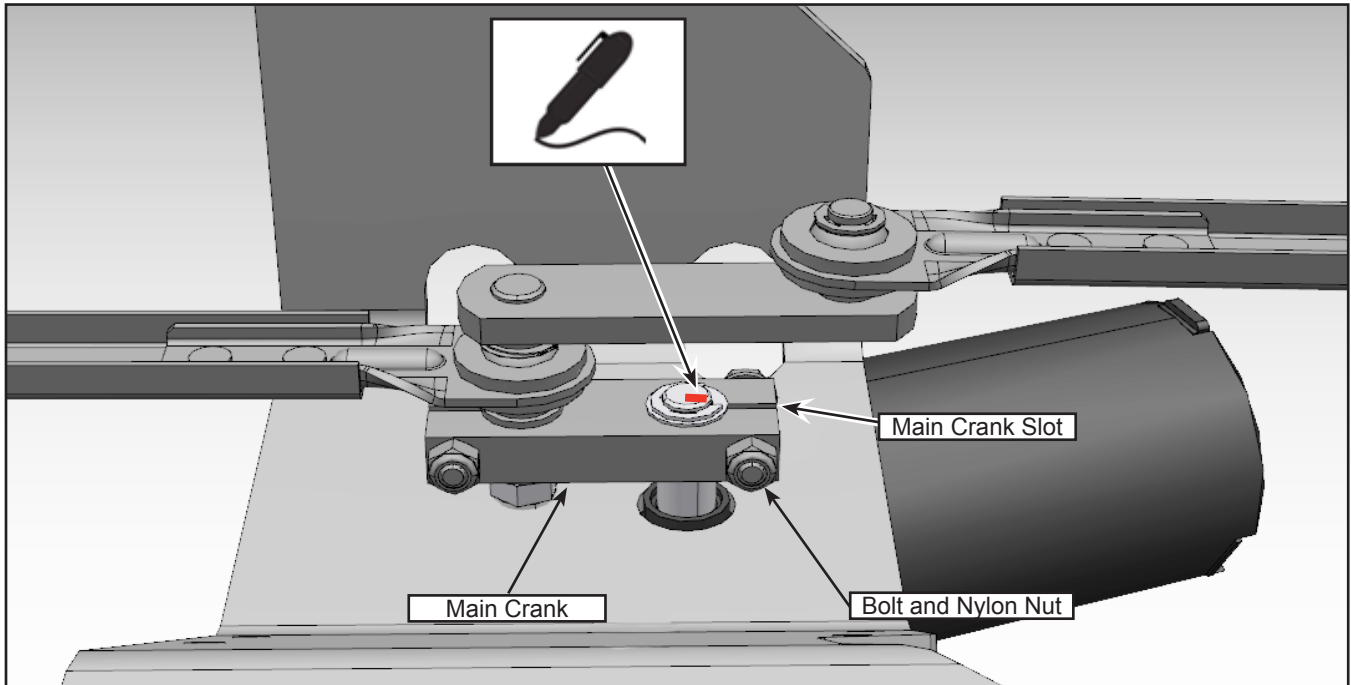

Figure 6 - Mark the Position on the Shaft and Remove the Main Crank

- 1.9. Remove the C-clip on the motor shaft. Make a mark on the motor shaft to identify the position of the slot of the main crank. See Figure 6.
- 1.10. Remove the bolt and nylon nut from the main crank. See Figure 6.
- 1.11. Slide the main crank off the motor shaft and remove the linkage assembly.



**NOTE**

If necessary, insert a flat screwdriver in the main crank slot to open it slightly. Be careful not to rotate the motor shaft.

- 1.12. Measure and record the dimensions according to the marks made at step 1.7: dimension "A" for street side and "B" for curb side. Transfer these dimensions to the new linkage. See Figure 7.

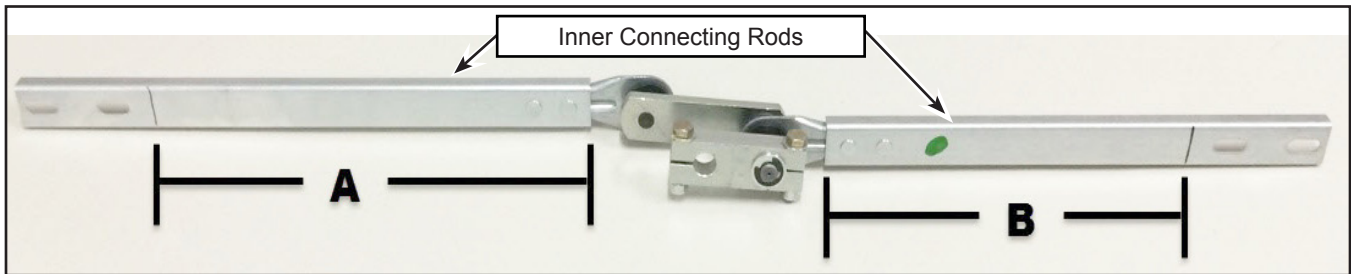

Figure 7 - Transfer Dimensions A and B to the New Linkage Assembly

- 1.13. Install the new linkage by inserting the new inner rods to both sides of the original outer connecting rods.
- 1.14. Place bolts #3 and #4 on both sides with the serrated washers, but leave them loose for now.
- 1.15. Slide the main crank onto the motor shaft splines. The main crank must be horizontal  $\pm 3^\circ$ . Make sure to align the mark made at step 1.9 with the slot on the main crank. See Figure 8. Put the C-clip.

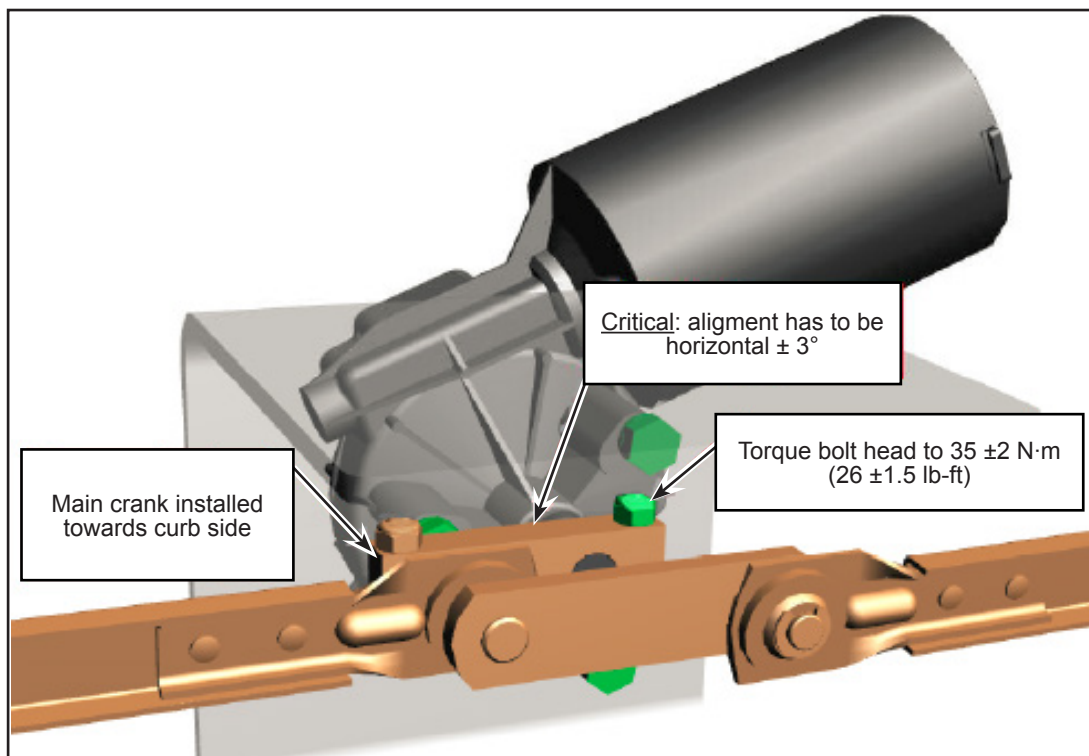

Figure 8 - Install the Main Crank

- 1.16. Reposition as needed to obtain the correct spline fit.
- 1.17. Set the connecting rods on both sides according to the previously made marks and tighten the eight bolts to  $24.5 \pm 2.5$  N·m ( $18 \pm 2$  lb-ft).

**NOTE**

---

The rods on both sides should be the same length as the originals. Performing that step before torquing the main crank bolt will prevent the motor from rotating.

- 1.18. Torque the main crank bolt head on the motor shaft to  $35 \pm 2$  N·m ( $26 \pm 1.5$  lb-ft). Apply anti-tamper seal. See Figure 8.

**WIPER POSITION VALIDATION**

- 1.19. Remove tape on the wiper blades. Refer to Figure 4.
- 1.20. Unlock the battery switch and turn it to the ON position.
- 1.21. Confirm that the entire mechanism is secure and free from any possible interference during movement.
- 1.22. Validate there is no free rotation at the wiper pivots.
- 1.23. Activate the wiper system and let it park as described in step 1.2.
- 1.24. Validate that the wiper blades lines up with the tape put inside the windshield, as seen in Figure 3, step 1.5. The blades should not have a negative angle.
- 1.25. If validation conditions are met, remove tape on the inside of the windshield and reinstall all the parts removed.
- 1.26. If validation conditions are not met, proceed to the **WIPER ADJUSTMENT PROCEDURE**.

**WIPER ADJUSTMENT PROCEDURE**

1.27. Lift the curb side wiper arm and install the Doga tool (yellow) to keep the arm straight. See Figure 9.

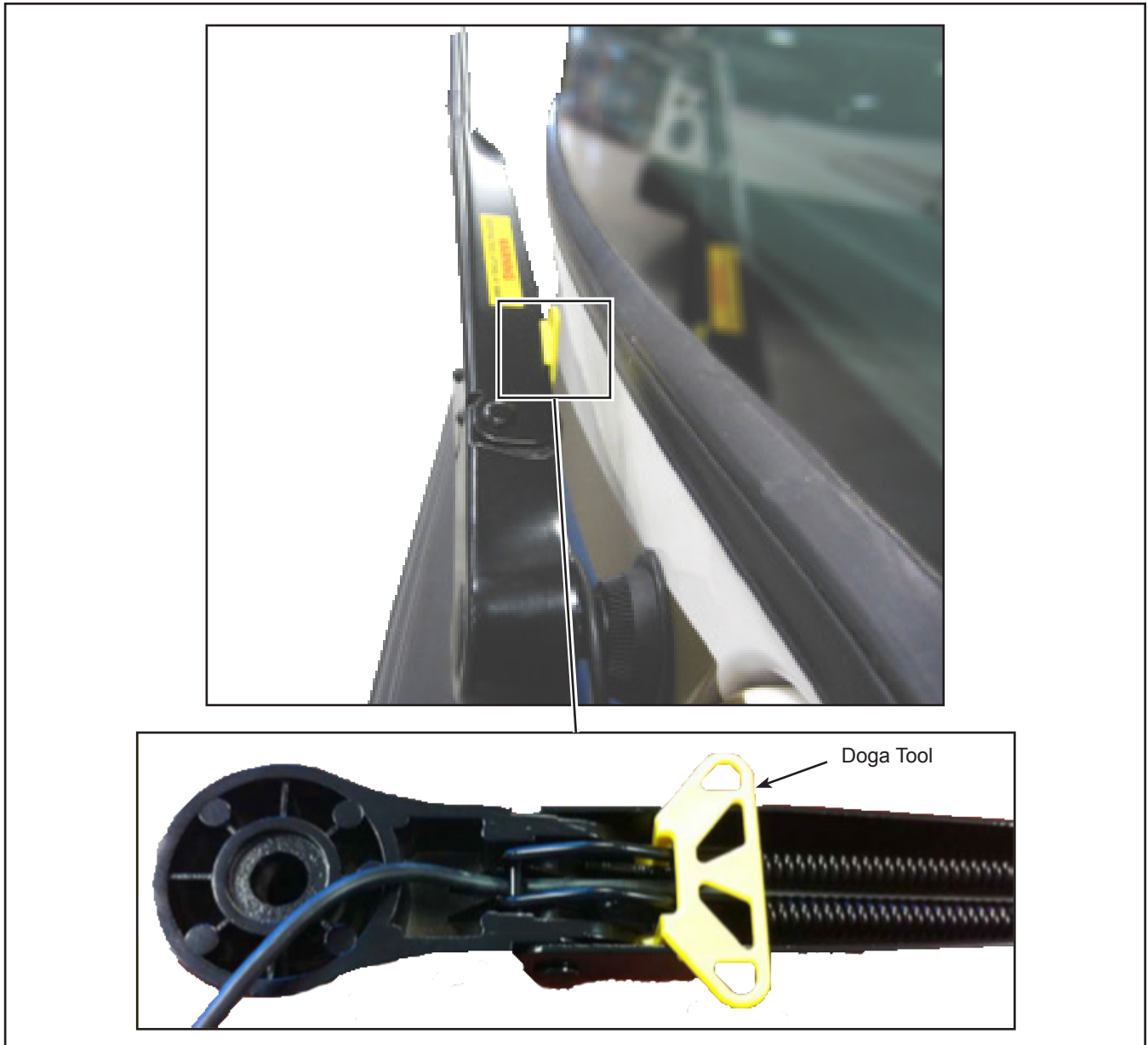

*Figure 9 - Install the Doga Tool*

1.28. Loosen the pivot nut by a few threads. See Figure 10.

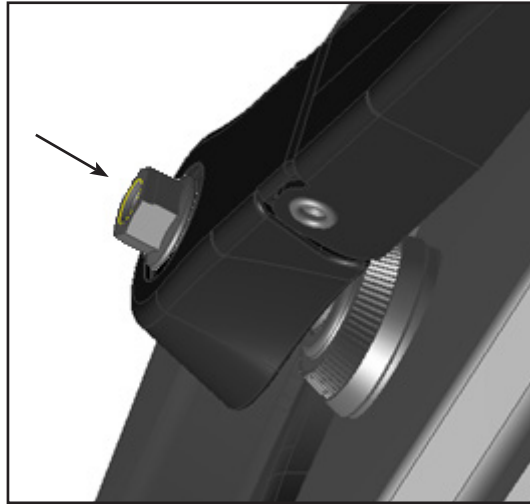

*Figure 10 - Loosen the Pivot Nut*

1.29. Use an extractor tool to pull the wiper arm away. See Figure 11.



*Figure 11 - Pull the Wiper Away*

- 1.30. Adjust the curb side wiper arm up or down as required. At installation, the angle should be  $1^\circ$  for the wiper blade on the curb side, see Figure 12, and  $2^\circ$  on the street side.

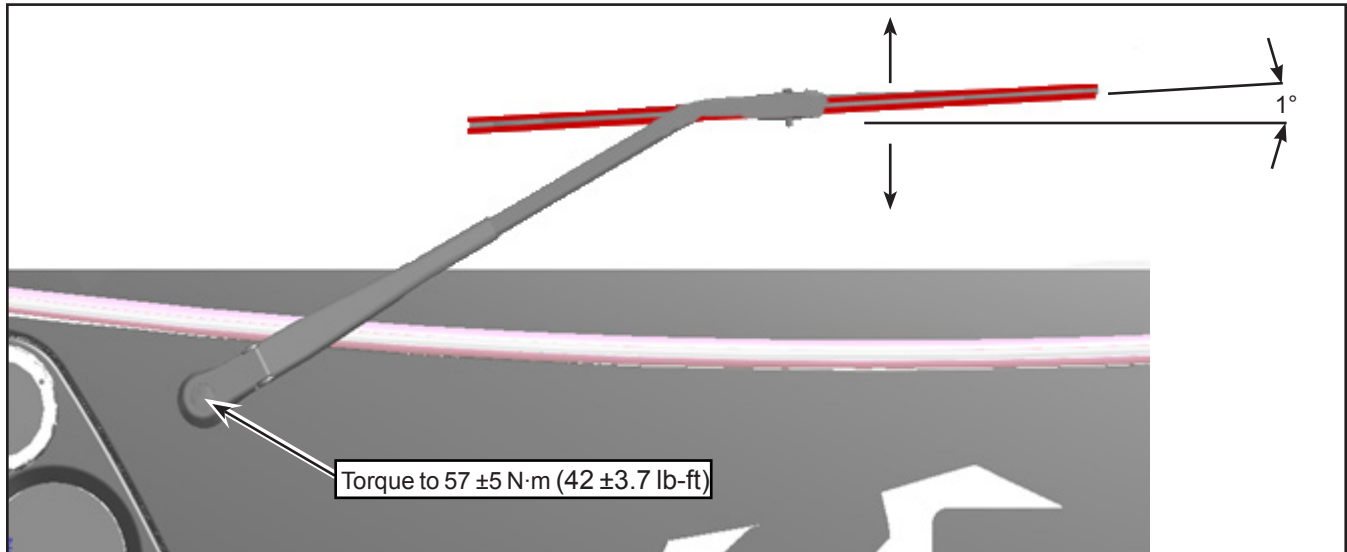

Figure 12 - Adjust the Wiper Arm

- 1.31. Remove the Doga tool.
- 1.32. Maintain the wiper arm in place while torquing at  $57 \pm 5$  N·m ( $42 \pm 3.7$  lb-ft). See Figure 13.
- 1.33. Activate the wiper system and let it park as described in step 1.2.
- 1.34. Validate that the wiper blades lines up with the tape put inside the windshield, as seen in Figure 3, step 1.5.
- 1.35. The wiper on the street side should go back to horizontal,  $0^\circ$ , and the wiper on the curb side should be at  $1^\circ$ . They should not have a negative angle.
- 1.36. Repeat **WIPER ADJUSTMENT PROCEDURE** if necessary.
- 1.37. If validation conditions are met, remove tape on the inside of the windshield and reinstall all the parts removed for access. ❖