

MODEL: 2016 Ninja® ZX™-10R/10R ABS**TITLE:** STEERING DAMPER BRACKET MOUNTING BOLTS

RECALL

THIS BULLETIN IS OF THE HIGHEST PRIORITY AND MUST BE ACTED UPON IMMEDIATELY TO ENSURE CUSTOMER SAFETY.

Eligibility

Eligible Units		
Year	Model	Vehicle Identification Number Eligibility
2016	ZX1000RGFL/AL ZX1000SGFL/AL	Check VIP in K-Dealer

Verify eligibility using VIP in K-Dealer before starting the repair.

Please check VIP (Vehicle Information Portal) in K-Dealer for other possible repair campaigns for eligible units.

Subject

On eligible units, the steering damper bracket mounting bolts could break due to over tightening during assembly causing the steering damper bracket to detach from the frame. The unfastened steering damper bracket could result in steering interference creating the potential for a crash resulting injury or death.

Kawasaki Action

Initiate Campaign

Kawasaki has initiated a Recall campaign to repair all eligible units. The repair consists of replacing the steering damper bracket mounting bolts.

Notify Registered Owners:

Kawasaki is sending a Recall letter to all registered owners of eligible units. A copy of the letter is printed on page 4 of this bulletin.

Dealer Action

Repair Eligible Units:

Repair all eligible units including sold units in the field and unsold units in your dealership inventory prior to delivery to the retail purchaser. It is the obligation of authorized Kawasaki retail Dealers to repair eligible units in Dealer's possession prior to retail sale. Failure to comply with this obligation to repair all units eligible for Recall or FDM campaigns by the Dealer constitutes a breach of the Dealer Sales and Service Agreement. Refer to Service Policies bulletin SP 08-01. Refer to the Repair Procedure section of this bulletin for details.

IMPORTANT NOTE:

- o *It's the law! Under the U.S. National Highway Traffic Safety Administration (NHTSA), Federal Law 49 U.S.C. Section 30120(i) requires dealers to perform Recall repairs before delivering any vehicle affected by the Recall to a purchaser.*

Document Completed Repairs:

Federal law requires manufacturers to maintain accurate follow-up records on repairs performed on eligible units. Dealers MUST submit a Warranty Claim for each repair. Refer to the Warranty Information section of this bulletin for details.

NOTE:

- o *If you fail to submit a Warranty Claim for a new unit that is subsequently sold and registered, the new owner will receive the Recall letter requesting the return of the vehicle to you for repair.*

Submit Product Registration:

Submit the product registration to Kawasaki via K-Dealer immediately after retail sale of any eligible unit. Be sure to supply the correct customer name and mailing address. Kawasaki uses the product registration information for customer notification. Also, if you know that the customer has moved, please submit a Customer Update via K-Dealer.

Repair Procedure

- Remove the fuel tank covers (three pieces) as outlined on pages 15-16 & 15-17 of service manual 99924-1509-01.
- Remove and discard the left steering damper bracket mounting bolt.
- Install the new left bolt finger tight only.
- Remove and discard the right steering damper bracket mounting bolt.
- Install the new right bolt finger tight only.

IMPORTANT NOTE:

- o *Insure that all wires and tubing running under the steering damper bracket remain in their proper positions.*

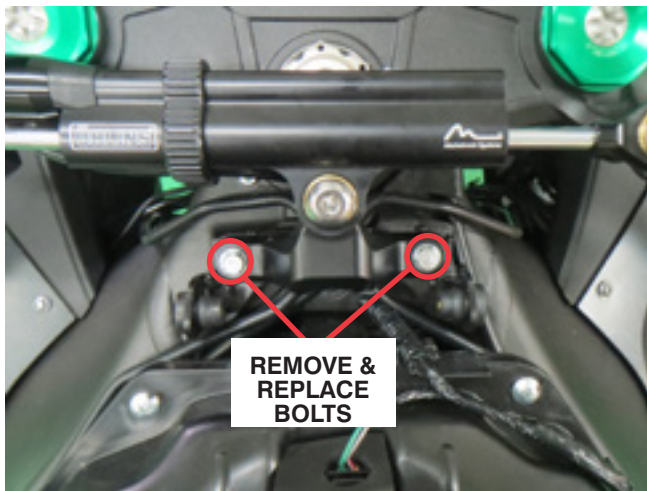

IMPORTANT NOTE:

- o *Be careful not to pinch the plastic tank cover bracket between the frame and the steering damper bracket when installing and tightening the new bolts.*

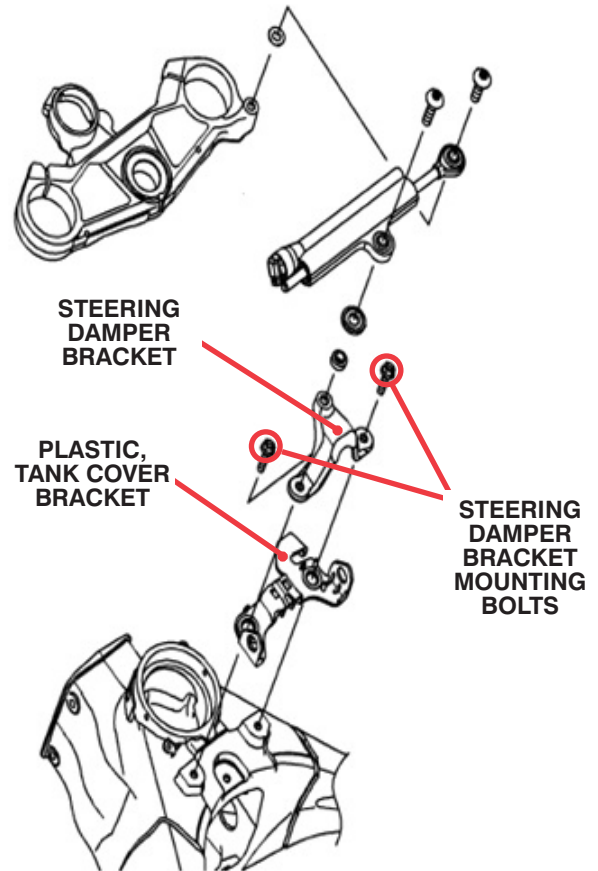

- Tighten the right bolt to 71 in•lb (0.82 kgf•m, 8.0 N•m) while pressing down on the center of the steering damper bracket while moving the steering damper bracket from side to side.
- Tighten the left bolt to 71 in•lb (0.82 kgf•m, 8.0 N•m).
- Tighten the right bolt again to 71 in•lb (0.82 kgf•m, 8.0 N•m).
- Install the fuel tank covers (three pieces) as outlined on pages 15-17 & 15-18 of service manual 99924-1509-01.
- Install the seats.

Parts Information

Both steering damper bracket mounting bolts must be replaced on all eligible units

Order parts to complete the Recall through K-Dealer as outlined in Service Bulletin SP15-03.

Bolt Kit, 99999-0569

KIT CONTENTS	QTY
Bolts	2

NOTE:

- o Use VIP in K-Dealer to identify affected units in your dealership inventory to order repair kits for unsold units

Warranty Information

This is a safety Recall campaign. Repair is authorized regardless of ownership or warranty status.

Repairs MUST BE PERFORMED IMMEDIATELY ON ALL ELIGIBLE UNITS in the field and during initial assembly and preparation.

See the Warranty Policies and Procedures Manual (claim type 3 information) for detailed instructions when submitting the Warranty Claim.

WARRANTY INFORMATION

Job Code	22480
Flat Rate Time	0.3 hr.
Claim Type	3
Part Number	99999-0569
Description	Bolt Kit
Qty	1

Repair Verification

Make a punch mark on the right rear frame as shown for repair verification.

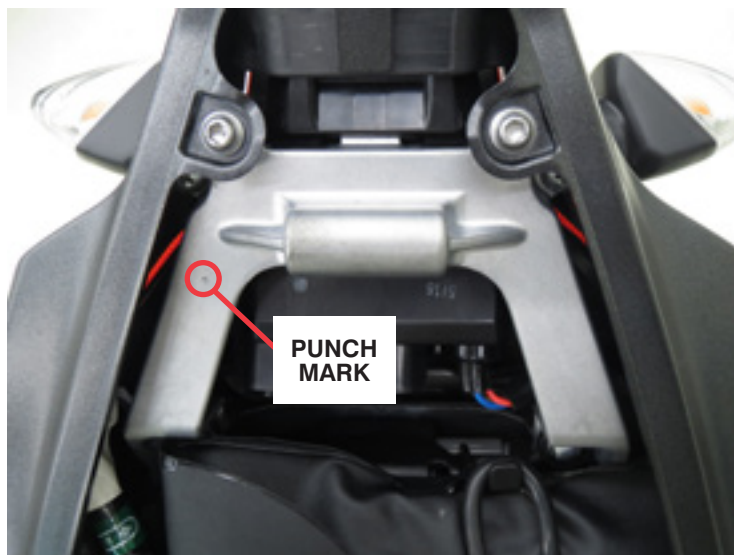

NOTE:

- o Repair verification is an essential part of the repair procedure. Along with the physical repair verification mark, check VIP (Vehicle Information Portal) in K-Dealer for other possible repair campaigns for eligible units.

2016 Ninja® ZX™-10R/10R ABS STEERING DAMPER BRACKET MOUNTING BOLTS IMPORTANT SAFETY RECALL

Dear Kawasaki Motorcycle Owner:

This notice is sent to you in accordance with the National Traffic and Motor Vehicle Safety Act. Kawasaki Motors Corp., U.S.A., has decided that a defect which relates to motor vehicle safety exists in certain 2016 Ninja® ZX™-10R/10R ABS motorcycles.

The reason for this notice:

Kawasaki has initiated a voluntary safety Recall Campaign to replace the steering damper bracket mounting bolts on certain 2016 Ninja ZX-10R/10R ABS.

On eligible units, the steering damper bracket mounting bolts could break due to over tightening during assembly causing the steering damper bracket to detach from the frame. The unfastened steering damper bracket could result in steering interference creating the potential for a crash resulting in injury or death.

What Kawasaki and your dealer will do:

In the interest of your continued satisfaction, Kawasaki has authorized your dealer to replace the steering damper bracket mounting bolts free of charge. The actual repair will take up to 30 minutes but may take longer due to scheduling at the dealership and the time needed to obtain required parts.

What should you do to ensure your safety?

Please call your Kawasaki dealer to schedule an appointment to have your 2016 Ninja ZX-10R/10R ABS repaired. Please have your Vehicle Identification Number (VIN) ready when calling.

DO NOT RIDE YOUR MOTORCYCLE UNTIL THE REPAIR HAS BEEN COMPLETED.

If you need help:

If you have questions or concerns that your dealer is not able to resolve, please contact Kawasaki's Consumer Services Department at (866) 802-9381 (toll-free) between 7:30 a.m. and 4:30 p.m. PT Monday through Friday. Please have your Vehicle Identification Number ready when calling.

If your dealer fails or is unable to remedy this defect without charge within a reasonable amount of time (60 days after your first attempt to obtain remedy), you may submit a written complaint to the Administrator, National Highway Traffic Safety Administration, 1200 New Jersey Ave. S.E., Washington, D.C. 20590, or call the toll-free Vehicle Safety Hotline at 1(888) 327-4236 (TTY: 1-800-424-9153); or go to <http://www.safercar.gov>.

If you received this notice in error:

Our records indicate you are the current owner of the 2016 Ninja ZX-10R/10R ABS described in this letter. If you no longer have the vehicle described in this letter, please help us to update our records at www.kawasaki.com by clicking on "OWNER CENTER => OWNER SUPPORT => UPDATE OWNER INFO" or by calling Kawasaki toll free at (866) 802-9381. Federal regulation requires that any vehicle lessor receiving this recall notice must forward a copy of this notice to the lessee within ten days.

Reimbursement:

If you have experienced the failure described above prior to receiving this letter and have paid to have it corrected, you may be eligible for full or partial reimbursement for your documented cost of repair(s). To apply for reimbursement, please send copies of current owner and VIN information along with copies of repair orders and payment confirmation to the following address:

Kawasaki Motors Corp., U.S.A.
ATTN: Consumer Services Department
P.O. Box 25252
Santa Ana, California 92799-5252

Please note the following conditions for reimbursement:

- Only repairs specifically related to this recall are eligible for reimbursement. Other expenses such as towing, rental, and accommodations will not be refunded.
- Claims may be excluded if proper documentation is not included. Current owner and VIN information along with copies of repair orders and payment confirmation must be provided.

We are sorry for any inconvenience this may cause, but we have taken this action in the interest of your safety and your continued satisfaction with your Kawasaki motorcycle.

Sincerely,

Kawasaki Motors Corp., U.S.A.