

TECHNICAL INSTRUCTIONS
FOR
CAMPAIGN G0C
CENTER AIRBAG SENSOR ASSEMBLY (SRS ECU)
CERTAIN 2003 - 2006 MY LAND CRUISER

Updated 11-21-17

Update 11-21-17

- **Parts information updated**

Update 03-24-17

- **Part information added and additional safety warnings**

The repair quality of covered vehicles is extremely important to Toyota. All dealership technicians performing this repair are required to successfully complete the most current version of the E-Learning course "Safety Recall and Service Campaign Essentials". To ensure that all vehicles have the repair performed correctly; technicians performing this repair are required to currently hold at least one of the following certification levels:

- **Toyota Expert Electrical**
- **Master Technician**
- **Master Diagnostic Technician**

Always check which technicians can perform the recall remedy by logging on to <https://www.uotdealerreports.com>. It is the dealership's responsibility to select technicians with the above certification level or greater to perform this repair. Carefully review your resources, the technician skill level, and ability before assigning technicians to this repair. It is important to consider technician days off and vacation schedules to ensure there are properly trained technicians available to perform this repair at all times.

I. OPERATION FLOW CHART

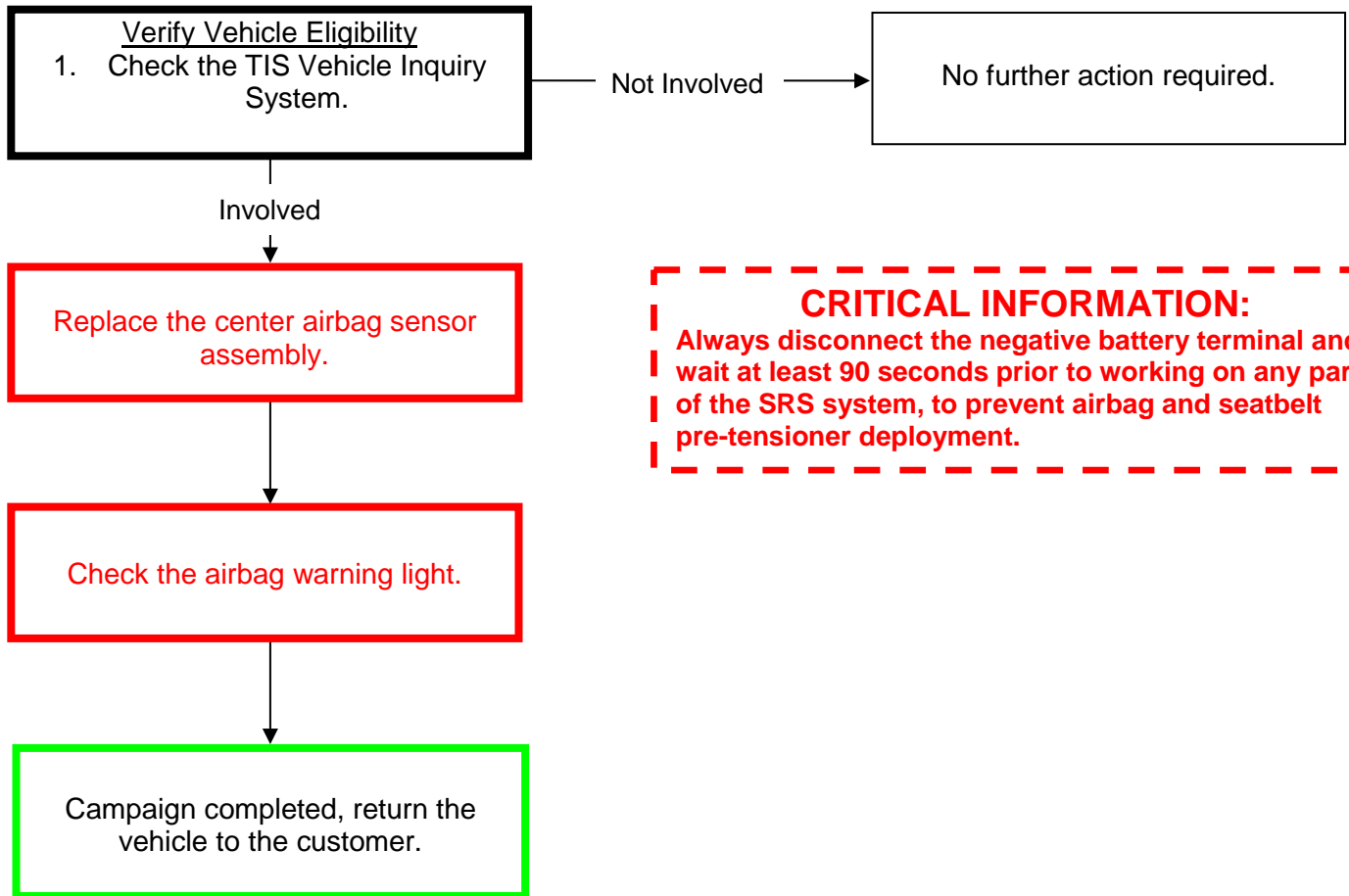

II. IDENTIFICATION OF AFFECTED VEHICLES

- Check the TIS Vehicle Inquiry System to confirm the VIN is involved in this SSC and that the campaign has not already been completed prior to dealer shipment or by another dealer.
- TMS warranty will not reimburse dealers for repairs conducted on vehicles that are not affected or were completed by another dealer.

III. PREPARATION

A. PARTS

NOTE: Only one Air bag sensor is needed per vehicle. To determine which part number to order, input the VIN into the following website: <https://g0c-glb-parts-lookup.imagespm.info/>. Default password is xxxxx.

B. TOOLS & EQUIPMENT

- Techstream
- Molding Remover Set
- Torque Wrench
- Standard Hand Tools

IV. BACKGROUND

The subject vehicles are equipped with side Curtain-Shield-Airbags (CSAs) which deploy from the roof rails in the event of certain types of crashes. Due to improper programming in the airbag control module, there is a possibility that, under certain specific and limited conditions shortly after vehicle startup, the CSAs and seat belt pre-tensioners could activate when not necessary. Unexpected activation of the CSAs could increase the risk of injury to the occupant.

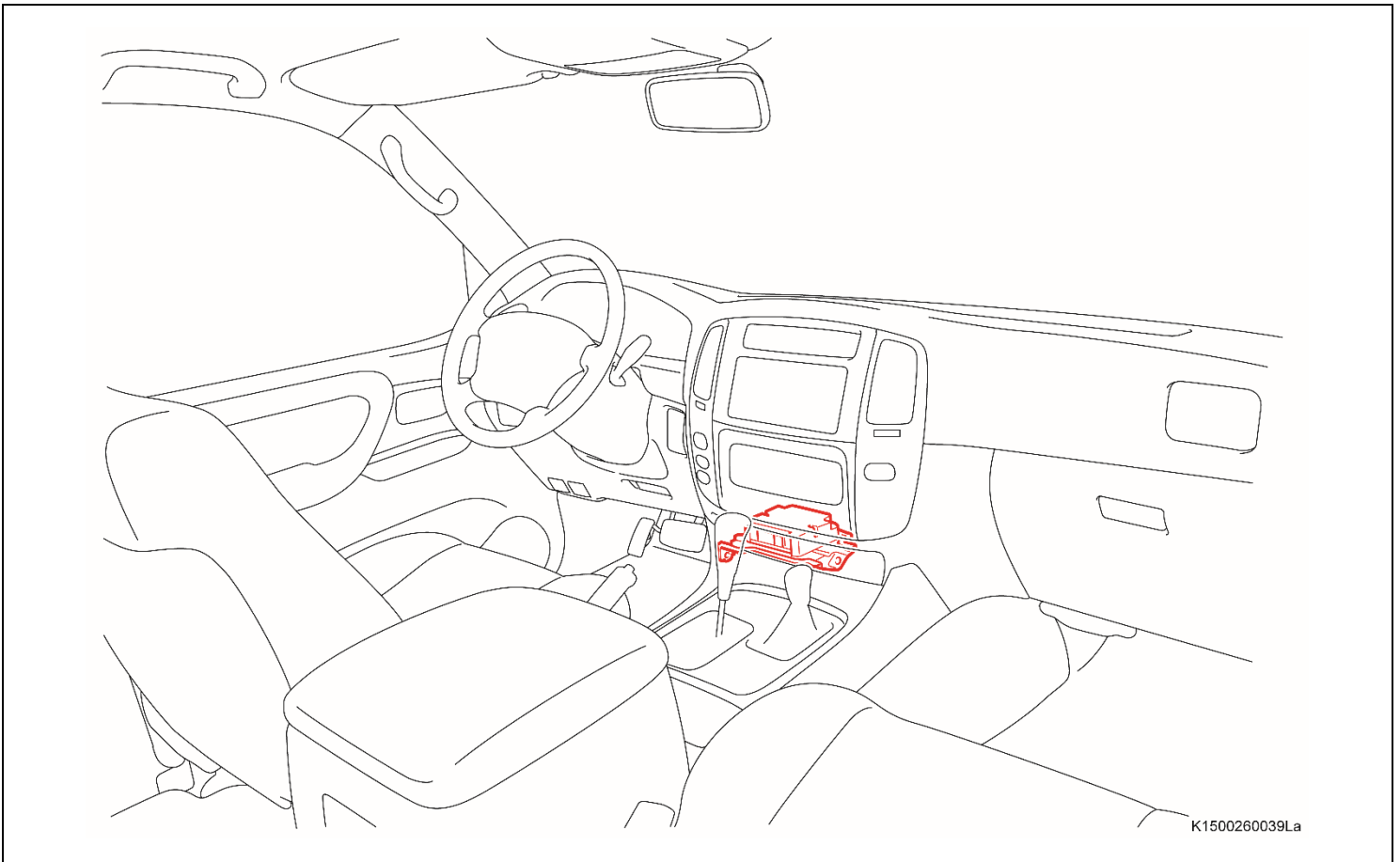

V. SAFETY PRECAUTIONS



CRITICAL INFORMATION – READ THOROUGHLY



The airbag system shall be installed / removed properly with correct procedure and method. Otherwise it could be deployed erroneously, resulting in a fatal accident.

Also, performing a wrong operation could result in inoperability of the system when needed.

So, please be sure to perform operation safely and securely by following to this Technical Instructions.

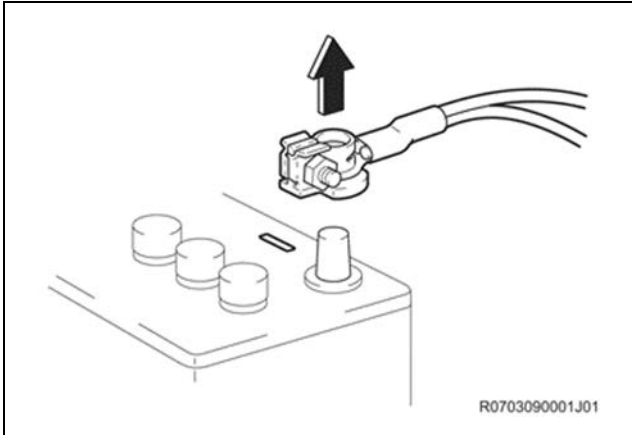

1. DISCONNECT THE BATTERY TERMINAL



- Always disconnect the negative terminal and wait 90 seconds before performing work to prevent airbag and seatbelt pre-tensioner deployment due to back-up battery supply.

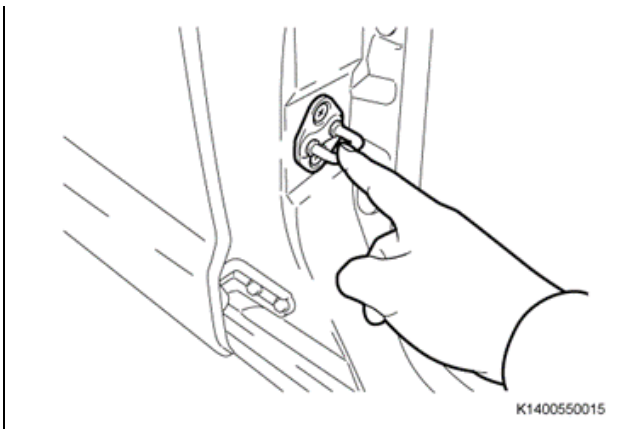

2. ELIMINATE STATIC ELECTRICITY

- a) Before removing ECU ground yourself by touching a metallic part of the vehicle.



3. DO NOT DROP THE CENTER AIRBAG SENSOR

NOTE: DO NOT use power or pneumatic tools to remove the fasteners that secure the sensor to the vehicle.

REPLACING THE CENTER AIRBAG SENSOR

1. PERFORM A HEALTH CHECK

- a) Check to verify if there any air bag DTC's present (current, history, or pending).



This campaign only covers the replacement of the Airbag Sensor Assembly (SRS ECU). No other components in the SRS system are covered by this campaign.

2. RECORD AND DOCUMENT CUSTOMERS VEHICLE SETTINGS

3. DISCONNECT THE NEGATIVE BATTERY TERMINAL



- Wait at least 90 seconds after disconnecting the cable from the negative battery terminal to prevent airbag and seat belt pre-tensioner deployment.
- Follow all precautions as outlined on TIS before servicing the SRS system.

4. COMPONENTS INVOLVED IN THE REMOVAL OF THE CENTER AIRBAG SENSOR

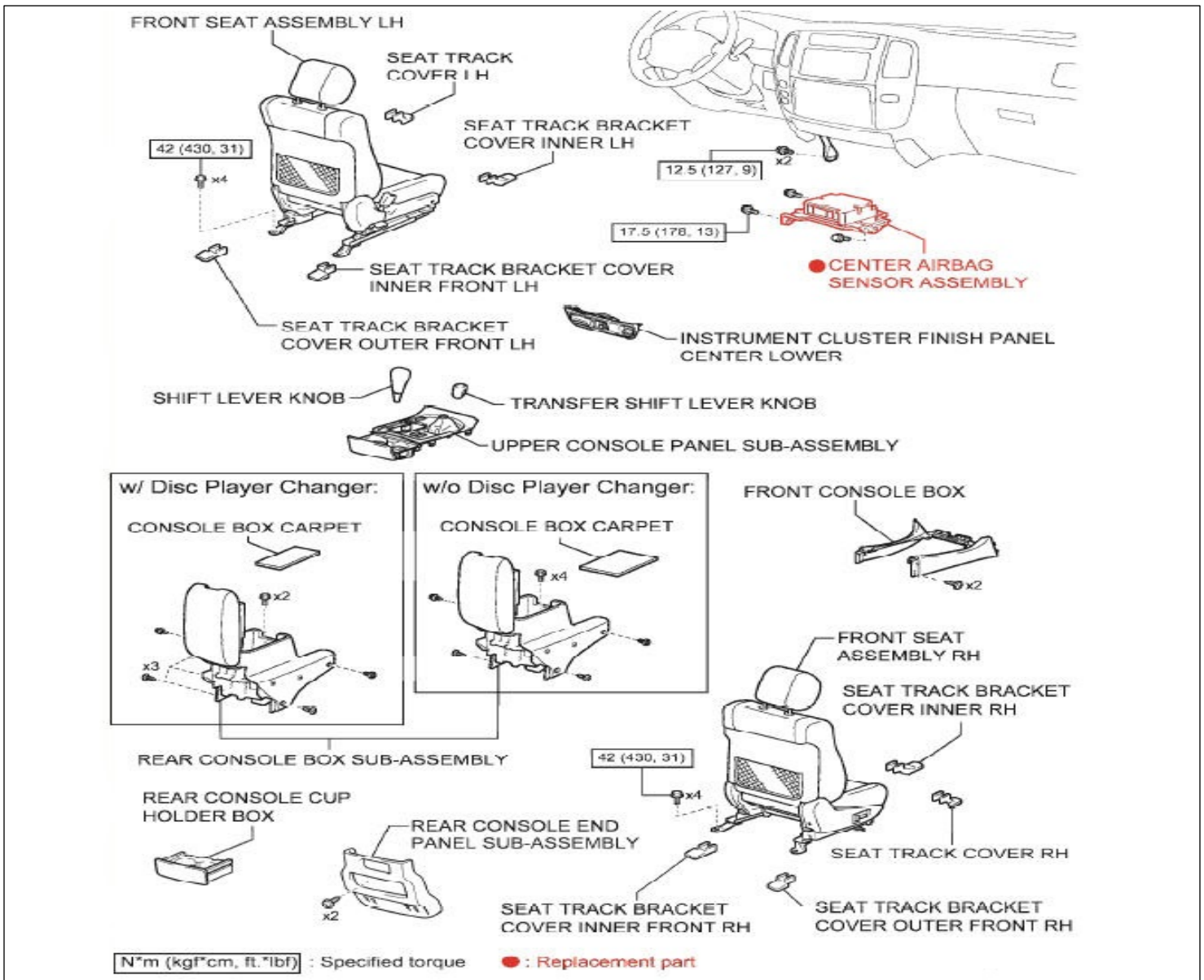

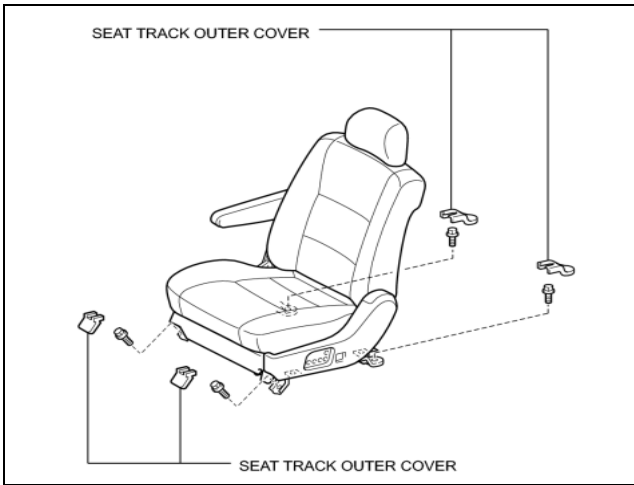

5. REMOVE SEAT TRACK OUTER COVER

- a) Using a screwdriver, detach the claws and remove the 4 covers.

6. REMOVE FRONT LH SEAT

- a) Remove the 4 bolts.
- b) Disconnect the connectors and remove the seat.

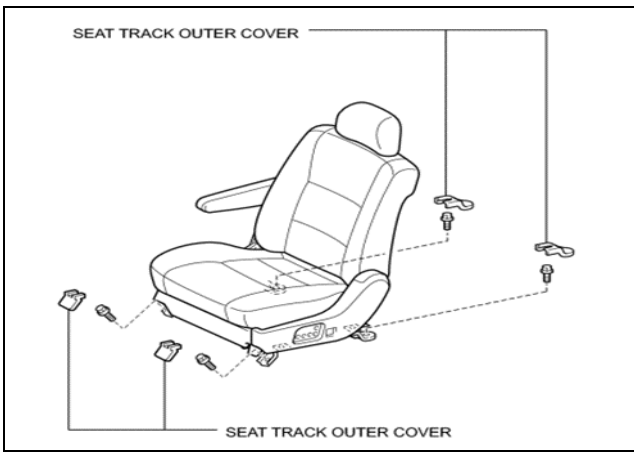

7. REMOVE SEAT TRACK OUTER COVER

- a) Using a screwdriver, detach the claws and remove the 4 covers.

8. REMOVE FRONT RH SEAT

- a) Remove the 4 bolts.
- b) Disconnect the connectors and remove the seat.

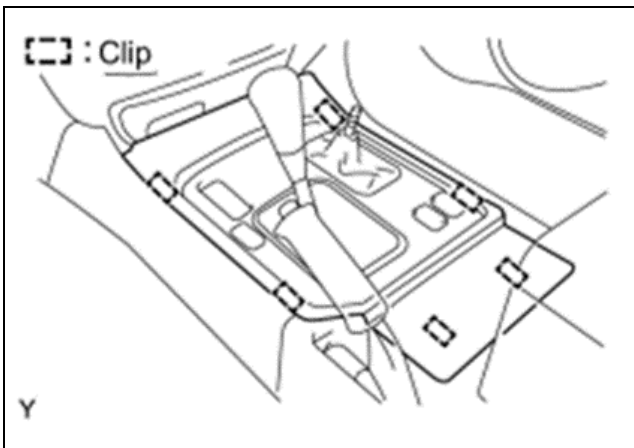

9. REMOVE THE TRANSFER SHIFT LEVER

10. REMOVE CONSOLE PANEL UPPER

- a) Remove the transfer shift lever knob.
- b) Using a screwdriver, detach the 2 clips and remove the end panel.

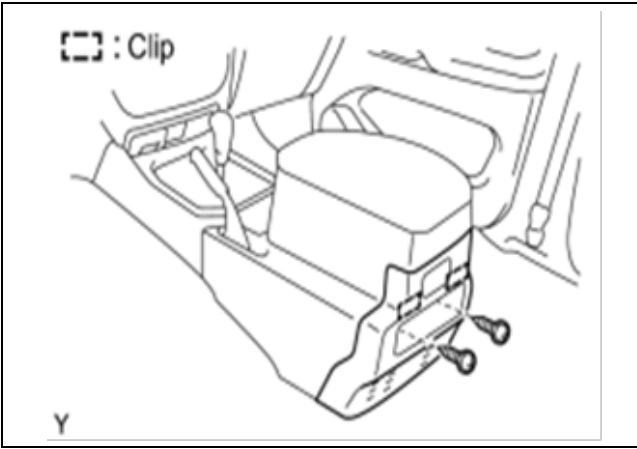

11. REMOVE REAR CONSOLE END PANEL

- a) Remove the transfer shift lever knob.
- b) Using a screwdriver, detach the 2 clips and remove the end panel.

12. REMOVE REAR CONSOLE BOX

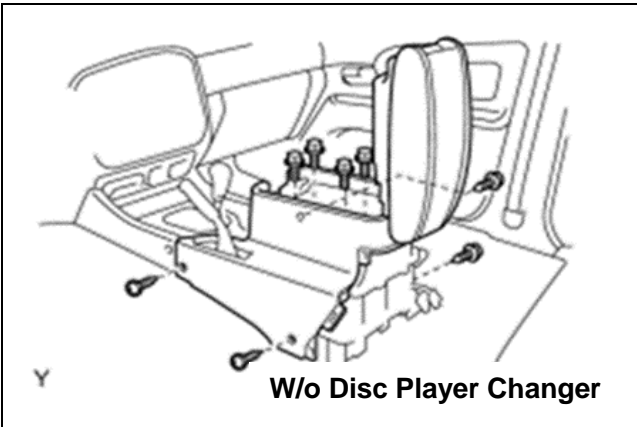

**13. REMOVE THE REAR CONSOLE BOX
(W/o Disc Player)**

- a) Remove the 4 bolts, 4 screws.

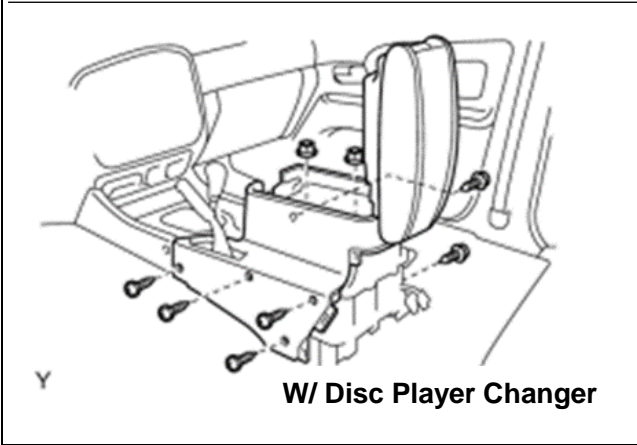

(W/ Disc Player)

- a) Remove the 2 bolts, 6 screws.

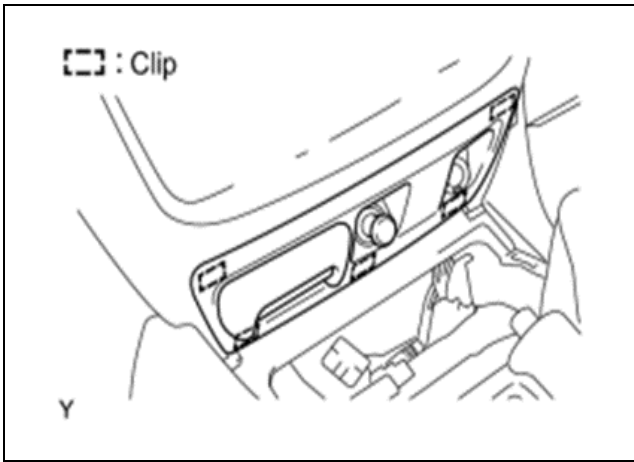

14. REMOVE INSTRUMENT CLUSTER FINISH PANEL CENTER LOWER

- a) Using a screwdriver, detach the 5 clips and remove the cluster finish panel, then disconnect the connectors.

NOTE: Tape the screwdriver tip before use.

15. REMOVE FRONT ASH RECEPTACLE RETAINER

- a) Remove the ash receptacle box.
- b) Remove the 2 screws and ash receptacle retainer.

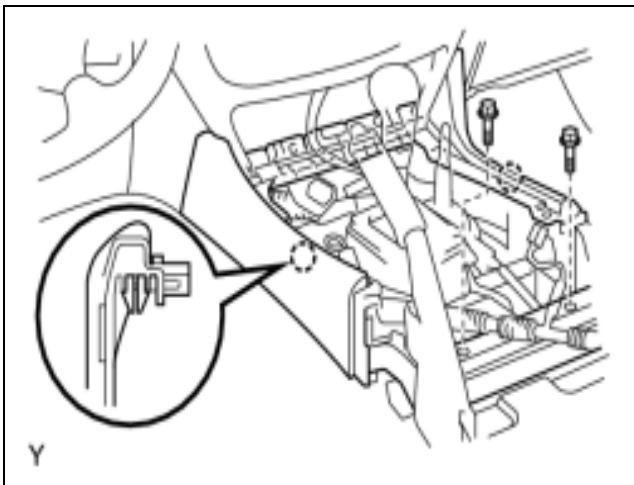

16. REMOVE FRONT CONSOLE BOX

- a) Remove the 2 bolts, console box and No. 4 console box mounting bracket.

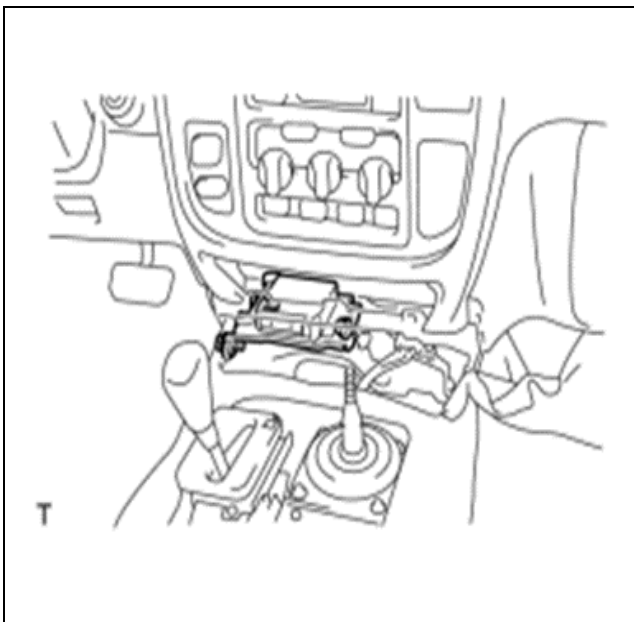

17. REMOVE THE CENTER AIRBAG SENSOR



- Confirm that the negative battery terminal is disconnected before performing the operation. Even an impact to only the airbag sensor will cause the airbag to deploy.
- Wait at least 90 seconds after disconnecting the negative battery terminal to prevent airbag and seat belt pre-tensioner deployment.

- a) Disconnect the 3 connectors from the center airbag sensor.
- b) Remove the 3 bolts and the center airbag sensor.

NOTE: DO NOT use power or pneumatic tools to remove the fasteners that secure the sensor to the vehicle.

VII. INSTALLATION OF THE NEW CENTER AIRBAG SENSOR

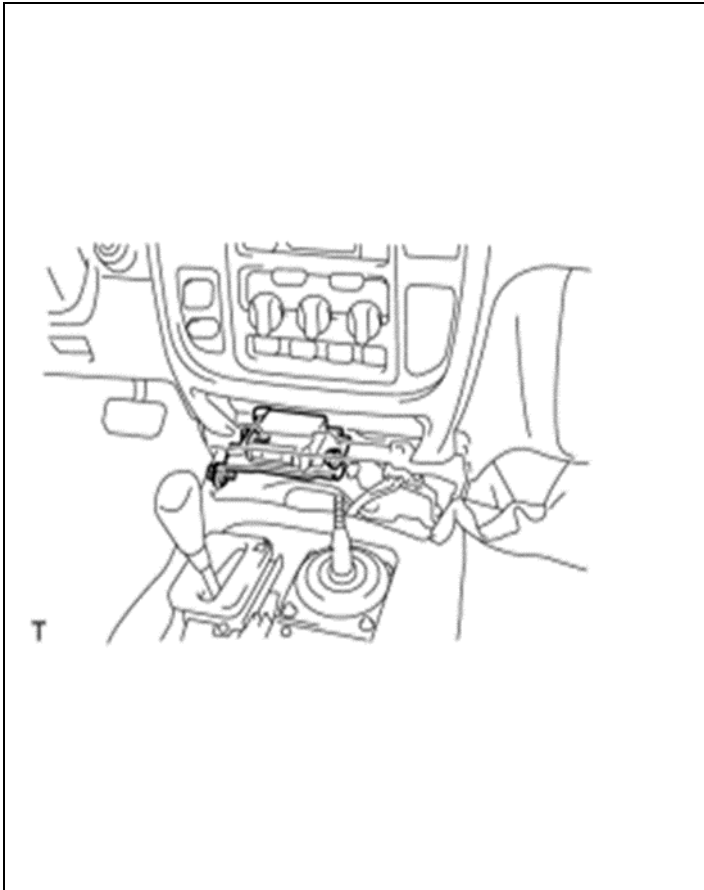

1. INSTALL CENTER AIRBAG SENSOR

- a) Check that the ignition switch is off.

NOTE: Verify that the campaign p/n and the sensor p/n match up. Always order the 04006-xxxxx p/n for vehicles covered by this campaign.

Campaign PN	Sensor PN
04006-26160	89170-60152
04006-26460	89170-60262
04006-26560	89170-60282

DO NOT use power or pneumatic tools to install the fasteners that secure the sensor to the vehicle.

- b) Install the center airbag sensor with the 3 bolts.
- c) Tighten the 3 bolts to the specified torque.
Torque: 17.5 N·m {179kgf·cm, 13ft·lbf }
- d) Connect the airbag sensor connectors.

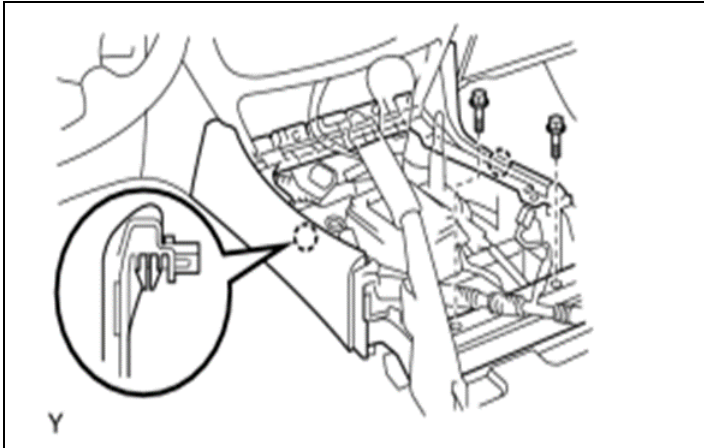

2. REINSTALL FRONT CONSOLE BOX

- a) Reinstall the 2 bolts, console box and No. 4 console box mounting bracket.

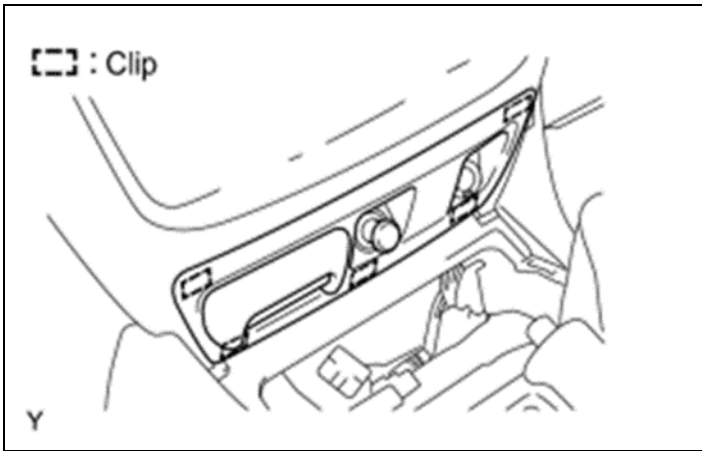

3. REINSTALL INSTRUMENT CLUSTER FINISH PANEL CENTER LOWER

- a) Reconnect the connectors then, attach the 5 clips and reinstall the cluster finish panel.

4. REINSTALL FRONT ASH RECEPTACLE RETAINER

- a) Reinstall the ash receptacle box.
- b) Reinstall the 2 screws and ash receptacle

5. REINSTALL REAR CONSOLE BOX (w/o Disc Player)

- a) Reinstall the 4 bolts, 4 screws.



(w/ Disc Player)

- a) Reinstall the 2 bolts and 6 screws.

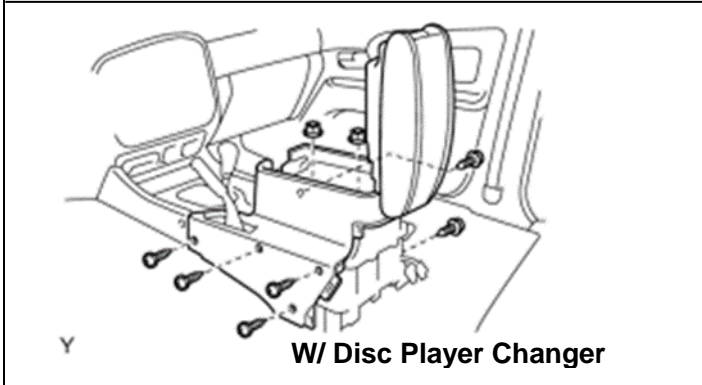

6. REINSTALL REAR CONSOLE END PANEL

- a) Reinstall the rear console cup holder box.
- b) Reinstall the 2 screws.
- c) Reattach the 2 clips and reinstall the end panel.

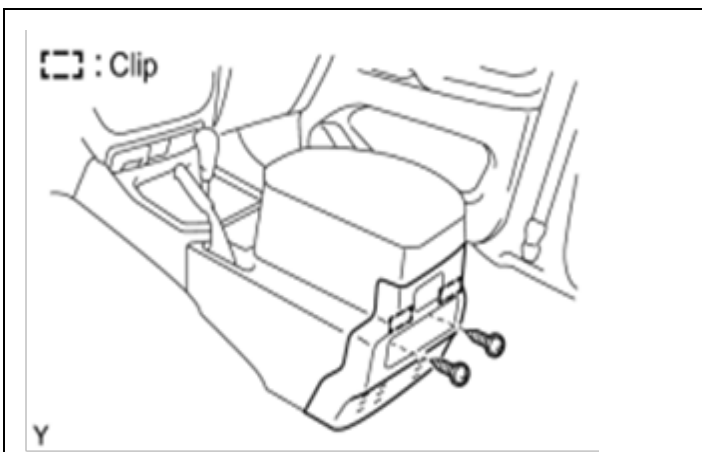

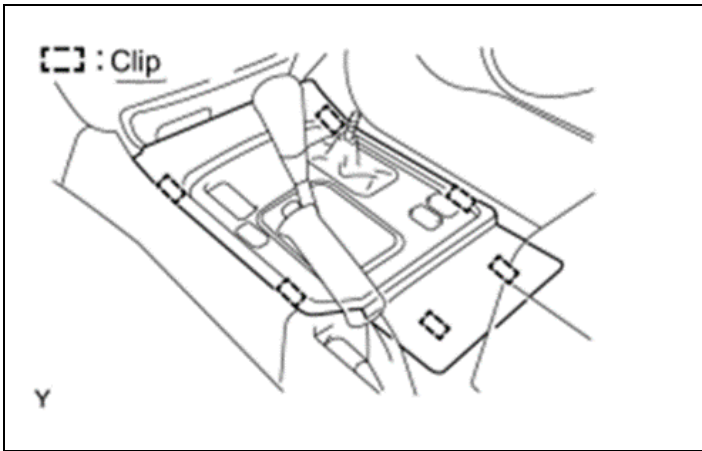

7. REINSTALL CONSOLE PANEL UPPER

- a) Attach the 2 clips and reinstall the console panel upper.

8. REINSTALL TRANSFER SHIFT LEVER

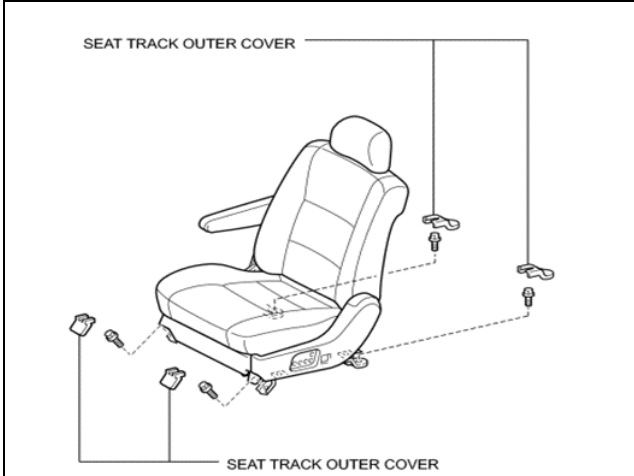

9. REINSTALL FRONT LH SEAT

- a) Reconnect the connectors

Torque:

42 N·m {430 kgf·cm, 31ft·lbf}

- b) Reinstall the 4 bolts.

10. REINSTALL SEAT TRACK OUTER COVERS

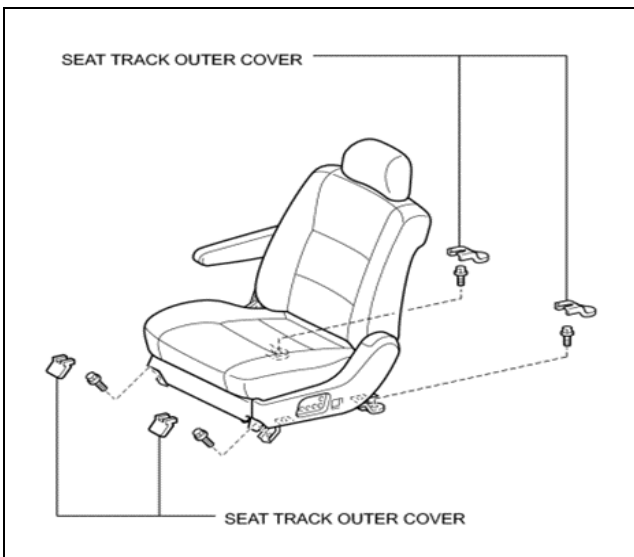

11. REINSTALL FRONT RH SEAT

- a) Reconnect the connectors.

Torque:

42 N·m {430 kgf·cm, 31ft·lbf}

- b) Reinstall the 4 bolts.

12. REINSTALL SEAT TRACK OUTER COVERS

NOTE: Seats equipped with OCS will need Zero Point Calibration and Sensitivity Check performed.

Refer to the Technical Information System (TIS), using the applicable vehicle and model year.

13. RECONNECT THE NEGATIVE BATTERY TERMINAL AND PERFORM ANY NEEDED INITIALIZATIONS

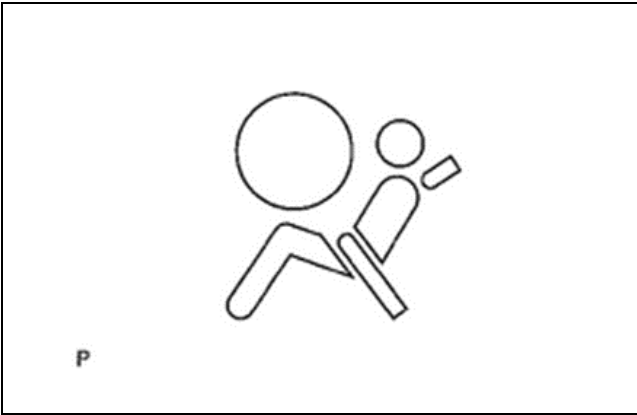

14. INSPECT SRS WARNING LIGHT

- a) Turn the ignition switch to the ON position, and check that the SRS warning light comes on for approximately 6 seconds (primary check).
- b) Check that the SRS warning light goes off approximately 6 seconds after the ignition switch is turned to the ON position (constant check).

◀ VERIFY REPAIR QUALITY ▶

- Ensure a Zero Point Calibration and Sensitivity Check is performed with vehicles equipped with OCS.

If you have any questions regarding this update, please contact your area representative.

VI. APPENDIX

A. CAMPAIGN DESIGNATION DECODER

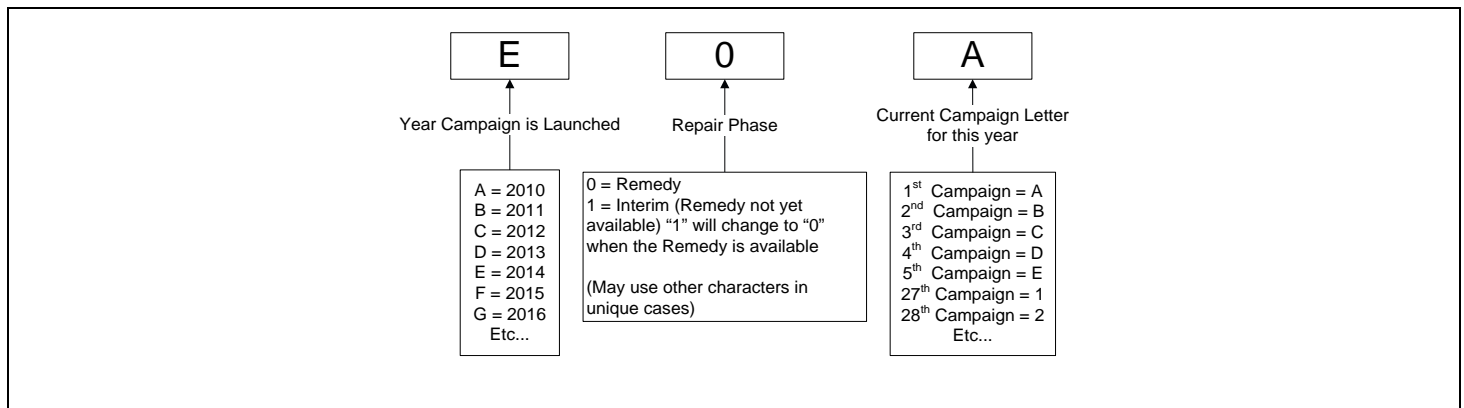

Examples:

A0D = Launched in 2010, Remedy Phase, 4th Campaign Launched in 2010
 C1B = Launched in 2012, Interim Phase, 2nd Campaign Launched in 2012
 E0A = Launched in 2014, Remedy Phase, 1st Campaign Launched in 2013

B. CAMPAIGN PARTS DISPOSAL

As required by Federal Regulations, please make sure all campaign parts (original parts) removed from the vehicle are disposed of in a manner in which they will not be reused, ***unless requested for parts recovery return.***