

**January 27, 2016**

03120 Version 3

**Safety Recall: 2008–10 Accord SRS Unit Replacement**Supersedes 16-006, dated January 26, 2016 to revise the information highlighted in **yellow****AFFECTED VEHICLES**

Year	Model	Trim	VIN Range
2008–10	Accord	4-Door	Check the iN VIN status for eligibility

**REVISION SUMMARY**

Under WARRANTY CLAIM INFORMATION, there were changes to clarify that the serial number of the new SRS unit must be included in the warranty claim and the inspection is for cases where the SRS indicator is on only.

**BACKGROUND**

An internal component in the SRS unit may be susceptible to corrosion, potentially resulting in the SRS unit failing. If the SRS unit fails, the SRS indicator comes on. If the vehicle is involved in a collision and the SRS indicator is on because of the SRS unit failure, the airbags will not deploy, increasing the risk of injury.

**CUSTOMER NOTIFICATION**

Owners of affected vehicles will be sent a notification of this campaign.

Do an iN VIN status inquiry to make sure the vehicle is shown as eligible.

Some vehicles affected by this campaign may be in your used vehicle inventory. These vehicles must be repaired before they are sold.

Should your dealership sell an unrepaired vehicle that subsequently causes injury or damage because of the recalled item, the dealership will be solely responsible to the damaged party, and will be required to defend and indemnify American Honda for any resulting claims. To see if a vehicle in inventory is affected by this recall, do a VIN status inquiry before selling it.

**CORRECTIVE ACTION**

Inspect the SRS unit to determine if it already has failed due to the recall issue (DTC[s] 51-XX, 53-XX, U0151 or no HDS communication with HDS). If it already has failed due to the recall issue, replace the SRS unit. If the SRS unit still is operational, inform the customer that they will be notified when parts are available to replace operational SRS units, but to immediately come back in if the SRS indicator comes on.

**PARTS INFORMATION**

Part Name	Part Number Ordered	You may receive any of the following	Quantity
SRS Unit	77960-TA0-A02	77960-TA0-A02 77960-TA0-L02	1
Torx Bolts	90137-S84-A01	N/A	3

**CUSTOMER INFORMATION:** The information in this bulletin is intended for use only by skilled technicians who have the proper tools, equipment, and training to correctly and safely maintain your vehicle. These procedures should not be attempted by "do-it-yourselfers," and you should not assume this bulletin applies to your vehicle, or that your vehicle has the condition described. To determine whether this information applies, contact an authorized Honda automobile dealer.

## WARRANTY CLAIM INFORMATION

### NOTE:

- If you replace the SRS unit, the replacement SRS unit ID (serial number) must be entered in the DTC field of the warranty claim.
- Enter the part number of the SRS unit that you received into the warranty claim, **not the part number that you ordered.**
- Do not file a warranty claim if the SRS indicator comes on and goes off after about 6 seconds because the vehicle is OK.
- To avoid non-payment of warranty claims, make sure the DTC is entered in the DTC field.

Operation Number	Description	Replacement Part Number	Flat Rate Time	Defect Code	Symptom Code	Template ID	Failed Part Number
7515A4	Inspect and replace the SRS unit. (Use this LON if you did your inspection in 15-078 and you were directed to 16-006 to replace the SRS unit).	77960-TA0-A02	1.1 hrs	6CN00	JW900	16-006A	77960-TA0-A01
7515A4		77960-TA0-L02	1.1 hrs	6CN00	JW900	16-006B	77960-TA0-A01
7515A5	Inspect the vehicle because SRS indicator is on to retrieve DTCs, but the DTC(s) are not covered by this recall.	No parts replaced.	0.3 hr	6CN00	JW900	16-006C	77960-TA0-A01

## INSPECTION PROCEDURE

1. Turn the ignition to ON and check if the SRS indicator comes on for about 6 seconds, then goes off.
  - If the indicator comes on, then goes off after about 6 seconds, the SRS unit and SRS is working. Have the customer return when they receive a notification that parts are available to replace the SRS unit or if the SRS indicator comes on.  
**NOTE: Do not file a warranty claim if the SRS is working. The inspection claim is for retrieving DTCs when the SRS indicator is on only.**
  - If the indicator does not come on, or if it stays on, go to step 2.
2. Connect the HDS and check for DTCs. Write the DTCs on the RO.
  - If any of the following DTCs are stored or the HDS does not communicate with the SRS unit, go to REPAIR PROCEDURE.
    - 51-XX
    - 53-XX
    - U0151
  - If there are SRS DTCs other than those listed above, do the following:
    - Contact the customer and inform them that there is a problem with the SRS and explain that the SRS unit may not be responsible for the problems causing the indicator to illuminate. The SRS unit replacement was only intended to address the specific problem that led to the recall.
    - If the customer declines the customer pay repairs, make sure you write down the description of the problem and any DTCs on the RO. Also indicate on the RO that the SRS is not operating properly and may pose a risk to the occupants in the event of a collision, either because the airbags may not deploy, or the airbags may deploy in a manner that does not account for all factors involved in the collision.
    - Inform the customer that when they receive a notification once parts are available, they may return to have the SRS unit replaced. After the SRS unit is replaced, additional customer pay repairs will likely be needed to return the SRS to proper operation.

## REPAIR PROCEDURE

1. Do the battery disconnection procedure, then wait at least 3 minutes before starting work.

NOTE: Make sure you have the anti-theft code for the audio system or the navigation unit and record the customer's audio unit presets.

2. Remove the driver's and front passenger's dashboard center lower cover.
  - Detach the clip by carefully pulling out the front edge of the console, then up to release the hooks from the dashboard.
  - Carefully pull out the front area of the console to allow room to access and remove clip No. 1.
  - Remove the dashboard center lower cover by releasing clip No. 2, then lift up to release the hook from the heater duct.

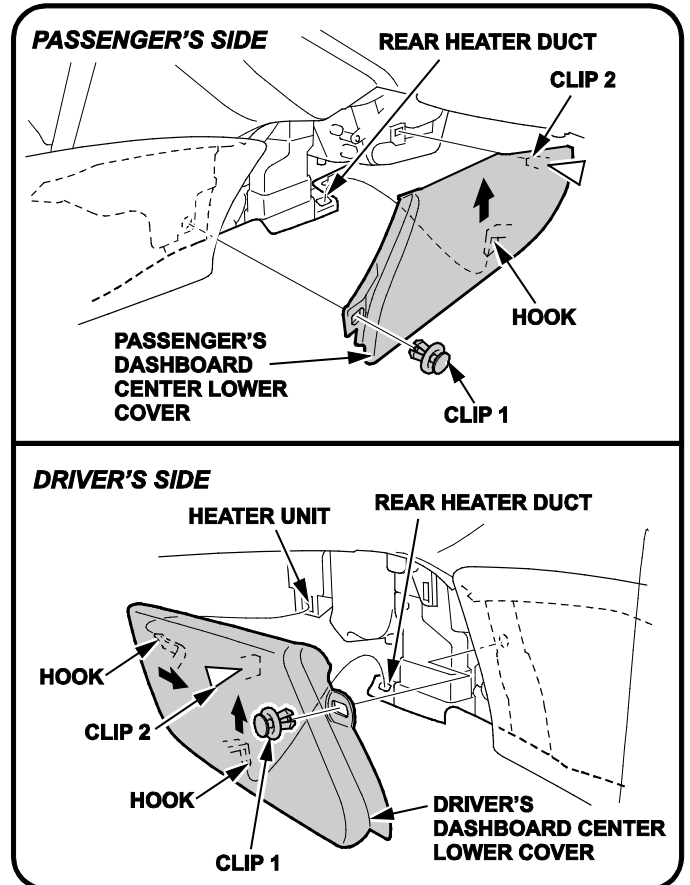
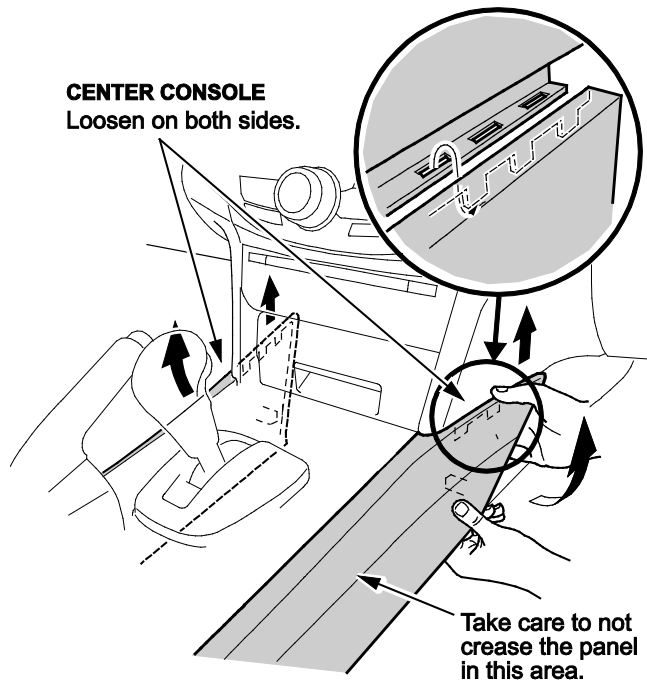

3. Remove the Torx bolt.

### DRIVER'S SIDE

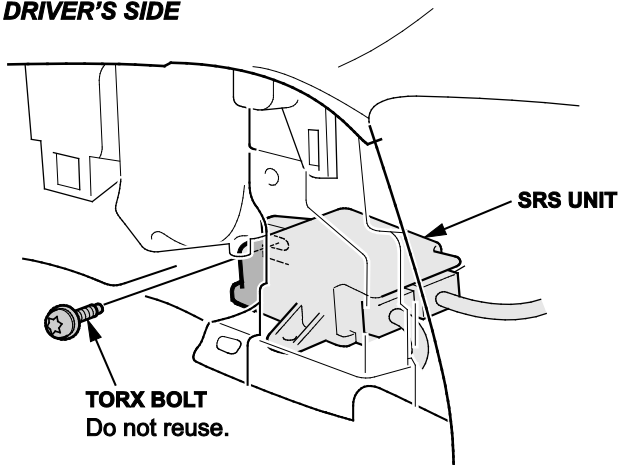

4. Remove the heater duct clip, then remove the heater duct.

**DRIVER'S SIDE**

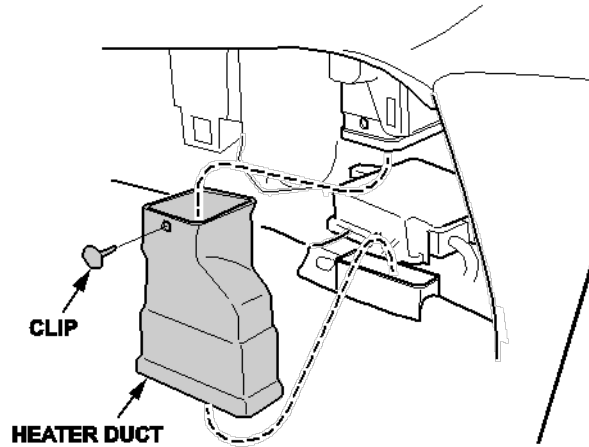

**PASSENGER'S SIDE**

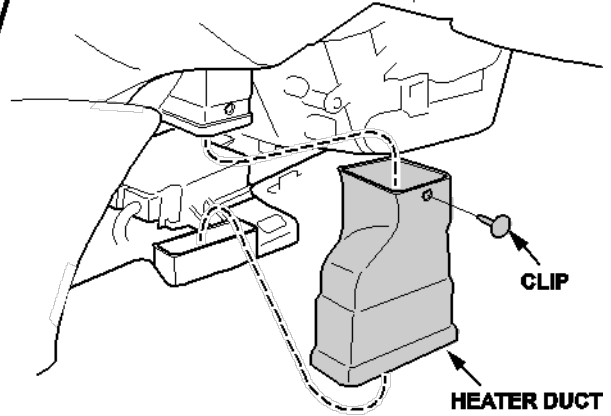

5. Disconnect the SRS unit connectors from the SRS unit by releasing the lever locks, then pull on the lever to disconnect the connectors.

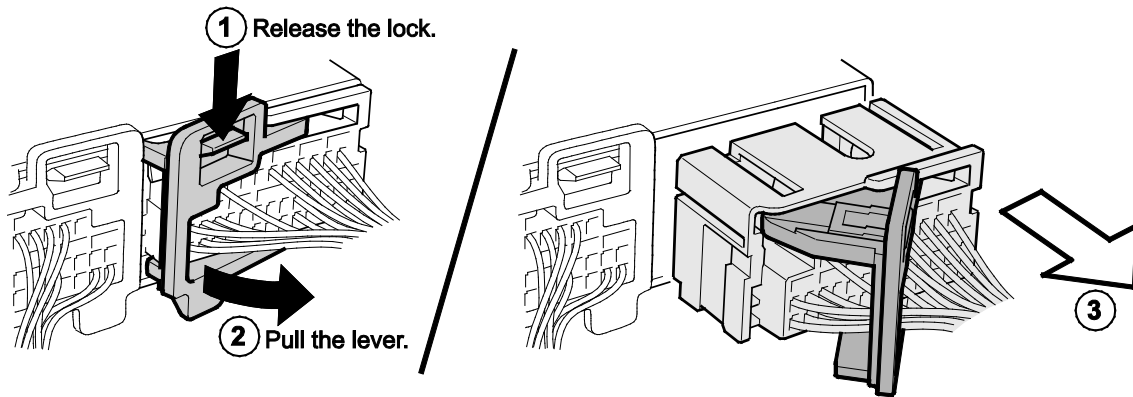

6. Remove the Torx bolts and remove the SRS unit.

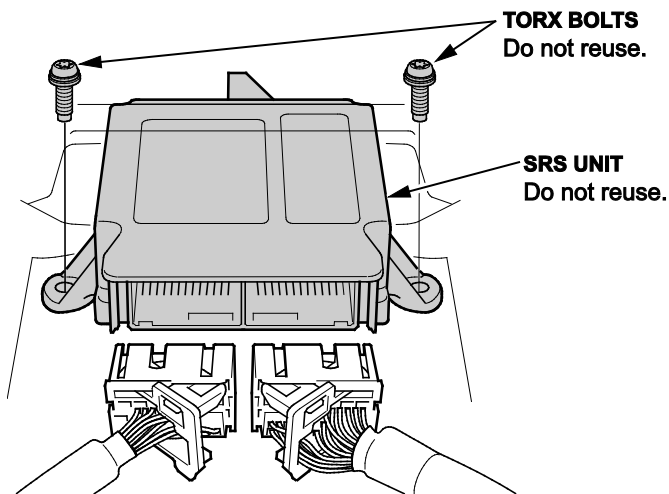

7. Write down the SRS unit ID (serial number) on the RO, then install the new SRS unit using the new Torx bolts.

NOTE: Make sure the SRS unit is sitting squarely against its bracket before torquing the Torx bolts.

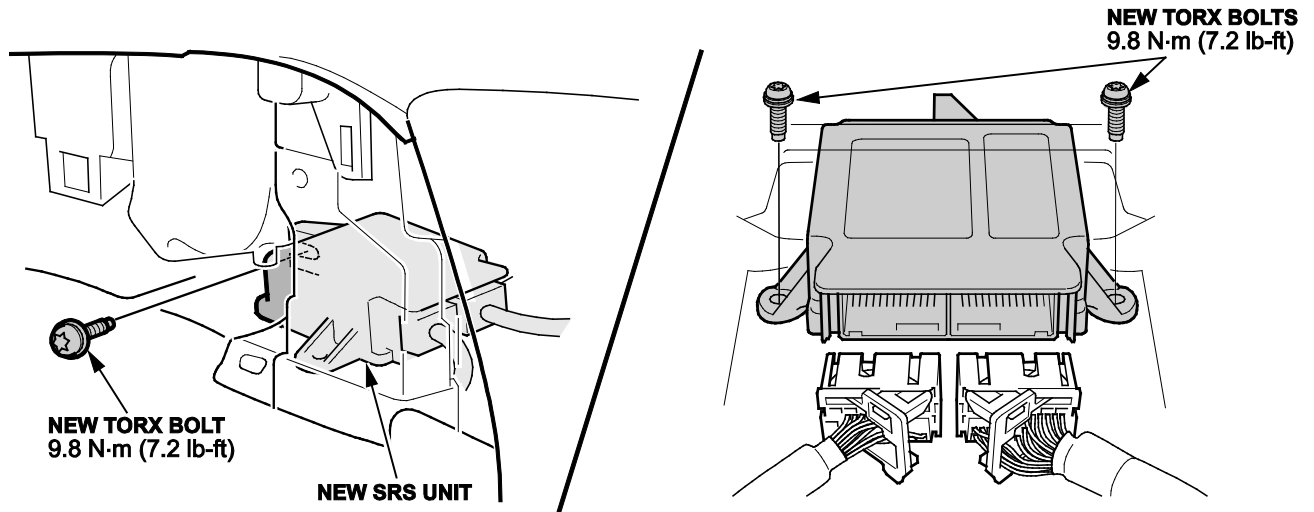

8. Connect the SRS connectors to the SRS unit by pushing the connector in and the lever moves to the locked position.

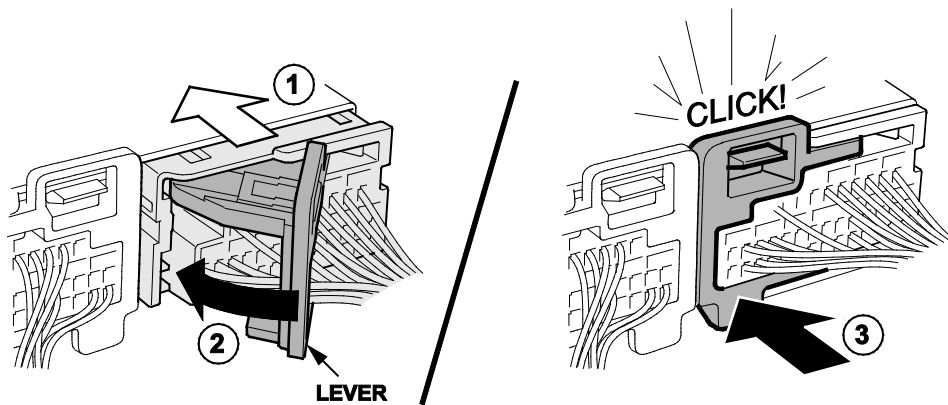

9. Do the battery terminal reconnection procedure.

10. Ready the vehicle for OPDS initialization by doing the following:

- Move the front passenger's seat-back to the most upright position.
- Slide the front passenger's seat all the way back.
- Make sure there is nothing in the front passenger's seat-back pocket.
- Make sure there is nothing under the front passenger's seat.
- Make sure the vehicle is parked out of direct sunlight.
- Make sure the vehicles temperature has stabilized to the shop temperature (do not initialize the vehicle in extreme cold or hot temperatures).

11. To complete SRS unit initialization, **turn the ignition to ON for 1 full minute, turn the ignition to OFF for another minute, then repeat two more times, making sure to wait 1 full minute between the ignition to ON or OFF.** After cycling the ignition 3 times, turn the ignition to ON and if the SRS indicator comes on for about 6 seconds then goes off, the SRS unit initialization is complete.

12. Enter the anti-theft codes for the audio and navigation system (if applicable), then enter the customer's audio unit presets.

13. *Vehicles without navigation:* Set the clock.

14. Reinstall all removed parts in the reverse order of disassembly.

15. Give your warranty clerk the RO that includes the stored DTC(s) and the replacement SRS unit serial number.

END