

Trailer Air Suspension Systems

Cast Beam Pivot Bolt Replacement Procedure

MAY 2014

Service repair kit SRK-710 has been supplied for the pivot bolt replacement. Each kit will do one axle and will include two (2) 93201070 pivot bolt, four (4) 93600553 outside washers, and two (2) 93400506 lock nut (**Figure 2**).

IMPORTANT: It is recommended that the trailer be unloaded before beginning service procedures.

1. On a level surface, support the front of the trailer with either a kingpin stand, landing gear, or coupled to a tractor.
2. Raise the trailer frame approximately 2" and support it with jack stands and remove wheel chocks.
3. At the suspensions specified ride height, place multiple jack stands under the vehicles frame per OEM specified locations, then lower the trailer frame onto the jack stands.

⚠ WARNING Failure to properly support the trailer during service procedures could create a crush hazard which, if not avoided, could result in death or serious injury.

4. Exhaust all air from the suspensions air bags, set the parking brakes, and chock the wheels.
5. Raise the trailer axle approximately 2" and support it with jack stands and remove wheel chocks.

⚠ WARNING Failure to properly support axle during a service procedure could create a crush hazard which, if not avoided, could result in death or serious injury.

6. Remove the tires.
7. On the roadside hangers, scribe or mark a line on the frame bracket outlining the position of the washers on both the inside and outside locations (**Figure 1**). These scribe marks will be used for ensuring previous alignment.
8. Starting on the curbside hangers, Remove 1-1/8" inch pivot bolt. (This is to be shipped back to SAF-HOLLAND®). Discard the old pivot nut and old washers.
9. Install new pivot hardware (**Figure 2**).

NOTE: On the roadside hangers while the connection is in a loose state, prior to final torque, ensure that the new washers are indexed back in place to where you made your scribe marks to ensure previous alignment.

Figure 1

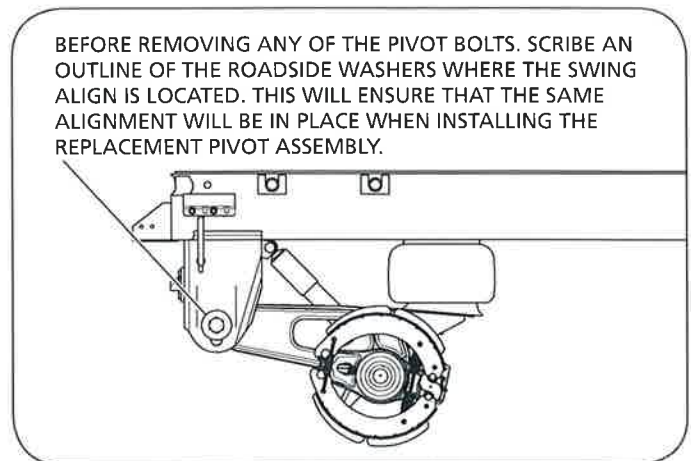
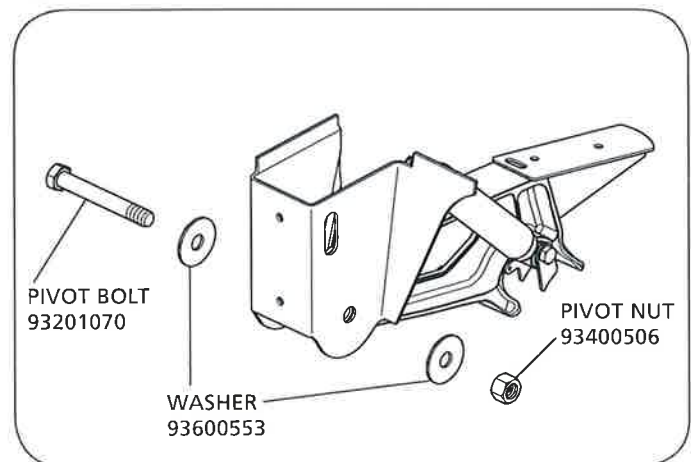

Figure 2



10. Torque the new pivot nut to a value of 550-600 ft.-lbs.
11. Clean the head of the bolt and add a white paint dot to indicate a change has been made.
12. Reinstall the tires.
13. Repeat this process for the pivot assembly hardware on the curbside of the suspension.
14. Lower the axle and tires onto the ground.
15. Repeat this procedure for the other suspensions affected.
16. Raise trailer approximately 2" and remove jack stands.
17. Air up the trailer suspension.



From fifth wheel rebuild kits to suspension bushing repair kits, SAF-HOLLAND Original Parts are the same quality components used in the original component assembly.

SAF-HOLLAND Original Parts are tested and designed to provide maximum performance and durability. Will-fits, look-alikes or, worse yet, counterfeit parts will only limit the performance potential and could possibly void SAF-HOLLAND's warranty. Always be sure to spec SAF-HOLLAND Original Parts when servicing your SAF-HOLLAND product.

SAF-HOLLAND USA • 888.396.6501 • Fax 800.356.3929

www.safholland.us

SAF-HOLLAND CANADA • 519.537.3494 • Fax 800.565.7753

WESTERN CANADA • 604.574.7491 • Fax 604.574.0244

www.safholland.ca

SAF-HOLLAND MEXICO • 52.55.5362.8743 • Fax 52.55.5362.8743

www.safholland.com.mx

info@safholland.com