



210 Inverness Center Drive  
Birmingham, AL 35242

Telephone: 205-991-7733  
Facsimile: 205-991-9993  
www.altec.com

## IMPORTANT SAFETY RECALL

**This notice applies to your vehicle. See attached serial number list.**

NHTSA Safety Recall No. 16V-835
------------------------------------

January 13, 2017

Dear Altec Owner,

This notice is sent to you in accordance with the National Traffic and Motor Vehicle Safety Act, and Canada Motor Vehicle Safety Act.

Altec Industries, Inc. has decided that a defect which relates to motor vehicle safety exists in certain AA500L, AA600L, AN755, AM650-855, and AS Series Units. Some specific units may have a lower boom lift cylinder that can fail when the lower boom is in the near vertical position. The cylinder failure can possibly cause uncommanded movement resulting in death or serious injury.

Refer to MAB 641 for the items covered under the warranty policy.

In order to determine if your unit is affected by MAB 641, compare the serial number of your unit with the list of affected units attached to the MAB. The repair can be performed by the customer or you may contact Altec at 1-877-GO-ALTEC (1-877-462-5832) for further assistance. The repair is expected to take 5.5 hours to complete.

At any time, you may contact Altec at 1-877 GO ALTEC (1-877-462-5832) with your unit's serial number to determine if there are any other outstanding notices.

For US owners: after contacting Altec, if you are still not able to have the safety condition remedied within a reasonable time, you may write to: Administrator, National Highway Traffic Safety Administration, 1200 New Jersey Avenue SE, Washington, DC 20590 or call 1-888-327-4236 (TTY: 1-800-424-9153) or go to <http://www.safercar.gov>.

For Canadian Owners: if you are still not able to have the safety condition remedied by your dealer within a reasonable time, please contact Altec Customer Service at 1-877-GO-ALTEC (1-877-462-5832).

If you had this repair performed before you received this letter, you may be eligible to receive reimbursement for the cost of obtaining a pre-notification remedy of the problem associated with this recall. If you have sold or retired the unit please call Altec at 1-877-GO-ALTEC (1-877-462-5832) so the records may be changed.

If you have leased this equipment to another person or company, you are required by Federal Law to forward a copy of this notice to the lessee by first class mail within ten (10) days of the receipt of this notice.

We are sorry to cause this inconvenience; however we are taking this action in the interest of your safety and continued satisfaction with Altec products.

Thank you for your immediate attention on this important matter.



Altec Industries, Inc.  
Midwest Division  
St. Joseph, MO

MAB 641

# MANDATORY ACTION BULLETIN

Date: January 13, 2017

Units Affected: AA500/AA600 Series, AN Series, AM650/855 Series, and AS Series  
(units built between 1995 and 1999, see attached list)

## Lower Boom Lift Cylinder Inspection

**This Mandatory Action Bulletin requires immediate action.**

This Mandatory Action Bulletin requires immediate inspection of the lower boom lift cylinder on specific units in the affected list. Altec has received a report of a cylinder failure when the lower boom is in the near vertical position. **Death or serious injury can result from uncommanded movement. The failure of the lower boom lift cylinder can cause death or serious injury.**

Investigation has determined that some lower boom lift cylinders have the potential for failure. Units affected must be immediately inspected for the specific cylinders. These cylinders can be identified by:

- A retaining cap on the head gland which is threaded to the outside of the cylinder barrel (refer to Figure 1). [If the cylinder is found to have the head gland threaded to the outside of the cylinder barrel but further information is needed, please contact Altec by dialing 1-877-GO-ALTEC (1-877-462-5832), prompt 4, Technical Support].

**If the cylinder has this identifying characteristic, the cylinder MUST be replaced. The lower boom operation must be limited to no more than 55 degrees of movement relative to the ground (refer to Figure 2) until the cylinder is replaced. Make sure that all operators or service technicians are aware of this restricted range of movement.**

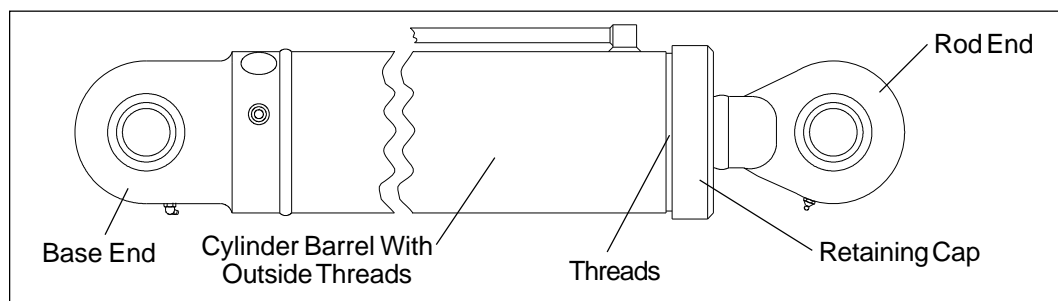

**Figure 1 — Cylinder With External Thread Retaining Cap**

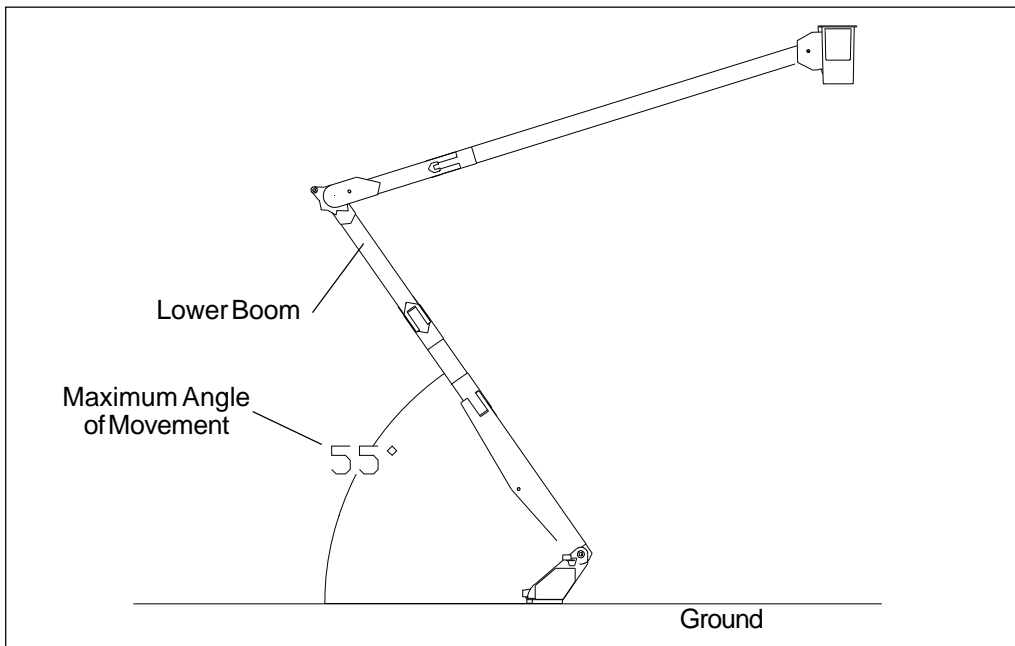

**Figure 2 — Lower Boom Movement Range**

If the cylinder does not have this specific design characteristic, the unit may be placed back into service. No further action is required for this Mandatory Action Bulletin.

After performing the inspection, complete the Inspection Sheet on Page 3 and fax it to the phone number as shown on the form.

Call 1-877-GO ALTEC (1-877-462-5832) to order the replacement cylinder kit from the chart below.

UNIT	KIT PART NUMBER
AA500/500L	970703885
AA600/600L	970703885
AN Series	970703885
AM650	970703886
AM855	970703886
AM855 Elevator	970703886
AS Series	970703884

This repair is covered under the Altec Warranty Policy and can be performed by Altec, the customer, or the customer’s warranty provider. Altec will allow up to \$495 for the labor to perform this repair. A warranty claim must be submitted to be reimbursed for the cost of the parts and/or labor. Call 1-877-GO ALTEC (1-877-462-5832) to schedule the work to be done by an Altec service technician. Customers are responsible for the travel costs of an Altec Mobile Service technician if the technician performs the inspection or repair at the owner’s location.

# MAB 641 Inspection Sheet

Complete this form and FAX to: 1-877-659-9929

Model	Serial Number	Cylinder Requires Replacement		Date Inspected
		Yes	No	

Make additional copies of this form, as needed, for additional units. Contact Technical Support at 1-877-GO ALTEC (1-877-462-5832), prompt 4, for further repair information.

Company Name: \_\_\_\_\_ Phone \_\_\_\_\_

Company Contact: \_\_\_\_\_

Company Street Address: \_\_\_\_\_

State: \_\_\_\_\_ ZIP Code: \_\_\_\_\_

Signature: \_\_\_\_\_