

SERVICE BULLETIN



UTILITY TRAILER MANUFACTURING CO.

SB-10-004

Issue date: September 20, 2016

NHTSA Reference # 16V674

IMPORTANT NON-COMPLIANCE EQUIPMENT RECALL NOTICE – Dealer Notification

AERO – RAD RECALL NOTICE

UTM Reference: **#414249**

Per Aero Industries this is to inform you that Utility Trailer Manufacturing Company notified the National Highway Traffic Safety Administration (NHTSA) of the start of a voluntary Non-Compliance campaign involving the Aero Conestoga XP with RAD style rear closure.

- Affected trailers include certain Conestogas with manufacturing year of 2015-2017 (66 Trailers)

Please refer to the Aero Guideline and Repair Procedure attached for complete details.

You should immediately contact Aero Industries to get your repair kits. If you have any questions regarding the information indicated, please contact Aero Industries directly at 1.800.535.7563

Field Service Department
UTILITY TRAILER MANUFACTURING COMPANY



IMPORTANT SAFETY RECALL NOTICE

This notice is sent to you in accordance with the National Traffic and Motor Vehicle Safety Act.

Aero Industries has decided that a defect which relates to motor vehicles safety exists in certain Conestoga XP systems with a RAD style rear closure.

IMPORTANT

- Your Conestoga XP with RAD style rear closure is being recalled
- You should contact your Dealer or Aero Industries to receive the repair kit required to address this recall
- Conestoga systems affected that you have purchased are identified in Attachment A

Why is a recall being conducted?

The defect involves rivets loosening or pulling out on the rear RAD closure. This defect could result in the RAD falling off the rear bow assembly causing a road hazard increasing the risk of a crash. The intermediate issue may be an insecure clamping of the rear curtain.

What may cause the defect?

Rivets may become loose if blunt object forcibly hits the RAD.

Rivets may become loose if trailer is backed into a dock with RAD closure in the open position.

Rivets may fatigue over time due to improper use of the RAD as a handle to move the system. Handle on the rear bow should be used for this purpose.

What are we doing about the problem?

A repair kit has been created to provide a secure connection. The repair will consist of adding a bolt, nut and washer to the top and bottom of each side of the RAD curtain closure. **The repair kit includes instructions, nuts and bolts as well as the proper drill bit and Allen wrench to make this repair.** The repair kit will be provided at no cost to you. No parts need to be returned to Aero. Dealers/owners may begin receiving parts and instructions beginning in August 2016.

We estimate this repair to take approximately 1 hour

What should you do?

You should immediately contact your Dealer or Aero Industries to get your repair kit.

As a regular part of your equipment inspections, include rear curtain closure componentry to ensure there is no immediate danger of the RAD coming loose.

What if you no longer own this Conestoga XP system?

If you no longer own the Conestoga system affected by this recall, please contact your local Dealer or Aero industries at 1-800-535-7563 to provide new owner contact information.

Who should you contact if you have further questions or concerns?

You should contact Aero Industries at 800-535-7563

If you are the lessor of this vehicle, please forward a copy of this notice to the lessee within ten days to comply with Federal regulations.

If you have already paid to have your Conestoga XP system repaired for this condition, you may be eligible for reimbursement of the charges. To learn more about what you need to do to obtain reimbursement please call Aero Industries at (800) 535-7563

If after having attempted to take advantage of this recall you believe you have not been able to have your Conestoga XP system remedied without charge and within a reasonable amount of time, you may submit a complaint to the Administrator, National Highway Traffic Safety Administration, 1200 New Jersey Ave., Washington, D.C., 20590; or call the toll-free Vehicle Safety Hotline at 1-888-327-4236 (TTY: 1-800-424-9153); or go to <http://www.safercar.gov>

We apologize for any inconvenience this safety recall may cause, but your safety is our first concern.

Sincerely,

Aero Industries



Rivet Replacement

Kits:

0201-968576 – HARDWARE PACK, REPAIR AERO RAD CLAMPS, 8 BOLTS

(8ea) ¼"-20 Nylock Jam Nut

(8ea) ¼"-20 x ½" Button Head Socket Cap Screw

0201-968575 – HARDWARE PACK, REPAIR CXP FRONT WINGS, 8 BOLTS

(8ea) ¼"-20 Cap Nut

(8ea) ¼"-20 x 1.75" Button Head Socket Cap Screw

0201-968577 – TOOL KIT, WING REPAIR 5/32" ALLEN, G & 3/8" BITS

(2ea) 5/32" Steel Allen Key

(1ea) 3/8" Drill Bit

(1ea) "G" Drill Bit



Tarp System Innovation Since 1944

Rear Curtain Lock

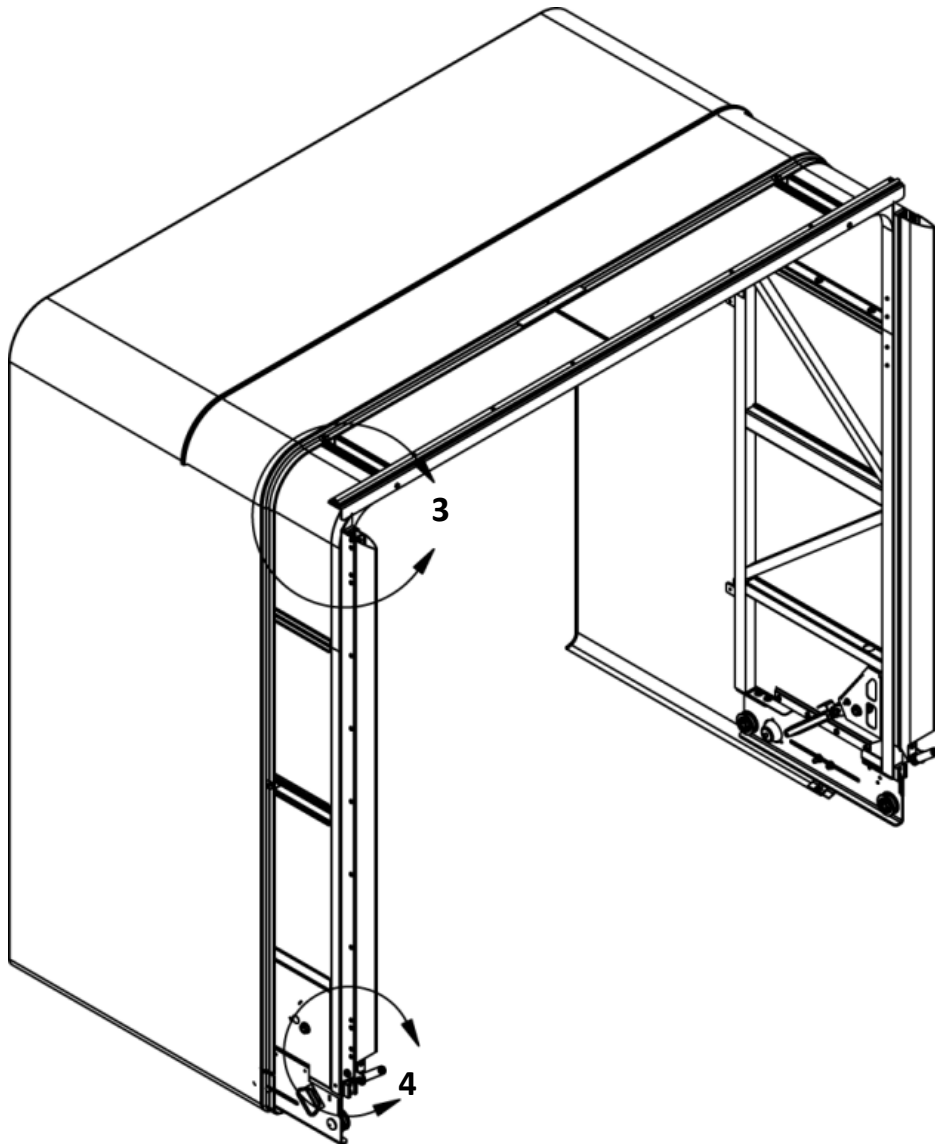

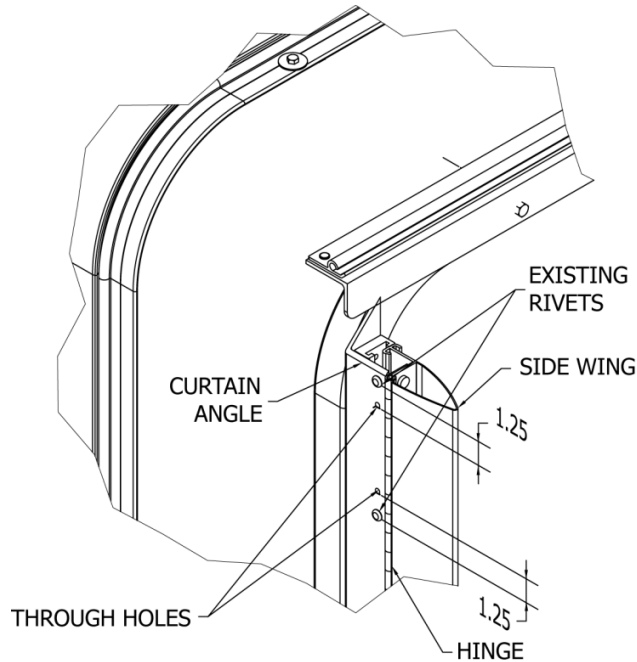

Detail 3

Locate the top two rivets on the angle side of the hinge. Using the included "G" drill bit, drill holes 1.25" below the top rivet and 1.25" above the bottom rivet. Holes are to go through the hinge and the angle. (Do not drill through the side wing.) All rear lock details show the driver side. The passenger side is to be done the same.

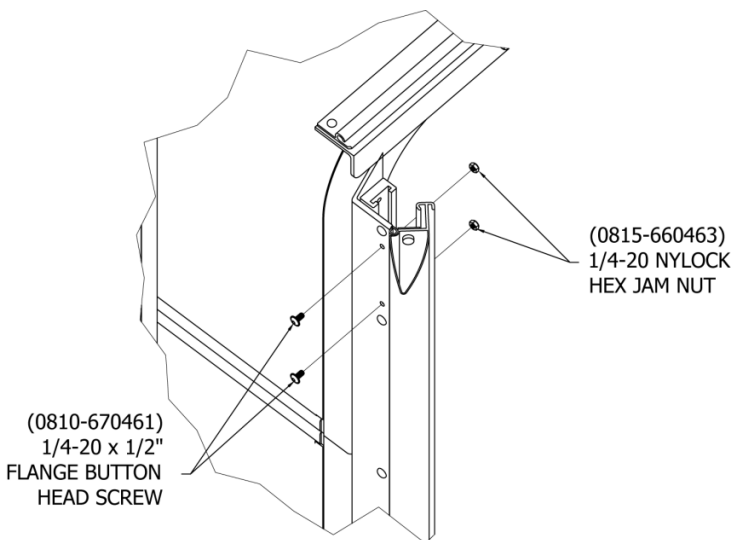

Detail 3A

Locate (2ea) 1/4"-20 x 1/2" Flange Button Head Screws and (2ea) 1/4"-20 Nylock Hex Jam Nuts in the hardware pack. Insert the screws as shown. Open side wing to gain access to screw threads. Attach Jam Nuts. Tighten using the (1)

included 5/32" Allen Wrench and (1) 7/16" Wrench.

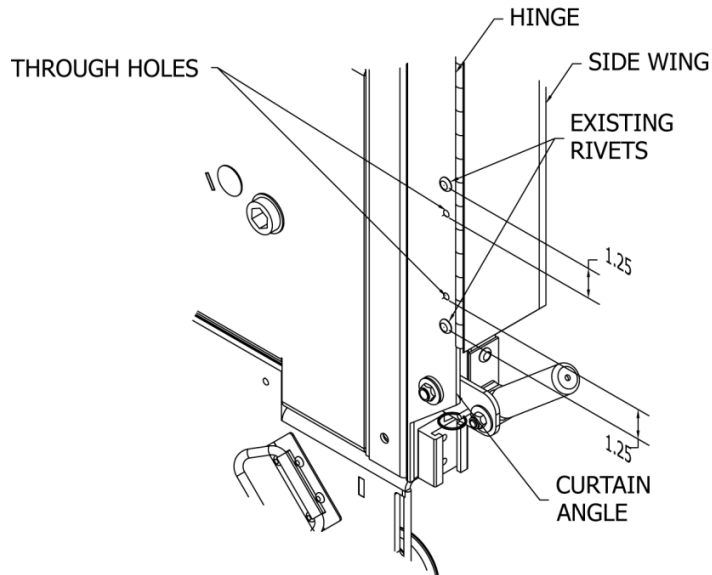

Detail 4

Locate the bottom two rivets on the angle side of the hinge. Using the included "G" drill bit, drill holes 1.25" below the top rivet and 1.25" above the bottom rivet. Holes are to go through the hinge and the angle. (Do not drill through the side wing.)

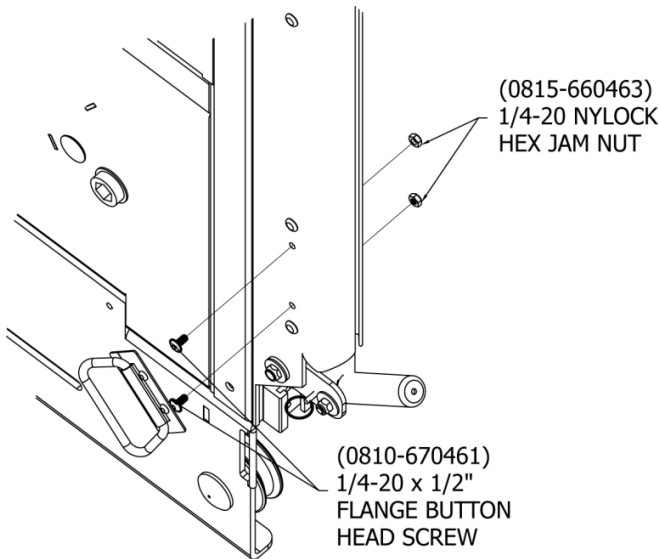

Detail 4a

Locate (2ea) 1/4"-20 x 1/2" Flange Button Head Screws and (2ea) 1/4"-20 Nylock Hex Jam Nuts in the hardware pack. Insert the screws as shown. Open side wing to gain access to screw threads. Attach Jam Nuts. Tighten using the (1) included 5/32" Allen Wrench and (1) 7/16" Wrench.



Front Lock

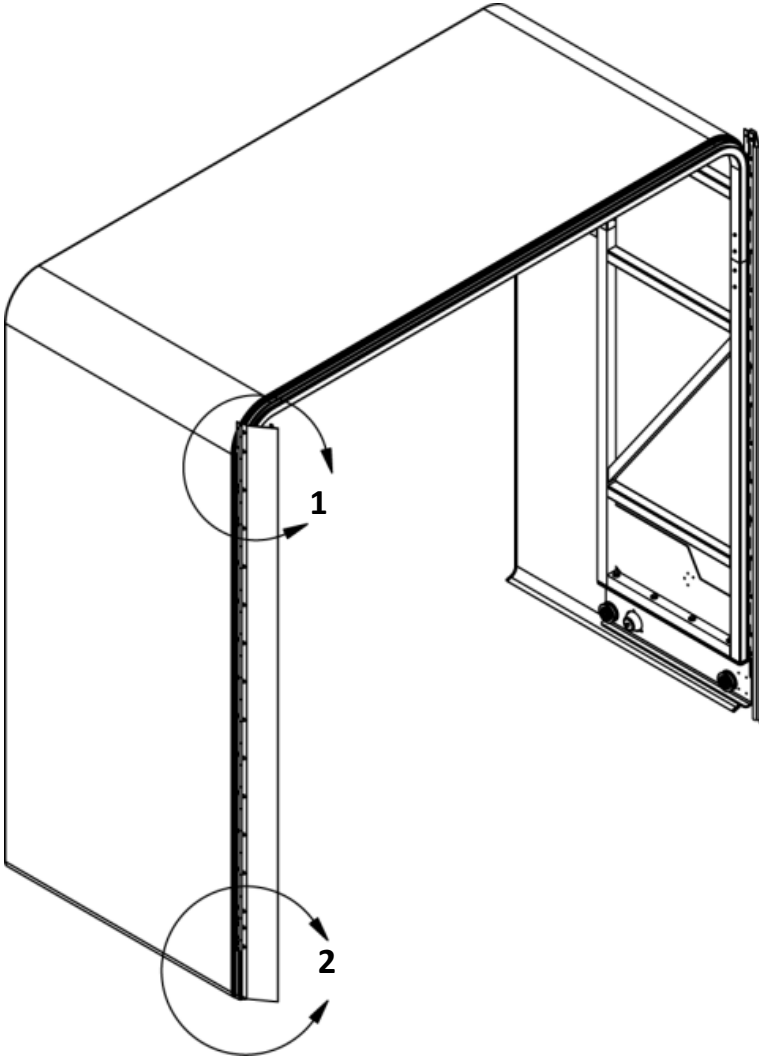



Detail 1

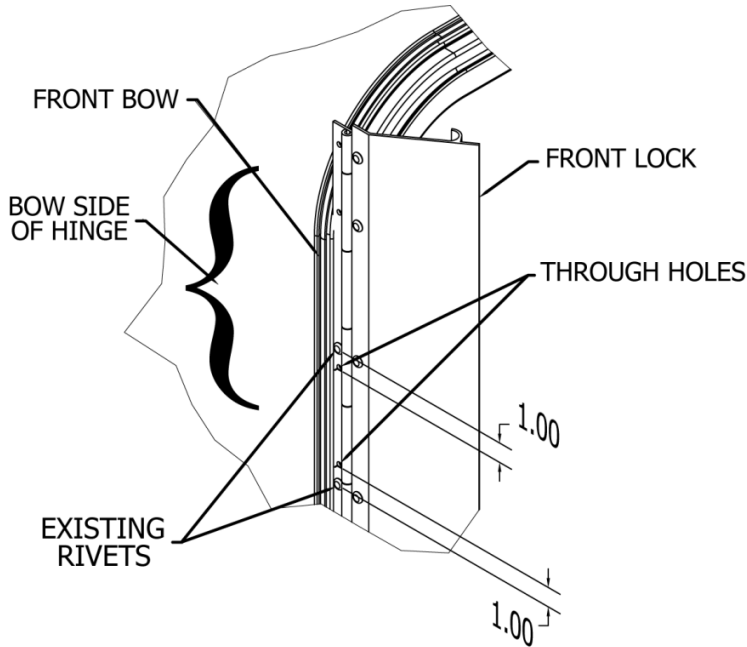

Locate the top two rivets on the bow side of the hinge. Using the included "G" drill bit, drill holes 1" below the top rivet and 1" above the bottom rivet. Holes are to go all the way through the hinge and both walls of the bow. All front lock details show the passenger side. The driver side is to be done the same.

Detail 1A

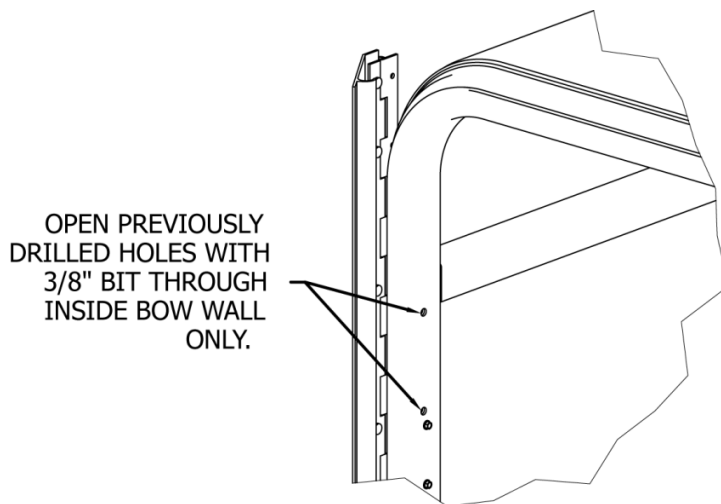

Using the included 3/8" drill bit, enlarge the two holes from the previous step. Drill through the inside wall only.

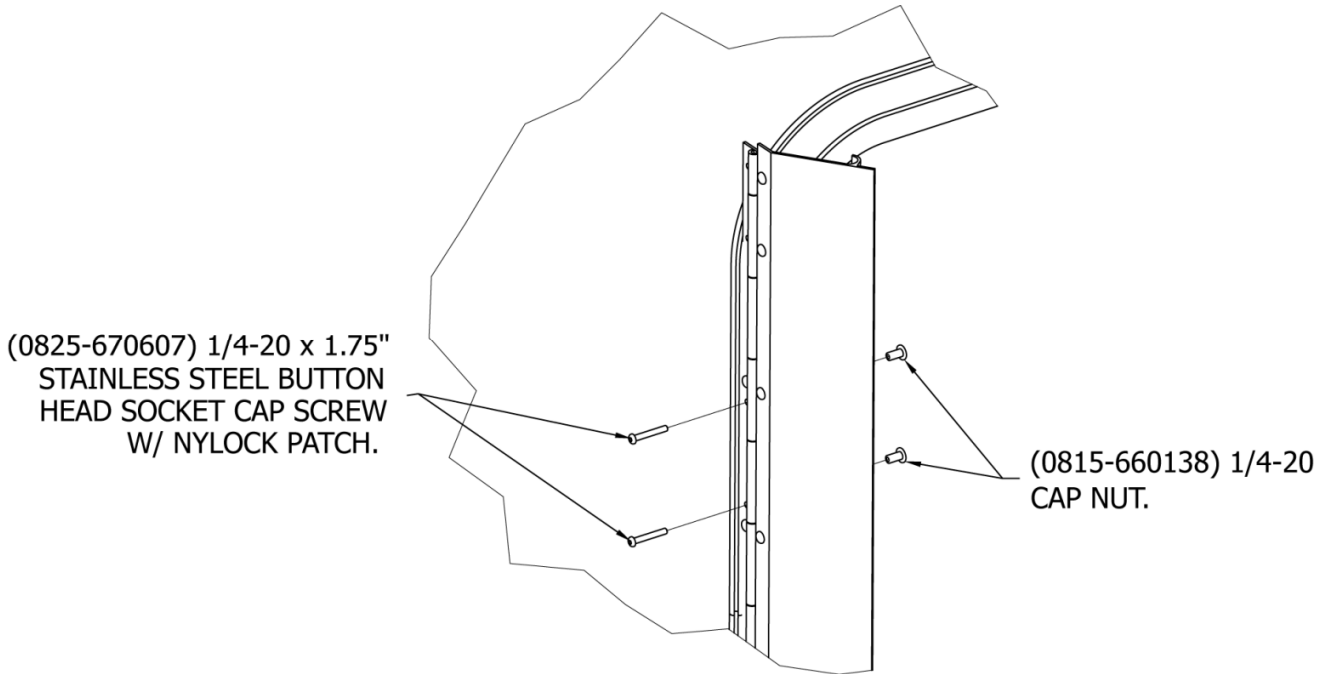

Detail 1B

Locate (2ea) 1/4"-20 x 1.75" Stainless Steel Button Head Socket Cap Screws and (2ea) 1/4"-20 Cap nuts in the hardware pack. Insert the cap nuts in the 3/8" holes on the inside wall of the front bow. Insert the button head screws through the bow and into the cap nuts. Tighten using the (2) included 5/32" Allen Wrenches.

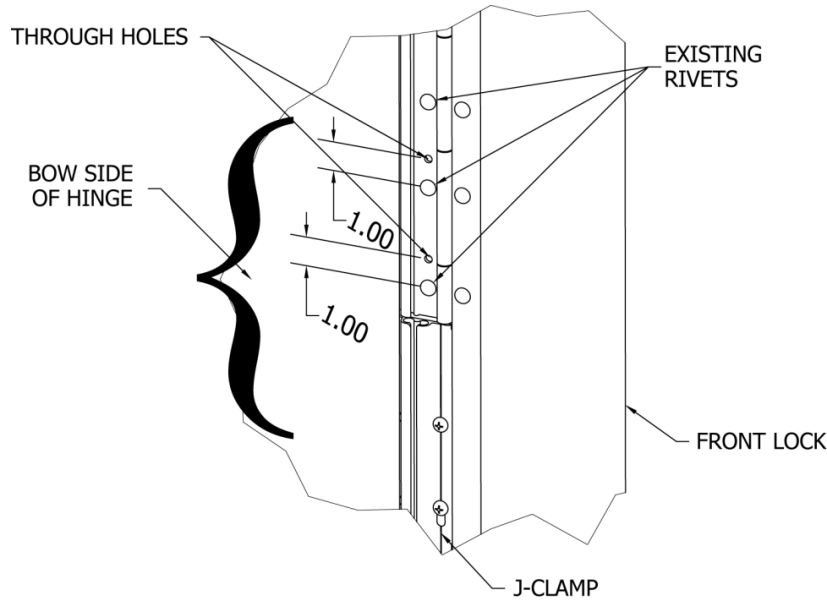

Detail 2

Locate the bottom two rivets on the bow side of the hinge, just above the J-Clamp.

Using the included "G" drill bit, drill holes 1" above each of the two rivets. Holes are to go all the way through the

hinge and both walls of the bow.

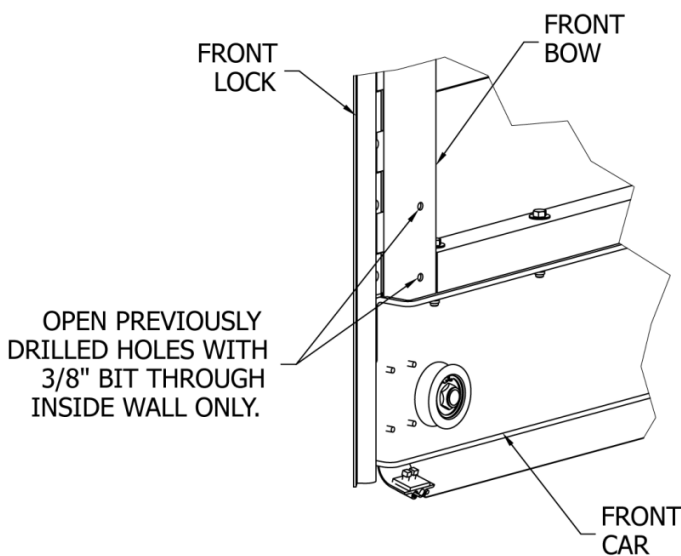

Detail 2A

Using the included 3/8" drill bit, enlarge the two holes from the previous step. Drill through the inside wall only.



Tarp System Innovation Since 1944

(0825-670607) 1/4-20 x 1.75"
BUTTON HEAD SOCKET
CAP SCREW W/ NYLOCK PATCH.

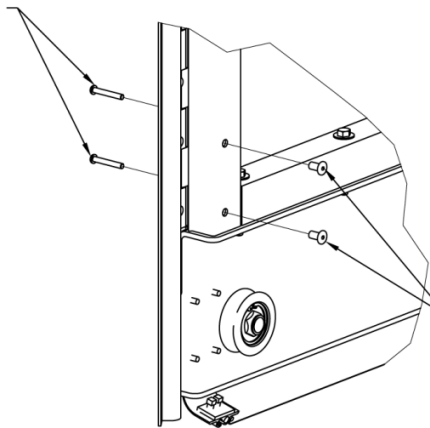

(0815-660138) 1/4-20
CAP NUT

Detail 2B

Locate (2ea) 1/4"-20 x 1.75" Stainless Steel Button Head Socket Cap Screws and (2ea) 1/4"-20 Cap nuts in the hardware pack. Insert the cap nuts in the 3/8" holes on the inside wall of the front bow. Insert the button head screws through the bow and into the cap nuts. Tighten using the (2) included 5/32" Allen Wrenches.



Tarp System Innovation Since 1944