



AUTOMOBILE DIVISION

American Honda Motor Co., Inc.
1919 Torrance Blvd., - P.O. Box 2215
Torrance, CA 90509-9870

March 2017

NHTSA Recall 16V-344

IMPORTANT SAFETY RECALL

This notice applies to your vehicle: 999999999999999999

Dear JOHN Q SAMPLE:

This notice is sent to you in accordance with the National Traffic and Motor Vehicle Safety Act.

WHAT IS THE REASON FOR THIS NOTICE?

Honda has decided that a defect which relates to motor vehicle safety exists in certain 2003-2011 model year Element vehicles. The propellant wafers in some of the subject inflators may degrade over time, which could lead to over-aggressive combustion in the event the airbag is activated. Overly aggressive combustion creates excessive internal pressure when the inflator is activated, which may cause the inflator body to rupture. In the event of an inflator rupture, metal fragments could pass through the airbag cushion material possibly causing injury to vehicle occupants.

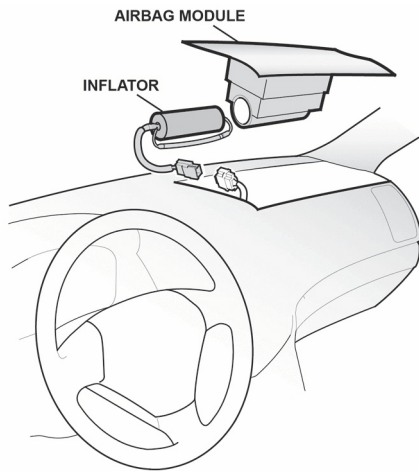

WHAT WILL HONDA DO?

Honda will replace the passenger frontal airbag inflator free of charge. An illustration showing the location of the passenger frontal airbag inflator, which is the only component of the airbag module (other components are the airbag cushion and airbag module cover) that will be replaced, during the recall repair, is shown on the left.

While parts are available to conduct airbag inflator replacements at the time of this notice, the scope of the current airbag inflator recalls creates the possibility that the parts necessary to complete the recall repair may not be available at the time you call to schedule your appointment with your authorized Honda dealer.

WHAT SHOULD YOU DO?

Call any authorized dealer and make an appointment to have this recall fixed. The complete inspection and repair time may take approximately 48-54 minutes however, please confirm with your dealer the amount of time your vehicle will need to be at the dealership. If you are not the only driver of this vehicle, please advise all other drivers and passengers of this important information!

Honda suggests that you avoid having a passenger sit in the front passenger's seat until the recall repair has been performed.

CHECK YOUR VEHICLE FOR OPEN RECALLS

To check your vehicle's eligibility for repair under this or any other recall, please visit the *Honda Recall Lookup* tool at www.recalls.honda.com and enter your Vehicle Identification Number (VIN).

OWNER INFORMATION

You received this notice because government regulations require that notification be sent to the last known owner of record. Our records are based primarily on state registration and title data, which indicate that you are the current owner of this vehicle. If this is not the case, or if any of the information is not correct, please complete, sign and return the Information Change Card and we will then update our records. If you are a lessor of this vehicle, federal regulations require you to forward this notice to your lessee within ten days.

DO YOU STILL HAVE MORE QUESTIONS?

Should you have any questions about this recall, please contact your authorized Honda dealer. Should you need additional assistance, you may contact Honda Automobile Customer Service at 1-888-234-2138.

If you believe that American Honda or the dealer has failed or is unable to remedy the defect in your vehicle, without charge, within a reasonable period of time (60 days from the date you first contact the dealer for a repair appointment), you may submit a complaint to the Administrator, National Highway Traffic Safety Administration, 1200 New Jersey Ave., SE, Washington, DC 20590. Alternatively, you may call the NHTSA's toll-free Safety Hotline at 888-327-4236 (TTY 800-424-9153), or go to <http://www.safercar.gov>.

We apologize for any inconvenience this recall may cause you.

Sincerely,

**American Honda Motor Co., Inc.
Honda Automobile Division**

Campaign #KA0 / Service Bulletin #16-047

0315-02-00-0000004-0002-0000009