



Michael A. Berardi
Director
Service Engineering Operations
Ford Customer Service Division

Ford Motor Company
P. O. Box 1904
Dearborn, Michigan 48121

December 1, 2016

TO: All U.S. Ford and Lincoln Dealers

SUBJECT: **NEW VEHICLE DEMONSTRATION / DELIVERY HOLD - Safety Recall 16S43**
Certain 2017 Model Year Fusion Vehicles
Rear 60% Seat Backrest Frame Replacement

AFFECTED VEHICLES

Vehicle	Model Year	Assembly Plant	Build Dates
Fusion	2017	Hermosillo	September 27, 2016 through September 28, 2016

Affected vehicles are identified in OASIS and FSA VIN Lists.

REASON FOR THIS SAFETY RECALL

In some of the affected vehicles, the rear 60% seat backrest frame may have insufficient welds. Seat backrest frames that were improperly welded may not retain cargo in a crash, increasing the risk of injury.

SERVICE ACTION

Before demonstrating or delivering any new in-stock vehicles involved in this recall, dealers are to replace the rear 60% seat backrest frame. This service must be performed on all affected vehicles at no charge to the vehicle owner.

OWNER NOTIFICATION MAILING SCHEDULE

Owner letters are expected to be mailed the week of January 9, 2017. Dealers should repair any affected vehicles that arrive at their dealerships, whether or not the customer has received a letter.

PLEASE NOTE:

Federal law requires dealers to complete this recall service before a new vehicle is delivered to the buyer or lessee. Violation of this requirement by a dealer could result in a civil penalty of up to \$21,000 per vehicle. Correct all vehicles in your new vehicle inventory before delivery.

ATTACHMENTS

Attachment I: Administrative Information
Attachment II: Labor Allowances and Parts Ordering Information
Attachment III: Technical Information
Owner Notification

QUESTIONS & ASSISTANCE

For questions and assistance, contact the Special Service Support Center (SSSC) via the SSSC Web Contact Site. The SSSC Web Contact Site can be accessed through the Professional Technician Society (PTS) website using the SSSC link listed at the bottom of the OASIS VIN report screen or listed under the SSSC tab.

Sincerely,

A handwritten signature in black ink, appearing to read "Michael A. Berardi". The signature is fluid and cursive, with a prominent initial "M".

Michael A. Berardi

NEW VEHICLE DEMONSTRATION / DELIVERY HOLD - Safety Recall 16S43

Certain 2017 Model Year Fusion Vehicles
Rear 60% Seat Backrest Frame Replacement

OASIS ACTIVATION

OASIS will be activated on December 1, 2016.

FSA VIN LISTS ACTIVATION

FSA VIN Lists will be available through <https://web.fsavinlists.dealerconnection.com> on December 1, 2016. Owner names and addresses will be available by January 20, 2017.

NOTE: Your FSA VIN Lists may contain owner names and addresses obtained from motor vehicle registration records. The use of such motor vehicle registration data for any purpose other than in connection with this recall is a violation of law in several states, provinces, and countries.

Accordingly, you must limit the use of this listing to the follow-up necessary to complete this recall.

SOLD VEHICLES

- Owners of affected vehicles will be directed to dealers for repairs.
- Immediately contact any of your affected customers whose vehicles are not on your VIN list but are identified in OASIS. Give the customer a copy of the Owner Notification Letter (when available) and schedule a service date.
- Correct other affected vehicles identified in OASIS which are brought to your dealership.
- Dealers are to prioritize repairs of customer vehicles over repairs of new and used vehicle inventory.

STOCK VEHICLES

- Correct all affected units in your new vehicle inventory before delivery.
- Use OASIS to identify any affected vehicles in your used vehicle inventory.

DEALER-OPERATED RENTAL VEHICLES

A new law prohibits a Rental Company from selling, renting or leasing vehicles subject to a safety or compliance recall. This could impact dealer-operated rental fleets of 35 vehicles or more, including FRAC, LRAC, and DDR vehicles. Please see EFC04833 for details and consult your legal counsel for legal advice.

TITLE BRANDED / SALVAGED VEHICLES

Affected title branded and salvaged vehicles are eligible for this recall.

ADDITIONAL REPAIR (LABOR TIME AND/OR PARTS)

Additional repairs identified as necessary to complete the FSA should be managed as follows:

- For vehicles within new vehicle bumper-to-bumper warranty coverage, follow existing warranty and policy guidelines for related damage claims. No SSSC approval is required for these vehicles:
 - Ford vehicles – 3 years or 36,000 miles
- For vehicles outside new vehicle bumper-to-bumper warranty coverage, submit an Approval Request to the SSSC Web Contact Site prior to completing the repair.

NEW VEHICLE DEMONSTRATION / DELIVERY HOLD - Safety Recall 16S43

Certain 2017 Model Year Fusion Vehicles
Rear 60% Seat Backrest Frame Replacement

OWNER REFUNDS

Refunds are not approved for this program.

RENTAL VEHICLES

The use of rental vehicles is not approved for this program.

CLAIMS PREPARATION AND SUBMISSION

- Enter claims using Direct Warranty Entry (DWE) or One Warranty Solution (OWS).
 - DWE: refer to ACESII manual for claims preparation and submission information.
 - OWS: when entering claims in DMS software, select claim type 31: Field Service Action. The FSA number 16S43 is the sub code.
- Additional labor and/or parts must be claimed as related damage on a separate repair line from the FSA.

NEW VEHICLE DEMONSTRATION / DELIVERY HOLD - Safety Recall 16S43

Certain 2017 Model Year Fusion Vehicles
Rear 60% Seat Backrest Frame Replacement

LABOR ALLOWANCES

Description	Labor Operation	Labor Time
Replace Rear 60% Seat Backrest Frame	16S34B	1.0 Hours

PARTS REQUIREMENTS / ORDERING INFORMATION

Part Number	Description	Order Quantity
EU5Z-96613A39-B	Rear 60% Seat Backrest Frame	1

The DOR/COR number for this recall is 51066.

Order your parts through normal order processing channels. To guarantee the shortest delivery time, an emergency order for parts must be placed.

DEALER PRICE

For latest prices, refer to DOES II.

PARTS RETENTION AND RETURN

Follow the provisions of the Warranty and Policy Manual, Section 1 - WARRANTY PARTS RETENTION AND RETURN POLICIES.

EXCESS STOCK RETURN

Excess stock returned for credit must have been purchased from Ford Customer Service Division in accordance with Policy Procedure Bulletin 4000.

CERTAIN 2017 MODEL YEAR FUSION VEHICLES — REAR 60% SEAT BACKREST FRAME REPLACEMENT

OVERVIEW

In some of the affected vehicles, the rear 60% seat backrest frame may have insufficient welds. Seat backrest frames that were improperly welded may not retain cargo in a crash, increasing the risk of injury. Before demonstrating or delivering any new in-stock vehicles involved in this recall, dealers are to replace the rear 60% seat backrest frame. This service must be performed on all affected vehicles at no charge to the vehicle owner.

SERVICE PROCEDURE

1. Remove the rear seat 60% backrest. Please follow the Workshop Manual (WSM) procedures in Section 501-10B.
2. Remove the armrest. Please follow the WSM procedures in Section 501-10B.
3. Remove the rear center seatbelt guide bezel. See Figure 1.

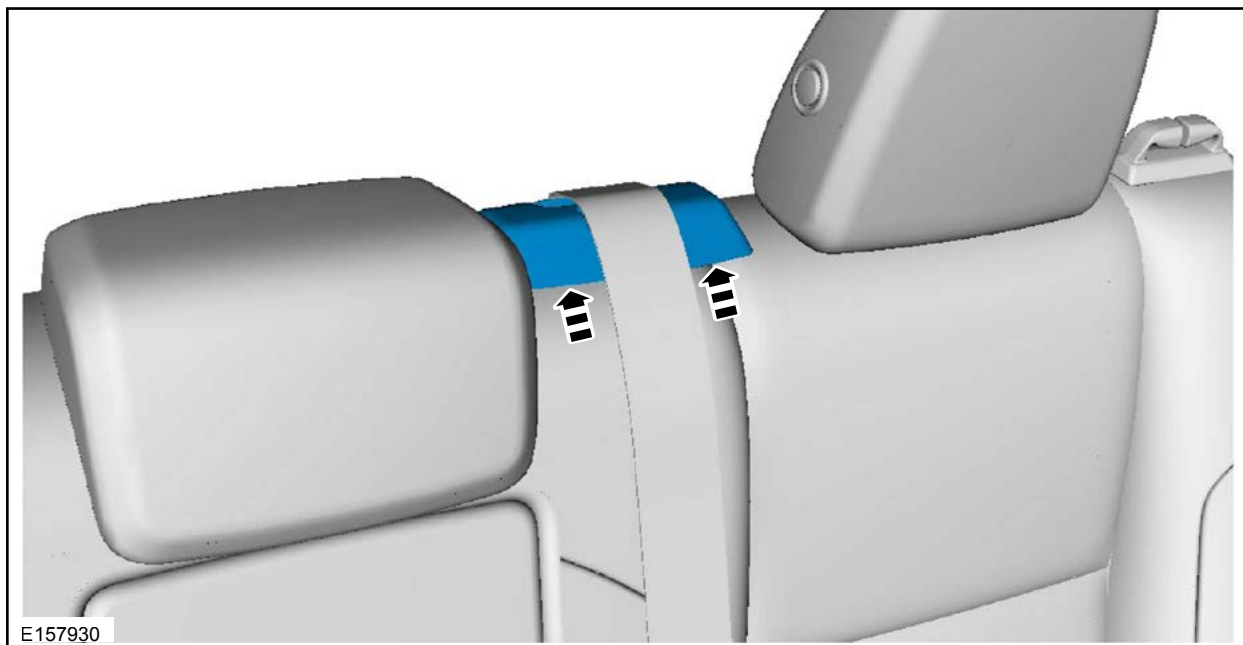

FIGURE 1

4. Remove the rear head restraint guide sleeves. Please follow the WSM procedures in Section 501-10B.



5. Release the clips and remove the latch and release handle bezels. See Figure 2.

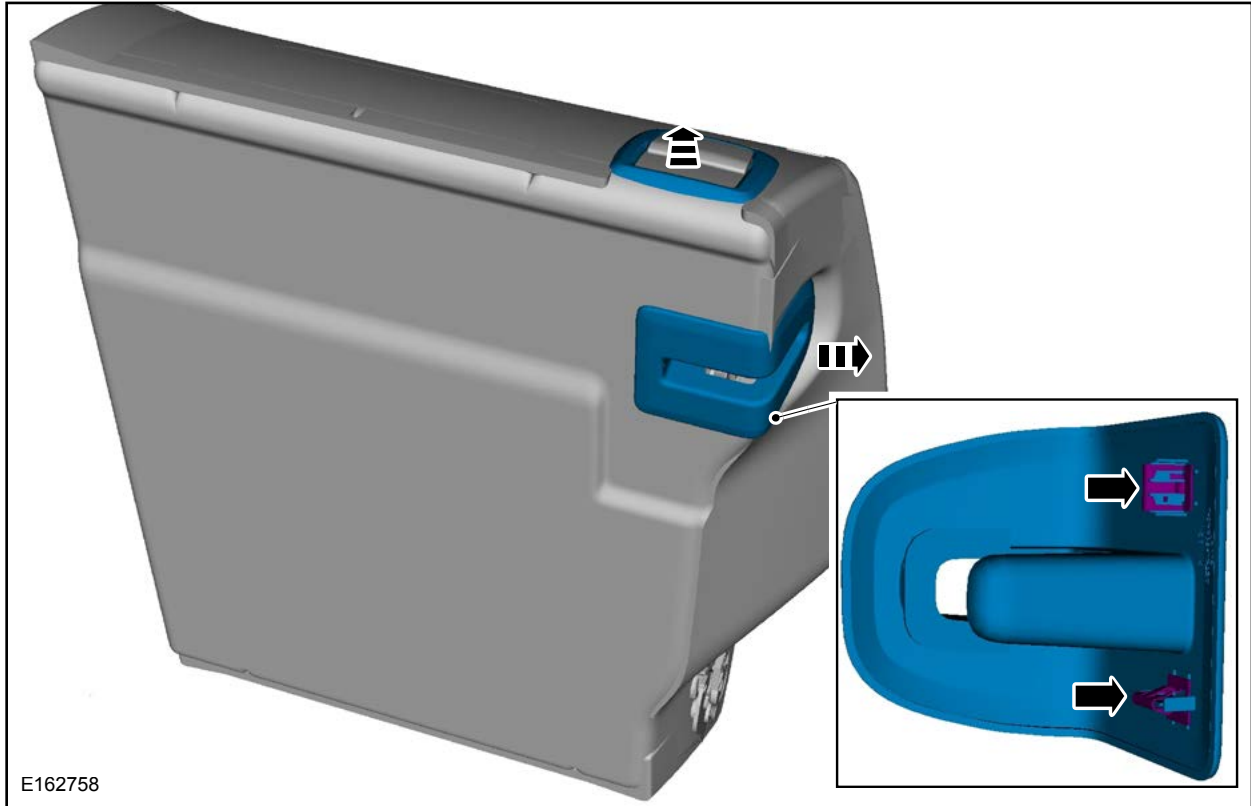

FIGURE 2



6. Detach J-clips from the frame. See Figures 3 and 4.

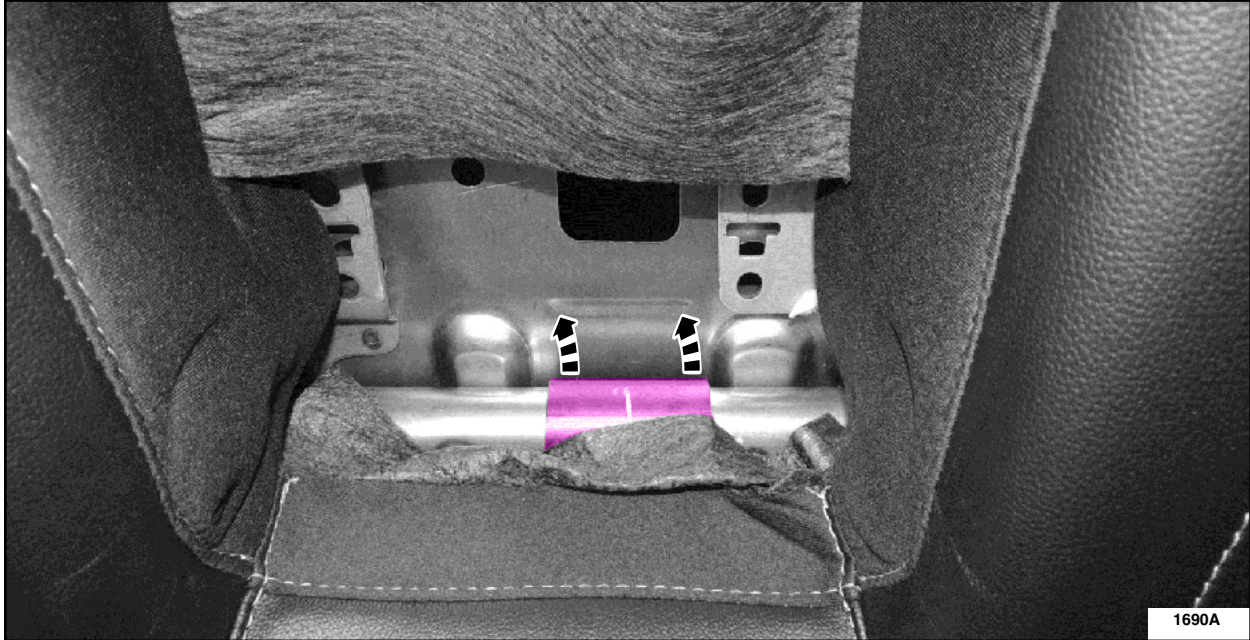

FIGURE 3

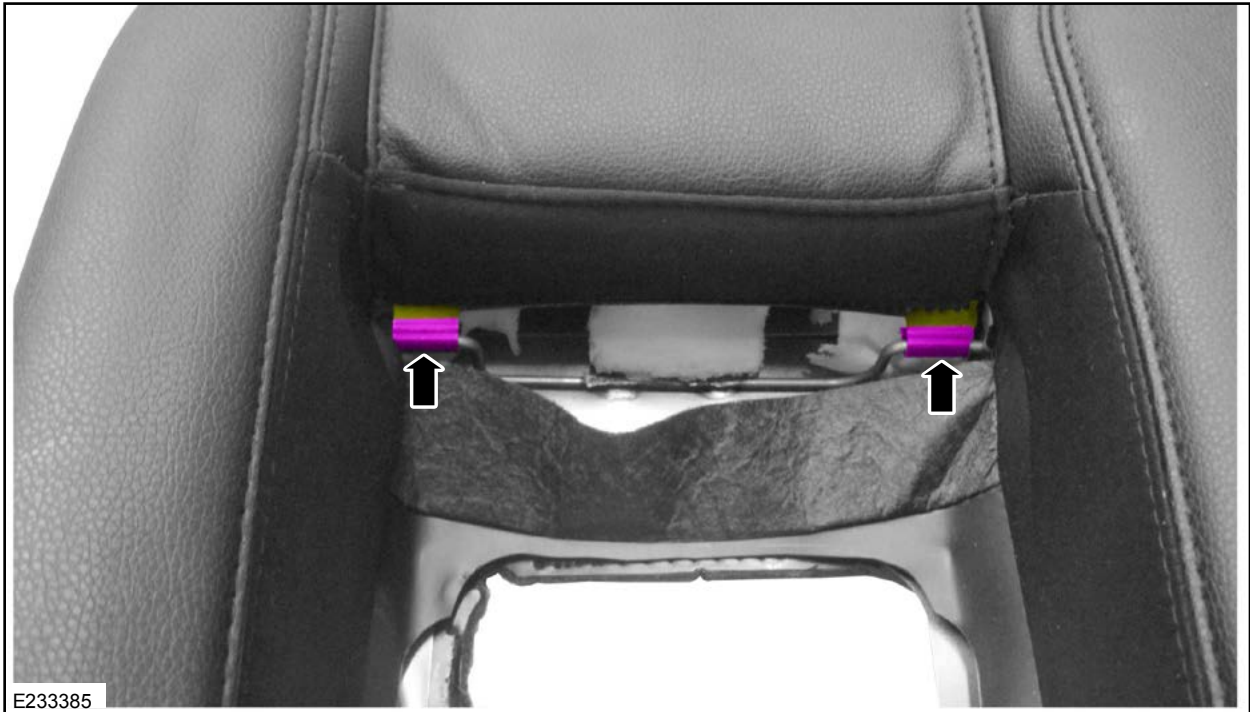

FIGURE 4



7. Remove and discard the LH safety belt anchor bolt retainer. See Figure 5.

- It is not necessary to replace the anchor bolt retainer.

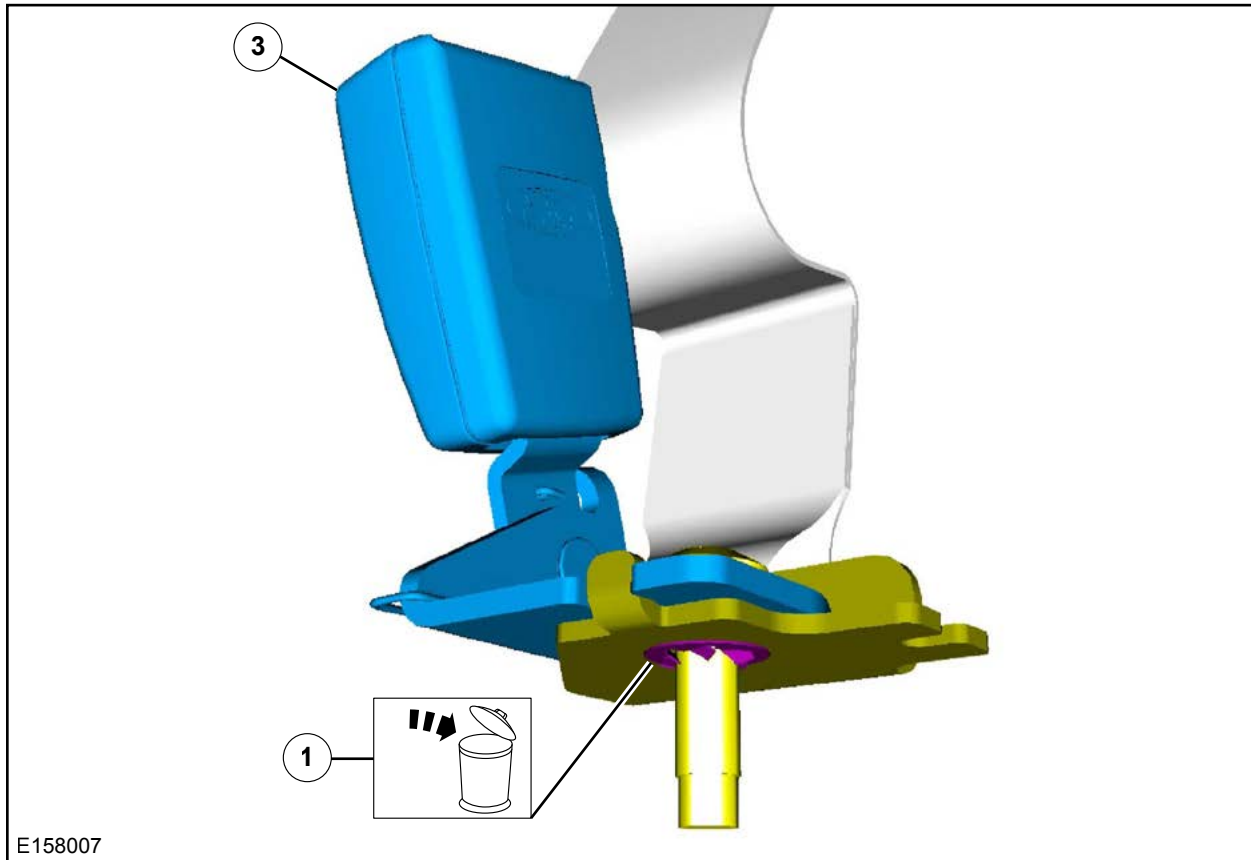

FIGURE 5

8. Route the seatbelt through the guide. See Figure 6.

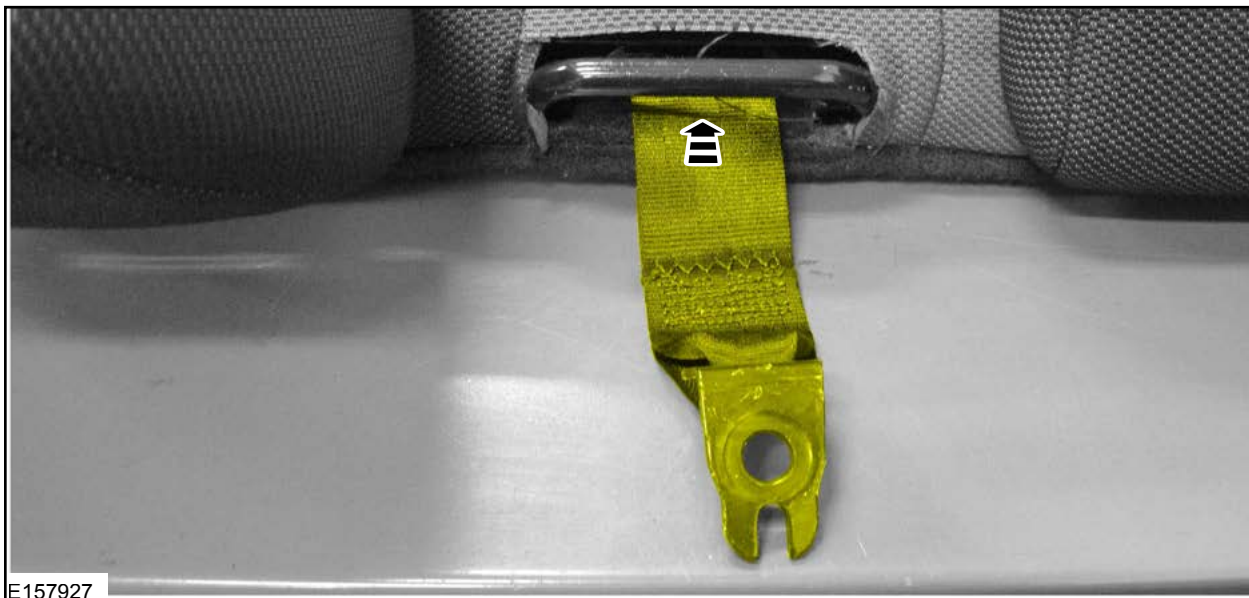

FIGURE 6



9. Pull the seat cover over the rear seat guide pin and position aside. See Figure 7.



FIGURE 7

10. Pull the seat cover over the top of the frame. See Figure 8.

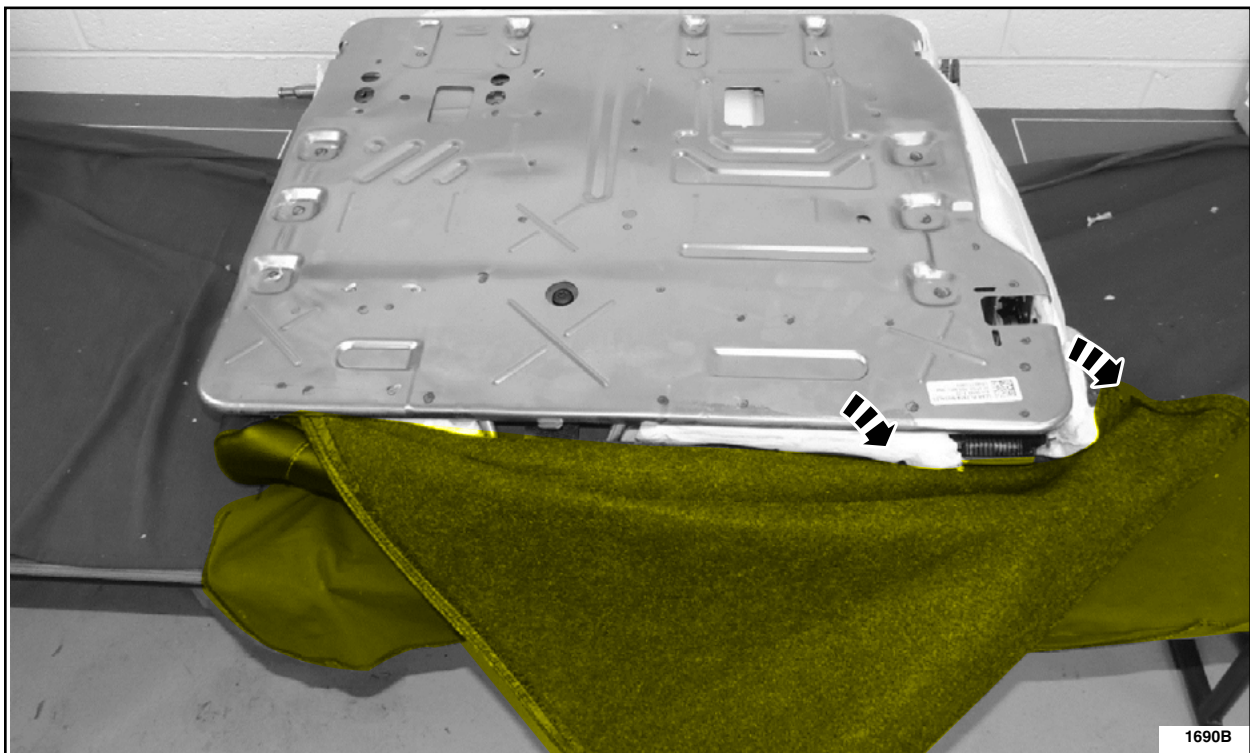

FIGURE 8



11. Lift the frame upward and detach the wire harness retainer, if equipped. See Figure 9.

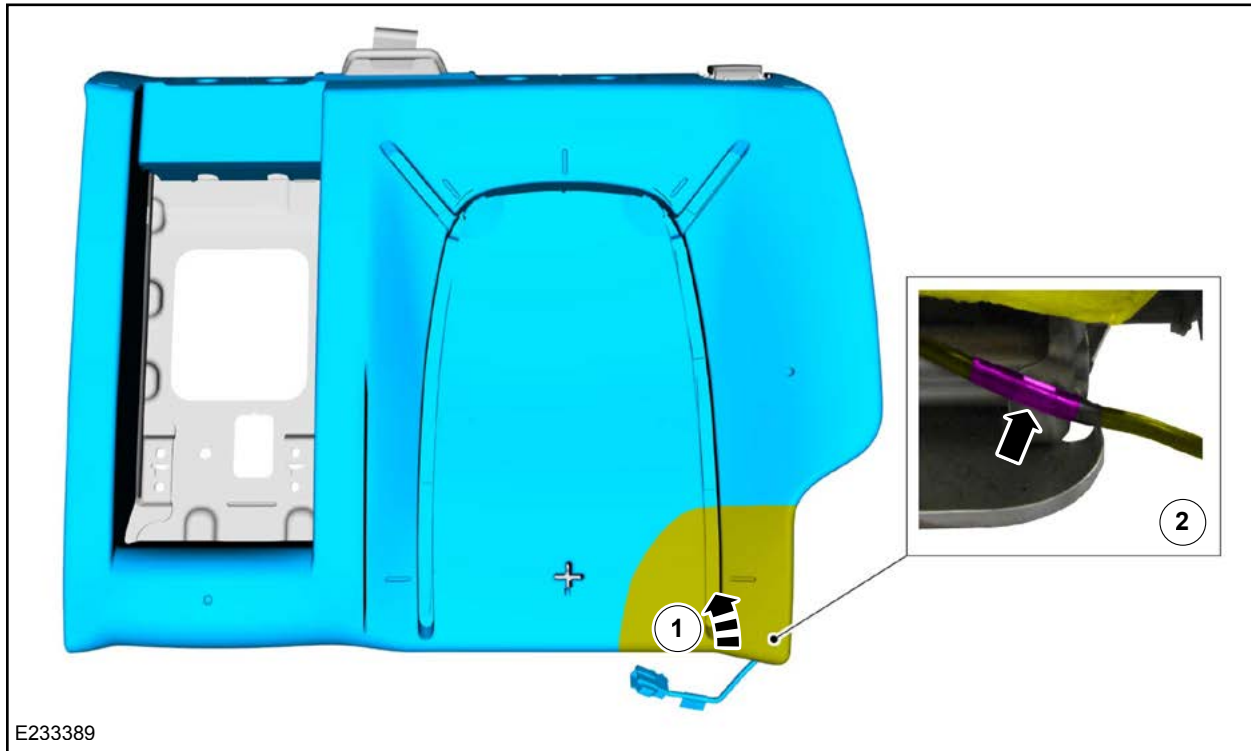

FIGURE 9

12. Lift the frame upward and remove it from the cushion. See Figure 10.

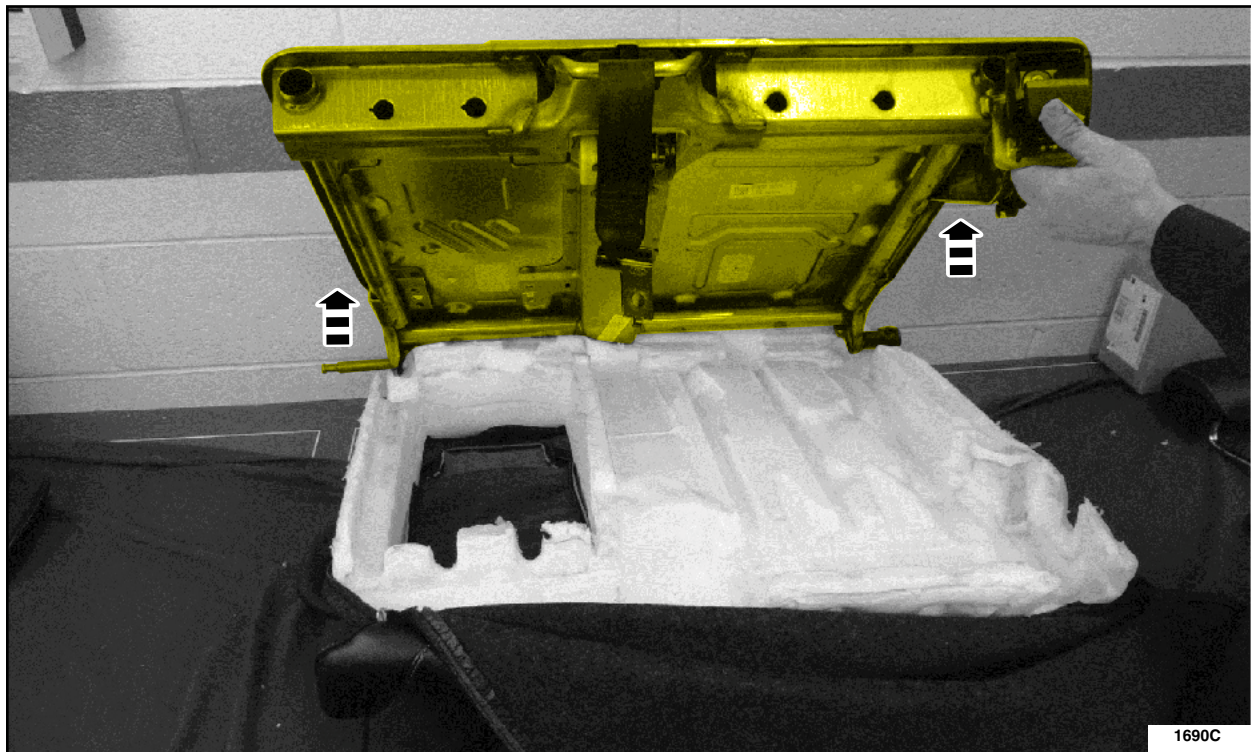

FIGURE 10



13. Remove the screw, detach the lever and remove the latch handle. See Figure 11.

- Torque: 44 lb.in (5 Nm)

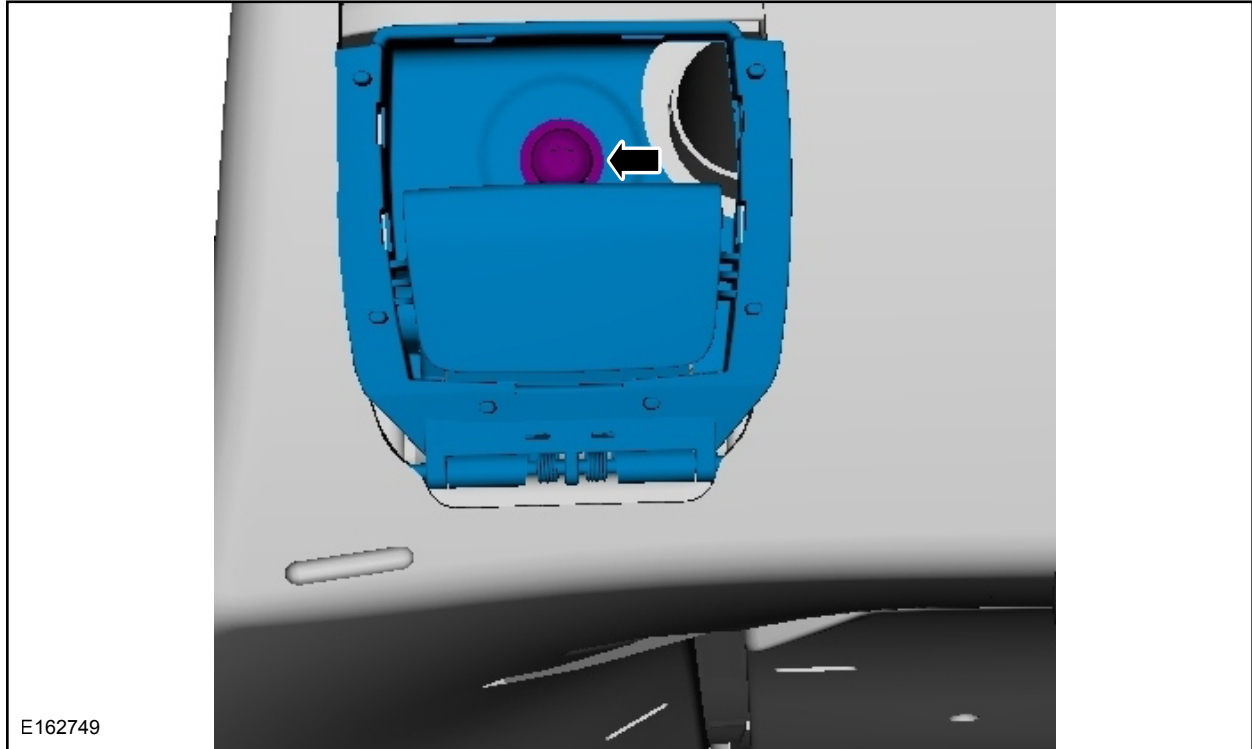

FIGURE 11



NOTE: Prior to removal, note the location of the seat locking cam for installation.

14. Transfer the following components to the *new* frame: (See Figure 12.)

1. Center seatbelt retractor.
 - Torque: 30 lb.ft (40 Nm)
2. Seat latch.
 - Torque: 18 lb.ft (24 Nm)
3. Seat locking cam.
 - Torque: 35 lb.ft (48 Nm)

NOTE: During assembly, ensure that the seatbelt is properly routed through the guide.
See Figures 6 and 12.

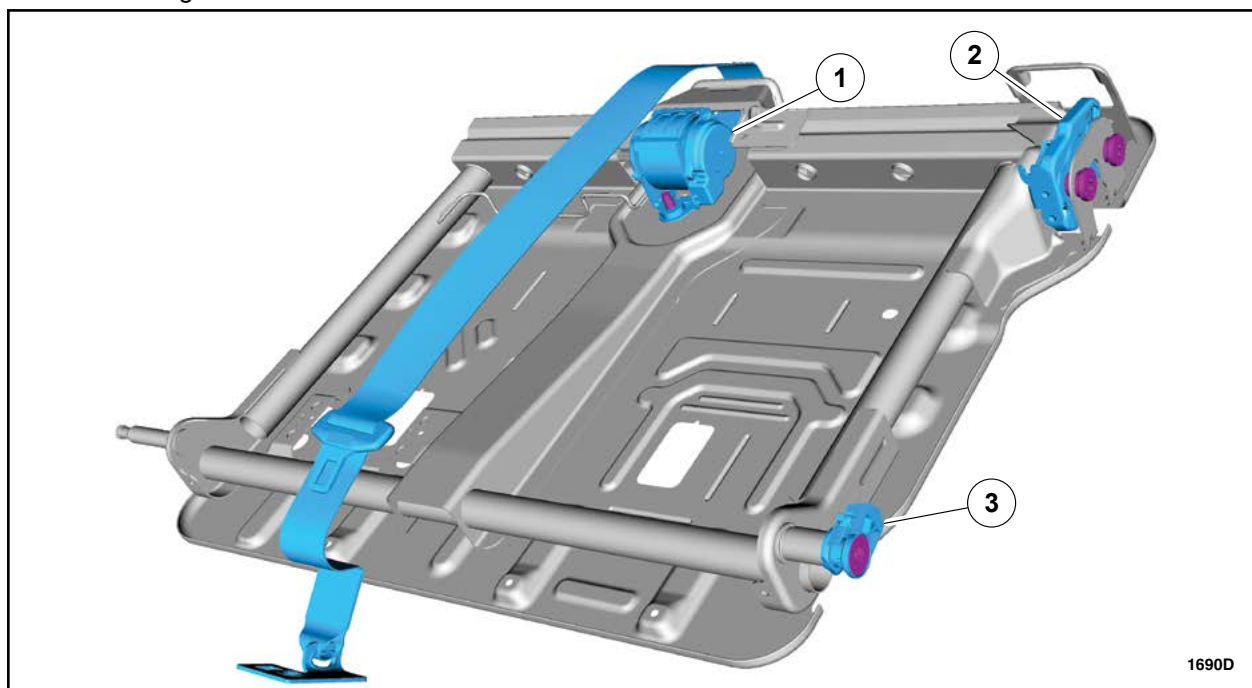

FIGURE 12

15. Install the seat cushion and cover onto the *new* frame by reversing the removal procedure.

16. Check the LH rear safety belt and buckle for correct operation. For additional information refer to WSM Section 501-20.

