

IMPORTANT SAFETY RECALL



DEPARTMENT OF COMPLIANCE
VEHICLE SAFETY AND RECALL MANAGEMENT
BUILDING 11
423 N MAIN ST
MIDDLEBURY, INDIANA 46540-9218

NHTSA RECALL: 16V682
CANADA RECALL: 2016-459

- o Integrity
- o Safety
- o Quality
- o Customer Service

<<DEALERNAME>>
<<ADDRESS>>
<<CITY>>, <<ST>> <<ZIP-XXX>>

October 24, 2016

Pursuant to USC49CFR §577.13 – Notification to Dealerships and Distributors – Paragraph B

“It is a violation of Federal Law for a dealer to deliver a new motor vehicle or any new or used item of motor vehicle equipment (including a tire) covered by the notification under a sale or lease until the defect or noncompliance is remedied. Substantial civil penalties apply to violations of this law.”

–Forest River motorized and towable products are contained in this section–

CANADA: Pursuant to the Canadian Motor Vehicle Safety Act, section 5

Companies who sell new non-complying vehicles may be in violation of the Motor Vehicle Safety Act. Substantial penalties apply to violations of this law.

Forest River – Office of Corporate Compliance (“OCC”) has decided that a safety defect exists in certain 2016 and 2017 model year Amera-Lite - ALDD610SA, ALDR610SA, ALDD612SA and ALDR612SA. Forest River is recalling the defect model(s) to ensure the safety of our future retail consumers and your dealership. Forest River apologizes for any inconvenience this action may cause your dealership; however, safety continued satisfaction and our commitment to building great products are of the utmost importance to Forest River.

The identified VIN referenced in the attached document(s).

The designated Date range of production is February, 2016 through May, 2016.

DEFECT/NONCOMPLIANCE:

The drawbars and coupler welded to the vehicle are out of specification for the vehicles’ Gross Vehicle Weight Rating (“GVWR”).

EVALUATION OF RISK:

The drawbars have an elevated risk of fracture and full failure while traveling. Should the drawbars fracture or fail, the vehicle/trailer has an elevated increase to cause a crash.

SERVICE PROCEDURE:

Dealership Service Department Service procedures for addressing 2016 and 2017 model year Amera-Lite - ALDD610SA, ALDR610SA, ALDD612SA and ALDR612SA, please review and follow instructions on the Print, included with this document.

AVAILABILITY OF REMEDY:

The remedy for this recall is available upon receipt of this letter.

WHAT IS THE PART NUMBER OF THE REMEDY KIT?

143091

WHAT IS CONTAINED IN THE KIT FOR THE REMEDY?

DESCRIPTION OF PART	QUANTITY PER KIT
2" x 3" x .25" DOUBLE HOLLOW; STEEL TUBE	2

IMPORTANT SAFETY RECALL

PARTS AND RETURN:

Pictures are required of the remedy after installation.

Pictures of the remedy are a condition of payment in which must be provided with a claim against the repair code(s).

DEALER REPAIR CODES:

UNITED STATES	CANADA	REPAIR CODE	DESCRIPTION	ALLOWABLE HOUR(S)
16V682	N/A	21-000682	ADD TUBE TO A-FRAME	1.00
N/A	2016-459	21-000683	ADD TUBE TO A-FRAME	1.00

HELPFUL CONTACT INFORMATION:

Lisa Rienks	(574) 848-1335	Irienks@forestriverinc.com
-------------	----------------	----------------------------

The Recall shall be considered the utmost priority to remedy the 2016 and 2017 model year Amera-Lite - ALDD610SA, ALDR610SA, ALDD612SA and ALDR612SA in question. **The retail consumer shall not be charged** any amount of monies for remedy to their 2016 and 2017 model year Amera-Lite - ALDD610SA, ALDR610SA, ALDD612SA and ALDR612SA listed under this Recall.

If your dealership has already performed the remedy to 2016 and 2017 model year Amera-Lite - ALDD610SA, ALDR610SA, ALDD612SA and ALDR612SA, your dealership is entitled to the reimbursement as stated above by filing a claim using the indicated repair code(s). If the remedy needs to be performed on an out of warranty 2016 and 2017 model year Amera-Lite - ALDD610SA, ALDR610SA, ALDD612SA and ALDR612SA in which the VIN falls under as stated in the identified VIN listing, your dealership is entitled to the reimbursement as stated above by filing a claim using the indicated repair code(s).

Notice:

In no manner shall a Forest River Product Owner or Coachmen Product Owner be charged any fee(s) for scheduling, conduction or completion of the recall. Additionally, all dealership(s) that are Forest River and/or Coachmen dealership(s) are Federally Mandated to perform the recall once presented with this recall whether by the Owner or Dealership receipt of this letter, without denial of service to the Owner. Lastly, denial of a remedy for this recall is a Federal Violation punishable by law resulting substantial fines and/or civil penalties.

Federal Regulation requires that any lessor receiving this Recall must forward a copy of this notice to the lessee within ten days. If your dealership no longer owns this vehicle, please inform the Warranty Manager of the product listed above of the change of ownership.

Sincerely,



Forest River, Inc.
Director & Engineer
Office of Corporate Compliance

Inside DB Tube Outside DB Tube

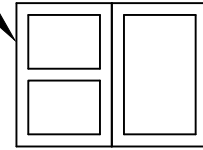

SECTION A-A

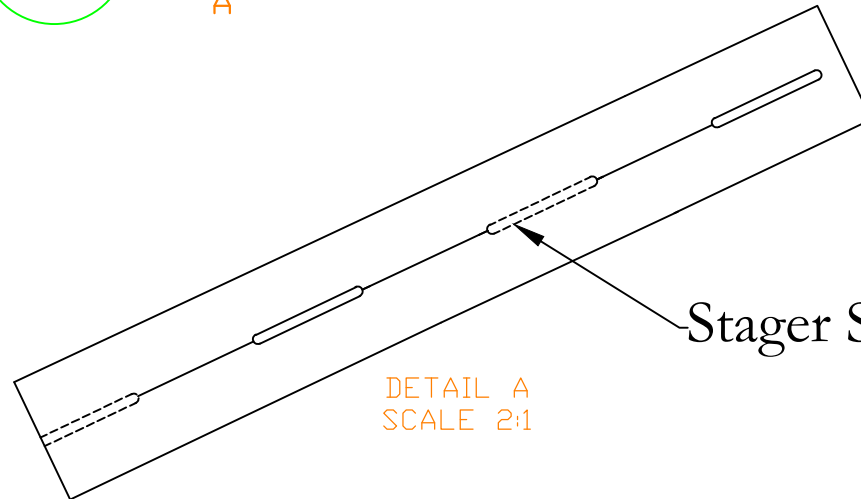
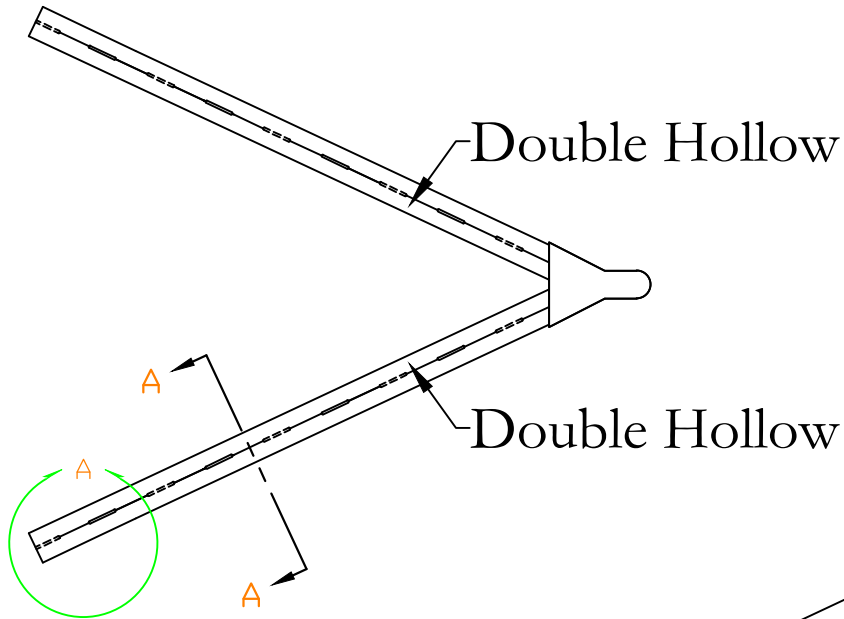

Stager Stitch Welds Top/Bottom

DETAIL A
SCALE 2:1