

LEXUS

◀ IMPORTANT UPDATE ▶

Lexus Fixed Operations

The attached Dealer Letter has been updated. Refer to the details below.

DATE	TOPIC
12/14/2016	<ul style="list-style-type: none">• Rental coverage section has been added.• The Technician Training Requirements section has been updated.
11/03/2016	<ul style="list-style-type: none">• The parts and Special Service Tools (SST) section has been updated.• The Technician Training Requirements section has been updated.
09/09/2016	<ul style="list-style-type: none">• Warranty opcodes provided.

The most recent update in the attached Dealer Letter will be highlighted with a red box.

Please review this notification with your staff to assure that all relevant personnel have been briefed regarding this subject.

Thank you for your cooperation.



August 11, 2016

Subject: Safety Recall GLK - *Remedy Notice*
2010 Model HS 250h Vehicles
Rear Lower Suspension Arm No. 1 Assemblies

Dear Dealer Principal:

On August 10th, Lexus filed an amended Defect Information Report (DIR) with the National Highway Traffic Safety Administration (NHTSA) informing the agency of our intent to change the remedy on certain 2010 model year HS 250h vehicles.

Background

Safety Recall GLK applies to a specific population of 2010 model year HS 250h vehicles involved in Lexus' previous recall related to the Rear Lower Suspension Arm No. 1. The previous recall included the inspection of the suspension arm assemblies for corrosion and, if necessary, replacement of the suspension arm assemblies on the subject vehicles. In some cases, corroded arms may not have been identified and replaced. Moving forward, any vehicle that has not already had both rear lower suspension arms replaced under the previous recall remedy are now included in this new Safety Recall. Customers with these vehicles will be asked to return to the dealership for the revised remedy procedure. The remedy will be performed at **NO CHARGE** to the customer.

Condition

In the earlier action, if the nuts for adjusting rear wheel alignment were improperly tightened when an alignment was performed, rust could form on suspension arm threads. If this occurs, and if the condition is not identified and remedied during servicing or repair under the existing remedy procedure, the threads can wear over time, causing the arm to separate, which could result in a loss of vehicle control.

Remedy

The remedy will involve the replacement of **BOTH** suspension arms and encasing them in epoxy. An alignment will be performed, as well, and warning labels will be applied.

Number and Identification of Covered Vehicles

There are approximately 8,400 2010 model year HS 250h vehicles covered by this Safety Recall in the U.S. There are approximately 30 vehicles covered by this Safety Recall in Puerto Rico.

Model	Model Year	Production Period
HS 250h	2010	July, 2009 through Late August, 2010

Owner Letter Mailing Date

Lexus will notify owners in September, 2016.

Lexus tries very hard to obtain current customer name and address information when mailing owner letters. In the event your dealership receives a notice for a vehicle that was sold prior to the Safety Recall announcement, it is the dealership's responsibility to forward the owner letter to the customer who purchased the vehicle.

Please note that only owners of the covered vehicles will be notified. If your dealership is contacted by an owner who has not yet received a notification, please **verify eligibility by confirming through TIS prior to performing repairs**. Dealers should perform the repair as outlined in the Technical Instructions found on TIS.

Pre-Owned Vehicles in Dealer Inventory

Lexus requests that dealers do not deliver any pre-owned vehicles in dealer inventory that are covered by a Safety Recall unless the defect has been remedied.

Also, as a reminder, Lexus L-Certified policy prohibits the certification of any vehicle with an outstanding Special Service Campaign or Safety Recall. Thus, no affected units should be sold or delivered as an L-Certified vehicle until the Safety Recall remedy has been completed on that vehicle.

Rental Vehicle Reimbursement Procedure

If parts are not available, the customer may be offered a rental vehicle. Rental reimbursement instructions will be provided as soon as it become available.

Rental vehicle reimbursement will be made at a maximum rate of \$45 per day.

Technician Training Requirements

The repair quality of covered vehicles is extremely important to Lexus. All dealership technicians performing this repair are required to successfully complete the most current version of the E-Learning course "Safety Recall and Service Campaign Essentials" and must also successfully complete E-Learning course LSCGLK. To ensure that all vehicles have the repair performed correctly, technicians performing this repair are required to meet the training requirements described below.

The training requirements that were in effect at the initial launch of GLK in August, 2016 will remain applicable until December 18, 2016. In November 2016 a new eLearning Module LSCGLK will be available, an announcement will be sent informing technicians when this course is available. Starting on December 19, 2016 the training requirements will be updated and all technicians performing GLK **MUST** meet the updated training requirements.

Initial Training Requirements

All dealership technicians performing this recall are required to successfully complete the most current version of the E-Learning course "Safety Recall and Service Campaign Essentials" To ensure that all vehicles have the repair performed correctly; only Lexus technicians with successful completion of L453, LSC13C and hold at least one of the following certification level are approved to conduct this repair:

- Senior
- Master
- Diagnostic Specialist

Updated Training Requirements – In effect starting 01/20/2017

All dealership technicians performing this repair are required to successfully complete the most current version of the E-Learning course "Safety Recall and Service Campaign Essentials". To ensure that all vehicles have the repair performed correctly; Lexus technicians performing this repair **must successfully complete e-learning LSCGLK**, received the hands on training LSCGLKH, completed L453 and hold at least one of the following certification levels:

- Senior
- Master
- Diagnostic Specialist

It is the dealership's responsibility to select technicians with the above certification level or greater to perform this repair. Carefully review your resources, the technician skill level, and ability before assigning technicians to this repair. It is important to consider technician days off and vacation schedules to ensure there are properly trained technicians available to perform this repair at all times.

Always check which technicians can perform the recall remedy by logging on to <https://www.utodealerreports.com>. It is the dealership's responsibility to select technicians with the above certification level or greater to perform this repair. Carefully review your resources, the technician skill level, and ability before assigning technicians to this repair. It is important to consider technician days off and vacation schedules to ensure there are properly trained technicians available to perform this repair at all times.

Remedy Procedures

Please refer to TIS for Technical Instructions on repair. Conduct all non-completed Safety Recalls and Service Campaigns on the vehicle during the time of appointment.

Repair Quality Confirmation

The repair quality of covered vehicles is extremely important to Lexus. To help ensure that all vehicles have the repair performed correctly, please designate at least one associate (someone other than the individual who performed the repair) to verify the repair quality of every vehicle prior to customer delivery.

Parts Ordering Process

Due to potentially limited availability, the parts may have been placed on either Manual Allocation Control (MAC) or Dealer Ordering Solutions (DOS). As the parts inventory changes, the ordering process may change. Please check the Lexus Special Activities MAC/DOS report on the Lexus Customer Services website for the most up-to-date parts ordering information.

As always, if a customer experiences the condition described, dealers should conduct appropriate diagnosis and order the applicable parts.

	Part Description	Quantity
91672-L1270	Bolt (Suspension Arm to Rear Sub-Frame)	2 per vehicle
90080-17221	Nut	2 per vehicle
04002-36112	Rear Suspension Arm No. 1 Kit*	2 per vehicle
*The kit above includes the following parts:		
48710-12270	Rear Lower Suspension Arm No. 1	1
90179-12027	Nut	1

The above parts should be replaced on all vehicles when performing the repair.

Special Service Tools

The SSTs on the following page are required for this Safety Recall. They were previously sent to your dealership at the launch of Safety Recall CLE in August, 2013.

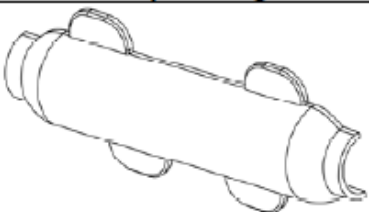
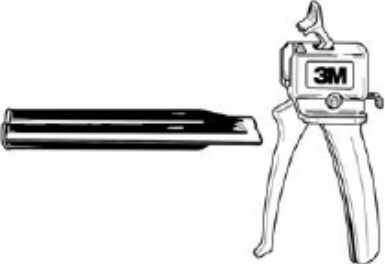
Name	Sample Image	Qty.
Epoxy Mold		4 halves / 2 completed molds
Epoxy Applicator		1

The SST below was provided to your dealership in November 2016. This tool is being introduced to assist technicians when performing the repair.

Name	Sample Image	Qty.
Rear Control Arm Torque Fixture		1

Material Ordering Information

The epoxy kit required for each vehicle can be ordered through the Lexus Complete Maintenance Care Program (LCMC) and will be drop shipped from AMREP.

Model Application	Epoxy Kit Part Number	Chemical Name	Quantity/Vehicle
HS 250h	00289-SW1LX-DS	Epoxy Kit	1 kit per vehicle
<p><u>The kit above includes the following components:</u> 50 mL Tube of Epoxy - Quantity 1 Epoxy Mixing Nozzle - Quantity 1 Safety Recall Caution Labels - Quantity 2</p>			

The required Mold Release Spray can be ordered through the LCMC program and will be drop shipped from AMREP.

Model Application	Mold Release Spray Part Number	Chemical Name	Quantity/Vehicle
HS 250h	00289-HKLMR-DS	Mold Release Spray	1 can per 100 vehicles
<p>Note: When ordering a quantity of 1 your dealership will be shipped 1 can of Mold Release Spray.</p>			

Warranty Reimbursement Procedure

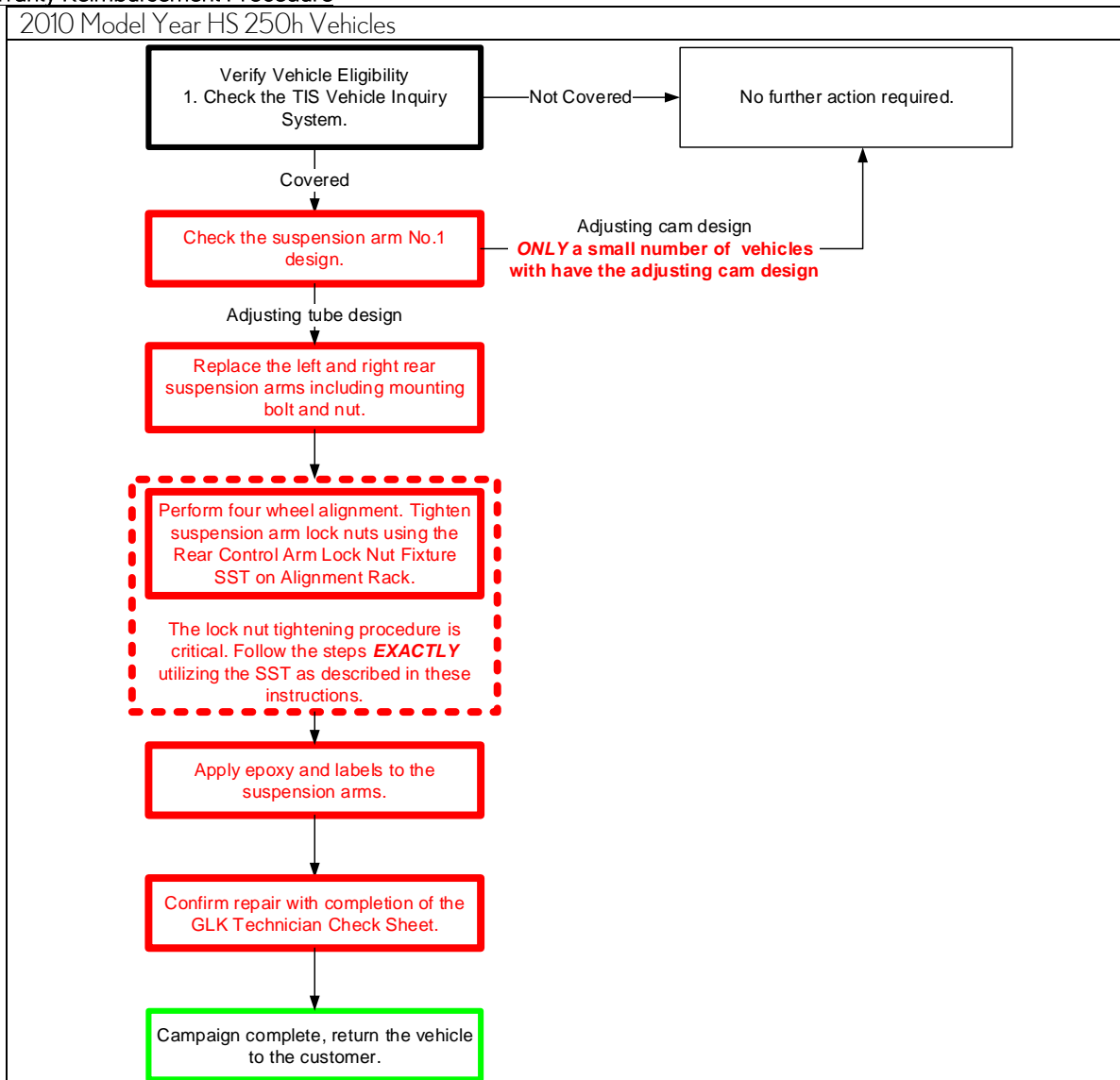

Model	Op. Code	Description	Flat Rate Hour
HS 250h	CGG58C	Replace Both Arms, Perform Alignment, Apply Epoxy and Warning Labels	<i>2.6 hr/vehicle</i>

- The flat rate times include 0.1 hours for administrative cost per unit for the dealership.
- The flat rate time for alignment is included in opcode CGG58C.
- The cost of the epoxy kit can be claimed by part number under opcode CGG58C.
- The cost of the mold release spray can be claimed under opcode CGG58C as sublet type "ZZ" at a maximum rate of \$0.25 per vehicle.

In limited cases where the Rear Suspension Arm No. 1 is of the adjustment cam design type the following operation code should be used.

Model	Op. Code	Description	Flat Rate Hour
HS 250h	CGG58D	Check suspension arm assembly	<i>0.2 hr/vehicle</i>

- The flat rate time include 0.1 hours for administrative cost per unit for the dealership.

Lexus' usual customer care amenities of car wash and fuel tank fill apply to this Safety Recall. Additionally, one day of rental vehicle expense (to a maximum of \$35/day) or the cost of pick-up and redelivery of the customer's vehicle may be claimed if required.

Customer Reimbursement

Reimbursement consideration instructions will be included in the Owner Letter.

Media Contacts

It is imperative that all media contacts (local and national) receive a consistent message. In this regard, all media contacts must be directed to Victor Vanov (469) 292-1318 in Toyota Corporate Communications. (Please do not provide this number to customers. Please provide this contact to only media associates.)

Customer Contacts

A Q&A has been attached for your use in the event you receive a customer contact. If a customer has further questions please direct the inquiry to the Customer Assistance Center at 1-800-255-3987.

Please review this notification with your staff to assure that all relevant personnel have been briefed regarding this subject.

Thank you for your cooperation.

Enclosures

Cc: Customer Satisfaction Manager
 General Manager
 Parts Manager
 Pre-Owned Manager
 Sales Manager
 Service Manager



Safety Recall GLK - Remedy
2010 Model Year HS 250h
Rear Lower Suspension Arms (No.1) Assemblies

Frequently Asked Questions
Published August 11, 2016

Background

Safety Recall GLK applies to a specific population of 2010 model year HS 250h vehicles involved in Lexus' previous recall related to the Rear Lower Suspension Arm No. 1. The previous recall included the inspection of the suspension arm assemblies for corrosion and, if necessary, replacement of the suspension arm assemblies on the subject vehicles. In some cases, corroded arms may not have been identified and replaced. Moving forward, any vehicle that has not already had both rear lower suspension arms replaced under the previous recall remedy are now included in this new Safety Recall. Customers with these vehicles will be asked to return to the dealership for the revised remedy procedure. This remedy will be performed at **NO CHARGE** to the customer.

Q1: What is the condition?

A1: In the earlier action, if the nuts for adjusting rear wheel alignment were improperly tightened when an alignment was performed, rust could form on suspension arm threads. If this occurs, and if the condition is not identified and remedied during servicing or repair under the existing remedy procedure, the threads can wear over time, causing the arm to separate, which could result in a loss of vehicle control.

Q2: Why is Safety Recall GLK superseding the previous Safety Recall?

A2: Lexus received reports indicating that some vehicles experienced symptoms of the recalled condition after being inspected or repaired under the previous Safety Recall.

Q2a: Why were both suspension arms not replaced in the previous repairs?

A2a: The previous campaign involved an inspection to determine if arms exhibited signs of corrosion or other damage. Arms judged to be serviceable were not replaced.

Q3: What is Lexus going to do?

A3: Lexus will send an owner notification for Safety Recall GLK by first class mail in September of 2016 advising customers to return to the dealership for the revised repair procedure. The revised remedy will be performed at **NO CHARGE** to the customer.

Q4: What is the revised remedy procedure?

A4: Lexus dealers will be requested to replace BOTH the rear lower suspension arms using the newly developed procedure. After the replacement, the rear suspension alignment will be set and the arms will be sealed with an epoxy. Labels will also be applied stating the arm is no longer adjustable.

Q4a: What is the purpose of the epoxy?

A4a: The epoxy is being applied to make the arm non-adjustable and prevent future improper servicing. The epoxy will also seal the arm, preventing water from entering and causing the formation of rust.

Q4b: How will I have my alignment adjusted in the future?

A4b: During the revised remedy repair Lexus will set the rear alignment of your vehicle to the proper specification. Future vehicle alignment adjustment and steering wheel centering will be performed using the front wheel adjustments only. This is similar to many other vehicles. If the rear wheel

alignment shifts out of specification, rear suspension arms or other components may need to be replaced.

Q5: Are there any warnings that this condition exists?

A5: Yes, if a Rear Lower Suspension Arm No. 1 becomes loose, the driver may notice an abnormal noise from the rear of the vehicle and unstable steering feeling.

Q5a: What should I do if I hear an abnormal noise from the rear of the vehicle or experience unstable steering feel?

A5a: If you hear an abnormal noise from the rear of the vehicle or have an unstable steering feel, you should contact any authorized Lexus dealer for diagnosis, and if applicable, repair. If the condition is related to this Safety Recall the repair will be performed at **NO CHARGE** to you.

Q6: Which and how many vehicles are covered by this Safety Recall?

A6: There are approximately 8,400 Lexus HS 250h vehicles covered by this Safety Recall in the U.S.

Model Name	Model Year	Production Period	Number of Vehicles (Approx.)
HS250	2010	July, 2009 through Late August, 2010	8,400

Q6a: Are there any other Toyota or Lexus vehicles covered?

A6a: Yes, there are approximately 329,000 Toyota 2006 to Early 2011 Model Year RAV4 Vehicles covered by this Safety Recall.

Q7: What should I do when I receive an owner letter?

A7: Please contact your local authorized Lexus dealer and make an appointment to have the repair procedure applied to the Rear Lower Suspension Arm No. 1 Assemblies of your vehicle.

Q8: How long will the repair take?

A8: The repair takes approximately 3 hours. However, depending upon the dealer's work schedule, it may be necessary to make the vehicle available for a longer period of time.

Q9: What if I previously paid for repairs related to this Safety Recall?

A9: Reimbursement consideration instructions will be provided in the owner letter.

Q10: How does Lexus obtain my mailing information?

A10: Lexus uses an industry provider who works with each state's Department of Motor Vehicles (DMV) to receive registration or title information, based upon the DMV records. Please make sure your registration or title information is correct.

Q11: What if I have additional questions or concerns?

A11: Owners with questions or concerns are asked to please contact the Customer Assistance Center at 1-800-255-3987, Monday through Friday, 5:00 am to 6:00 pm, or Saturday 7:00 am through 4:00 pm Pacific Time.

Certain 2010 Model Year HS 250h
Rear Lower Suspension Arm (No. 1) Assemblies
SAFETY RECALL NOTICE *(Remedy Notice)*
This notice applies to your vehicle: [VIN]
NHTSA Recall No. 16V-596

URGENT SAFETY RECALL
This is an important Safety Recall.
The remedy will be performed at
NO CHARGE to you.

Dear Lexus Customer:

This notice is sent to you in accordance with the requirements of the National Traffic and Motor Vehicle Safety Act. Lexus has decided that a defect, which relates to motor vehicle safety, exists in certain 2010 Model Year HS 250h Vehicles.

You received this notice because our records, which are based primarily on state registration and title data, indicate that you are the current owner.

What is the background?

This Safety Recall applies to a specific population of 2010 model year HS 250h vehicles involved in Lexus's previous recall related to the Rear Lower Suspension Arm No. 1. The previous recall included the inspection of the suspension arm assemblies for corrosion and, if necessary, replacement of the suspension arm assemblies on the subject vehicles. In some cases, corroded arms may not have been identified and replaced. Moving forward, any vehicle that has not already had both rear lower suspension arms replaced under the previous recall remedy are now included in this new Safety Recall. This includes vehicles not previously returned to a dealer for inspection.

What is the condition?

In the subject vehicles, if the nuts for adjusting rear wheel alignment were improperly tightened when an alignment was performed, rust could form on suspension arm threads. If this occurs, and if the condition is not identified and remedied during servicing or repair under the existing remedy procedure, the threads can wear over time, causing the arm to separate, which could result in a loss of vehicle control.

What will Lexus do?

Any authorized Lexus dealer will replace both suspension arms, perform an alignment, and encase the suspension arms in epoxy at **NO CHARGE** to you.

What should you do?

This is an important Safety Recall.

Please contact any authorized Lexus dealer to schedule an appointment to have the remedy performed as soon as possible.

Until then, if you hear an abnormal noise from the rear of the vehicle or have an unstable steering feel, you should contact any authorized Lexus dealer immediately. If the condition is related to this Safety Recall, the repair will be performed at **NO CHARGE** to you.

The remedy will take approximately 3 hours. However, depending on the dealer's work schedule, it may be necessary to make your vehicle available for a longer period of time.

What if you have other questions?

- *Your local Lexus dealer will be more than happy to answer any of your questions.*
- If you require further assistance, you may contact the Lexus Customer Assistance Center at 1-800-255-3987 Monday through Friday, 5:00 am to 6:00 pm, Saturday 7:00 am to 4:00 pm Pacific Time.

If you believe that the dealer or Lexus has failed or is unable to remedy the defect within a reasonable time, you may submit a complaint to the Administrator, National Highway Traffic Safety Administration, 1200 New Jersey Avenue S.E., Washington, D.C. 20590, or call the toll free Vehicle Safety Hot Line at 1-888-327-4236 (TTY: 1-800-424-9153), or go to <http://www.safercar.gov>.

If you would like to update your vehicle ownership or contact information, you may do so by registering at www.Lexus.com/ownersupdate. You will need your full 17-digit Vehicle Identification Number (VIN) to input the new information.

If you are a vehicle lessor, Federal Law requires that any vehicle lessor receiving this recall notice must forward a copy of this notice to the lessee

within ten days.

We have sent this notice in the interest of your continued satisfaction with our products, and we sincerely regret any inconvenience this condition may have caused you.

Thank you for driving a Lexus.

Sincerely,

LEXUS, a DIVISION OF TOYOTA MOTOR SALES, U.S.A., INC.

What if you have previously paid for repairs to your vehicle for this specific condition?

If you have previously paid for repair to your vehicle for this specific condition prior to receiving this letter, please mail a copy of your repair order, proof-of-payment and ownership information to the following address for reimbursement consideration:

Lexus Customer Assistance Center
Lexus, a Division of Toyota Motor Sales, USA, Inc.
19001 S. Western Avenue
L201
SSC/CSP Reimbursements
Torrance, CA 90509

Sample