



www.smeal.com / **HEADQUARTERS:** 610 W 4th St. - P.O. Box 8 Snyder, NE 68664 / PH: (402) 568-2224 FX: (402) 568-2346
 www.ustanker.com / **PLANT:** 1827 Hobbs Dr. Delavan, WI 53115 / PH: (262) 763-6220 FX: (262) 725-7000
 www.laddertower.com / **PLANT:** 68 Cocalico Creek Rd Ephrata, PA 17522 / PH: (717) 859-5472 FX: (717) 859-3517

Date: August 16, 2016

Safetek Emergency Vehicles Ltd.
 30686 A Matsqui Place
 Abbotsford, BC V2T 6L4

Dear Wayne Stevens:

This notice is sent to you in accordance with the National Traffic and Motor Vehicle Safety Act. Waterous Company has decided that a safety related defect may exist in certain model C20 and C21 split-shaft transmissions and model TC20 and TC21 PTO split-shaft transmissions manufactured from April 9, 2015, to April 20, 2016. This condition could potentially result in the inability to shift the apparatus from road to pump mode.

You are receiving this letter because our manufacturing records indicate the following Chassis VIN number/numbers are affected by the National Traffic and Motor Vehicle Safety Act recall # 16E059.

<u>SO#</u>	<u>VIN #</u>	<u>Customer</u>
4419		Brantford Fire Department P.O. Box 61 Brantford ON N3T 5M3
4436		District of West Kelowna Fire Rescue 2760 Cameron Road West Kelowna BC V1Z2T6
4441		Fire Vehicle and Equipment Maintenance 1755 18 Avenue NE Calgary AB T2E 8T8
4442		Fire Vehicle and Equipment Maintenance 1755 18 Avenue NE Calgary AB T2E 8T8
4443		Fire Vehicle and Equipment Maintenance 1755 18 Avenue NE Calgary AB T2E 8T8
4444		Fire Vehicle and Equipment Maintenance 1755 18 Avenue NE Calgary AB T2E 8T8
4445		Fire Vehicle and Equipment Maintenance 1755 18 Avenue NE Calgary AB T2E 8T8

- 4446 Fire Vehicle and Equipment Maintenance
1755 18 Avenue NE
Calgary AB T2E 8T8
- 4447 Fire Vehicle and Equipment Maintenance
1755 18 Avenue NE
Calgary AB T2E 8T8
- 4448 Fire Vehicle and Equipment Maintenance
1755 18 Avenue NE
Calgary AB T2E 8T8
- 4449 Fire Vehicle and Equipment Maintenance
1755 18 Avenue NE
Calgary AB T2E 8T8
- 4451 Fire Vehicle and Equipment Maintenance
1755 18 Avenue NE
Calgary AB T2E 8T8
- 4467 Justice Institute of British Columbia
715 McBride Boulevard
New Westminster BC V3L 5T4
- 4493 Cowichan Bay Improvement District
PO Box 1039
Duncan BC V9L3Y2
- 4496 Saanich, District of
770 Vernon Avenue
Victoria BC V8X2W7
- 4503 Vancouver, City of
453 West 12th Avenue
Vancouver City Hall
Vancouver BC V5Y 1V4
- 4504 Vancouver, City of
453 West 12th Avenue
Vancouver City Hall
Vancouver BC V5Y 1V4

Please contact the Fire Departments listed above to make a service appointment to have the Waterous Retrofit Repair kit installed. We have replacement Waterous Retrofit Repair kits available now to ship immediately. The recall remedy consists of removing the shift unit assembly in the affected split-shaft transmissions and replacing the shift unit's clevis pin and retaining rings with a shoulder bolt and locking nut.

Each Waterous Retrofit Repair kit will be individually packaged and will include detailed installation instructions (see attached). It will take approximately one hour of service time to perform the remedy.

IMPORTANT

1. Contact your customers list above to make a service appointment to have these trucks repaired.
2. Order the Waterous Retrofit Repair kits through the Smeal Parts Department
3. Complete and submit the Waterous "Certificate of Remedy and Disposal" form and invoice to service @ smeal.com.
4. INCLUDED IN THE ATTACHED INSTRUCTIONS IS A CERTIFICATE OF REMEDY AND DISPOSAL FORM THAT MUST BE FILLED OUT AND RETURNED TO SMEAL FIRE APPARATUS. Upon receipt of each completed certificate, Smeal will credit your account for \$300.00 as follows:

2 hours travel time @ \$100/hour	\$200
1 hour repair time @ \$100/hour	<u>\$100</u>
Total	\$300

If your customer has already performed this remedy, your customer may be eligible to receive reimbursement for the cost of performing the remedy which is the subject of this recall. Waterous Company will handle reimbursements for remedies performed prior to this notice through the Waterous Returned Material Authorization (RMA) process. To initiate the RMA process, please contact Mark Blake Senior Technical Service Specialist, Phone 651-450-5067, mablake@waterousco.com. Our service specialist will provide you with an RMA number to move through the reimbursement process.

If you believe there is a failure to remedy this defect without charge and within a reasonable time, you may submit a written complaint to the Administrator, National Highway Traffic Safety Administration, 1200 New Jersey Avenue, SE, Washington, D.C. 20590; or call the toll-free Vehicle Safety Hotline at 1-888-327-4236 (TTY: 1-800-424-9153); or go to <http://www.safercar.gov>.

We apologize for any inconvenience this safety recall may cause, but customer safety is our first concern.

Sincerely,



John Rasmus
Director of Customer Service
Smeal Fire Apparatus Co.
Office: 402-218-1541
Email: john@smeal.com

K 1216

Pneumatic Shift Unit

Clevis Pin Retrofit Kit Instructions NHTSA Recall 16E059

Consists of the following:

Part Number	Description	Qty
53322	Shoulder - Bolt, 1/2" x 1-1/4"	1
W3729-3	O-ring, 2"	1
W79006	Locknut – FlexTop, 3/8-16 UNC	1

Index:

Description	See Page
Clevis Pin Retrofit Instructions	2-6
Certificate of Remedy and Disposal	7

Waterous Company,
125 Hardman Avenue South,
South St. Paul, MN 55075 www.waterousco.com
Email: service@waterousco.com

Pneumatic Shift Unit Clevis Pin Retrofit Kit Instructions

⚠ WARNING

Rotating Parts Hazard or Unexpected Truck Movement. May result in serious personal injury or death.

Stop the engine, set parking brake and chock the wheels before attempting to remove or repair the transmission.

1. Disconnect wiring harness, air lines, and manual override linkage (if equipped). This may not be required if air lines and harness allow clevis modification without removal.

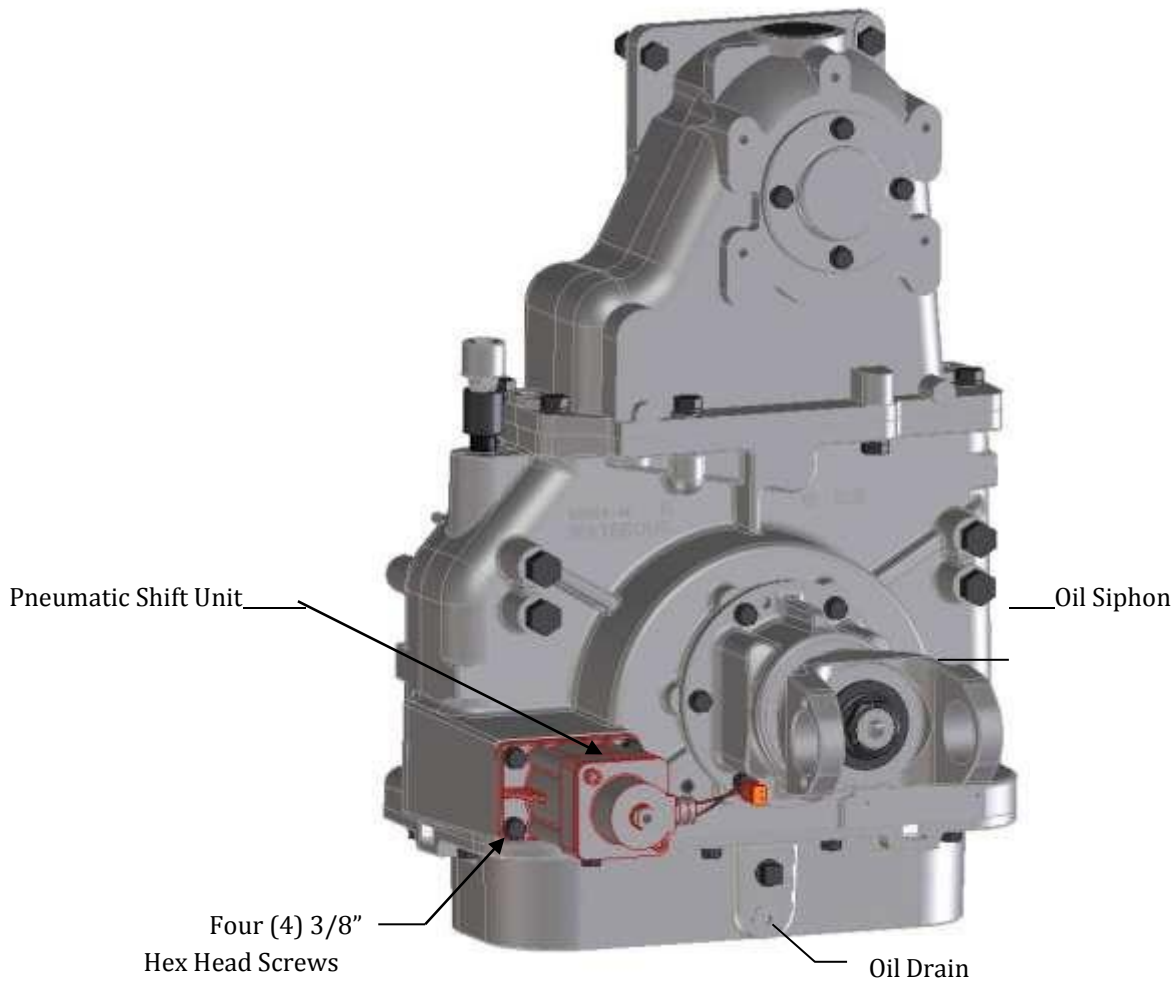

2. Drain or siphon the case lubricant below shift unit level (approximately 3.25 qts / 3.075liters)

Pneumatic Shift Unit Clevis Pin Retrofit Kit Instructions

3. Place shift unit in ROAD mode by pushing override rod in.
4. Remove the four (4) 3/8-16 x 1 in. mounting screws and washers.
5. Pull shift unit straight back as far as possible.
6. Rotate shift unit towards case to disengage clevis from shift fork.

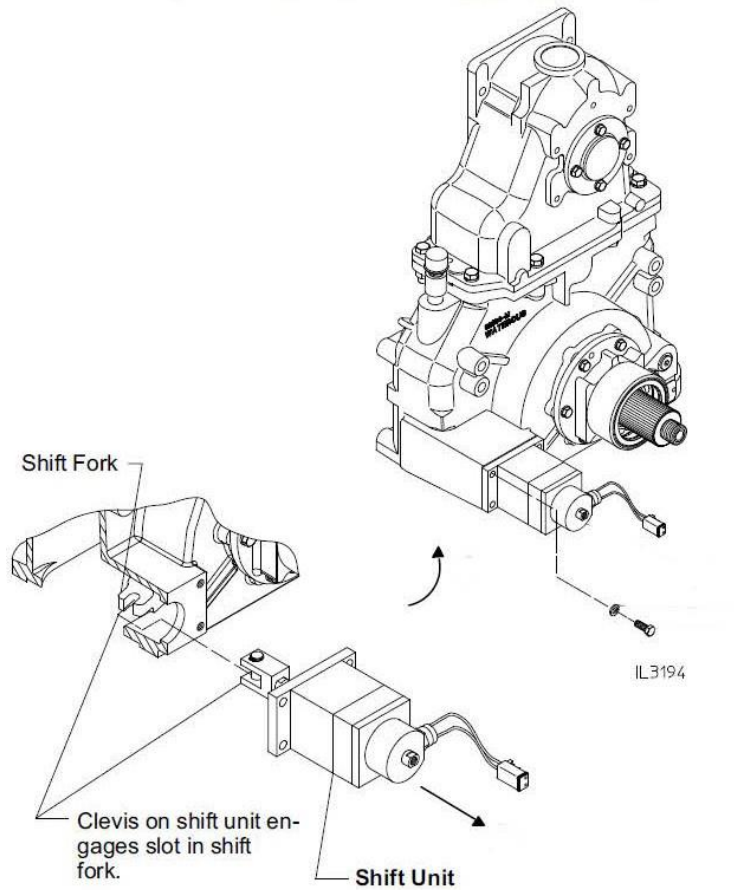

7. Record the shift unit date code stamped into the back of the shift unit as shown below and enter into Certificate of Remedy and Disposal.



Pneumatic Shift Unit Clevis Pin Retrofit Kit Instructions (con't)

8. Remove one retaining ring from the clevis pin and remove pin as shown below.

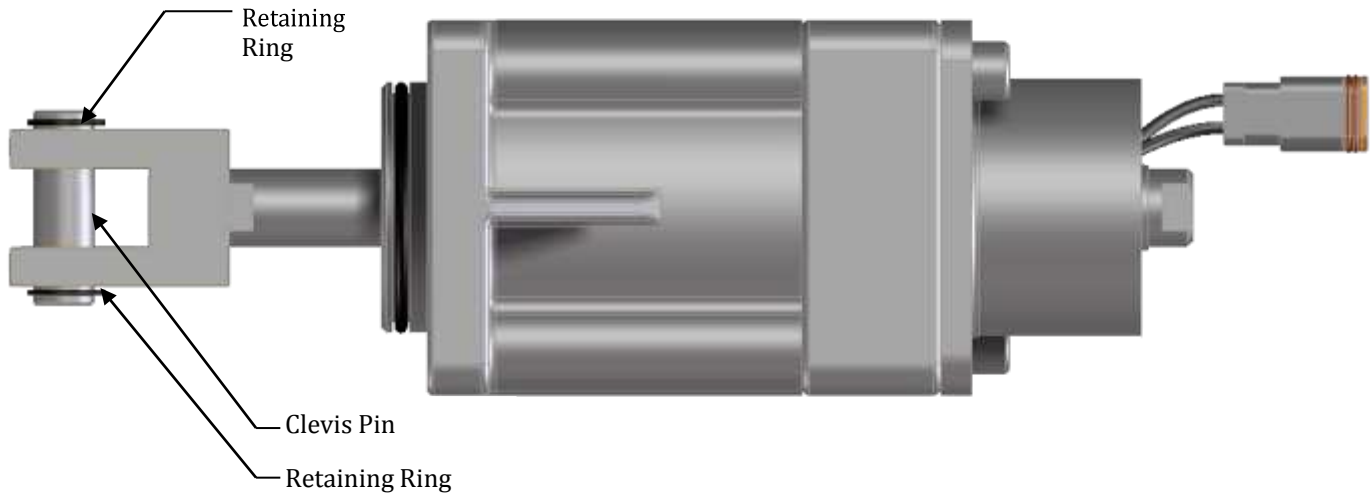

9. Remove and replace shift unit O-ring, coating O-ring with grease upon replacement.
10. Install shoulder bolt and locknut as shown below. Head of shoulder bolt must be on top. Torque to 170 inch-lbs. / 19.2 Nm.

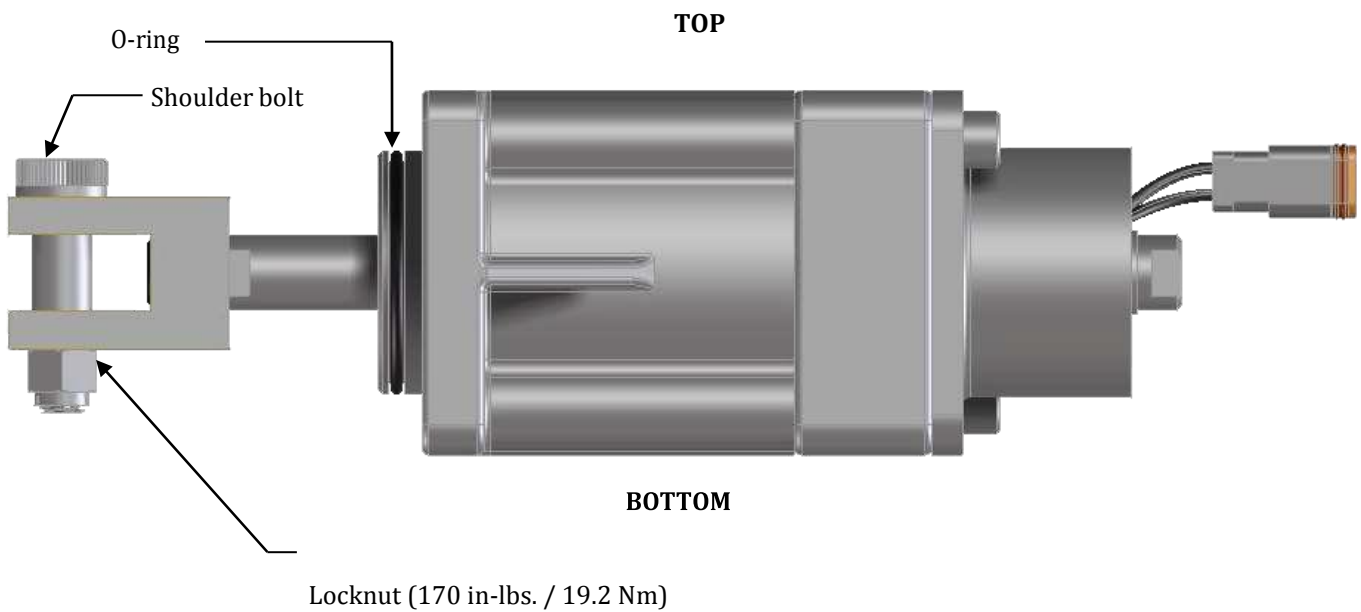

Pneumatic Shift Unit Clevis Pin Retrofit Kit Instructions (con't)

11. Place shift unit in ROAD mode by pushing override rod in.
12. Place shift fork in PUMP mode by pulling fork arm towards end of case where the shift unit mounts.
13. Rotate shift unit towards case and engage clevis in shift fork slot.
14. Push shift unit straight back in until flange contacts case.
15. Install four (4) 3/8-16 x 1 in. screws and lockwashers. Torque to 31 lb-ft/42 Nm.

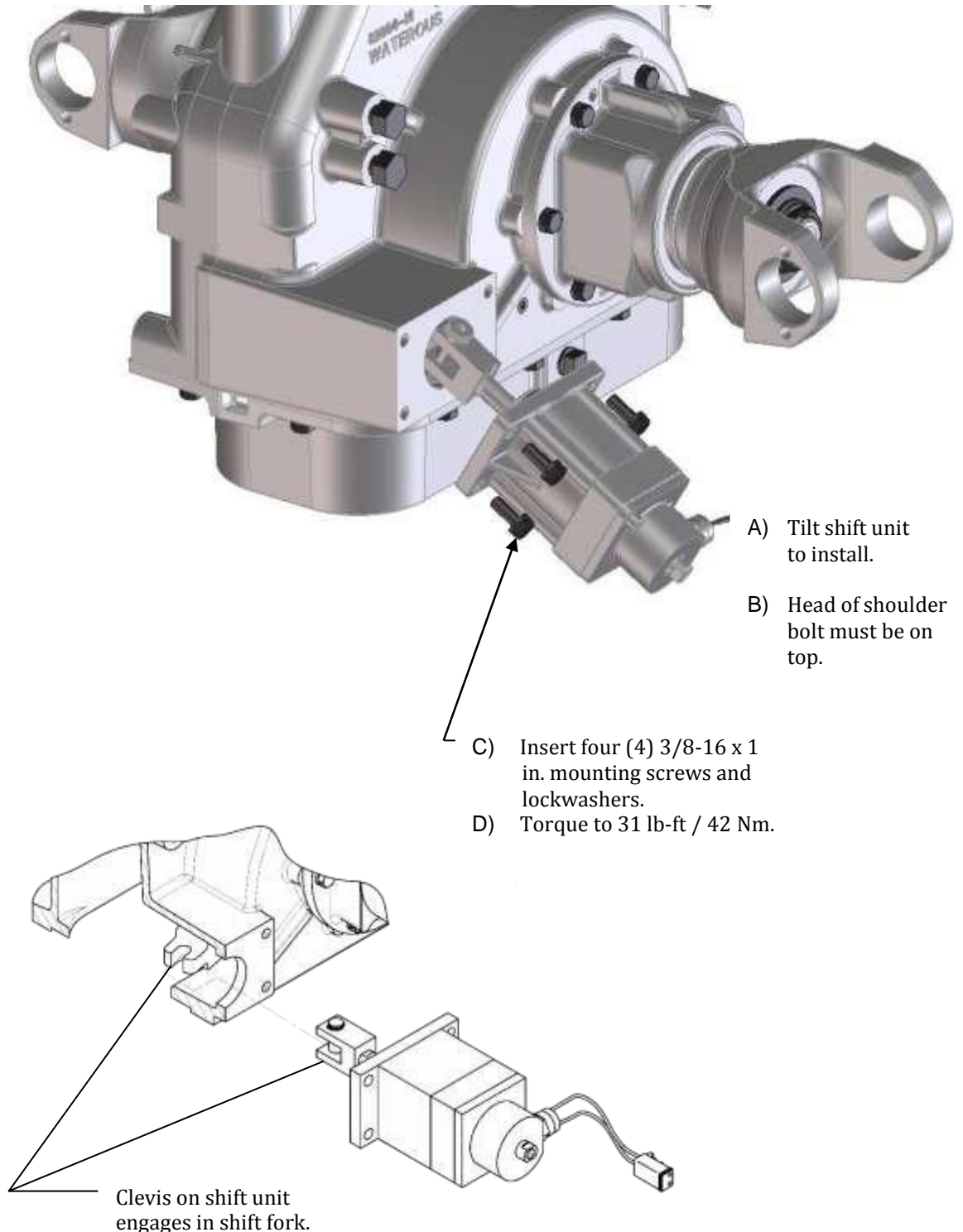

IL3194

Pneumatic Shift Unit Clevis Pin Retrofit Kit Instructions (con't)

16. Refill case lubricant to proper level.

- a. Fill the transmission through the oil level hole or by removing the breather and adding fluid through the opening. Any type of automatic transmission fluid (ATF) may be used. Capacity is approximately 6 quarts. Fill to the bottom of the threads in the oil level port.
- b. Re-check all fasteners for tightness.
- c. Check for fluid checks.

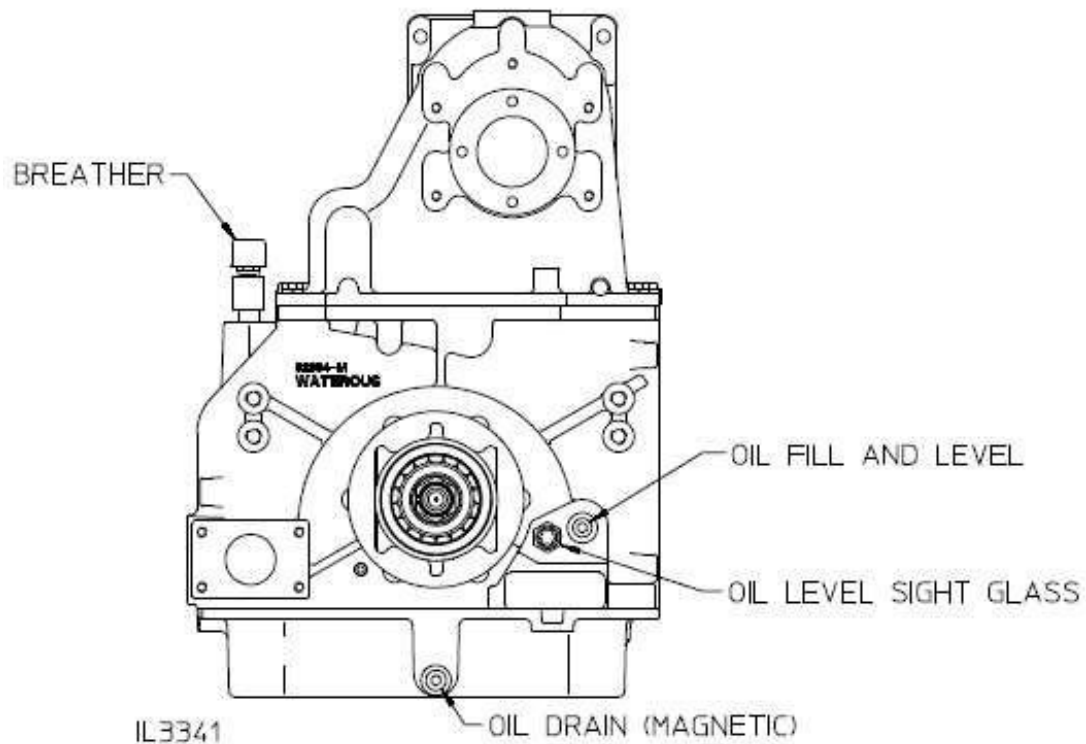

17. Reconnect wiring harness, air lines and manual override linkage (if equipped), if removal was required.

18. Operate shift unit to test actuation and pump engaged light.

19. Complete the Certificate of Remedy and Disposal and fax to Waterous Company at +1(651) 450-5090 or email to service@waterousco.com



Waterous Company
125 Hardman Avenue South
South St. Paul, MN 55075

**Certificate of Remedy and Disposal
Clevis Pin and Retaining Rings
NHTSA Recall 16E059**

REPAIR FACILITY NAME: _____
ADDRESS: _____
CITY: _____
STATE: _____ ZIP: _____
CONTACT NAME: _____
CONTACT TITLE: _____
CONTACT DAYTIME PHONE NUMBER: _____
CONTACT EMAIL ADDRESS: _____

I hereby certify the NHTSA 16E059 remedy has been performed as directed and the clevis pin and retaining rings for the unit identified below have been discarded.

PRINT NAME: _____
SIGNATURE: _____
DATE SUBMITTED: _____

Pump Transmission Serial Number	Shift Unit Date Code*

* The shift unit date code is the 5 character code (YY W XX) on the front surface mounting flange.

NOTICE: Please fax this completed document to Waterous Company at +1(651) 450-5090 or email to service@waterousco.com.

Questions: Contact Mark Blake at +1(651) 450-5067 or e-mail at mablake@waterousco.com.