

# SAFETY RECALL



INFINITI

EMPOWER THE DRIVE

## CAMPAIGN BULLETIN

### Takata Passenger Airbag Inflator Voluntary Safety Recall Campaign

Reference: R1622/R1704 – Final Remedy  
Date: February 8, 2017

**Attention: Retailer Principal, Sales, Parts and Service Managers**

The R1622: Revision 2 announcement from December 21, 2016 has been incorporated into this announcement. Please discard previous versions of the R1622 bulletin.

Affected Models/Years:	Affected Population:	Retailer Inventory:	SERVICE COMM Activation date:	Stop Sale In Effect
2006-2008 FX35/FX45	35,785	NA	December 9, 2016	<b>YES</b>
2003-2005 FX35/FX45	44,324		February 8, 2017	
2008-2010 M35/M45	~18,504		December 9, 2016	
2006-2007 M35/M45	~57,606		February 8, 2017	
2003-2004 I35	~9,797		February 8, 2017	

#### \*\*\*\*\* Campaign Summary \*\*\*\*\*

Infiniti is committed to the safety and security of our clients and their passengers. As previously announced in July 2016, Infiniti is conducting a Voluntary Safety Recall Campaign on the affected vehicles to replace passenger airbag inflators or module assembly. Infiniti clients received interim recall notification letters advising them of the recall.

At this time, the final remedy parts are available for the vehicles listed above. Infiniti began notifying affected owners that final remedy parts were available in December, 2016. Infiniti expects to conclude owner notifications in March, 2017.

#### \*\*\*\*\* What Retailers Should Do \*\*\*\*\*

1. Verify if vehicles are affected by this Voluntary Safety Recall Campaign using Service Comm I.D. R1622 or R1704.
  - **R1622** = Vehicles previously identified under R1618 or R1619 that did not receive an interim repair
  - **R1704** = Vehicles previously identified under R1618 or R1619 that received an interim repair, but has not yet received the final repair.
2. Retailers should not sell, lease, trade, rent or loan any vehicles in retailer inventory affected by this recall campaign until after the vehicle has been repaired.
3. Retailers should use the following campaign repair bulletins to remedy any vehicles subject to this campaign:
  - R1622**
    - ITB16-049 - 2008-2010 M(Y50)
    - ITB16-050 - 2006-2008 FX35/45 (S50)

- ITB17-003 - 2003-2004 I35 (CA33), 2003-2005 FX35/45 (S50), and 2006-2007 M35/45 (Y50)  
R1704

- Campaign bulletin is currently under development, please use attached repair procedure.

**NOTE:** Should damage to the instrument panel occur during repair on an M35/45 sedan, order the appropriate instrument panel and replace.

CM I.D.	DESCRIPTION	OP CODE	FRT
R1622	If Dash pad replacement required 2006-2010 (M35/M45) (Y50)	R16227	0.1 hrs.

- As a best practice, retailers should take high quality pictures of the instrument panel before and after performing the campaign to capture the entire instrument panel from side to side (minimum of 4 pictures moving left to right is recommended).
- If the client is not already in a long term rental, **short-term rental** is available while parts are on order. Expense code noted below can be claimed with the campaign repair:

EXPENSE CODE	DESCRIPTION	AMOUNT
502	Short-term Rental Expense	\$180 (Max)
Contact the Warranty claims call center 1-800-933-3712 Option 7, if additional expense is required.		

**NOTE:** If you already have clients in **long-term** rentals, claim the rental using the OP code below and do not file a rental claim under R1622 or R1704. Each Op code can only be claimed once per VIN, so do not submit a claim until the rental is no longer needed or 30 days has elapsed, whichever occurs first.

**Retailer should not resubmit rental bills that have been reimbursed when the vehicle is remedied.**

OP CODE	EXPENSE CODE	LONG-TERM RENTAL DESCRIPTION:	REQUIRED/OPTIONAL:
P63250	502	\$60.00 @ 30 days (\$1,800 Max)	Optional for 1-30 days rental
P63260		\$60.00 @ 30 days (\$1,800 Max)	Optional for 31-60 days rental
P63270		\$60.00 @ 30 days (\$1,800 Max)	Optional for 61-90 days rental

4. Once repaired, retailers should submit the claim, using the claims coding provided, and release the vehicle.

\*\*\*\*\* Release Schedule \*\*\*\*\*

<p><b>Parts</b></p>	<ul style="list-style-type: none"> <li>• Retailers will need to order an inflator part and a wiring harness for each vehicle except for 2006-08 FX, which uses a passenger airbag module assembly.</li> <li>• Some parts are currently restricted and can be ordered on DCS using an SVC order type. Refer to IPSB/16-384 for DCS SVC ordering instructions. Non-restricted parts can be ordered through the normal process.             <ul style="list-style-type: none"> <li>○ Inflaters:                 <ul style="list-style-type: none"> <li>▪ 2003-05 FX, 2003-04 I35, and 2006-07 M: K8561-7999B</li> <li>▪ 2008-10 M: 98561-7999E (not restricted)</li> </ul> </li> <li>○ Harnesses:                 <ul style="list-style-type: none"> <li>▪ 2003-04 I35: B4167-2Y00A</li> <li>▪ 2003-05 FX: B4A67-CG00A</li> <li>▪ 2006-07 M: B4A67-EH50C</li> <li>▪ 2008-10 M: B4A67-EH50D (not restricted)</li> </ul> </li> <li>○ Modules:                 <ul style="list-style-type: none"> <li>▪ 2006-08 FX: K8515-CL71A (not restricted)</li> </ul> </li> </ul> </li> </ul>
<p><b>Special Tools</b></p>	<ul style="list-style-type: none"> <li>• J-52352 USB Bar Code Scanner is required             <ul style="list-style-type: none"> <li>○ This required tool was shipped, at no cost to retailers, the week of December 7, 2016</li> </ul> </li> <li>• J-51315-KIT Airbag module support</li> <li>• Order additional tools as necessary from TechMate @ 1-800-662-2001</li> </ul>
<p><b>Repair</b></p>	<ul style="list-style-type: none"> <li>• ITB16-049 - 2008-2010 M(Y50)</li> <li>• ITB16-050 - 2006-2008 FX35/45 (S50)</li> <li>• ITB17-003 - 2003-2004 I35 (CA33), 2003-2005 FX35/45 (S50), and 2006-2007 M35/45 (Y50)</li> <li>• R1704 procedure included with this announcement after FAQ for: 2003-2004 I35 (CA33), 2003-2008 FX35/45 (S50), and 2006-2010 M35/45 (Y50)</li> </ul>
<p><b>Owner Notification</b></p>	<p>Infiniti began notifying owners of all potentially affected 2008-10 M35/45 vehicles in <b>December, 2016</b> via U.S. Mail. Infiniti will notify owners of potentially affected 2003-08 FX, 2003-04 I35, and 2006-07 M35/45 owners in <b>February and March, 2017</b> via U.S. Mail.</p>

\*\*\*\*\* Retailer Responsibility \*\*\*\*\*

It is the retailer's responsibility to check Service Comm using the appropriate Campaign I.D. for the campaign status on each vehicle falling within the range of this voluntary safety recall campaign which for any reason enters the service department. This includes vehicles purchased from private parties or presented by transient (tourist) owners and vehicles in retailer inventory. If a VIN subject to this recall campaign was part of a retailer trade, the letter associated with that VIN should be forwarded to the appropriate retailer for service completion.

## Frequently Asked Questions (FAQ):

**Q: Is this a safety recall campaign?**

A. Yes.

**Q: How do I know if my vehicle has a problem with the front passenger airbag inflator?**

A. If your vehicle is subject to this campaign you will receive an Owner Notification letter from Infiniti. If you'd like, I can check your vehicle identification number (VIN) right now to see if your vehicle is affected by a different recall.

**Q: What is the problem?**

A. Takata has determined that a defect related to motor vehicle safety may arise in some of the subject ammonium nitrate inflators due to propellant degradation occurring after prolonged exposure to high absolute humidity, high temperatures and high temperature cycling. Activation of a non-desiccated ammonium nitrate inflator with degraded propellant may result in an inflator rupture. An inflator rupture may cause metal fragments to pass through the air bag and into the vehicle interior at high speed, which may result in injury or death to vehicle occupants.

**Q: Have all affected owners already been notified?**

A. Clients affected by this expansion were sent interim notification letters in **July, 2016**. Infiniti began sending invitation to repair letters to owners of all potentially affected 2008-10 M35/45 vehicles in **December, 2016** via U.S. Mail. Infiniti will send invitation to repair letters to owners of potentially affected 2003-08 FX, 2003-04 I35, and 2006-07 M35/45 owners in **February and March, 2017** via U.S. Mail.

**Q: I have not received a letter but want to make sure my vehicle is not affected.**

A. Please give me your vehicle identification number (VIN) so that I can check if your vehicle is included in this recall.

**Q: Is it safe to drive my vehicle?**

A. Infiniti strongly recommends that if your vehicle is confirmed to be affected, you have this safety recall repair performed as soon as possible. Please contact your retailer once you receive an invitation to repair letter to schedule an appointment. **In the meantime, do not allow passengers to ride in the front passenger seat unless the interim repair (R1618/R1619) was performed.**

**Q. Is there anything owners can do to avoid the risk/danger?**

A. If you received a safety recall notice about the passenger front airbag, **do not allow passengers to ride in the passenger seat unless the interim repair (R1618/R1619) was performed.**

**Q. Does my vehicle have Takata Airbag inflators?**

A. Many vehicles are equipped with Takata Airbag inflators. However, only certain specific ones are affected by these recalls. **Let me check your VIN to confirm whether your vehicle is affected – if affected, it needs to be remedied as soon as parts become available.** If your vehicle is not affected, no further action is needed.

**Q. Will alternate transportation be provided while the retailer is servicing the vehicle?**

A. Infiniti may provide a courtesy vehicle for the client to use while their vehicle is being serviced. Courtesy vehicles are subject to availability and not guaranteed. Please check with your retailer for availability and further details.

Rental is available while parts are on order:

EXPENSE CODE	DESCRIPTION	AMOUNT
502	Rental Expense	\$180 (Max)
Contact the Warranty claims call center 1-800-933-3712 Option 7, if additional expense is required.		

**Q. Are parts available for the recall repair?**

A. Yes, the final remedy is now available for vehicles subject to campaign I.D. R1622 and R1704.

**Q. Will I have to take my vehicle back to the selling retailer to have the service performed?**

A. No, any authorized Infiniti retailer can repair Infiniti vehicles.

**Q. How long will the corrective action take?**

A. This free service should take about two to three (2-3) hours to complete, but your Infiniti retailer may require your vehicle for a longer period of time based upon their work schedule.

**Q. All these vehicles are receiving a passenger airbag inflator or module replacement. Why are there so many campaign IDs and bulletins?**

A. The Takata recalls are very complex. Vehicles in each campaign are separated by various zones for the same make and model year. Infiniti must track each group of vehicles using specific campaign IDs to ensure the repair was completed correctly. Additionally, interim and final repairs must also be tracked, including which vehicles received both interim and final repairs.

There may be some minor differences from one campaign to another, so it is **very important for retailers to follow the instructions in each campaign bulletin and the assigned campaign ID for each VIN**. Retailers should not deviate from published repair directions and assume that a part referenced for one group of vehicles for a campaign population will work for another.

**Q. Why do some vehicles of the same model and model year have parts available in one campaign ID and not available in another?**

A. As noted above, the Takata campaign is very complex. Repairs and owner notifications are being managed by NHTSA and an independent monitor for all OEMs. Infiniti has strict requirements we must adhere to, including servicing for priority groups and recall completion deadlines under the coordinated remedy program, which is approved by NHTSA.

**Q. I have other concerns, who do I talk to?**

A. Please contact Consumer Affairs at the numbers below.

Region	Division	Number
United States	Infiniti North America	1-800-662-6200

**Q. The media has contacted me with questions about Infiniti's recall campaigns. What should I do?**

A. Please direct all media inquiries to Infiniti Corporate Communications.  
Media Contacts:  
Office: 615-725-1000

## **R1704 Repair Instructions Follow**

- Pages 7 -12 are scan tool procedures that apply to the first 3 repairs
- 2003-2004 I35 – repair begins on page 14
- 2003-2005 FX35/45 repair begins on page 24
- 2006-2007 M35/45 repair begins on page 33
- 2006-2008 FX35/45 repair begins on page 45
- 2008-2010 M35/45 repair begins on page 53

# 2003-2004 I35, 2006-2007 M AND 2003-2005 FX35/45 FRONT PASSENGER AIR BAG INFLATOR

## REQUIRED SPECIAL TOOLS

Air Bag Module Support (J-51315-KIT)

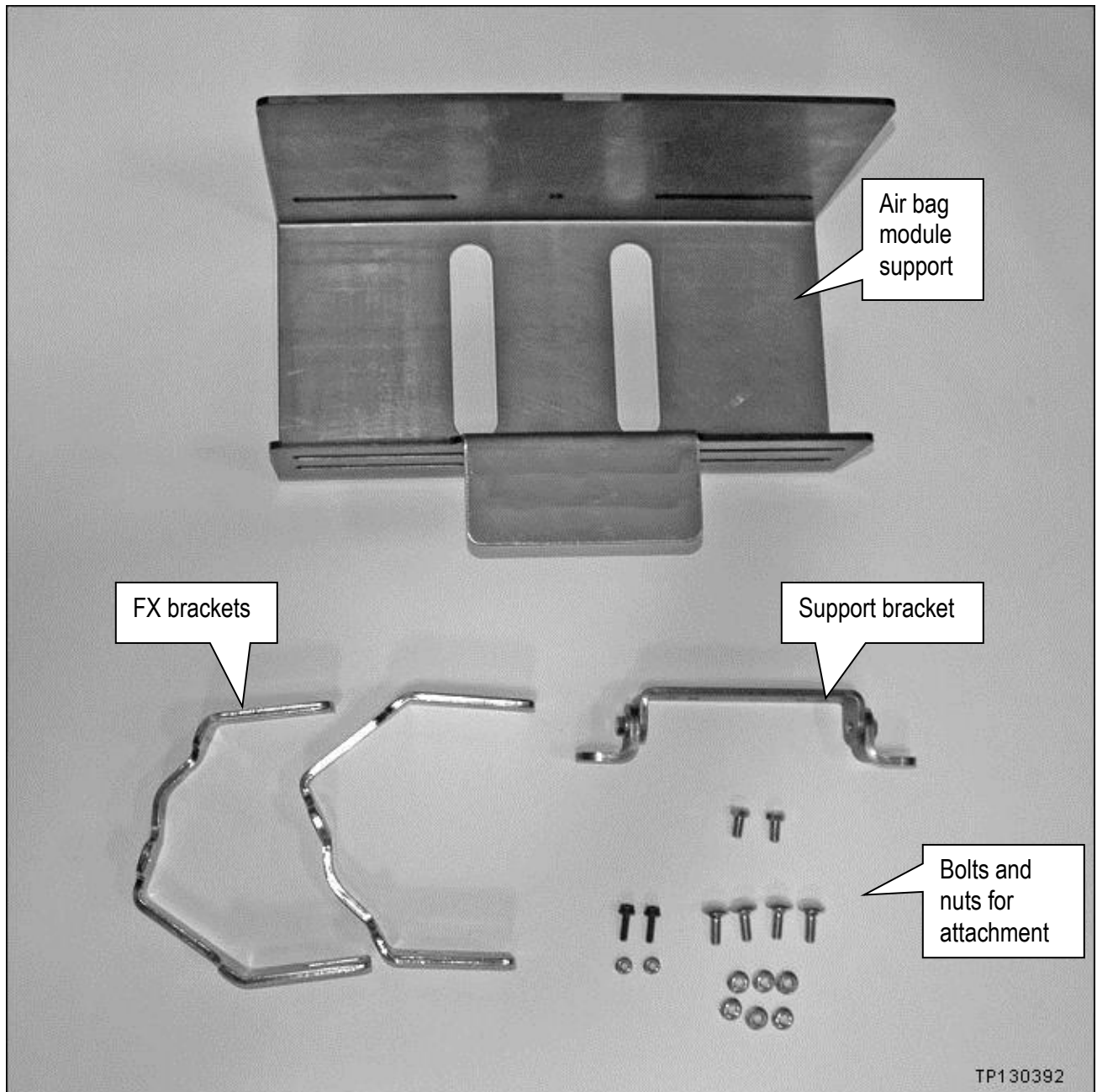

Figure A



### Quick Scan Tool (J-52352)

- Each retailer has been shipped one Quick Scan Tool (J-52352).
- Additional tools can be obtained from Tech•Mate at 1-800-662-2001.



Figure B



## SERVICE PROCEDURE

1. Write down the radio settings.

Presets	1	2	3	4	5	6
AM						
FM 1						
FM 2						
SAT 1						
SAT 2						
Bass	Treble		Balance		Fade	Speed Sen. Vol.

2. Turn the ignition OFF.
3. Disconnect both battery cables, negative cable first.
4. Wait at least 3 minutes.
5. Register the new inflator serial number as follows.
  - The new inflator is listed in the Parts Information.

- a. Attach the quick scan tool (J-52352) to your CONSULT PC USB port.

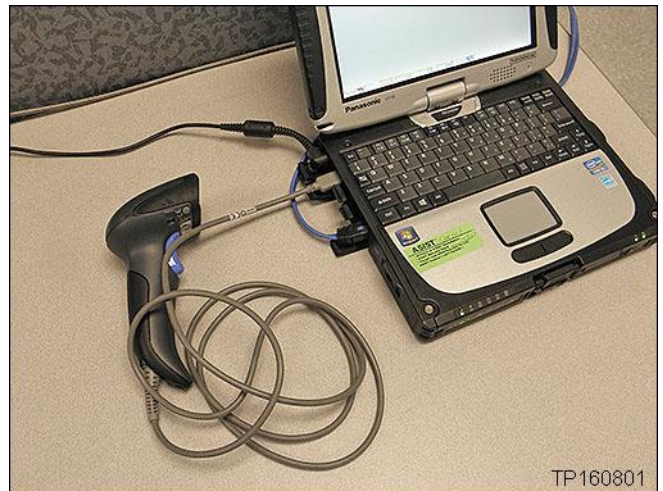

Figure 1

b. On the left side of the ASIST main menu, select **Tech Support Info**, then **Inventory Vehicle Actions**.

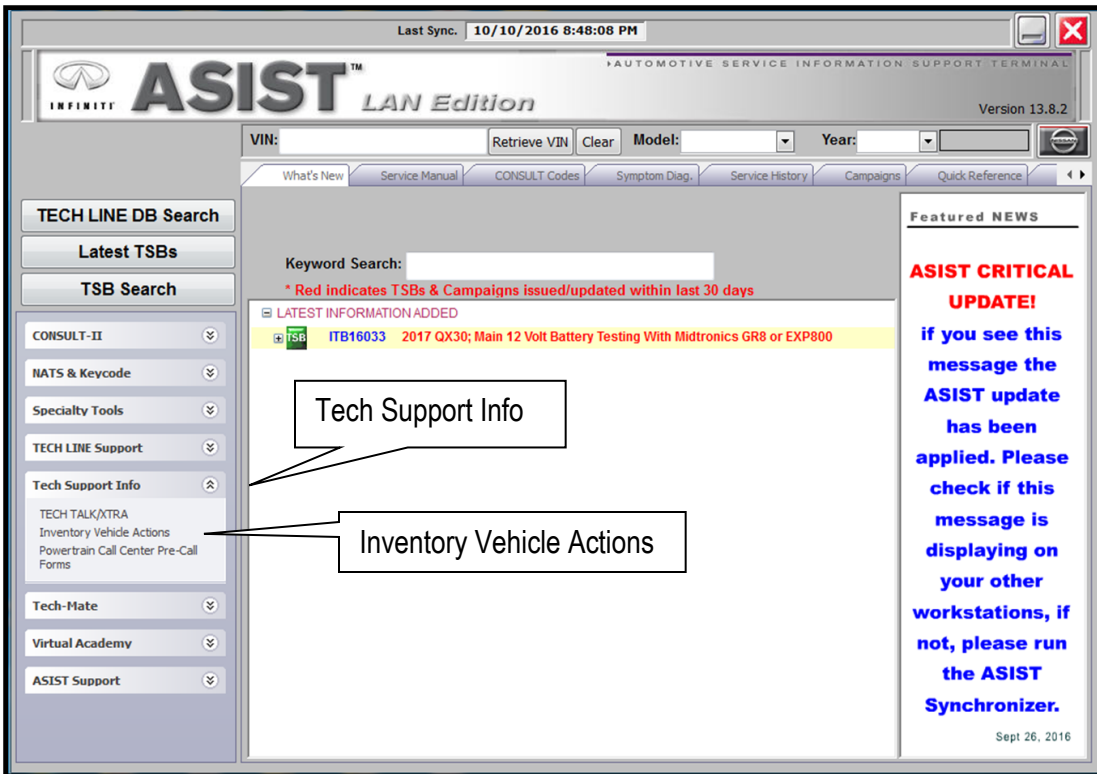

Figure 2

c. Select **CLICK HERE** (Air Bag to VIN Registration).



Figure 3

d. Use the quick scan tool to scan the bar code (VIN) on the B-pillar label.

- Wipe any dirt/debris from bar code before scanning.

**NOTE:**

- Some labels may not scan quickly.
- Hold the scan tool approximately 6 inches away from the label.
- Hold the trigger down until the label is read (this may take several seconds).



Figure 4

- VIN will automatically populate (see Figure 5).
- If needed, VIN can be entered manually.

**Airbag to VIN Registration**

11/28/2016 1:36:32 PM

**Please enter/scan the VIN and Airbag Inflator Serial Number**

**Dealer Code**      ■ ■ ■ ■

**Key Number**      ■ ■ ■

**VIN**     

**Airbag Serial Number**            **Submit**

Step f; see next page.  
(Select submit after both fields are populated).

Figure 5

- e. Use the quick scan tool to scan the bar code (serial number) on the new inflator shipping box.
- The serial number will automatically populate (see Figure 5 on previous page).

**NOTE:** If needed, the serial number can be entered manually.

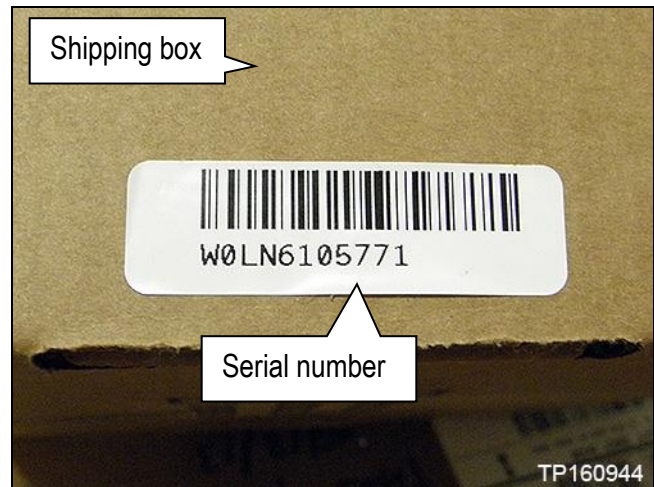

Figure 6

- f. Select **Submit** on the ASIST screen (see Figure 5 on the previous page).
6. Remove the passenger air bag module (module) from the vehicle.
- Refer to the appropriate Electronic Service Manual (ESM) for module removal information.

**IMPORTANT:** Follow all cautions, warnings, and notes in the Electronic Service Manual (ESM) when working on or near a Supplemental Restraint System (SRS), such as an air bag.

**CAUTION:** Handle interior trim carefully to avoid damage. Work with clean hands and clean tools to avoid dirt and stains. Use protective covers as needed.

7. Set the module in a clean working area.
- NOTE:** Do not set the module with cover facing down.
8. Securely mount the air bag module support (support) in a vice (see Figure 7).

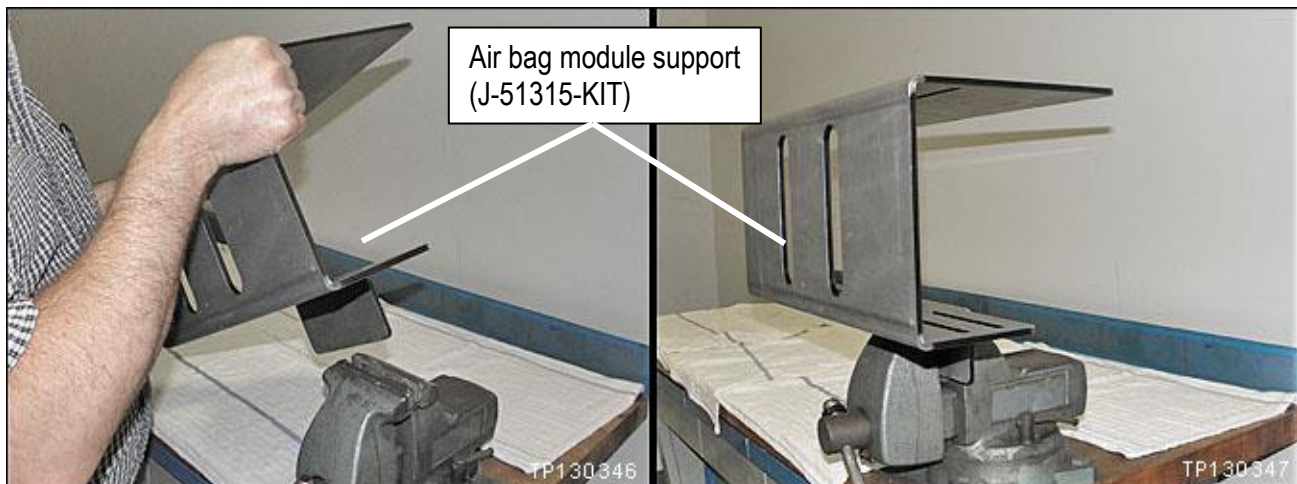

Figure 7

**WARNING:** Work from behind and to the sides of the support.

## Remove the Inflator from the Air Bag Module Assembly

### 9. Replace the module Inflator:

- I35; page 9
- FX; page 19 **IMPORTANT: Connection of the new harness for the M is different than the I35 or FX. Make sure to read the harness connection instructions for each vehicle**
- M; Page 28.

### 10. Reinstall the module into the vehicle in reverse order of removal.

- Make sure to use the new “one time use” module mounting bolts included with the new inflator.

**NOTE:** For FX (per a Service Manual amendment – ITB13-023) only one air bag mounting bolt is “one time use”. This “one time use” bolt is included in the box with the FX inflator.

### 11. Re-connect both battery cables – positive cable first.

### 12. Reset the clock and the radio settings.

### 13. Turn the ignition ON and observe the air bag warning light:

- Light should illuminate for 7 seconds and then go out.

**NOTE:** If the Air Bag Warning light does not operate as described above there may be an issue not covered by this campaign. Refer to ASIST and the appropriate Service Manual for additional diagnostic and repair information.

### 14. Return the removed (old / non-deployed) inflator in the box that the new inflator arrived in.

- Follow the return instructions provided by Takata.
- Return instructions provided by Takata are attached to this bulletin on page 39

## 135 Inflator replacement

**WARNING:** Wear safety glasses while performing inflator replacement.

1. Set the module on a clean working area.
2. Disconnect the harness clip from the module frame.

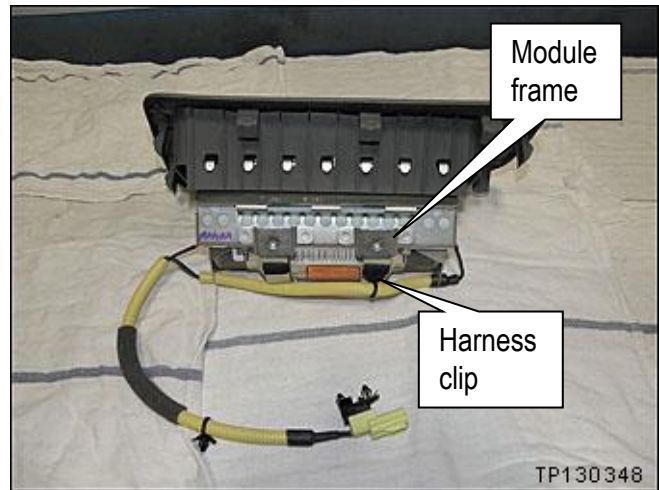

Figure M1

3. Attach the module support bracket to the module frame.
  - Tighten the bolts holding the bracket to the module frame.
  - Leave the L brackets on each end slightly loose to allow for positioning of the module in the support.

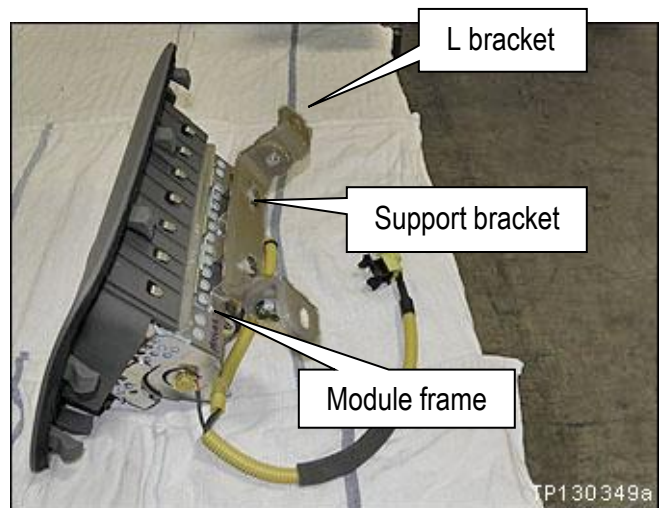

Figure M2



**WARNING:** Work from behind and to the sides of the support.

4. Mount the module in the support.

- Use bolts and nuts supplied with the support.

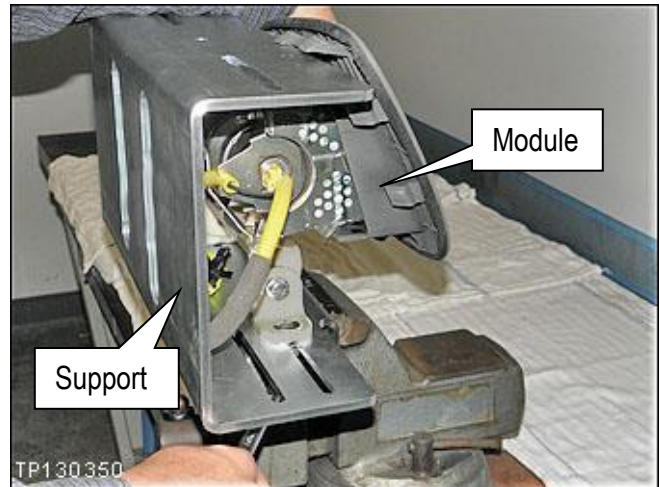

Figure M3

5. Make sure the module is centered in the support.

**NOTE:** Centering the module in the support will allow access to the inflator securing nuts through the slots in the support.

6. Tighten all of the mounting bolts and nuts that hold the module to the support.

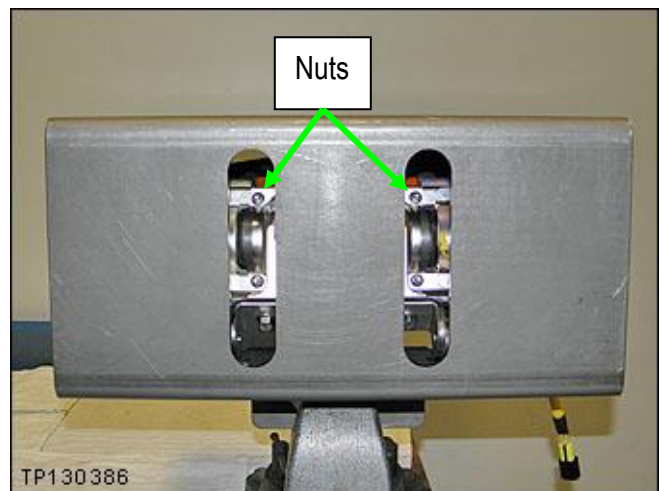

Figure M4

7. Carefully cut a few inches of the yellow corrugated harness cover in the area shown.

- **Do not** cut the wires inside the corrugated cover.

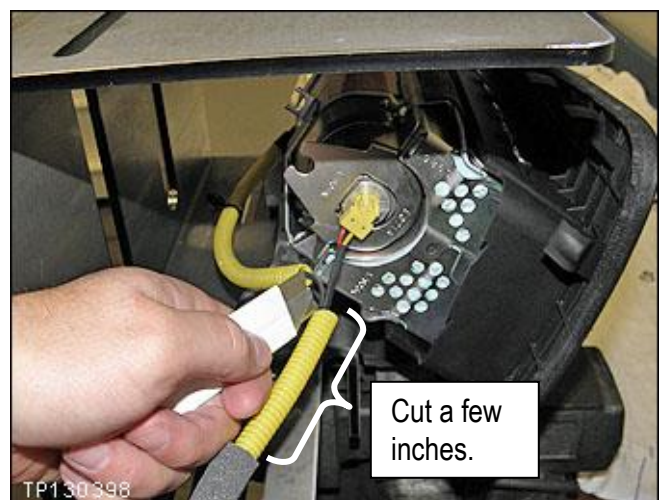

Figure M5



8. Attach 2 shorting pins to the inflator harness as shown.

- Make sure to pair the wires from each end of the inflator.

**Blue with White**

**Red with Yellow**

- Use an insulation displacement type wire connector as a shorting pin.
- Refer to the Parts Information for additional connector/shorting pin information.

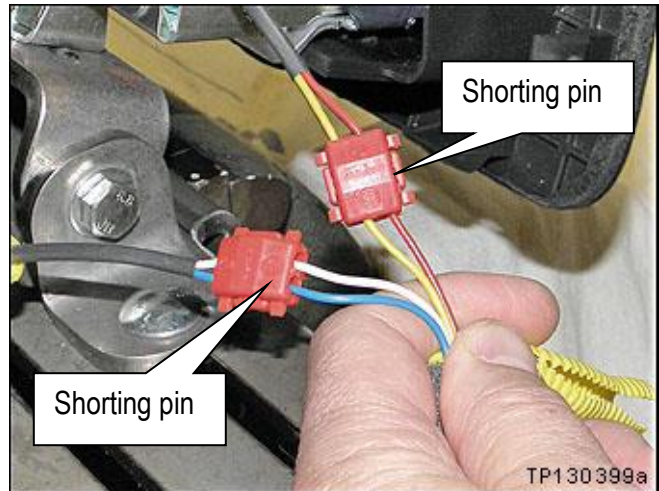

Figure M6

9. Cut off the connector end of the harness.



Figure M7

10. Remove the 4 nuts from the module that hold the inflator in place (see Figures M8 and M9).

- Use a ratchet and extension.



Figure M8

- Remove the 4 nuts.

**NOTE:** These nuts will not be reused.

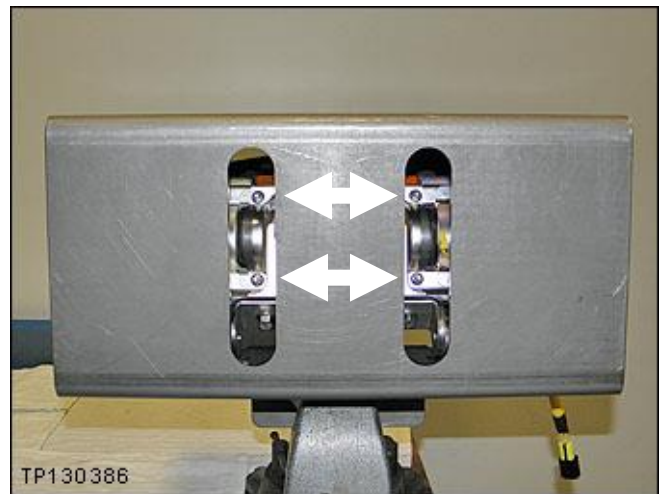

Figure M9

11. Remove the inflator stopper.

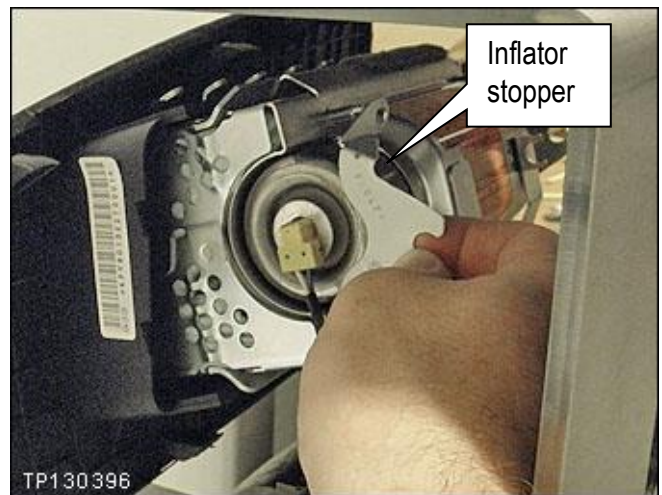

Figure M10

12. Push the right side of the inflator out of the module.

- Twist the inflator to a position that will allow the connector and harness to fit through the opening.

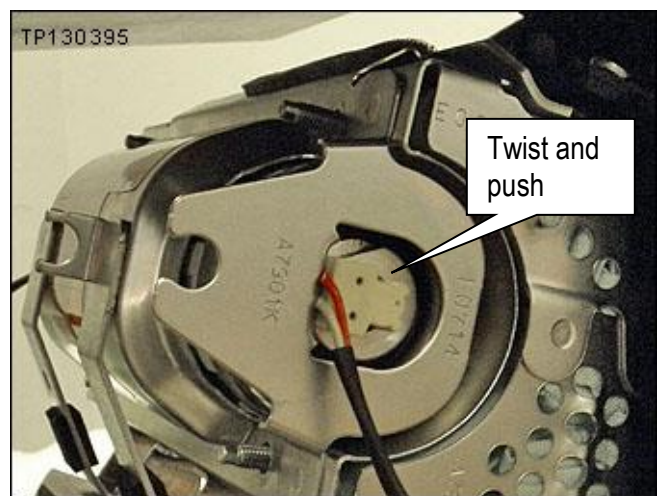

Figure M11

13. Pull the inflator completely out of the module from the left side.

14. Set the old inflator in the clean working area and make sure it does not roll and fall to the floor.

**NOTE:**

- Follow the return instructions provided by Takata, which are included in the box with the new inflator.
- Takata supplied return instructions are also attached to this bulletin on page 39.



Figure M12

15. Remove the new inflator from the box.

16. Slide the new inflator into the module from the left side.

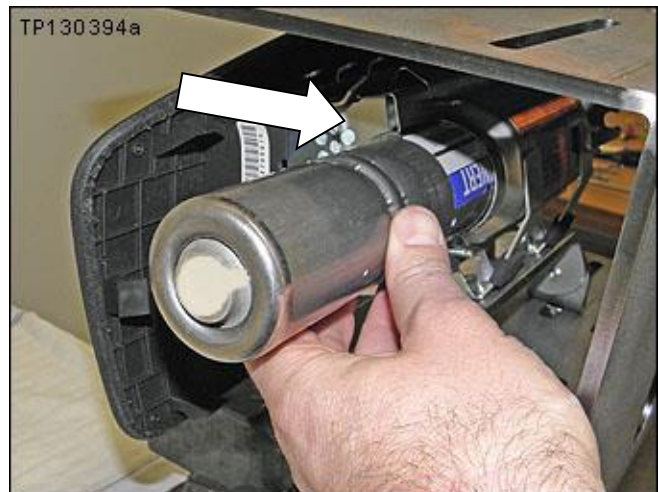

Figure M13

17. Make sure the inflator is positioned / oriented correctly as shown.

- **The flat side of the inflator end (on the right side) must align with the flat side of the inflator housing.**

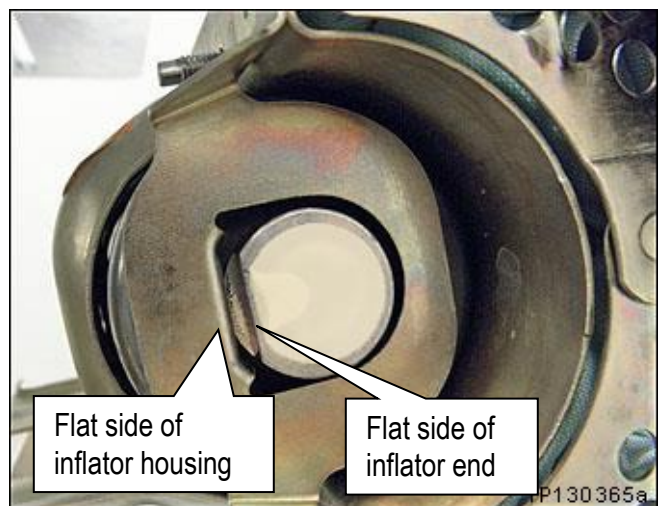

Figure M14



18. Install the inflator stopper and 4 inflator securing nuts finger tight (see Figure M15).

- Make sure to **use new nuts**.
- New nuts are included with the new inflator.

19. Make sure the inflator is pushed all the way into its housing – no gap on the right side (see Figure M15).

20. Make sure there is no gap between the inflator stopper and the inflator on the left side (see Figure M15).

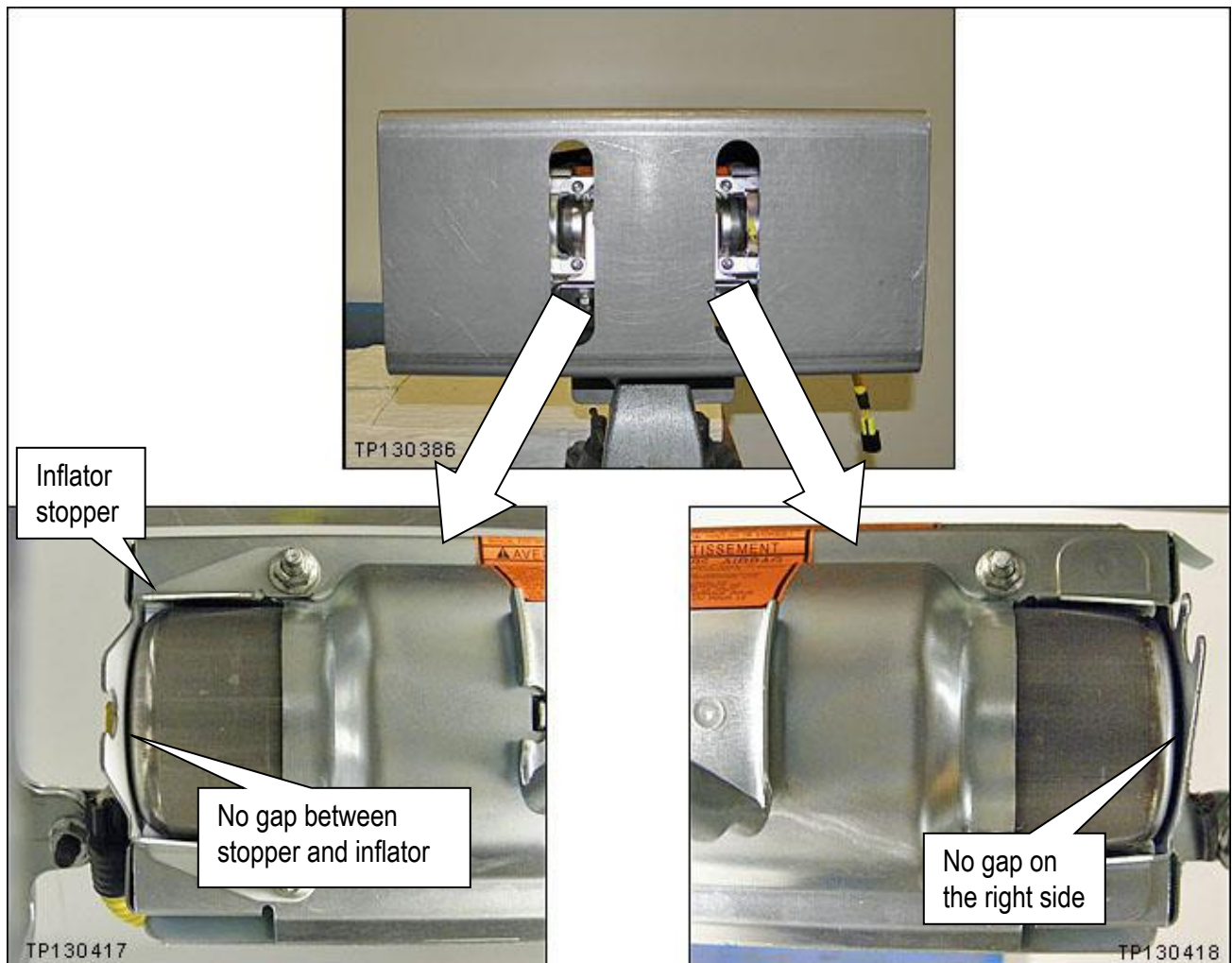

Figure M15

21. Torque the 4 inflator securing nuts.

- Torque nuts to:  
3.9 N•m (0.39 kg-m, **34 in-lb.**)
- Torque in the order shown.

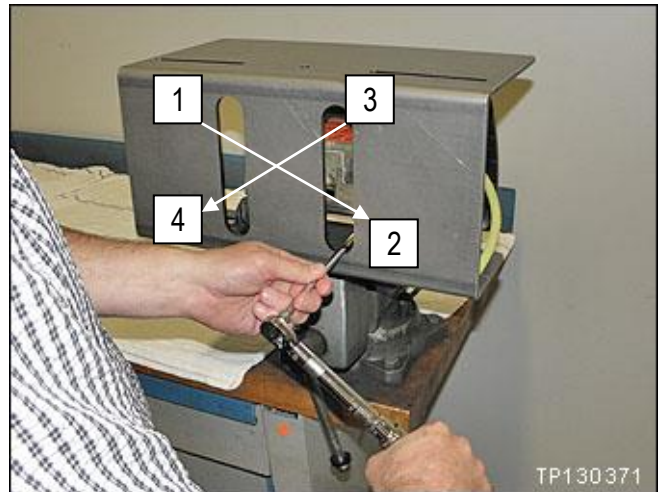
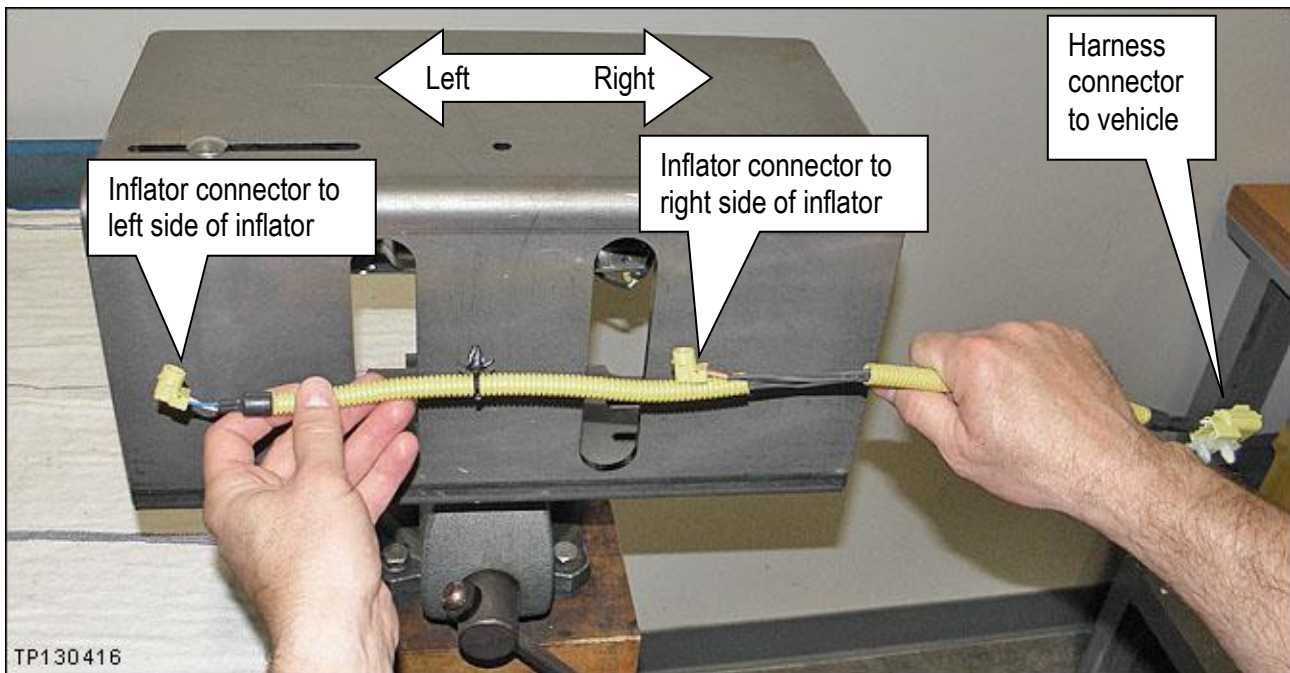

Figure M16

**IMPORTANT:**

- In the next step you will be attaching the new harness to the new inflator.
- Once the inflator connector is attached to the inflator, it cannot be disconnected.
- **Make sure to attach the connectors to the correct ends of the inflator (see M17).**
  - Left / Right orientation is as shown in Figure M17.



M17

22. Attach the new harness to each end of the inflator.

- Remove the dust proof stickers covering the ends of the inflator.
- A new harness is included with the new inflator.
- Make sure to attach the correct ends (see Figure M17 on the previous page).
- Refer to Figures M17, M18, M19, and M20.



Figure M18

- Make sure the T shape at the inflator end aligns with the T shape of the connector.

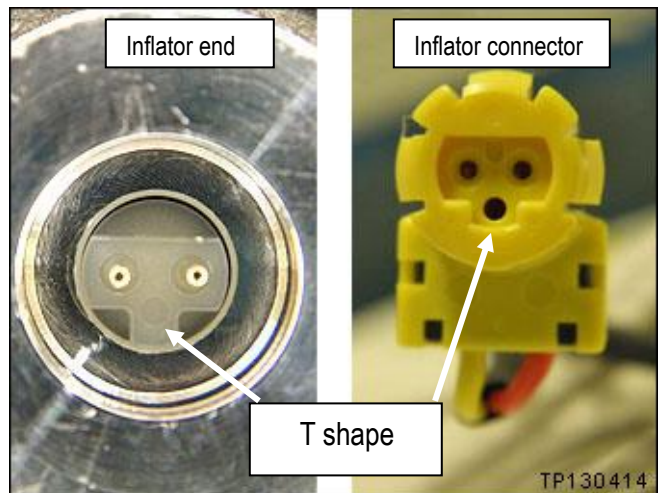

Figure M19

- Make sure the harness connector is fully engaged / seated (see Figure M20).

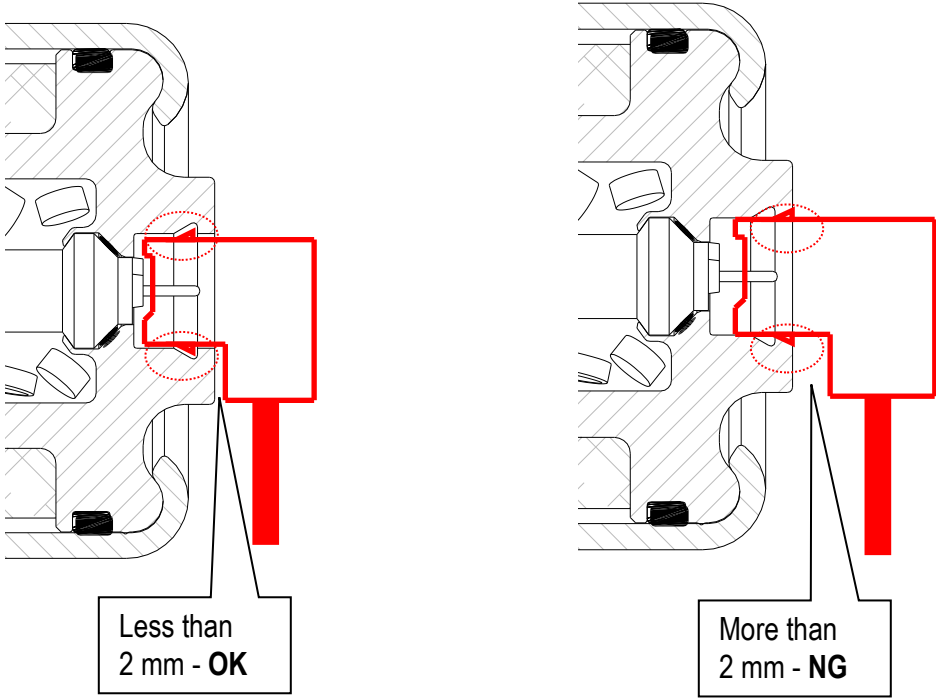

Figure M20

23. Remove the module from the support and set it on the clean working area.

24. Remove the support bracket from the module frame.

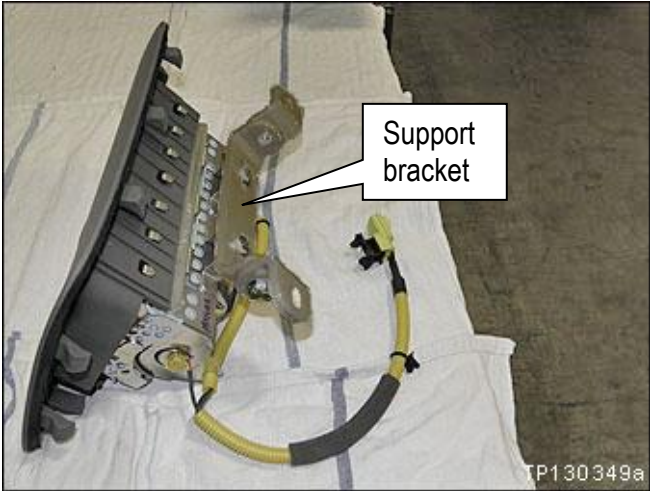

Figure M21



25. Attach the harness clip to the module frame.

26. Route/attach the harness to the harness guides.

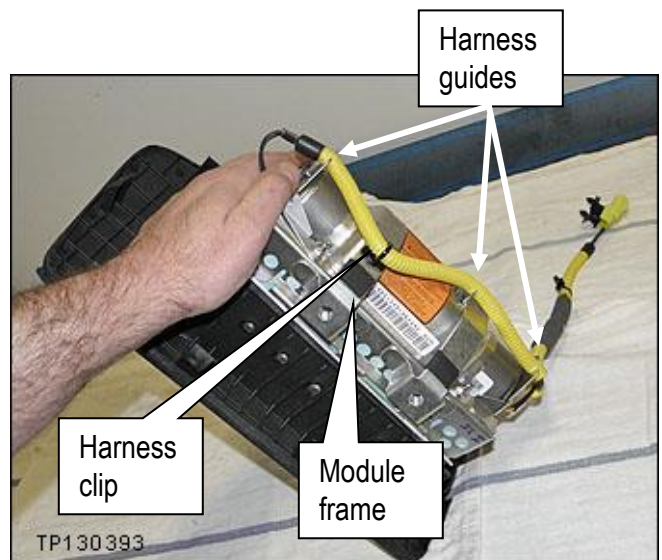

Figure M22

**NOTE:**

- **Make sure to return the removed (old / non-deployed) inflator in the box that the new inflator came in.**
- **Follow the return instructions provided by Takata.**
- **Return instructions provided by Takata are attached to this bulletin on page 39.**

## **FX** Inflator replacement

**WARNING:** Wear safety glasses while performing inflator replacement.

1. Set the module on a clean working area.
2. Disconnect the harness clip from the module frame.

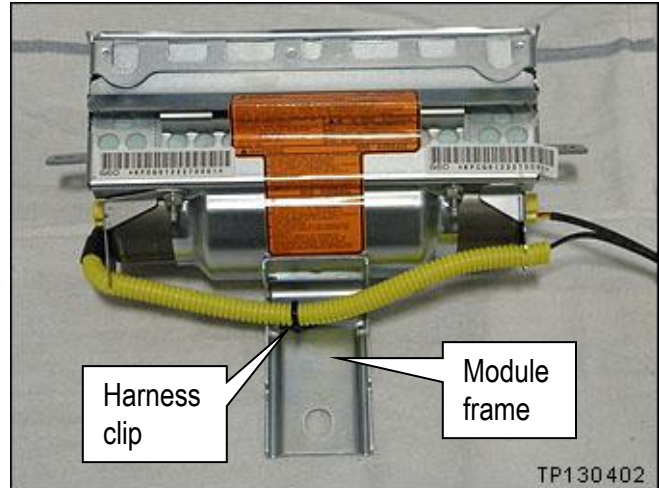

Figure F1

3. Attach the FX brackets to the support as shown.
  - Make sure the convex parts of the brackets are in the UP position.
  - Use bolts and nuts supplied with the support.
  - Leave the bolts/nuts slightly loose to allow for positioning of the module.

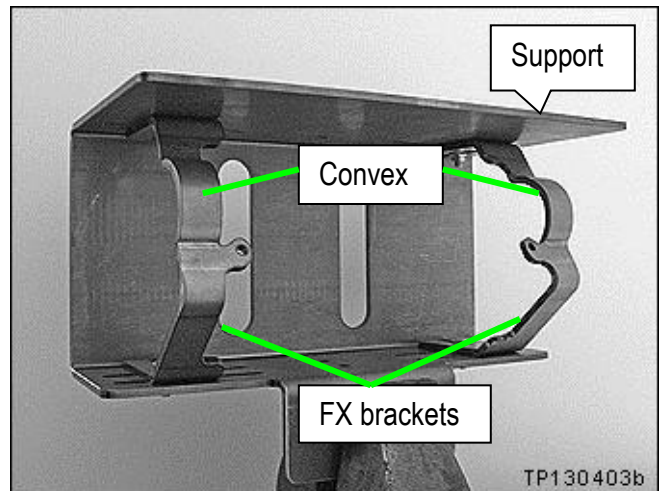

Figure F2

4. Attach the module to the FX brackets in the support as shown.
  - Use bolts and nuts supplied with the support.
  - Make sure the arrow on the bag is pointing up.

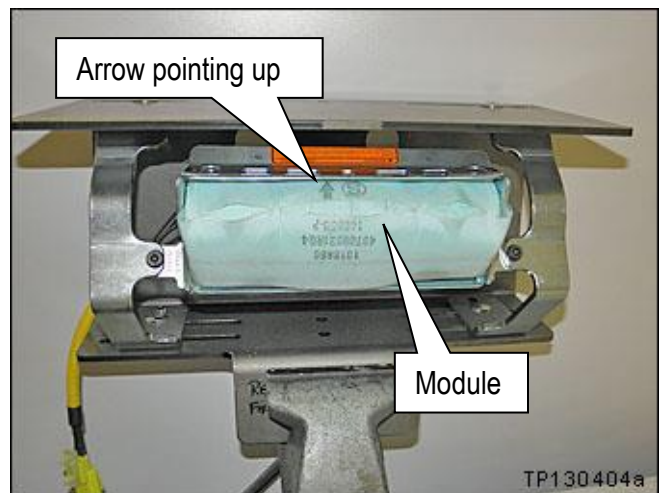

Figure F3

5. Make sure the module is centered in the support.

**NOTE:** Centering the module in the support will allow access to the inflator securing nuts through the slots in the support.

6. Tighten all of the mounting bolts and nuts that hold the module and brackets to the support.

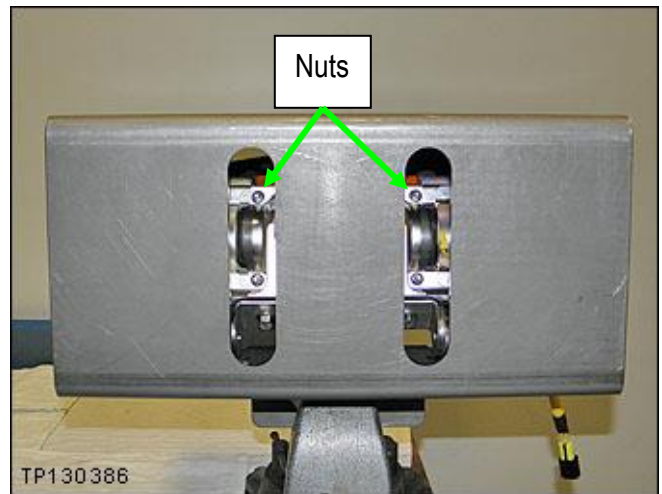

Figure F4

**WARNING:** Work from behind and to the sides of the support.

7. Carefully cut a few inches of the yellow corrugated harness cover in the area shown.

- **Do not** cut the wires inside the corrugated cover.

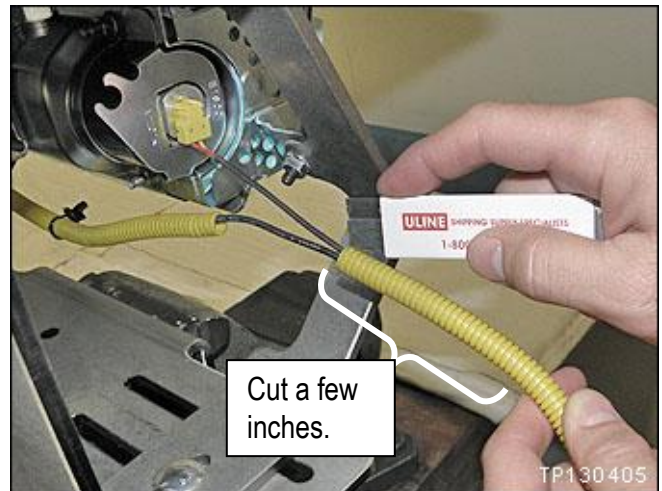

Figure F5

8. Attach 2 shorting pins to the inflator harness as shown.

- Make sure to pair the wires from each end of the inflator.

**Blue with White**

**Red with Yellow**

- Use an insulation displacement type wire connector as a shorting pin.
- Refer to the Parts Information for additional connector/shorting pin information.

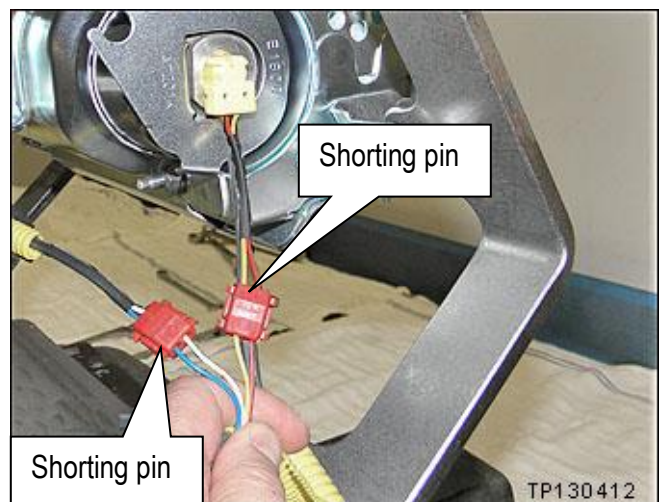

Figure F6

9. Cut off the connector end of the harness.



Figure F7

10. Remove the 4 nuts from the module that hold the inflator in place (see Figures F8 and F9).

- Use a ratchet and extension.

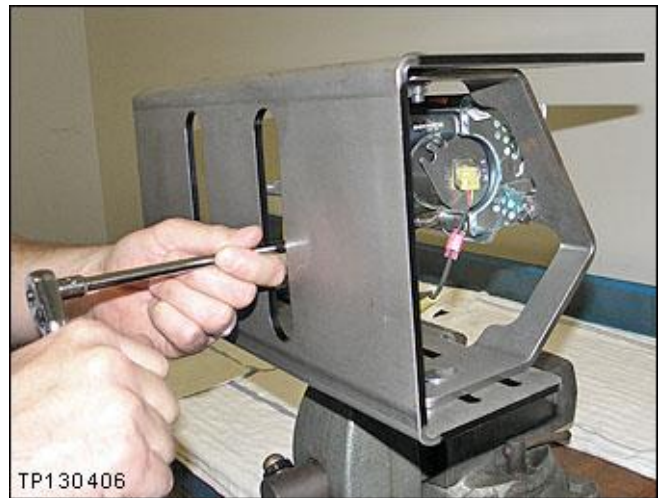

Figure F8

- Remove the 4 nuts.

**NOTE:** These nuts will not be reused.

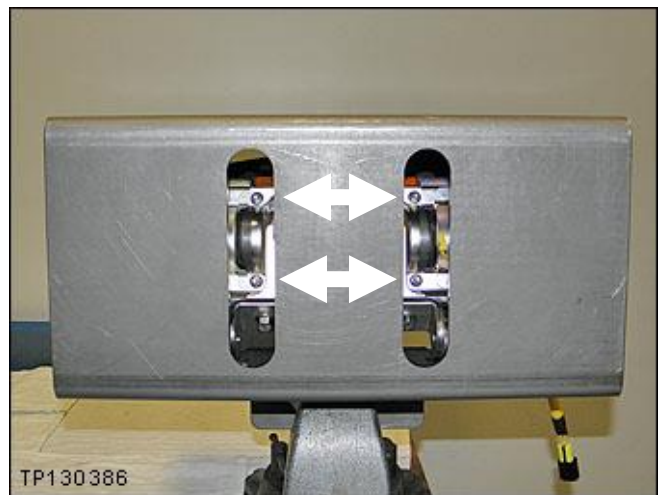

Figure F9



11. Remove the inflator stopper.

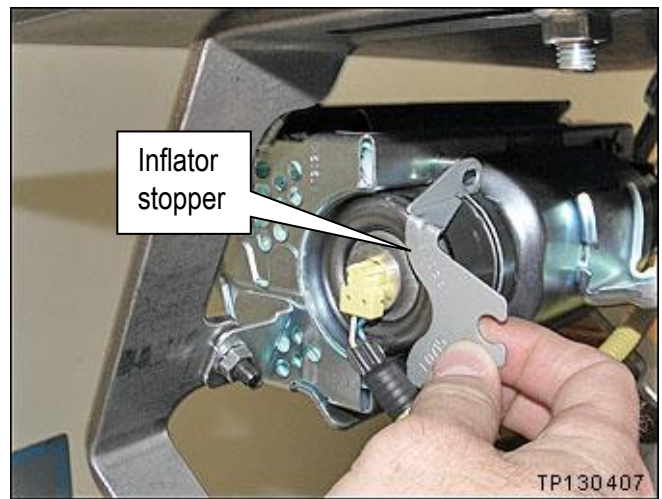

Figure F10

12. Push the right side of the inflator out of the module.

- Twist the inflator to a position that will allow the connector and harness to fit through the opening.

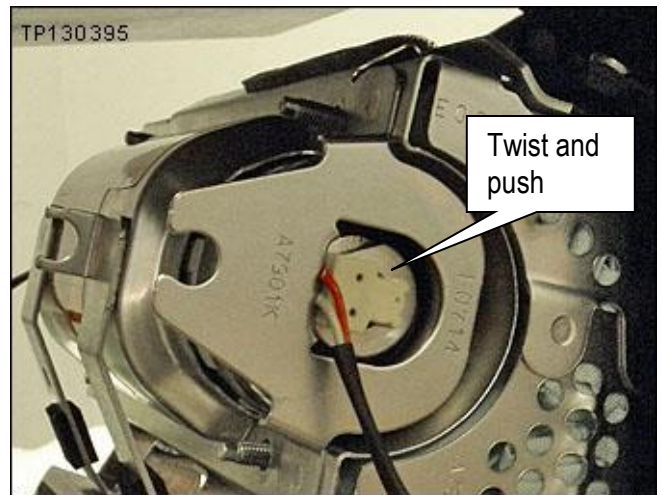

Figure F11

13. Pull the inflator completely out of the module from the left side.



Figure F12

14. Set the old inflator in the clean working area and make sure it does not roll and fall to the floor.

**NOTE:**

- Follow the return instructions provided by Takata.
- Return instructions provided by Takata are attached to this bulletin on page 39.

15. Remove the new inflator from the box.

16. Slide the new inflator into the module from the left side.



Figure F13

17. Make sure the inflator is positioned / oriented correctly as shown.

- **The flat side of the inflator end (on the right side) must align with the flat side of the inflator housing.**

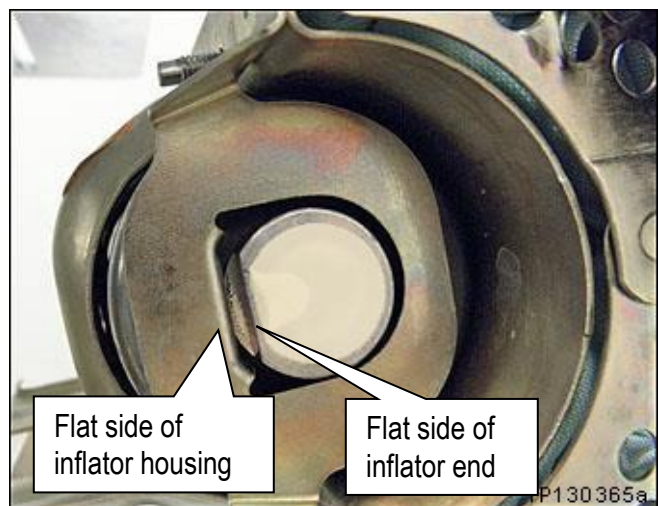

Figure F14

18. Install the inflator stopper and 4 inflator securing nuts finger tight (see Figure F15).

- Make sure to **use new nuts**.
- New nuts are included with the new inflator.

19. Make sure the inflator is pushed all the way into its housing – no gap on the right side (see Figure F15).

20. Make sure there is no gap between the inflator stopper and the inflator on the left side (see Figure F15).

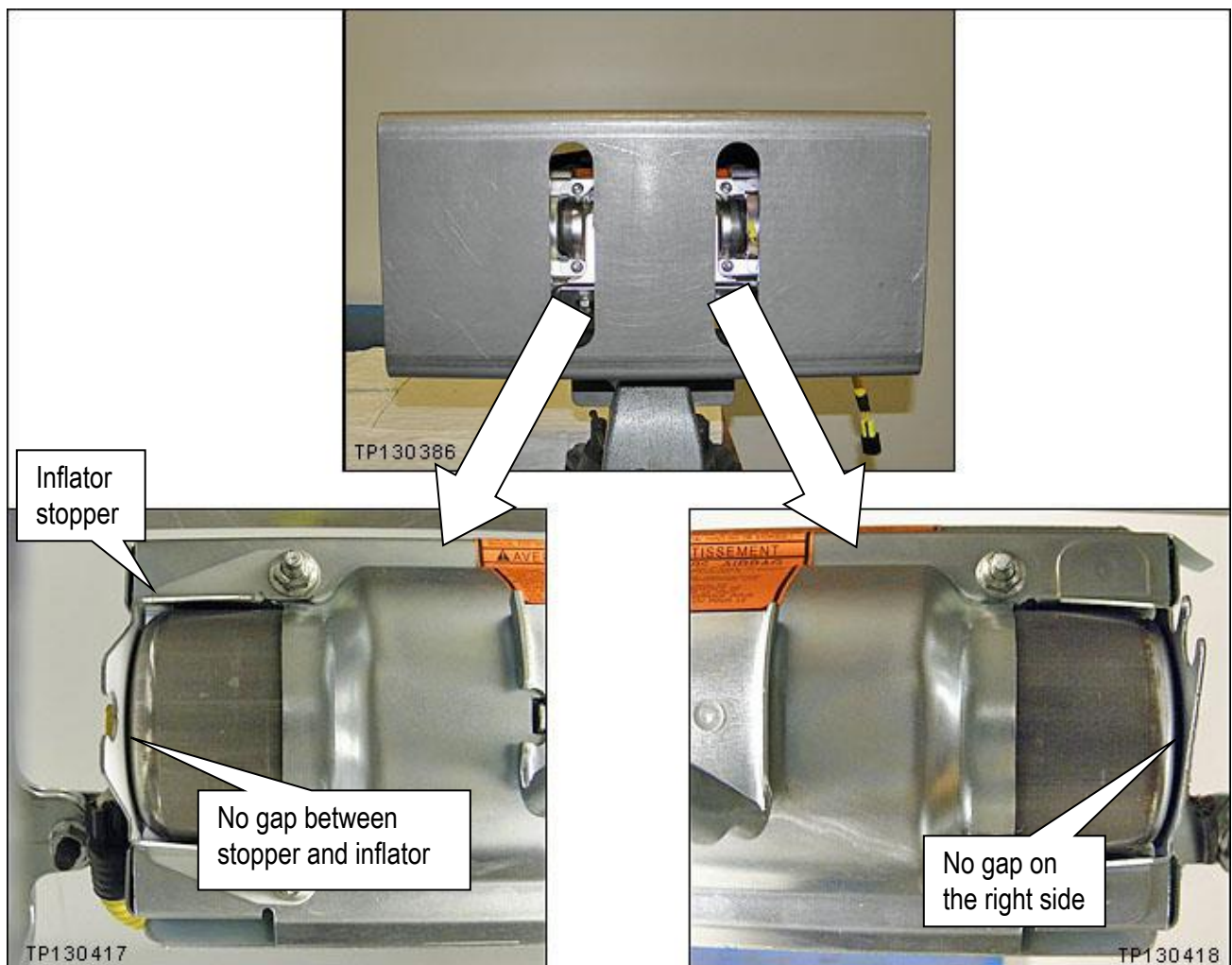

Figure F15



21. Torque the 4 inflator securing nuts.

- Torque nuts to:  
3.9 N•m (0.39 kg-m, **34 in-lb.**)
- **Torque in the order shown.**

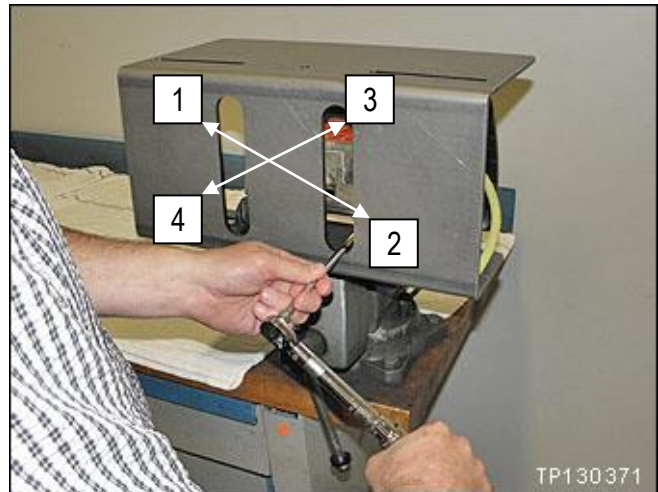

Figure F16

**IMPORTANT:**

- In the next step you will be attaching the new harness to the new inflator.
- Once the inflator connector is attached to the inflator, it cannot be disconnected.
- **Make sure to attach the connectors to the correct ends of the inflator (see F17).**
  - Left / Right orientation is as shown in Figure F17.

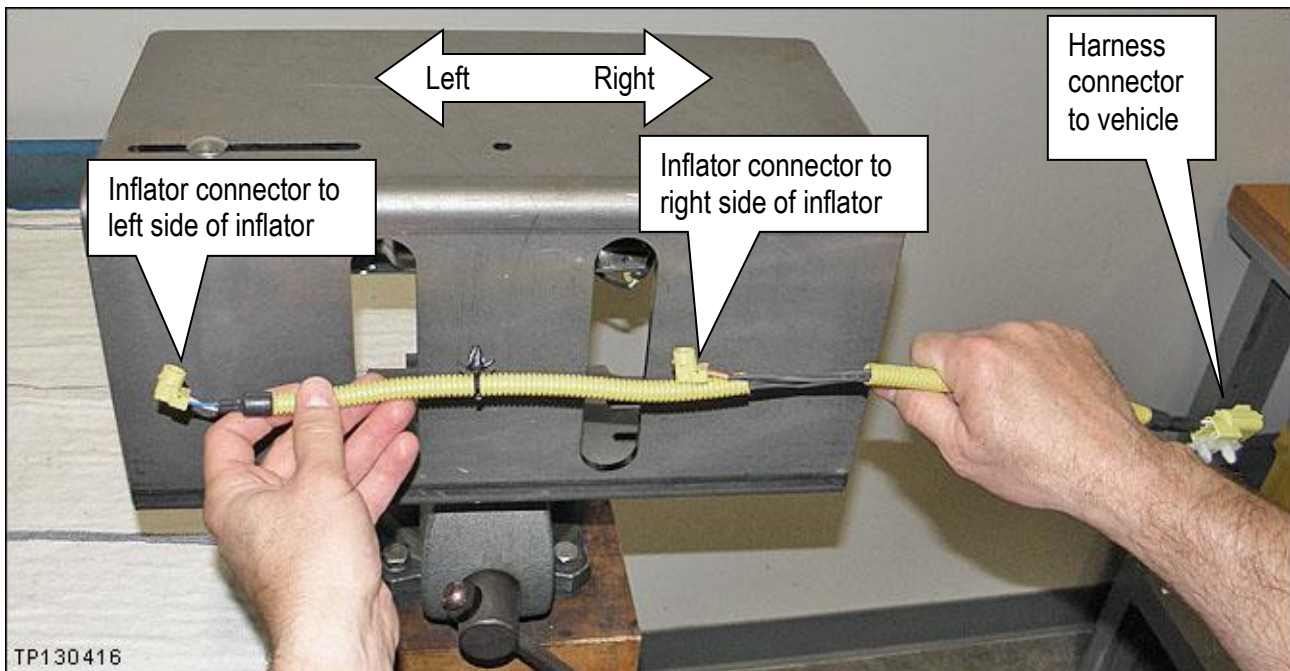

Figure F17

22. Attach the new harness to each end of the inflator.

- Remove the dust proof stickers covering the ends of the inflator.
- A new harness is included with the new inflator.
- Make sure to attach the correct ends (see Figure F17 on the previous page).
- Refer to Figures F17, F18, F19, and F20.

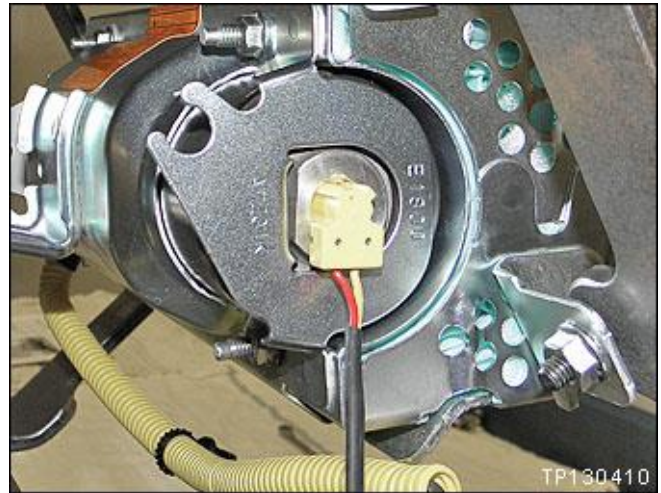

Figure F18

- Make sure the T shape at the inflator end aligns with the T shape of the connector.

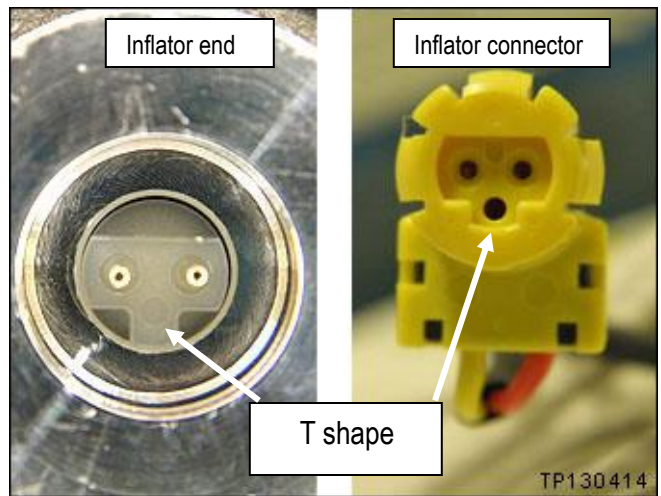

Figure F19

- Make sure harness connector is fully engaged / seated (see Figure F20).

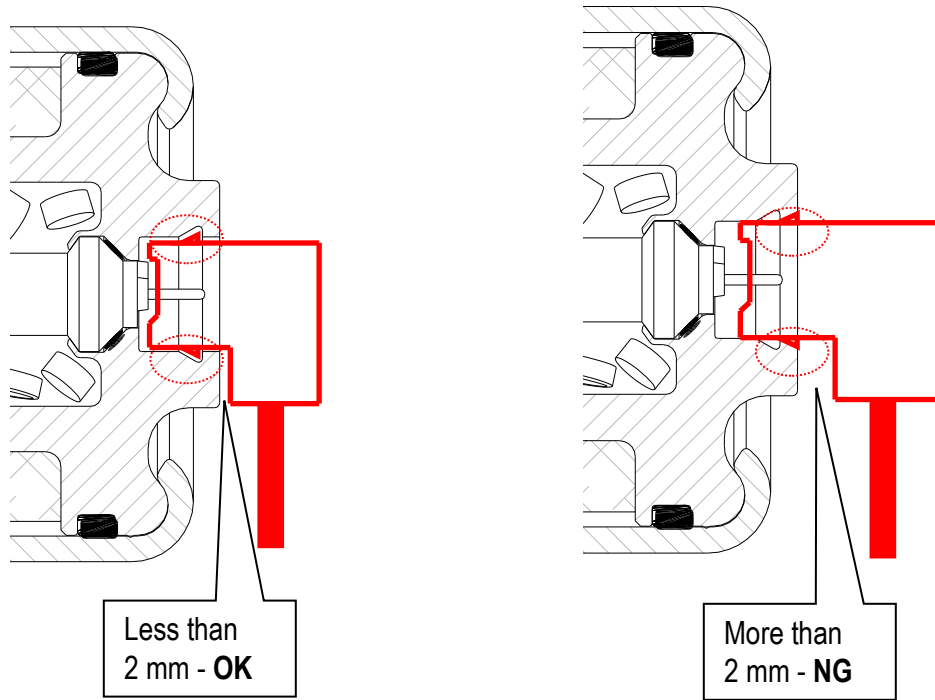

Figure F20

23. Remove the module from the support and set it on the clean working area.

24. Attach the harness clip to the module frame.

25. Clip the harness into the harness guides.

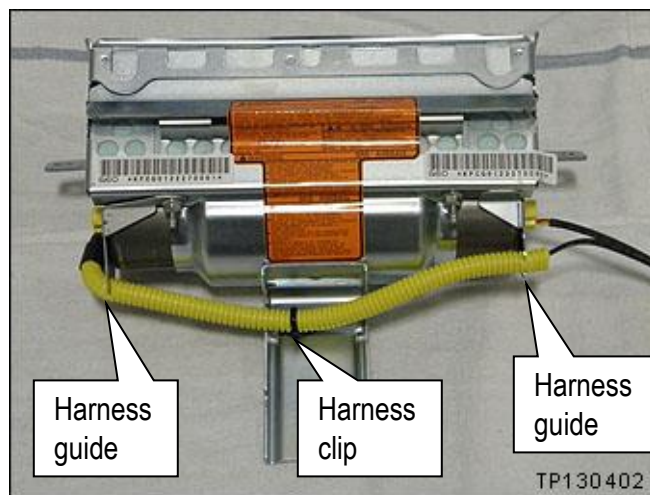

Figure F21

**NOTE:**

- Make sure to return the removed (old / non-deployed) inflator in the box that the new inflator came in.
- Follow the return instructions provided by Takata.
- Return instructions provided by Takata are attached to this bulletin on page 39.

## **M** Inflator replacement

**IMPORTANT:** Connection of the new harness for the M is different than the I35 or FX. Make sure to read the harness connection instructions.

**WARNING:** Wear safety glasses while performing inflator replacement.

1. Set the module on a clean working area.
2. Unclip the harness from the harness guides.

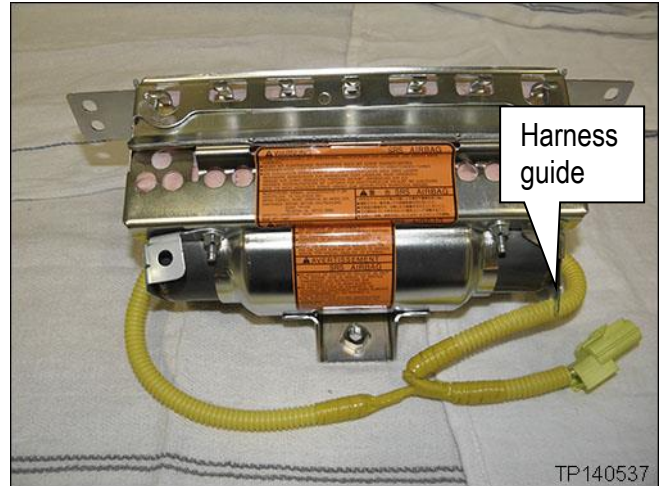

Figure Y1

3. Attach the FX brackets to the support as shown.
  - Make sure the convex parts of the brackets are in the UP position.
  - Use bolts and nuts supplied with the support.
  - Leave the bolts/nuts slightly loose to allow for positioning of the module.

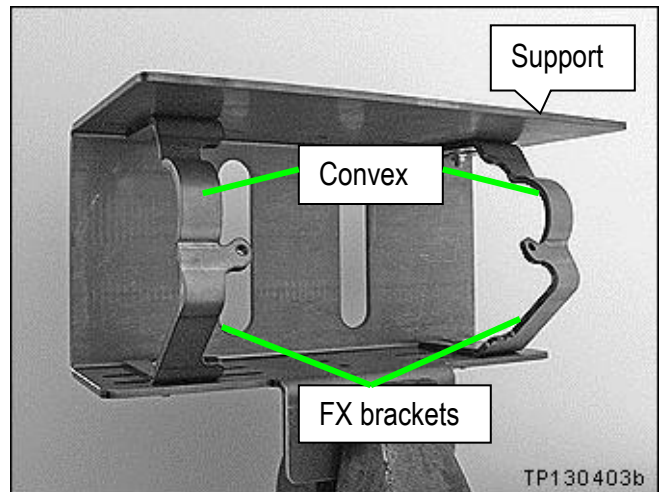

Figure Y2

4. Attach the module to the FX brackets in the support as shown.
  - Use bolts and nuts supplied with the support.
  - Make sure the arrow on the bag is pointing down.

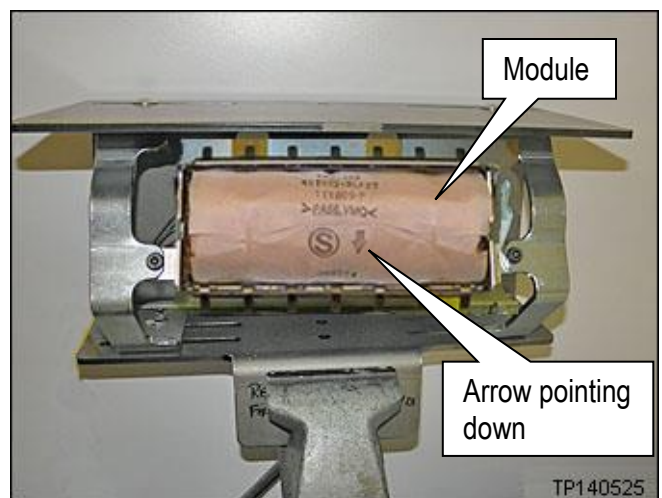

Figure Y3



5. Make sure the module is centered in the support.

**NOTE:** Centering the module in the support will allow access to the inflator securing nuts through the slots in the support.

6. Tighten all of the mounting bolts and nuts that hold the module and brackets to the support.

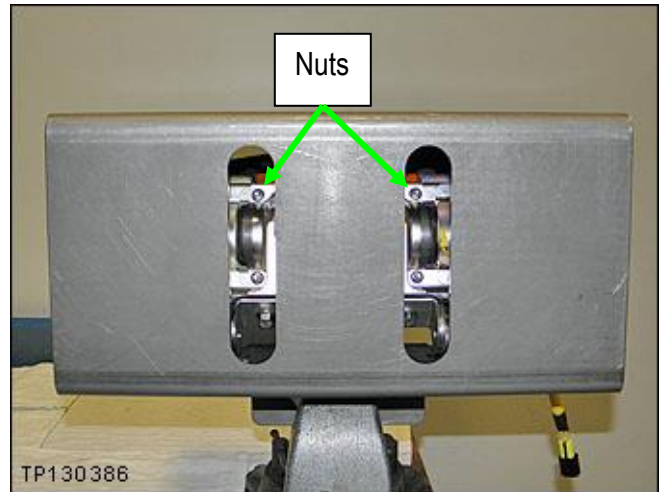

Figure Y4

**WARNING:** Work from behind and to the sides of the support.

7. Carefully cut a few inches of the yellow corrugated harness cover in the area shown.

- **Do not** cut the wires inside the corrugated cover.

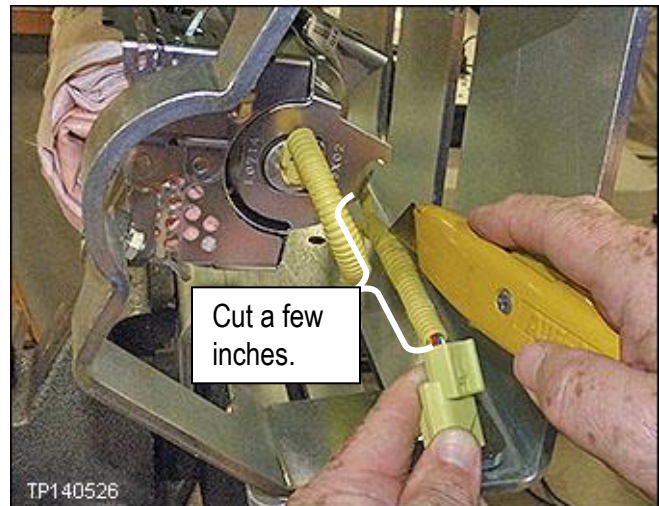

Figure Y5

8. Attach 2 shorting pins to the inflator harness as shown.

- Make sure to pair the wires from each end of the inflator.

**Blue with White**

**Red with Yellow**

- Use an insulation displacement type wire connector as a shorting pin.
- Refer to the Parts Information for additional connector/shorting pin information.

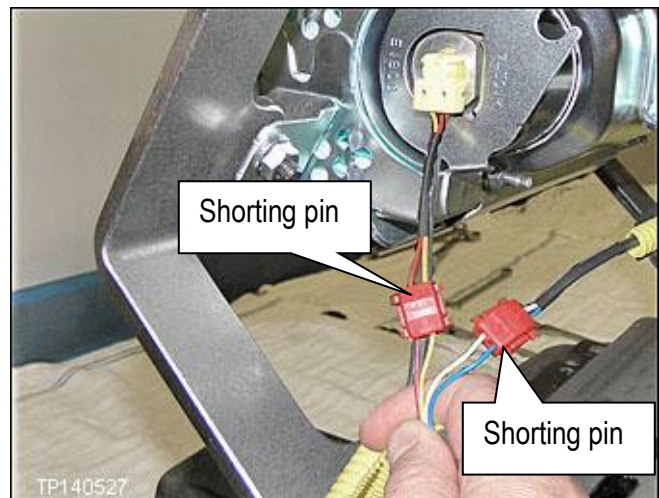

Figure Y6

9. Cut off the connector end of the harness.



Figure Y7

10. Remove the 4 nuts from the module that hold the inflator in place (see Figures Y8 and Y9).
  - Use a ratchet and extension.



Figure Y8

- Remove the 4 nuts.

**NOTE:** These nuts will not be reused.

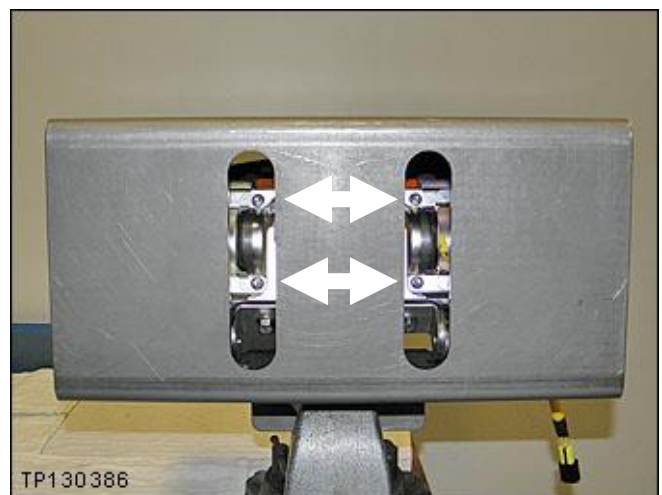

Figure Y9

11. Remove the inflator stopper.

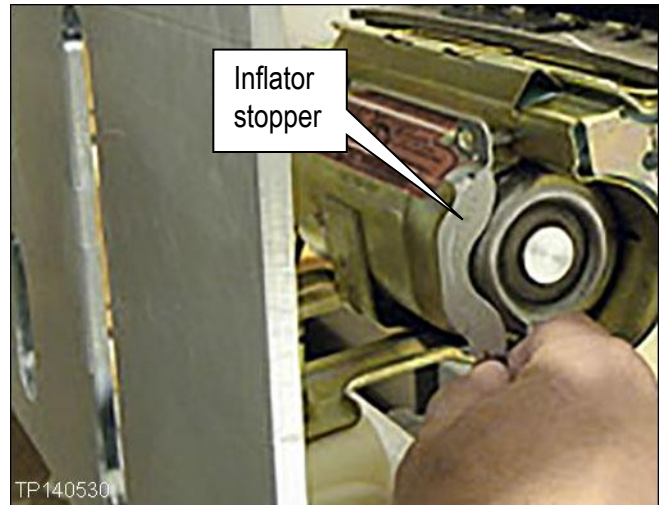

Figure Y10

12. Push the left side of the inflator out of the module.

- Twist the inflator to a position that will allow the connector and harness to fit through the opening.

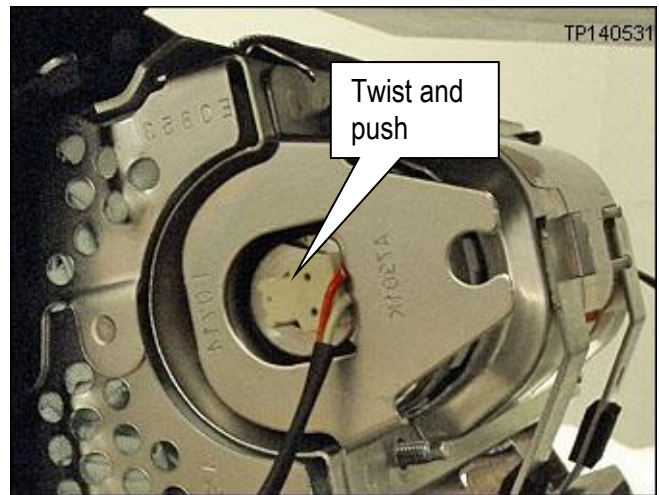

Figure Y11

13. Pull the inflator completely out of the module from the right side.

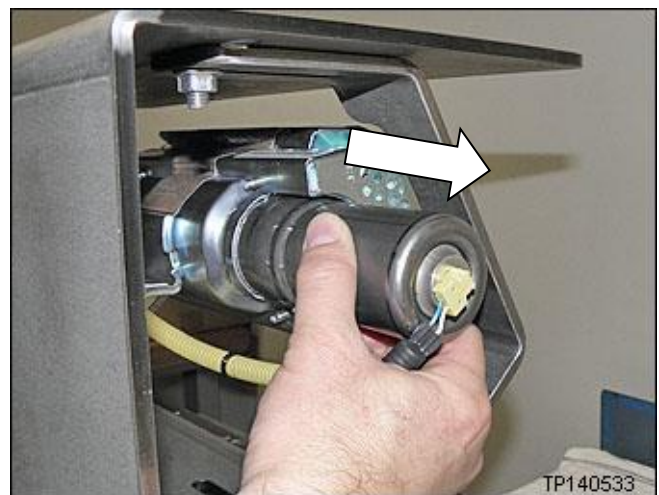

Figure Y12



14. Set the old inflator in the clean working area and make sure it does not roll and fall to the floor.

**NOTE:**

- Follow the return instructions provided by Takata.
- Return instructions provided by Takata are attached to this bulletin on page 39.

15. Remove the new inflator from the box.

16. Slide the new inflator into the module from the right side.



Figure Y13

17. Make sure the inflator is positioned / oriented correctly as shown.

- **The flat side of the inflator end (on the left side) must align with the flat side of the inflator housing.**

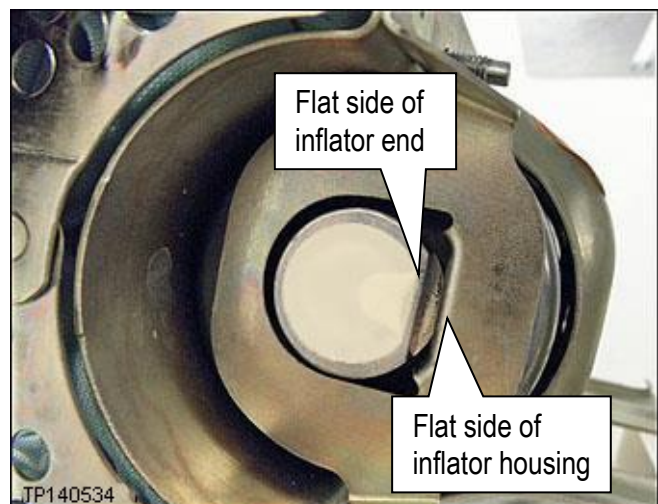

Figure Y14

18. Install the inflator stopper and 4 inflator securing nuts finger tight (see Figure Y15).

- Make sure to **use new nuts**.
- New nuts are included with the new inflator.

19. Make sure the inflator is pushed all the way into its housing – no gap on the left side (see Figure Y15).

20. Make sure there is no gap between the inflator stopper and the inflator on the right side (see Figure Y15).

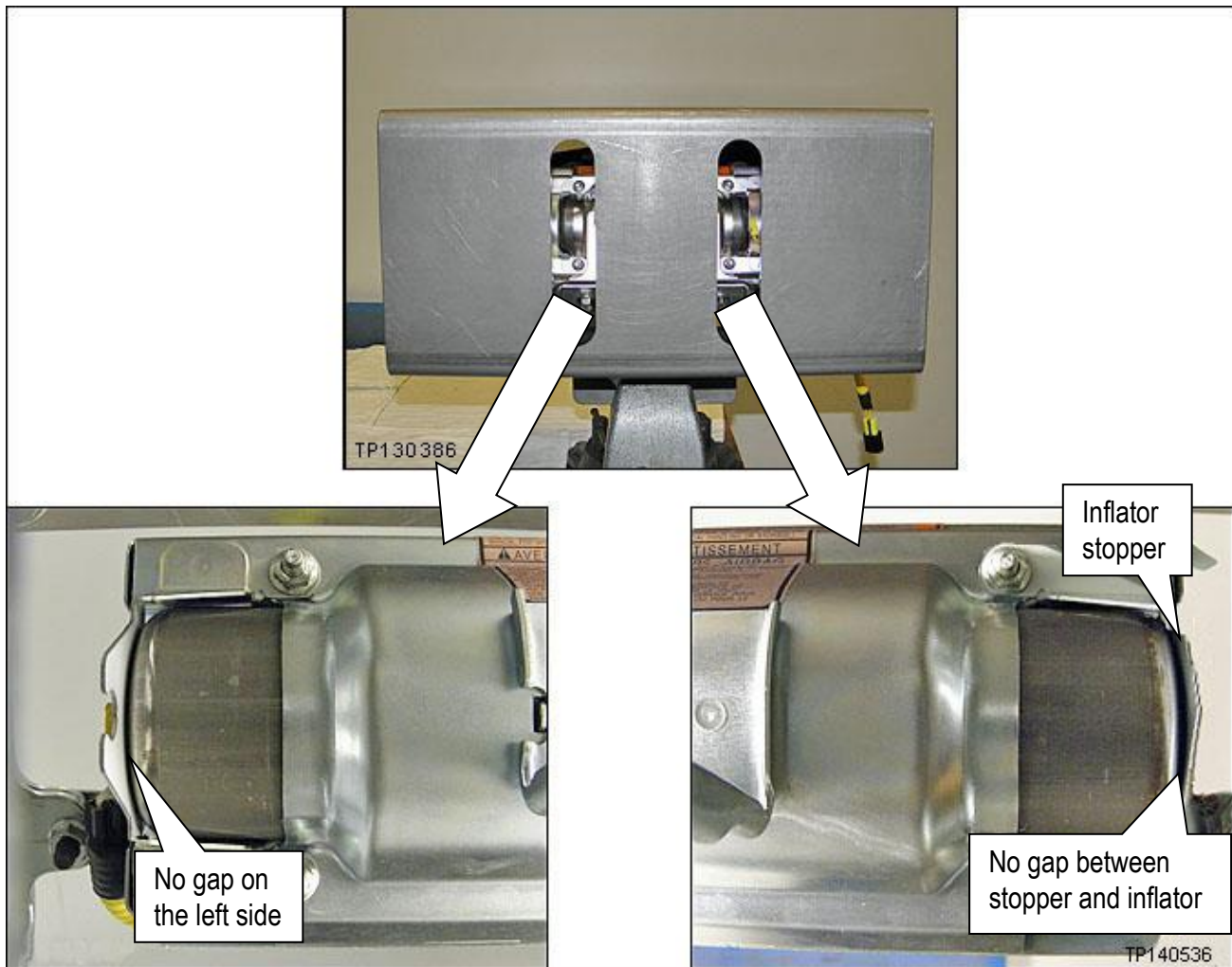

Figure Y15

21. Torque the 4 inflator securing nuts.

- Torque nuts to:  
3.9 N•m (0.39 kg-m, **34 in-lb.**).
- **Torque in the order shown.**

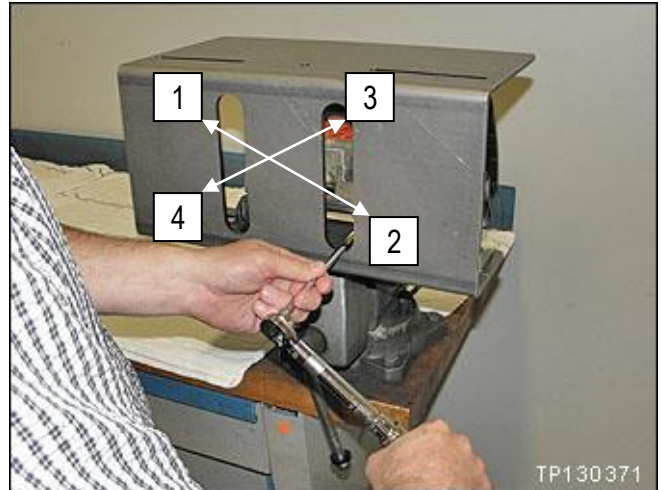

Figure Y16

**IMPORTANT:**

- In the next step, on the next page, you will be attaching the new harness to the new inflator.
- Once the inflator connector is attached to the inflator, it cannot be disconnected.
- **Make sure to attach the connectors to the correct ends of the inflator (see Figure Y17).**

22. Attach the new harness to each end of the inflator.

- Remove the dust proof stickers covering the ends of the inflator.
- Refer to Figures Y17, Y18, and Y19.

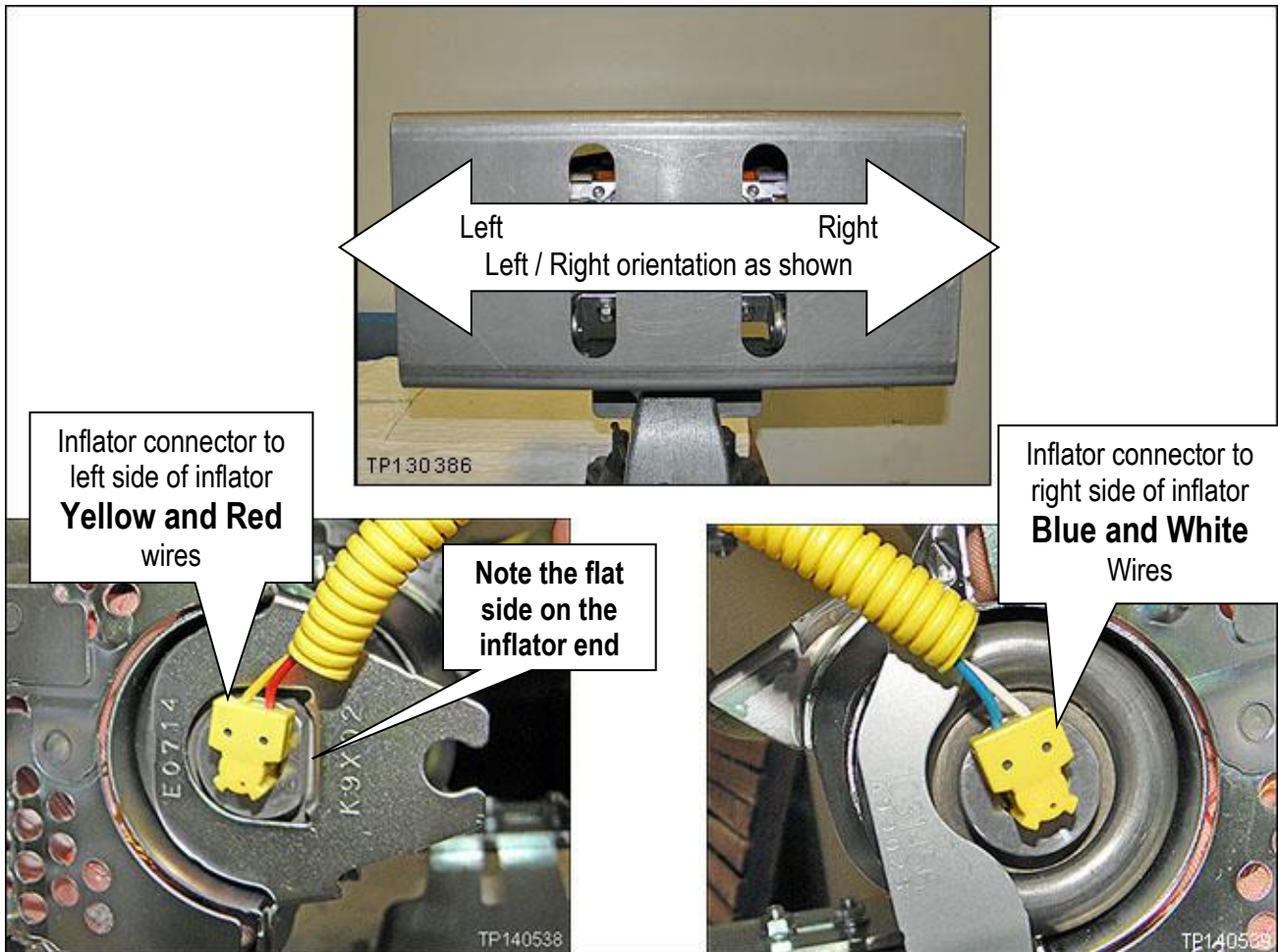

Figure Y17

- Make sure the T shape at the inflator end aligns with the T shape of the connector.

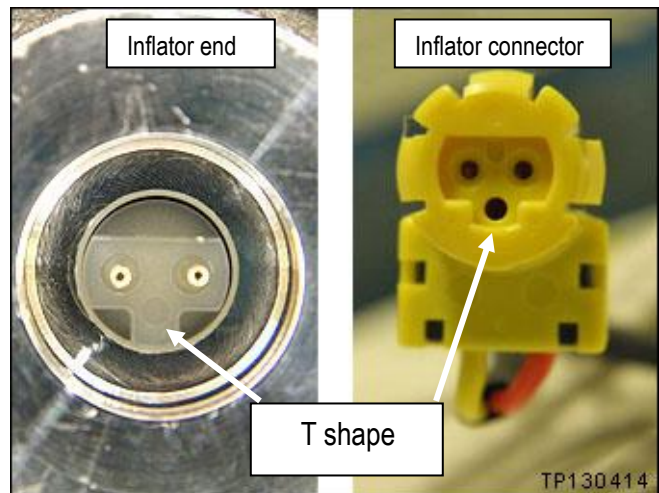

Figure Y18



- Make sure harness connector is fully engaged / seated (see Figure Y19).

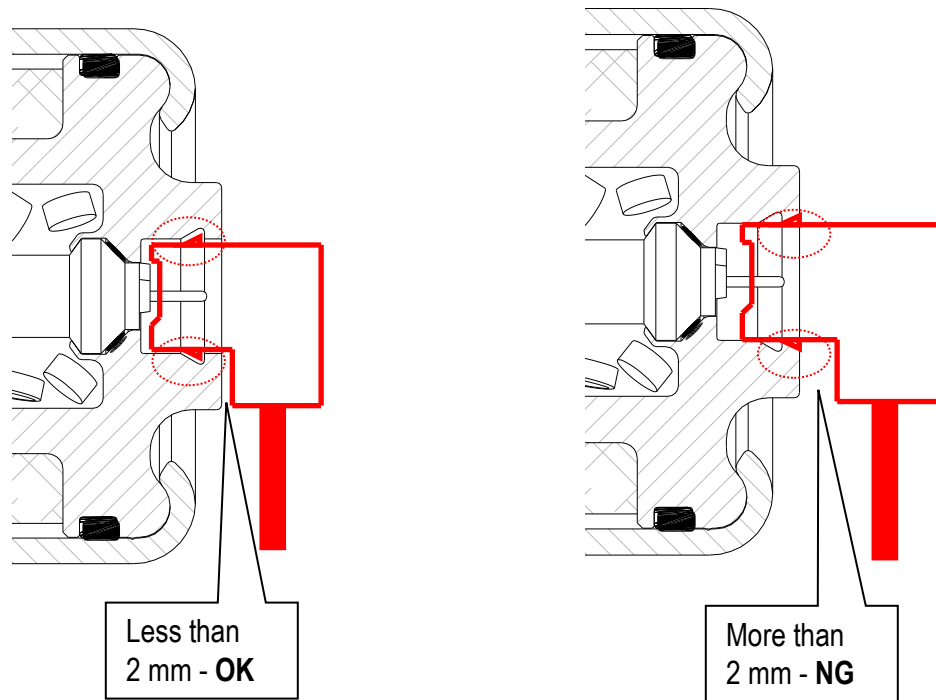

Figure Y19

23. Remove the module from the support and set it on the clean working area.

24. Clip the harness into the harness guides.

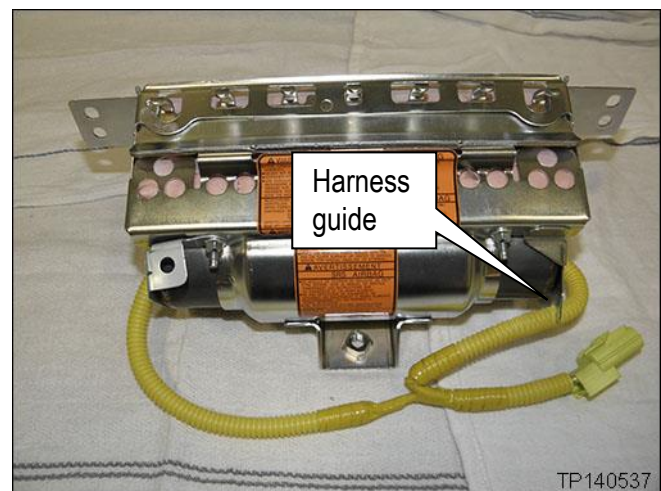



Figure Y20

**NOTE:**

- Make sure to return the removed (old / non-deployed) inflator in the box that the new inflator came in.
- Follow the return instructions provided by Takata.
- Return instructions provided by Takata are attached to this bulletin on page 39.

## PARTS INFORMATION

Model and Year	Description	PART #	Quantity
2003-2004 I35	INFLATOR-AIR BAG ASST (Includes inflator, module mounting bolts, and inflator securing nuts)	K8561-7999B	1
2003-2005 FX35/45			
2006-2007 M			
2003-2004 I35	HARNESS KIT	B4167-2Y00A	1
2003-2005 FX35/45		B4A67-CG00A	1
2006-2007 M		B4A67-EH50C	1
<b>Shorting Pin</b> (Insulation Displacement Connector for 22-18 gauge wire)  		NAPA item # 784566  Grainger Item # 4YT50  or equivalent available from local auto supply	2

### NOTE:

- Make sure to return the removed (old / non-deployed) inflator in the box that the new inflator came in.
- Follow the return instructions provided by Takata.
- Return instructions provided by Takata are attached to this bulletin on page 39.

## CLAIMS INFORMATION

Submit a "CM" line claim using the following claims coding:

CAMPAIGN ("CM") I.D.	DESCRIPTION	OP CODE	FRT
R1704	I35 - Remove and replace front passenger air bag inflator	R17040	0.8 hrs.

OR

CAMPAIGN ("CM") I.D.	DESCRIPTION	OP CODE	FRT
R1704	FX - Remove and replace front passenger air bag inflator	R17041	1.1 hrs.

OR

CAMPAIGN ("CM") I.D.	DESCRIPTION	OP CODE	FRT
R1704	M - Remove and replace front passenger air bag inflator	R17049	2.7 hrs.

## EXPENSE CODE

CODE	DESCRIPTION	MAXIMUM AMOUNT
041	Shorting Pin (Insulation Displacement Connector for 22-18 gauge wire)	\$0.50

# Takata Document

## NOTE

NOTE: International (including Mexico and Canada), Hawaii, Alaska, Puerto Rico, and US Virgin Islands dealers **CANNOT** follow below shipping instructions. Instead, dealerships in these locations **MUST** contact the following Takata/Menlo USA representative directly for shipping instructions: Miguel Prigadaa – Tel#: 210-250-5078 or Email: [MLGTakataRestrains\\_International@XPO.com](mailto:MLGTakataRestrains_International@XPO.com)

NOTE: For Continental US 48 State dealerships, please follow steps 1-8 below.

- Specific to Step 4 below:
  - Follow step 4a if you receive the updated NON-FedEx label. Proceed to step 5.
  - Follow step 4b if you receive the FedEx label. Proceed to step 5.

### 1. Shipping Documents

#### a) Box Label

- Supplied with each Kit
- To be affixed to each box



#### b) Over-pack Label

- To be supplied by XPO.
- To be affixed to the outside of each pallet



#### c) Bill of Lading

- To be supplied by XPO.
- Print 2 copies: 1 for Dealer Records, 1 for LTL Driver



#### d) ERG Document

- To be supplied by XPO.
- To be provided by the Dealer to the LTL Driver for each shipment



### 5. Shipping Instructions – Prepare the Pallet

- Accumulate and palletize Kits
- Arrange Kits on Pallet as pictured here
  - 20 boxes per row/layer (5x4)
  - 10 rows/layers per pallet (200 boxes)
- Shrink-wrap Kits to Pallet
- Affix Over-pack Label on (1) side of Pallet (Not on Top)



### 6. Shipping Instructions – Schedule LTL Pickup

- Upon Accumulating 200 kits (1 Over-pack/Pallet) Minimum
  - Call XPO at 1-210-250-5079
  - If 200 Kits have not been accumulated in 30 days, please call XPO for direction
- Have the following information Available
  - Dealer #
  - Quantity of Over-packs/Pallets
  - Quantity of Passenger Inflator Kits on each Pallet
  - Email Address where shipping Documentation can be received

### 2. Packing Instructions

a) Confirm box is in acceptable condition. If a new box is needed, follow the New Box instructions located in Box 8 of this page.

b) Place the un-deployed air bag inflator in the "cradle" of the box insert.



### 7. Shipping Instructions – Ship

- Give 1 Copy of BOL and 1 Copy of ERG to Driver
- Retain 1 Copy of BOL for Dealership records and archive for 2 Years

### 3. Closure Instructions

a) Close the top box flap, per box closure instructions located on front panel of box.



### 8. Requesting a New Box / Shipping Labels

If a new box or replacement shipping labels are needed, please contact the representative listed below by phone or email to request replacement materials.

Primary Contact: Armando Gonzalez - Tel #: 210-250-5079

E-Mail: [SCFieldaction.14305@xpo.com](mailto:SCFieldaction.14305@xpo.com)

To help expedite your request, please be prepared to provide the following information:

- Serial number on the original box
- What Type of shipping material needed
  - Replacement Box
  - Two Part Return Label
  - Bill of Lading
  - ERG Form
- Dealer Shipping Information
  - Contact name
  - Dealer Address
  - Phone Number



### 4a. Shipping Instructions – Label each Box

a) New Labels will begin shipping in each kit starting mid June, 2015

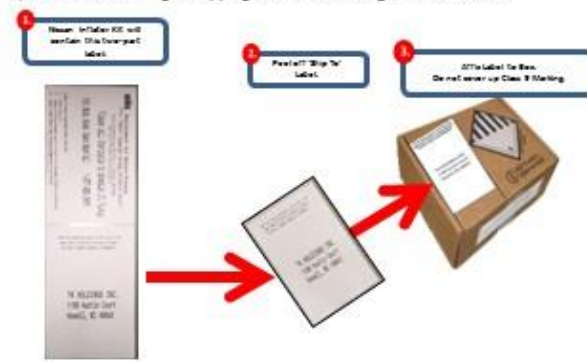



## 2006 – 2008 FX; FRONT PASSENGER AIR BAG MODULE

### REQUIRED SPECIAL TOOL

Quick Scan Tool (J-52352)

- Each retailer has been shipped one Quick Scan Tool (J-52352).
- Additional tools can be obtained from Tech-Mate at 1-800-662-2001.



Figure A

## SERVICE PROCEDURE

**IMPORTANT:** Follow all cautions, warnings, and notes in the Electronic Service Manual (ESM) when working on or near a Supplemental Restraint System (SRS), such as an air bag.

**CAUTION:** Handle interior trim carefully to avoid damage. Work with clean hands and clean tools to avoid dirt and stains. Use protective covers as needed.

1. Write down the radio settings.

Presets	1	2	3	4	5	6
AM						
FM 1						
FM 2						
SAT 1						
SAT 2						
Bass	Treble		Balance	Fade	Speed Sen. Vol.	

2. Record (write down) any other customer settings that will be lost when the battery is disconnected.
  - Refer to the Electronic Service Manual (ESM), section GI-General Information, for a listing of systems that may lose settings or memory when disconnecting the 12V battery.
    - Look in the GI section index for ADDITIONAL SERVICE WHEN REMOVING BATTERY NEGATIVE TERMINAL.
    - This list often includes items such as audio, HVAC, power windows, clock, etc.
3. Turn the ignition OFF.
4. Disconnect both battery cables, negative cable first.
5. Wait at least 3 minutes.

6. Remove the new passenger air bag module (module) from its packing and register the module number as follows:
- The new module is listed in the Parts Information.

- a. Attach the quick scan tool (J-52352) to your CONSULT PC USB port.

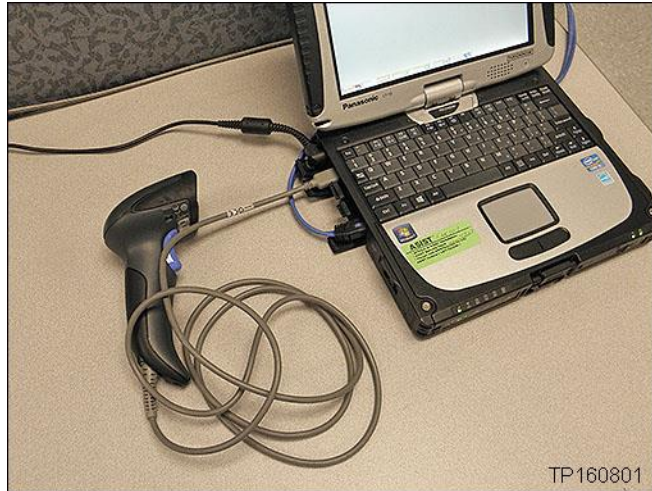

Figure 1

- b. On the left side of the ASIST main menu, select **Tech Support Info**, then **Inventory Vehicle Actions**.

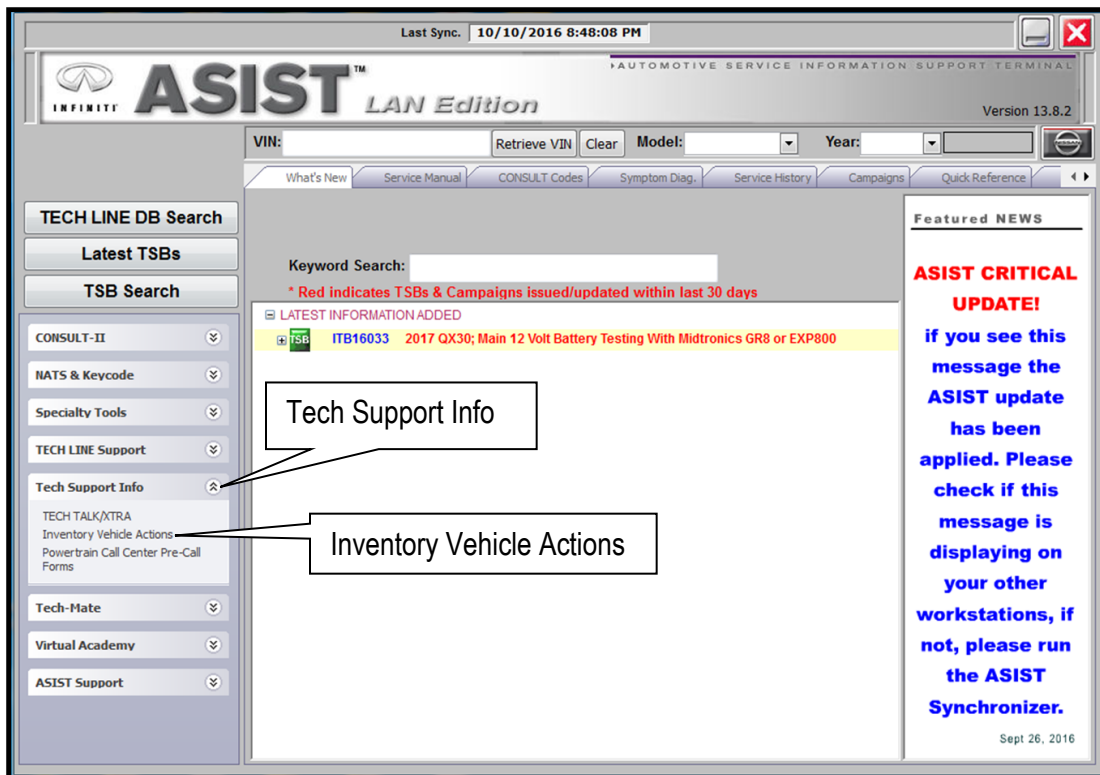

Figure 2

c. Select **CLICK HERE** (Air Bag to VIN Registration).



Figure 3



d. Use the quick scan tool to scan the bar code (VIN) on the B-pillar label.

- Make sure the label is clean.

**NOTE:**

- Some labels may not scan quickly.
- Hold the scan tool approximately 6 inches away from the label.
- Hold the trigger down until the label is read (this may take several seconds).



Figure 4

- VIN will automatically populate (see Figure 5).
- If needed, VIN can be entered manually.

**Airbag to VIN Registration**

11/28/2016 1:36:32 PM

**Please enter/scan the VIN and Airbag Inflator Serial Number**

**Dealer Code**

**Key Number**

**VIN**

**Airbag Serial Number**

Step f; see next page.  
(Select submit after both fields are populated).

Figure 5

- e. Use the quick scan tool to scan the bar code (serial number) on the new air bag module.
  - The serial number will automatically populate (see Figure 5 on previous page).



Figure 6

**NOTE:**

- If needed, the serial number can be entered manually.
- Don't use the asterisks.

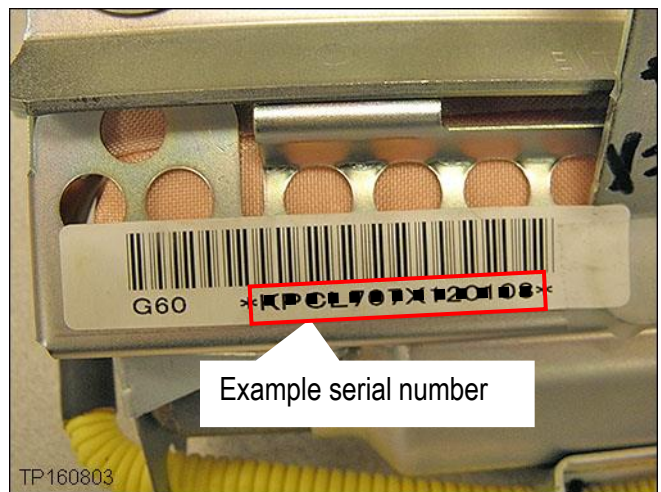

Figure 7

- f. Select **Submit** on the ASIST screen (see Figure 5 on the previous page).

7. Replace the front passenger air bag module with the new one.

- Refer to the Electronic Service Manual (ESM), section SRS-Supplemental Restraint System, for replacement information.

8. Re-connect both battery cables – positive cable first.

9. Reset/reinitialize systems as needed.

- Refer to the Electronic Service Manual (ESM), section GI-General Information, for a listing of systems that require reset/initialization after reconnecting the 12 V battery.
- Look in the GI section index for ADDITIONAL SERVICE WHEN REMOVING BATTERY NEGATIVE TERMINAL.
- This list often includes items such as radio, power windows, clock, sunroof, etc.

10. Turn the ignition from OFF to ON and observe the air bag warning light:

- Light should illuminate for 7 seconds and then go out.

**NOTE:** If the Air Bag Warning light does not operate as described above there may be an issue not covered by this campaign. Refer to ASIST and the ESM for additional diagnostic and repair information.

11. Make sure to return the removed (old / non-deployed) module in the box that the new module came in.

- Follow the return instructions provided by Takata.
- Return instructions provided by Takata are attached to this bulletin on the next page.

## PARTS INFORMATION

DESCRIPTION	PART #	QUANTITY
MODULE ASSY-AIR BAG, ASSIST (Front passenger air bag module)	K8515 - CL71A	1

## CLAIMS INFORMATION

Submit a “CM” line claim using the following claims coding:

CAMPAIGN (“CM”) I.D.	DESCRIPTION	OP CODE	FRT
R1704	Replace front passenger air bag module	R17043	0.8 hrs.

# Takata Document

## NOTE

NOTE: **International (including Mexico and Canada), Hawaii, Alaska, Puerto Rico, and US Virgin Islands dealers CANNOT** follow below shipping instructions. Instead, dealerships in these locations **MUST** contact the following Takata/Menlo USA representative directly for shipping instructions: Miguel Prigadaa – Tel #: 210-250-5078 or Email: [MLGTakataRestrains\\_International@XPO.com](mailto:MLGTakataRestrains_International@XPO.com)

NOTE: For Continental US 48 State dealerships, please follow steps 1-8 below.

### 1. Shipping Documents

#### a) Box Label

- address
- To be affixed to each box

TK HOLDING INC.  
1199 Austin Court  
Howell, MI 48843

#### b) Over-pack Label

- To be supplied by XPO.
- To be affixed to the outside of each pallet



#### c) Bill of Lading

- To be supplied by XPO.
- Print 2 copies: 1 for Dealer Records, 1 for LTL Driver



#### d) ERG Document

- To be supplied by XPO.
- To be provide by the Dealer to the LTL Driver for each shipment

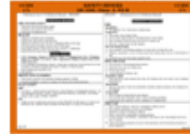

### 5. Shipping Instructions – Prepare the Pallet

- Accumulate and palletize 50 modules
- Arrange modules on Pallet as shown in example picture Below.
- Shrink-wrap modules to Pallet
- Affix Over-pack Label (supplied by XPO ) on (1) side of Pallet (Not on Top)



### 6. Shipping Instructions – Schedule LTL Pickup

- Upon Accumulating 50 modules (1 Over-pack/Pallet) Minimum
  - Call XPO at 1-210-250-5079
  - If 50 modules have not been accumulated in 30 days, please call XPO for direction
- Have the following Information Available
  - Dealer #
  - Quantity of Over-packs/Pallets
  - Quantity of Passenger modules on each Pallet
  - Email Address where shipping Documentation can be received

### 2. Packing Instructions

a) Confirm box is in acceptable condition. If a new box is needed, follow the New Box instructions located in Box 8 of this page.

b) Place the un-deployed air bag module in the "cradle" of the box insert.



### 3. Closure Instructions

a) Close the top box flaps.



b) Securely seal



### 4. Shipping Instructions - Label each Box

a) Affix address to top of box.

Affix Address to Box.  
Do not cover up Class 9 Marking.

TK HOLDING INC.  
1199 Austin Court  
Howell, MI 48843



### 7. Shipping Instructions – Ship

- Give 1 Copy of BOL and 1 Copy of ERG to Driver
- Retain 1 Copy of BOL for Dealership records and archive for 2 Years

### 8. Requesting a New Box

If a new box is needed, please contact the representative listed below by phone or email to request replacement materials.

Primary Contact: XPO Rep. - Tel #: 210-250-5079

E-Mail: [SCFieldaction.14305@xpo.com](mailto:SCFieldaction.14305@xpo.com) To help expedite your request, please be prepared to provide the following information:

a) What Type of shipping material needed

- Replacement Box
- Two Part Return Label
- Bill of Lading
- ERG Form

b) Dealer Shipping Information

- Contact name
- Dealer Address
- Phone Number



# 2008 – 2010 M FRONT PASSENGER AIR BAG INFLATOR

## REQUIRED SPECIAL TOOLS

Air Bag Module Support (J-51315-KIT)

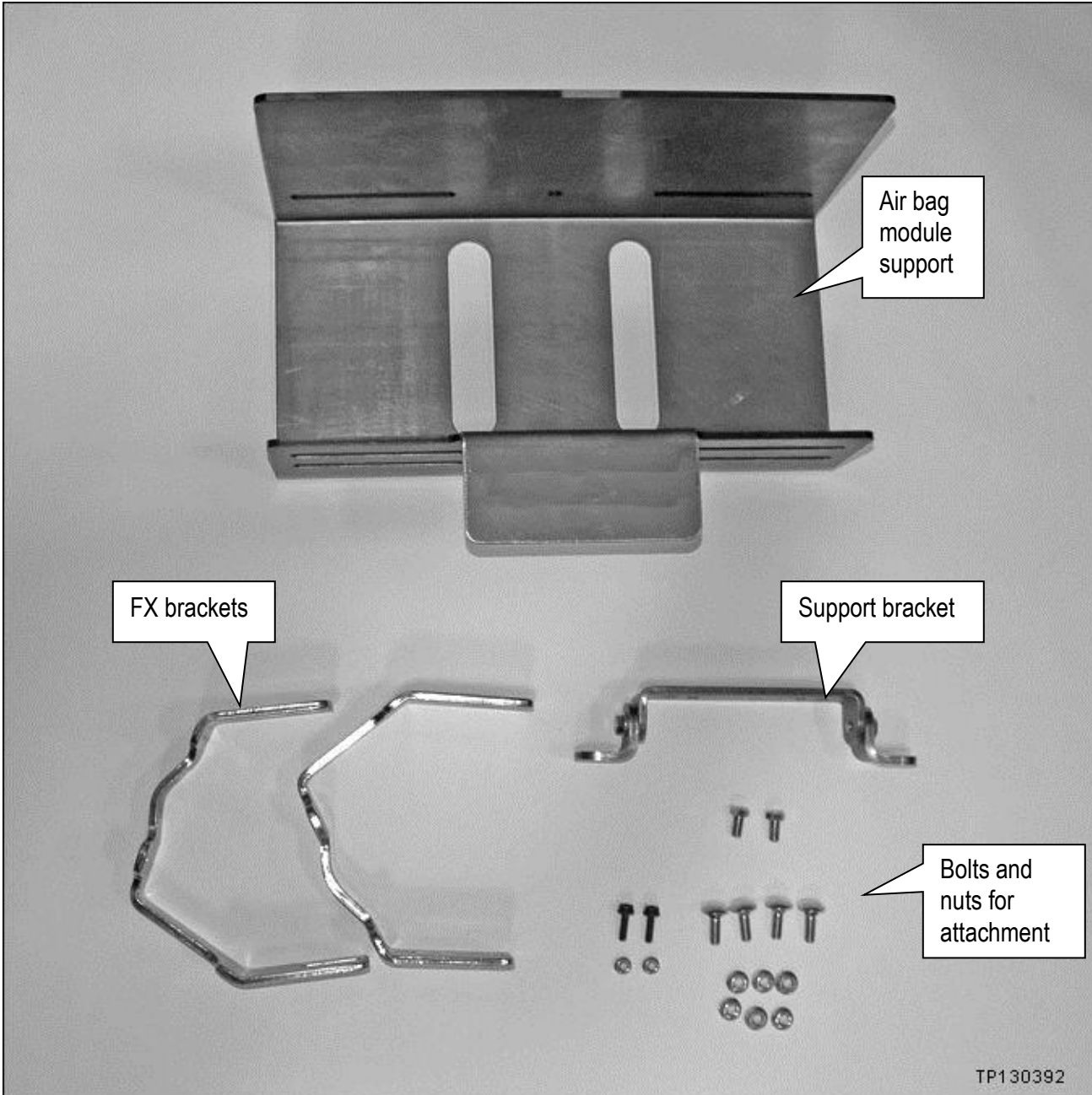

Figure A

### Quick Scan Tool (J-52352)

- Each retailer has been shipped one Quick Scan Tool (J-52352).
- Additional tools can be obtained from Tech•Mate at 1-800-662-2001.



Figure B

## SERVICE PROCEDURE

1. Write down the radio settings.

Presets	1	2	3	4	5	6
AM						
FM 1						
FM 2						
SAT 1						
SAT 2						
Bass	Treble		Balance	Fade	Speed Sen. Vol.	

2. Turn the ignition OFF.
3. Disconnect both battery cables, negative cable first.
4. Wait at least 3 minutes.
5. Register the new inflator serial number as follows.
  - The new inflator is listed in the Parts Information.

- a. Attach the quick scan tool (J-52352) to your CONSULT PC USB port.

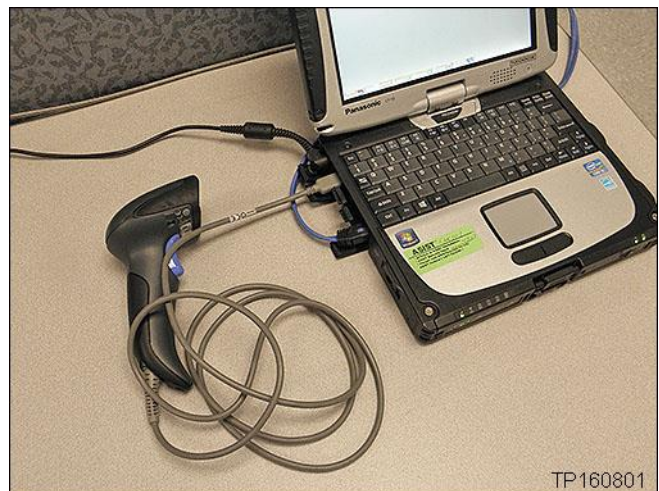

Figure 1

- b. On the left side of the ASIST main menu, select **Tech Support Info**, then **Inventory Vehicle Actions**.

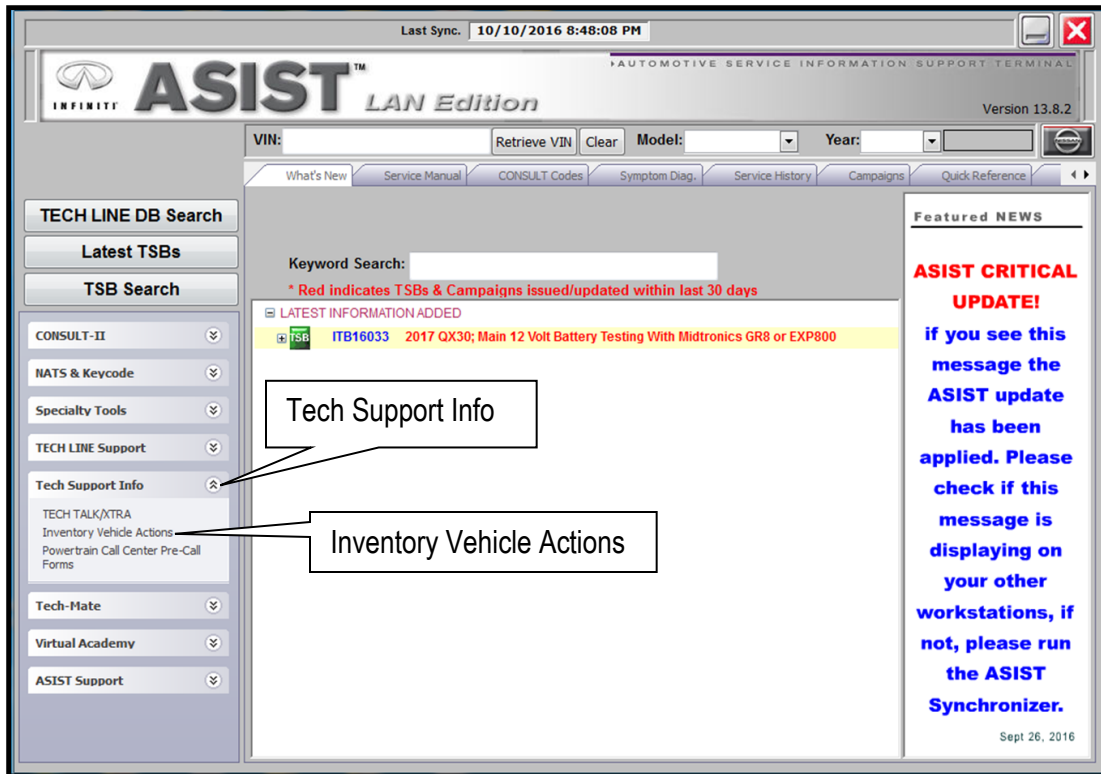

Figure 2

- c. Select **CLICK HERE** (Air Bag to VIN Registration).



Figure 3



d. Use the quick scan tool to scan the bar code (VIN) on the B-pillar label.

- Wipe any dirt/debris from bar code before scanning.

**NOTE:**

- Some labels may not scan quickly.
- Hold the scan tool approximately 6 inches away from the label.
- Hold the trigger down until the label is read (this may take several seconds).



Figure 4

- VIN will automatically populate (see Figure 5).
- If needed, VIN can be entered manually.

[Airbag to VIN Registration](#)  
11/28/2016 1:36:32 PM

**Please enter/scan the VIN and Airbag Inflator Serial Number**

Dealer Code      ■■■■

Key Number      ■■■

VIN     

Airbag Serial Number     

Step f; see next page.  
(Select submit after both fields are populated).

Figure 5

- e. Use the quick scan tool to scan the bar code (serial number) on the new inflator shipping box..
- The serial number will automatically populate (see Figure 5 on previous page).

**NOTE:** If needed, the serial number can be entered manually.

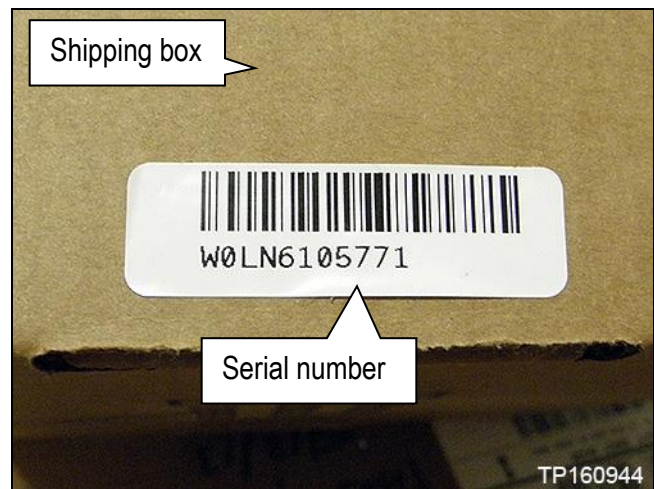

Figure 6

- f. Select **Submit** on the ASIST screen (see Figure 5 on the previous page).
6. Remove the passenger air bag module (module) from the vehicle.
- Refer to the appropriate Electronic Service Manual (ESM) for module removal information.

**IMPORTANT:** Follow all cautions, warnings, and notes in the Electronic Service Manual (ESM) when working on or near a Supplemental Restraint System (SRS), such as an air bag.

**CAUTION:** Handle interior trim carefully to avoid damage. Work with clean hands and clean tools to avoid dirt and stains. Use protective covers as needed.

7. Set the module in a clean working area.
- NOTE:** Do not set the module with cover facing down.
8. Securely mount the air bag module support (support) in a vice (see Figure 7).

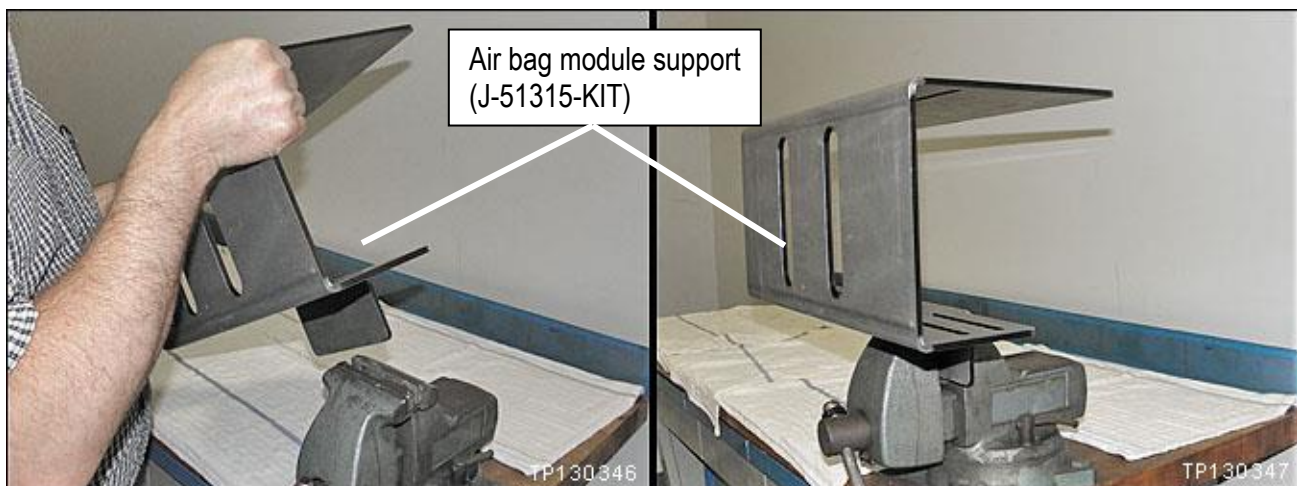

Figure 7

**WARNING:** Work from behind and to the sides of the support.

## Remove the Inflator from the Air Bag Moduel Assembly

**WARNING:** Wear safety glasses while performing inflator replacement.

1. Unclip the harness from the harness guides.

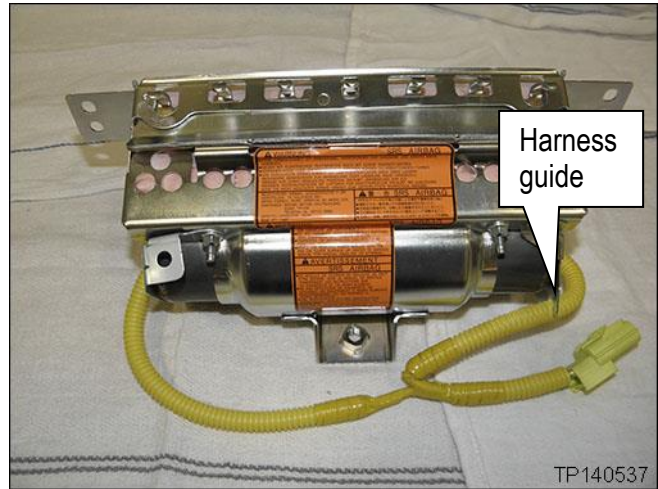

Figure 8

2. Attach the FX brackets to the support as shown.
  - Make sure the convex parts of the brackets are in the UP position.
  - Use bolts and nuts supplied with the support.
  - Leave the bolts/nuts slightly loose to allow for positioning of the module.

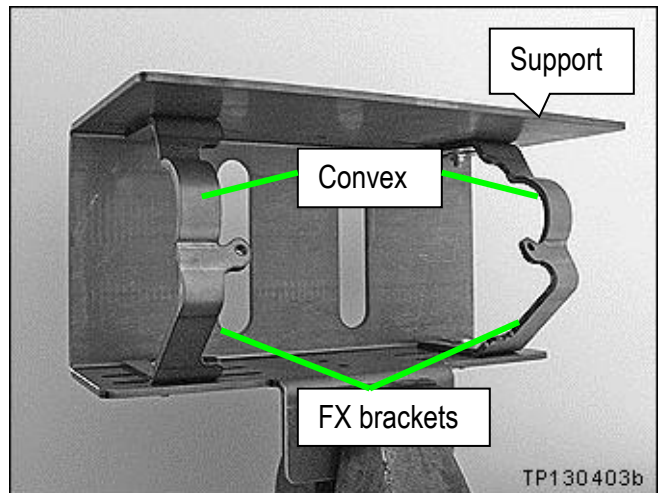

Figure 9

3. Attach the module to the FX brackets in the support as shown.
  - Use bolts and nuts supplied with the support.
  - Make sure the arrow on the bag is pointing down.

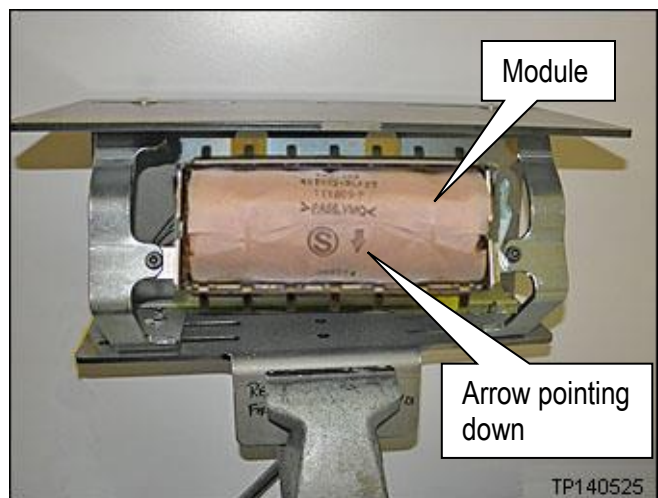

Figure 10



4. Make sure the module is centered in the support.

**NOTE:** Centering the module in the support will allow access to the inflator securing nuts through the slots in the support.

5. Tighten all of the mounting bolts and nuts that hold the module and brackets to the support.

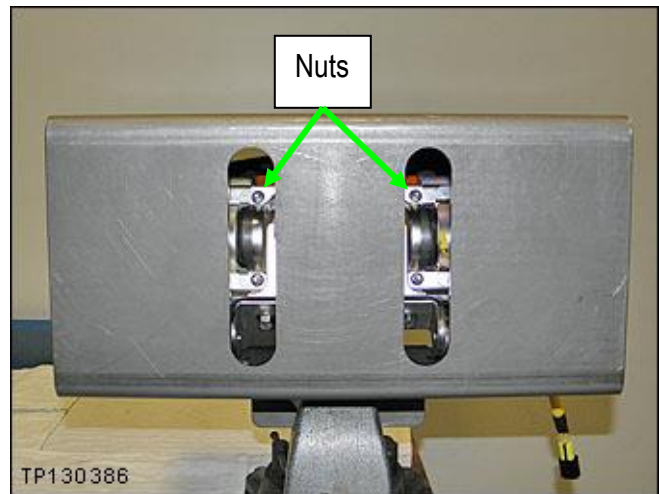

Figure 11

**WARNING:** Work from behind and to the sides of the support.

6. Carefully cut a few inches of the yellow corrugated harness cover in the area shown.
  - **Do not** cut the wires inside the corrugated cover.

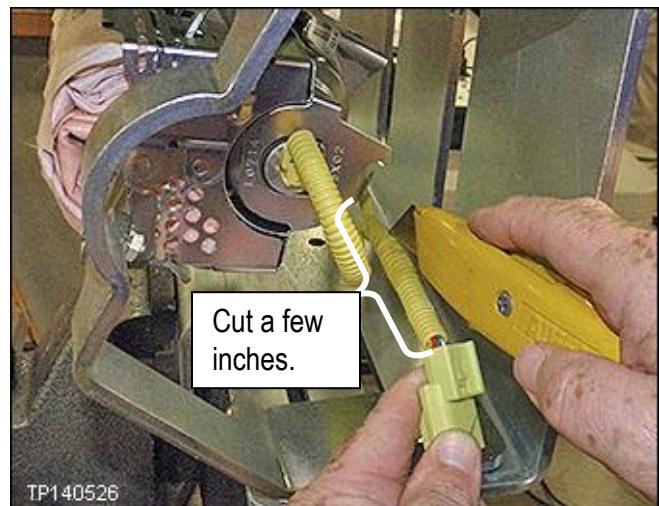

Figure 12

7. Attach 2 shorting pins to the inflator harness as shown.
  - Make sure to pair the wires from each end of the inflator.
    - Blue with White**
    - Red with Yellow**
  - Use an insulation displacement type wire connector as a shorting pin.
  - Refer to the Parts Information for additional connector/shorting pin information.

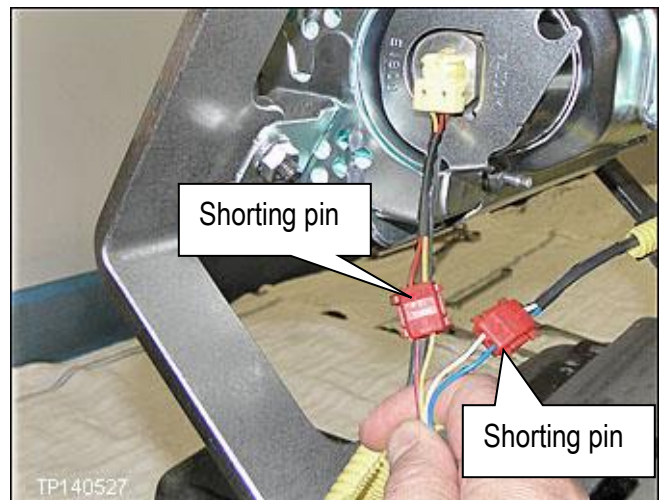

Figure 13



- Cut off the connector end of the harness.



Figure 14

- Remove the 4 nuts from the module that hold the inflator in place (see Figures 15 and 16).
  - Use a ratchet and extension.



Figure 15

- Remove the 4 nuts.  
**NOTE:** These nuts will not be reused.

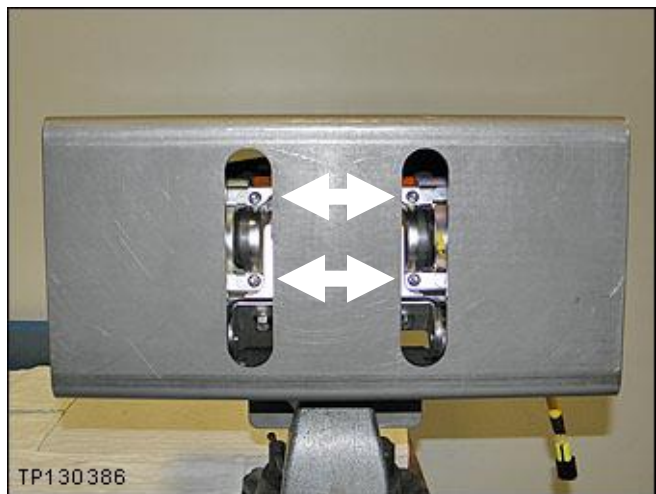

Figure 16

10. Remove the inflator stopper.

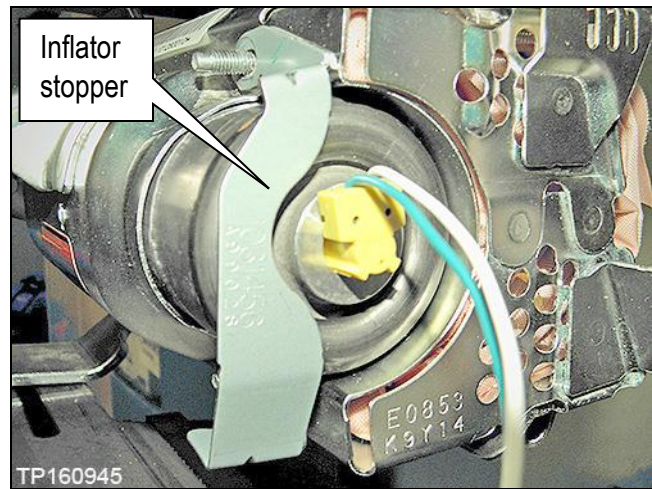

Figure 17

11. Push the left side of the inflator out of the module.

- Twist the inflator to a position that will allow the connector and harness to fit through the opening.

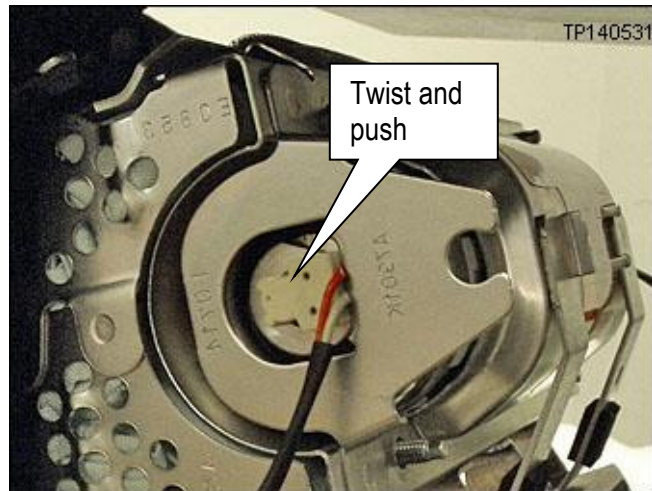

Figure 18

12. Pull the inflator completely out of the module from the right side.

13. Set the old inflator in the clean working area and make sure it does not roll and fall to the floor.

**NOTE:**

- Follow the return instructions provided by Takata.
- Return instructions provided by Takata are attached to this bulletin on page 21.

14. Remove the module from the air bag module support and place on a clean surface.



Figure 19

## Remove the Inflator Stopper Bracket

1. Remove the left side inflator stopper bracket as follows:

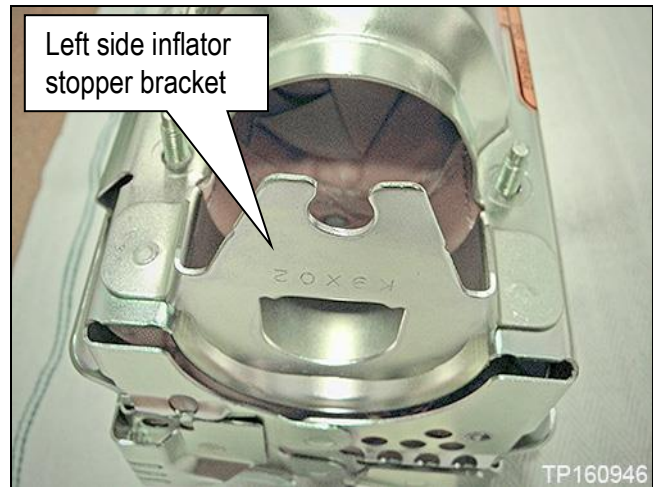

Figure 20

**IMPORTANT:** Do NOT use air tools or other types of power tools to make any of the following cuts.

- a. Cut left and right vertical attachments.
  - Left side shown cut in Figure 22.
  - Use an appropriate tool.

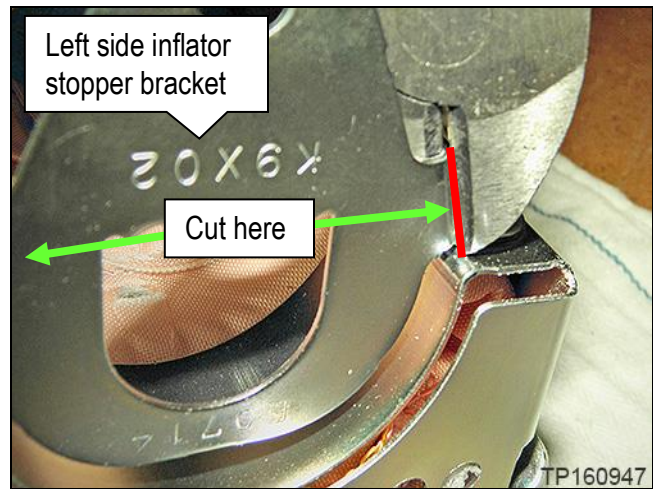

Figure 21

- b. Cut the remaining tabs at the points shown in Figure 22.

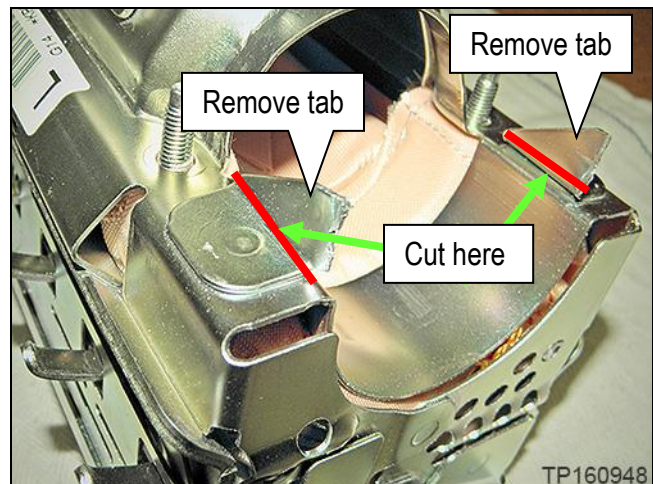

Figure 22



- c. Apply non-woven tape over the sharp edges from the removed left side inflator stopper bracket.
- Non-woven tape is supplied in the harness kit

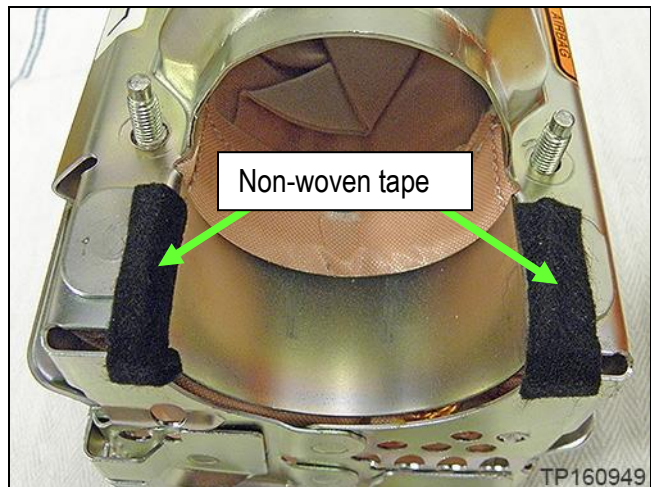

Figure 23

- d. Install the new left side inflator stopper bracket (shown in Figure 24) with new nuts finger tight.
- Make sure to **use new nuts**.
  - New nuts and brackets are included in the harness kit.

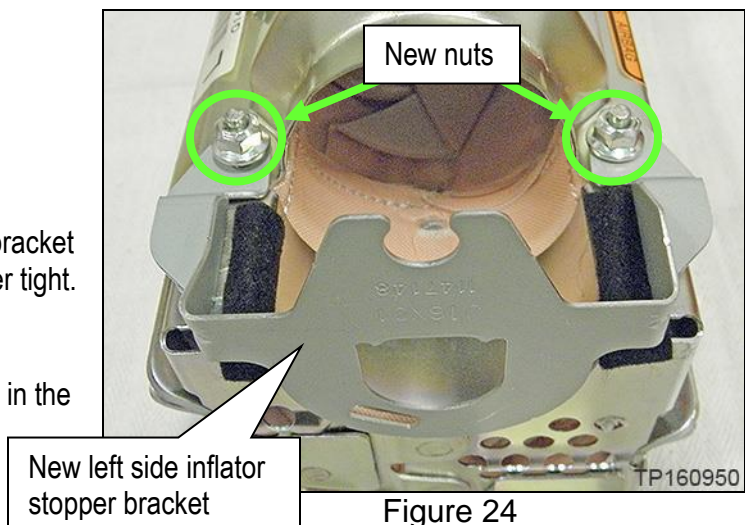

Figure 24

- e. Place the module back into the air bag module support with the arrow pointing down.

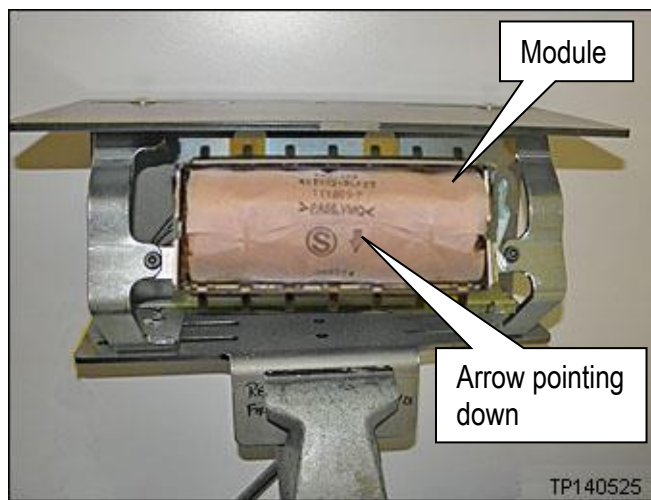

Figure 25



## Reinstall Inflator into Module

1. Remove the new inflator from the box.
2. Insert the new inflator large end first, as shown in Figure 26 from the right side.

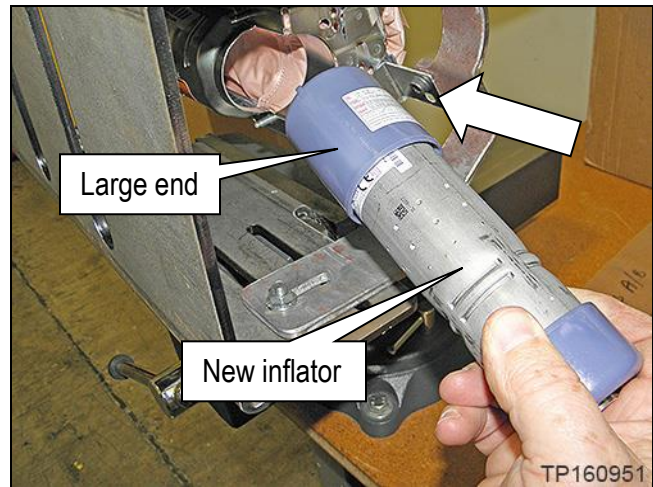

Figure 26

3. Align the inflator tab and then insert it through the hole in the left side inflator stopper bracket.

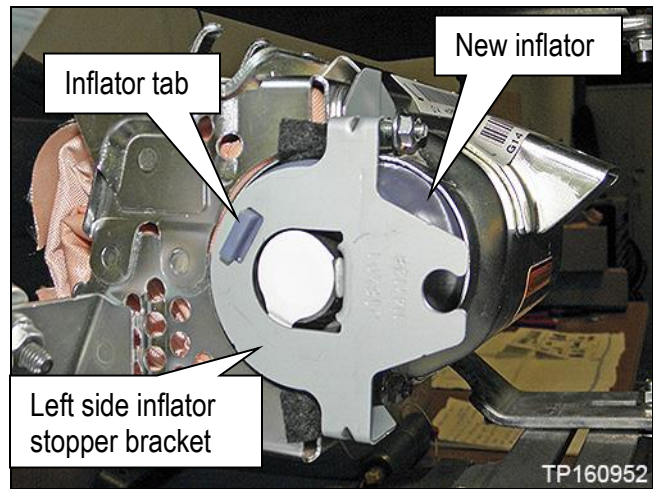

Figure 27

4. Install the new right side inflator stopper bracket (shown in Figure 28) with nuts finger tight.
  - Make sure to **use new nuts**.
  - New nuts are included in the new harness kit.

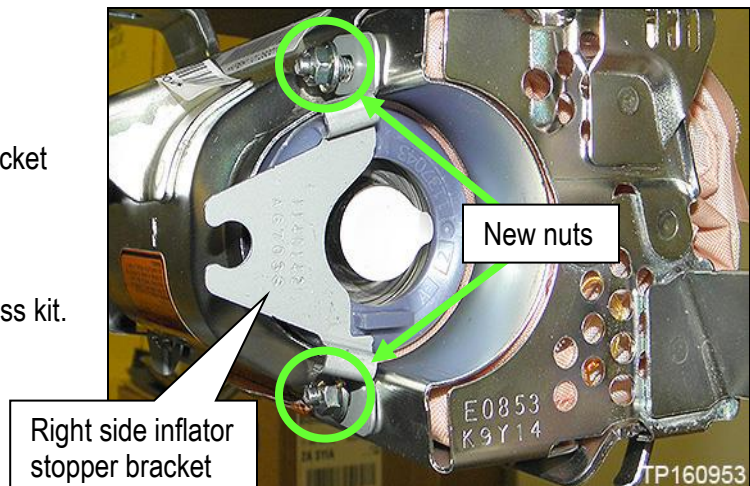

Figure 28

5. Push the new right side inflator stopper bracket and Inflator into the left side inflator stopper bracket.

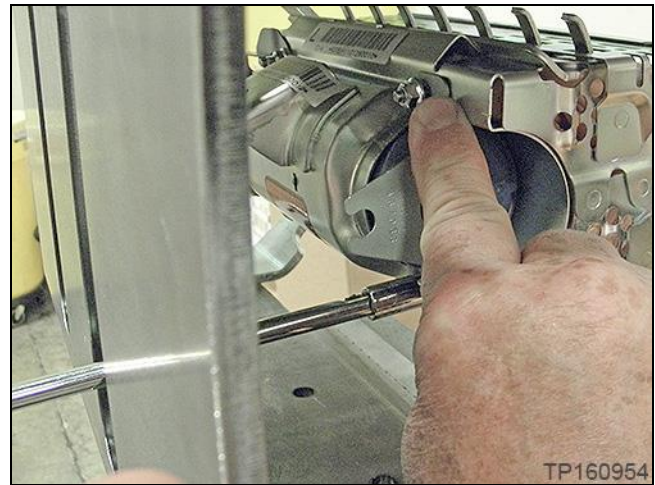

Figure 29

- Make sure the inflator is pushed all the way into its housing – no gap on the left side (see Figure 30).
- Make sure there is no gap between the inflator stopper bracket and the inflator on the right side (see Figure 30).

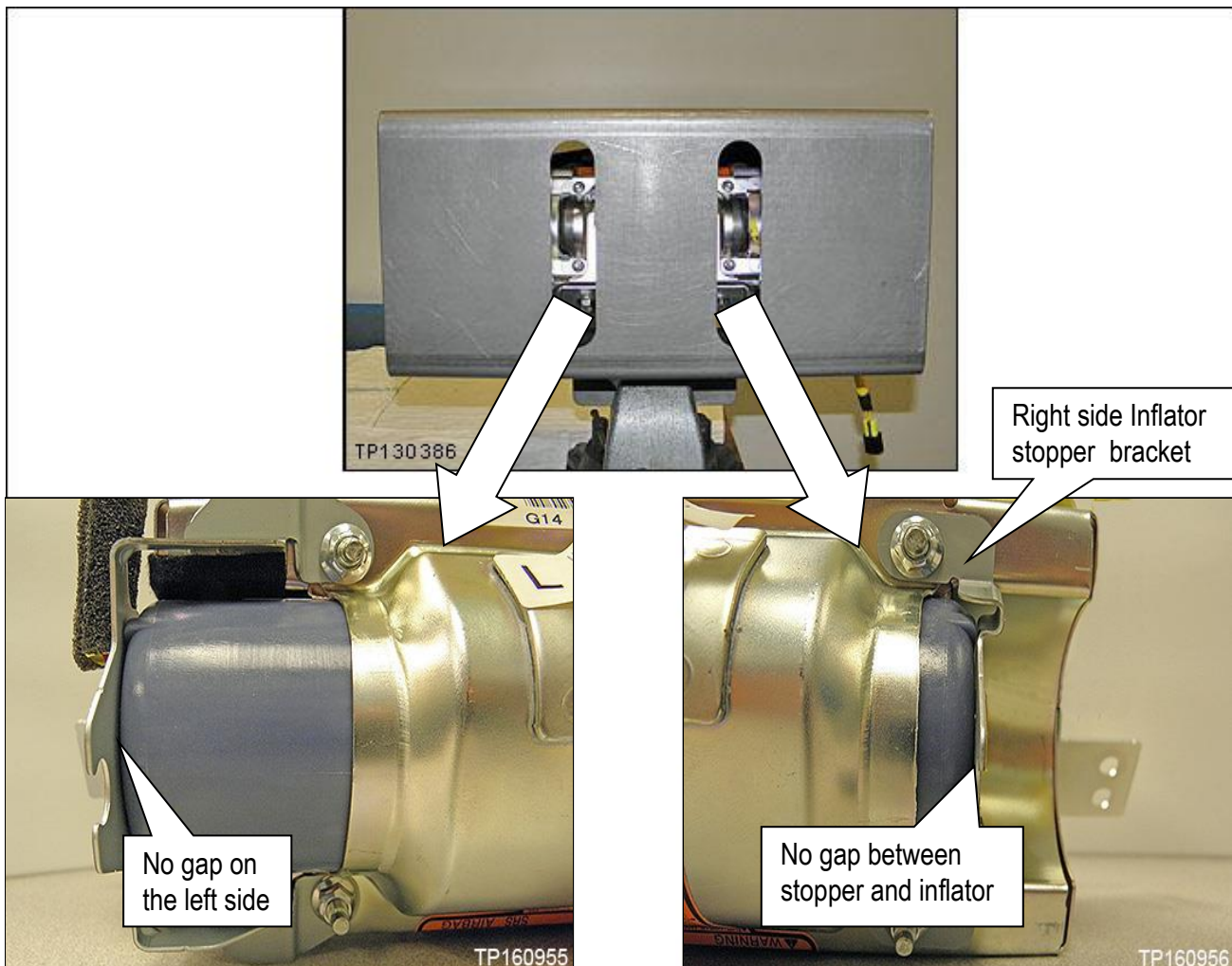

Figure 30

6. Torque the 4 inflator securing nuts.
- Torque nuts to: 3.9 N•m (0.39 kg-m, **34 in-lb**).
  - **Torque in the order shown.**

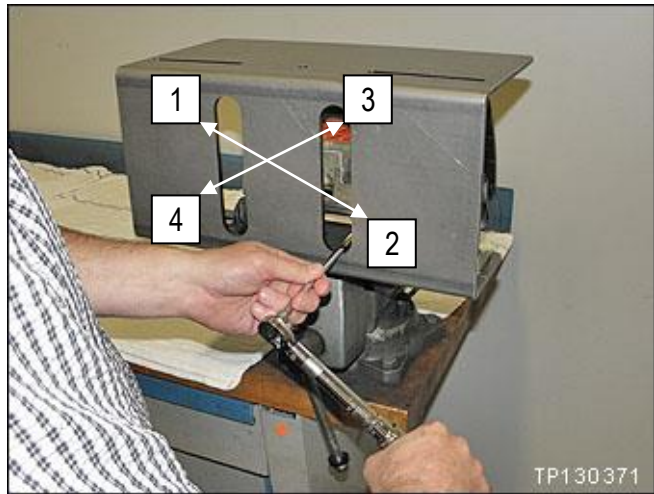

Figure 31

**IMPORTANT:**

- In the next step, on the next page, you will be attaching the new harness to the new inflator.
- Once the inflator connector is attached to the inflator, it cannot be disconnected.
- **Make sure to attach the connectors to the correct ends of the inflator (see Figure 32 and 33).**



7. Attach the new harness to each end of the inflator.
  - Remove the dust proof stickers covering the ends of the inflator.
  - Refer to Figures 32, 33, and 34.

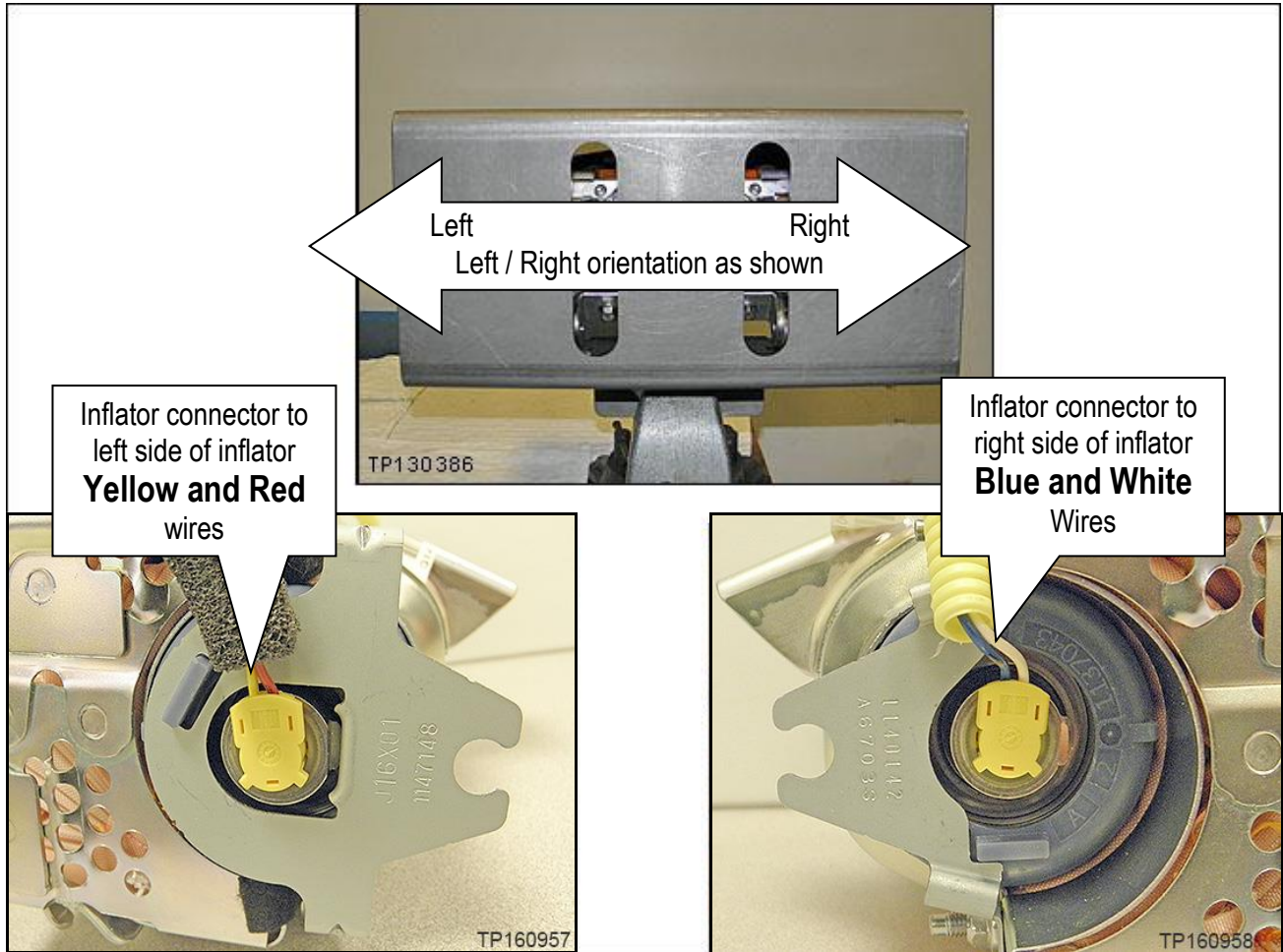

Figure 32

- Make sure the T shape at the inflator end aligns with the T shape of the connector.

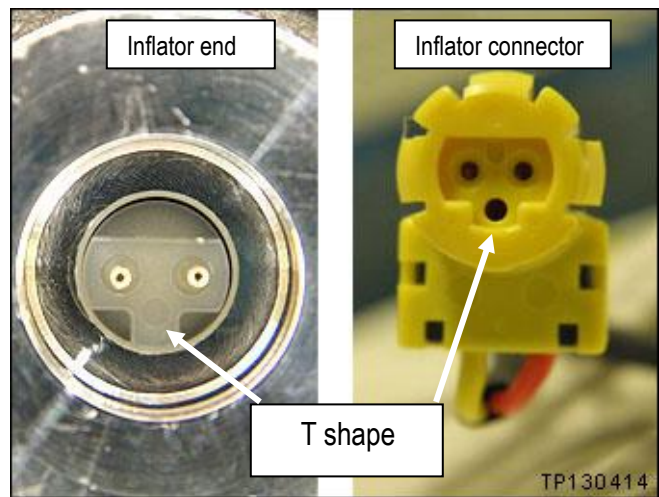

Figure 33



- Make sure harness connector is fully engaged / seated (see Figure 34).

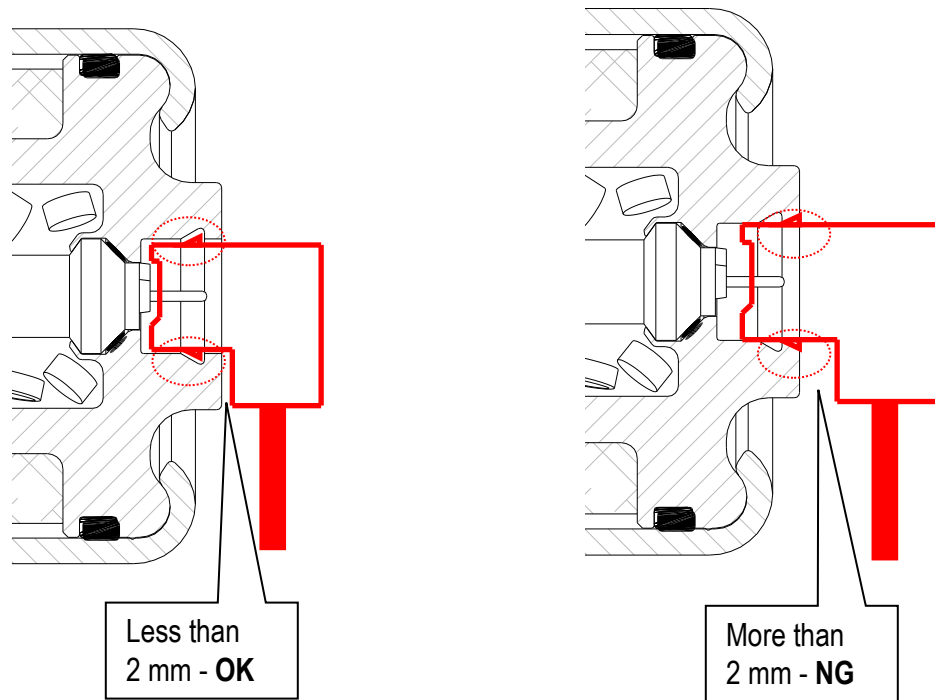

Figure 34

8. Remove the module from the support and set it on the clean working area.

9. Clip the new harness into the harness guides.

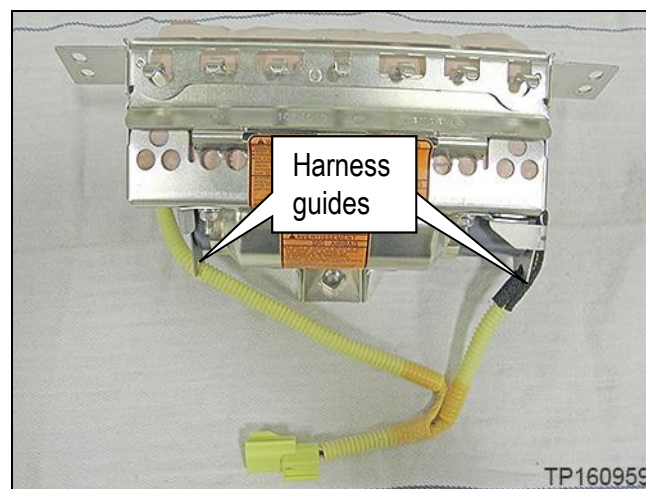

Figure 35

**NOTE:**

- Make sure to return the removed (old / non-deployed) inflator in the box that the new inflator came in.
- Follow the return instructions provided by Takata.
- Return instructions provided by Takata are attached to this bulletin on page 21.

## Reinstall Module back into Vehicle

1. Reinstall the module into the vehicle in reverse order of removal.
  - Make sure to use the new “one time use” module mounting bolts included with the new inflator.
2. Re-connect both battery cables – positive cable first.
3. Reset/reinitialize systems as needed.
  - Refer to the Electronic Service Manual (ESM), section **GI-General Information**, for a listing of systems that require reset/initialization after reconnecting the 12 V battery.
  - Look in the GI section index for **ADDITIONAL SERVICE WHEN REMOVING BATTERY NEGATIVE TERMINAL**.
  - This list often includes items such as radio, power windows, clock, sunroof, etc.
4. Turn the ignition ON and observe the air bag warning light:
  - Light should illuminate for 7 seconds and then go out.

**NOTE:** If the Air Bag Warning light does not operate as described above there may be an issue not covered by this campaign. Refer to ASIST and the appropriate Service Manual for additional diagnostic and repair information.
5. **Return the removed (old / non-deployed) inflator in the box that the new inflator arrived in.**
  - Follow the return instructions provided by Takata.
  - Return instructions provided by Takata are attached to this bulletin on page 21.

**PARTS INFORMATION**

Description	PART #	Quantity
INFLATOR-AIR BAG ASST (Passenger Air Bag Module Inflator)	98561-7999E	1
HARNESS KIT	B4A67-EH50D	1
<p><b>Shorting Pin</b> (Insulation Displacement Connector for 22-18 gauge wire)</p> 	<p>NAPA item # 784566</p> <p>Grainger Item # 4YT50</p> <p>or equivalent available from local auto supply</p>	2

**NOTE:**

- Make sure to return the removed (old / non-deployed) inflator in the box that the new inflator came in.
- Follow the return instructions provided by Takata.
- Return instructions provided by Takata are attached to this bulletin on page 21.

**CLAIMS INFORMATION**

Submit a “CM” line claim using the following claims coding:

CAMPAIGN (“CM”) I.D.	DESCRIPTION	OP CODE	FRT
R1704	<b>M</b> - Remove and replace front passenger air bag <b>inflator</b>	R17042	2.8 hrs.

**EXPENSE CODE**

CODE	DESCRIPTION	MAXIMUM AMOUNT
041	<b>Shorting Pin</b> (Insulation Displacement Connector for 22-18 gauge wire)	\$0.50

# Takata Document

## NOTE

NOTE: International (including Mexico and Canada), Hawaii, Alaska, Puerto Rico, and US Virgin Islands dealers **CANNOT** follow below shipping instructions. Instead, dealerships in these locations **MUST** contact the following Takata/Menlo USA representative directly for shipping instructions: Miguel Prigadaa – Tel#: 210-250-5078 or Email: [MLGTakataRestrains\\_International@XPO.com](mailto:MLGTakataRestrains_International@XPO.com)

NOTE: For Continental US 48 State dealerships, please follow steps 1-8 below.

- Specific to Step 4 below:
  - Follow step 4a if you receive the updated NON-FedEx label. Proceed to step 5.
  - Follow step 4b if you receive the FedEx label. Proceed to step 5.

### 1. Shipping Documents

#### a) Box Label

- Supplied with each Kit
- To be affixed to each box



#### b) Over-pack Label

- To be supplied by XPO.
- To be affixed to the outside of each pallet



#### c) Bill of Lading

- To be supplied by XPO.
- Print 2 copies: 1 for Dealer Records, 1 for LTL Driver



#### d) ERG Document

- To be supplied by XPO.
- To be provided by the Dealer to the LTL Driver for each shipment



### 5. Shipping Instructions – Prepare the Pallet

- Accumulate and palletize Kits
- Arrange Kits on Pallet as pictured here
  - 20 boxes per row/layer (5x4)
  - 10 rows/layers per pallet (200 boxes)
- Shrink-wrap Kits to Pallet
- Affix Over-pack Label on (1) side of Pallet (Not on Top)



### 6. Shipping Instructions – Schedule LTL Pickup

- Upon Accumulating 200 kits (1 Over-pack/Pallet) Minimum
  - Call XPO at 1-210-250-5079
  - If 200 Kits have not been accumulated in 30 days, please call XPO for direction
- Have the following information Available
  - Dealer #
  - Quantity of Over-packs/Pallets
  - Quantity of Passenger Inflator Kits on each Pallet
  - Email Address where shipping Documentation can be received

### 2. Packing Instructions

a) Confirm box is in acceptable condition. If a new box is needed, follow the New Box instructions located in Box B of this page.

b) Place the un-deployed air bag inflator in the "cradle" of the box insert.



### 7. Shipping Instructions – Ship

- Give 1 Copy of BOL and 1 Copy of ERG to Driver
- Retain 1 Copy of BOL for Dealership records and archive for 2 Years

### 3. Closure Instructions

a) Close the top box flap, per box closure instructions located on front panel of box.



### 8. Requesting a New Box / Shipping Labels

If a new box or replacement shipping labels are needed, please contact the representative listed below by phone or email to request replacement materials.

Primary Contact: Armando Gonzalez - Tel #: 210-250-5079

E-Mail: [SCFieldaction.14305@xpo.com](mailto:SCFieldaction.14305@xpo.com)

To help expedite your request, please be prepared to provide the following information:

a) Serial number on the original box



b) What Type of shipping material needed

- Replacement Box
- Two Part Return Label
- Bill of Lading
- ERG Form

c) Dealer Shipping Information

- Contact name
- Dealer Address
- Phone Number

### 4a. Shipping Instructions - Label each Box

a) New Labels will begin shipping in each kit starting mid June, 2015

