



MERCEDES-BENZ USA, LLC  
303 Perimeter Center North, Suite 202  
Atlanta, GA, 30346  
Phone: (770) 705-0600  
Fax: (770) 705-0117  
MBUSA.com

Service

## newschannel update

TO: Mercedes-Benz Dealer Principals, General Managers, Sales Managers, Service Managers, Parts Managers	FROM: Thomas Brunner, Department Manager, Vehicle Compliance and Analysis, Engineering Services
RE: <b>Recall Campaign 2016050008 – Check and Replace Drive Shaft on Model 190 (AMG GT-Class) MY 2016</b>	DATE: July 22, 2016

### IMPORTANT RECALL LAUNCH INFORMATION

**This Recall Campaign is being launched today and the 136 affected vehicles are flagged in VMI. One affected vehicle is in dealer inventory.**

**Parts:** Parts may be ordered as needed. Replacement rate is 20%.

**Owner Notification:** Owners will be notified by letter beginning July 29, 2016.

**What Should Customers Do:** Customers may continue to drive their vehicles until the recall is completed.

#### **What's the Issue:**

Daimler AG (DAG), the manufacturer of Mercedes-Benz vehicles, has determined that on certain MY16 AMG GT S vehicles (C190 platform), the bond between the carbon-fiber driveshaft and the engine-/transmission flange might not meet the specification. This could result in loss of torque between the engine and transmission and lead to loss of motive power, and increase the risk of a potential crash. An authorized Mercedes-Benz dealer will check the driveshaft and replace the driveshaft if necessary.

**Given this notice, it is a violation of Federal law for a dealer to sell or lease any new Model Year 2016 GT-Class covered by this notification in dealer inventory until the vehicle has been repaired.**

**Dealers are advised to check new vehicle inventory for recall campaign applicability via VMI, and repair immediately. Once the repair is complete, the vehicle may be sold or leased.**

**To enhance Customer Experience, Dealers are encouraged to utilize MBSelect for customers affected by this recall.**

When scheduling customers for an appointment please ensure that you are aware of any open campaigns in VMI so that the customer is advised about the time necessary to complete all campaigns.

**Note: VMI must always be checked before performing campaigns to verify that the campaign is required on a specific vehicle.**

Dealers may also identify vehicles subject to a campaign through NetStar by selecting "Campaign" under the Controlling tab. Only vehicles that have been retailed by the respective dealer will be displayed within this program.

While we regret any inconvenience this may cause, MBUSA is determined to maintain a high level of vehicle quality and customer satisfaction

Please refer all customer inquiries to the Customer Assistance Center at 1-800-FOR-MERCEdes (1-800-367-6372).





Mercedes-Benz

Campaign No. 2016050008, July 2016

TO: ALL MERCEDES-BENZ CENTERS

SUBJECT: **Model 190, Model Year 2016**  
**Check Drive Shaft, Replace if Necessary**

Daimler AG (DAG), the manufacturer of Mercedes-Benz vehicles, has determined, that on certain MY16 AMG GT S vehicles (C190 platform), the bond between the carbon-fiber driveshaft and the engine/transmission flange might not meet the specification. This could result in loss of torque between the engine and transmission and lead to loss of motive power, and increase the risk of a potential crash. An authorized Mercedes-Benz dealer will check the driveshaft and replace the driveshaft if necessary.

Prior to performing this Recall Campaign:

- Please check VMI to determine if the vehicle is involved in the Campaign and if it has been previously repaired.
- Please review the entire Recall Campaign bulletin and follow the repair procedure exactly as described.

Please note that Recall Campaigns **do not expire** and may also be performed on a vehicle with a vehicle status indicator.

Approximately 136 vehicles are involved.

Order No. P-RC-2016050008

This bulletin has been created and maintained in accordance with MBUSA-SLP S423QH001, Document and Data Control, and MBUSA-SLP S424HH001, Control of Quality Records.

## Procedure

### A. Replace Drive Shaft

1. Open maintenance access on engine-side drive shaft housing.
2.  Check drive shaft production number (A, Figure 1).
  - If production number is **greater** than **000322 (OK)**: Procedure is complete.
  - If production number is **less** than or **equal** to **000322 (NOT OK)**: Proceed to step 3 (below).

 **Note:**

If label is not visible start engine briefly then turn off engine and check again (repeat as necessary until label is visible).

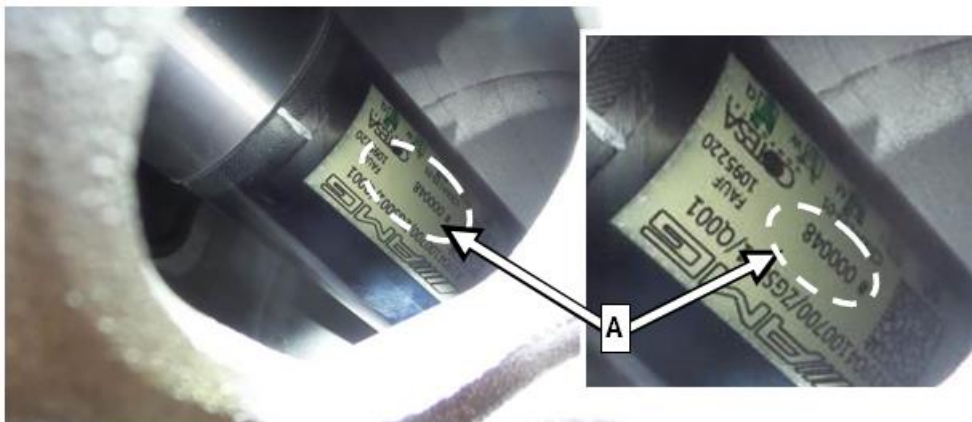



Figure 1

3.  Replace drive shaft, refer to WIS: AR41.10-P-0051MNB.

 **Notes** (regarding above WIS instructions):

- Assembly drift 190 589 00 15 00 may difficult to insert into the compensating ring when new. In this event, remove the coating on the assembly drift splines using a scotch bright pad.
- A new compensating ring (A, Figure 2) must be installed.
- Please refer to **Subject B** for supplemental instructions regarding centering compensating ring on driveshaft.

### B. Centering Compensating Ring on Drive Shaft

 **Note:**

Instructions starting on the following page are supplemental to referenced WIS instructions.

1. Clean transmission side of drive shaft end (arrow, Figure 2) of any lubricants.
2.  Slide new compensating ring (A, Figure 2) onto driveshaft (arrow) **up to end stop**.

 **Note:**

Do not remove assembly aids/fastening plates (Figure 2) at this time.

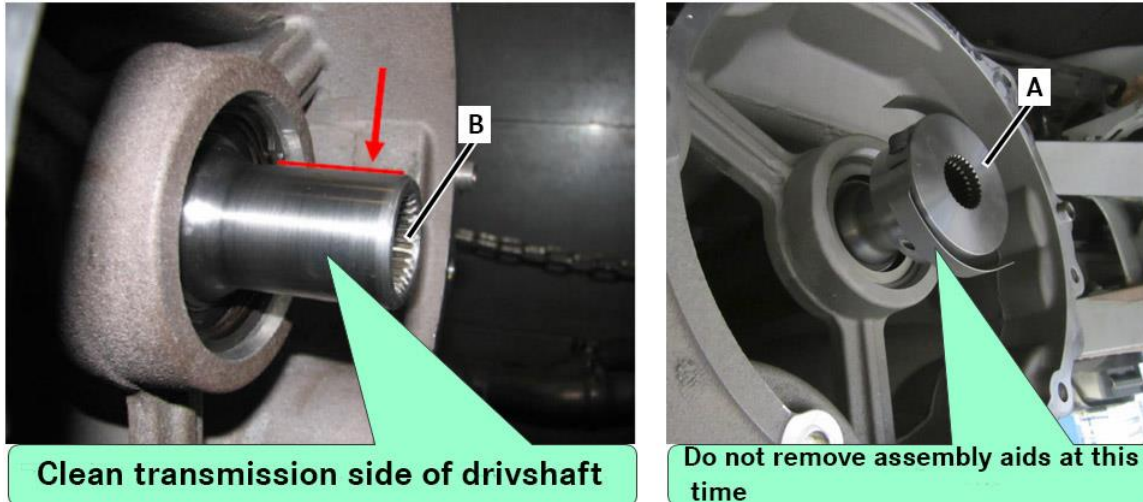



Figure 2

3. Center drive shaft gearing (B, Figure 2) and compensating ring (Figure 3) using assembly drift;  special tool: 190 589 00 15 00 (Figure 3).

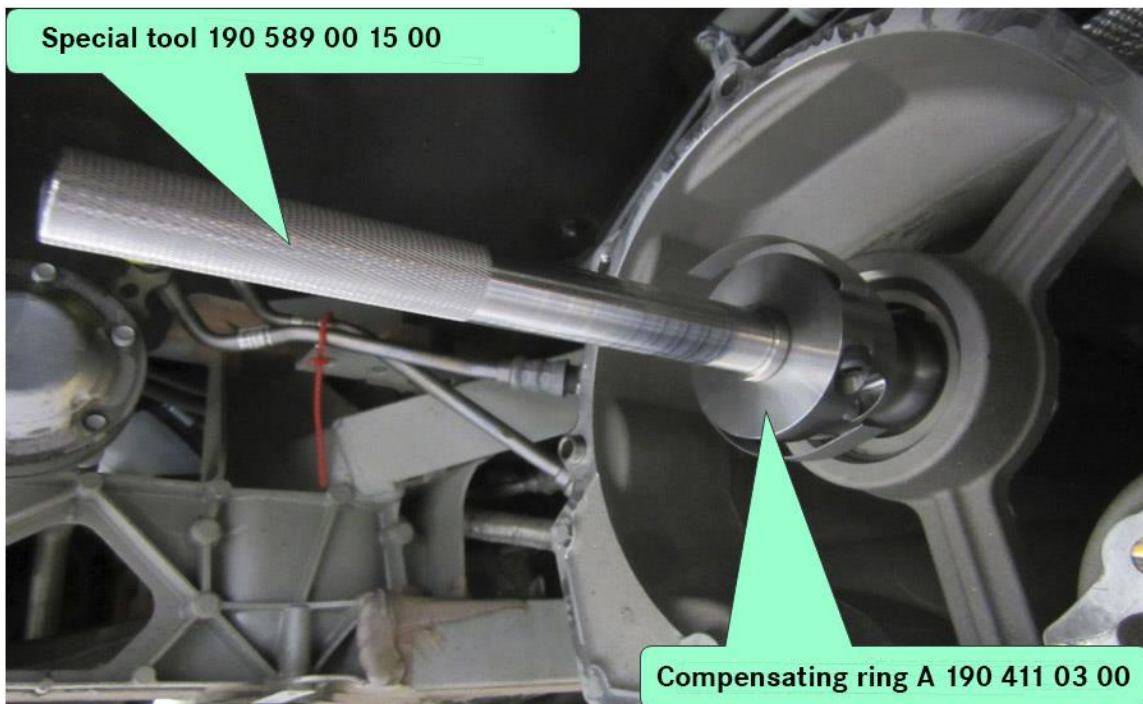

Figure 3

4. Tighten compensating ring's clamping ring (A, Figure 4) to drive shaft using **new** clamping screw (Figure 4); **Nm** torque **new** clamping screw (Figure 4) to 10 Nm. The assembly drift (special tool, Figure 3) may now be removed.

**i** Notes:

- Do **not** remove assembly aids/fastening plates (arrow, Figure 5) at this time.
- The drive shaft gearing is now synchronized with the compensating ring's gearing.
- The **new** clamping screw (Figure 4) is coated with thread locking compound.
- Part number for **new** clamping screw (Figure 4) is: N 000000 006551

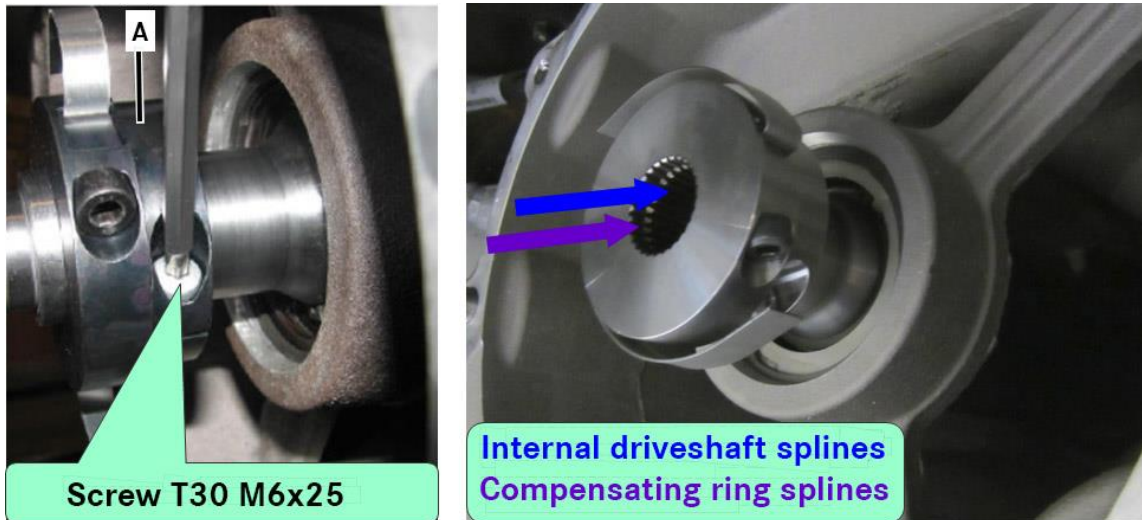

Figure 4

**i** Note:

After reinstalling transmission:

- Remove assembly aids (arrow, Figure 5).
- Reinstall rubber plug (A) into lower opening in drive shaft housing.

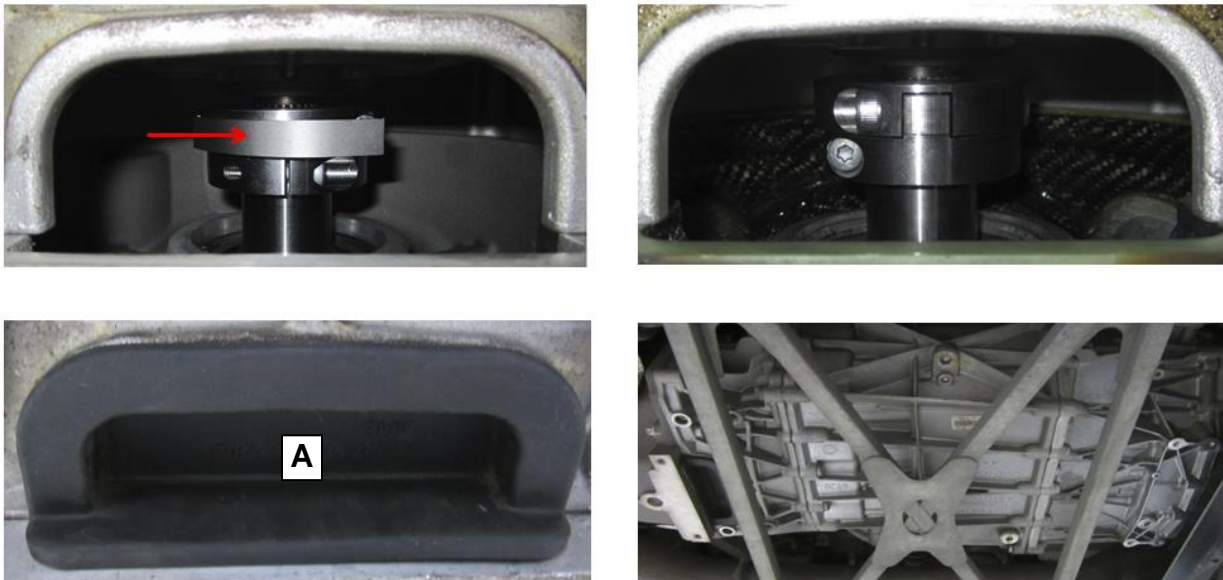
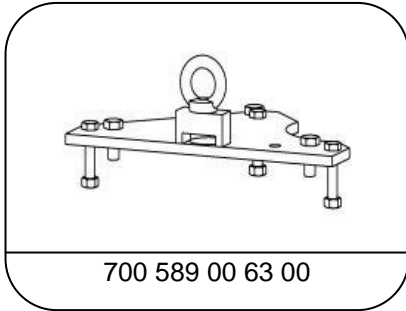

Figure 5

**i** **Note** (regarding WIS documents referenced in this Procedure):

Replacement of parts not listed in the parts table of this Procedure are not claimable under this campaign. If replacement of additional part(s) is necessary, check coverage prior to submitting under warranty.

### **i** **Special Tools**



Lifting device

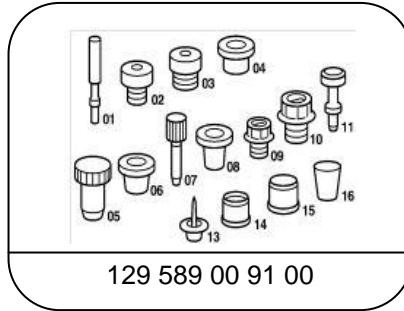

Record plugs

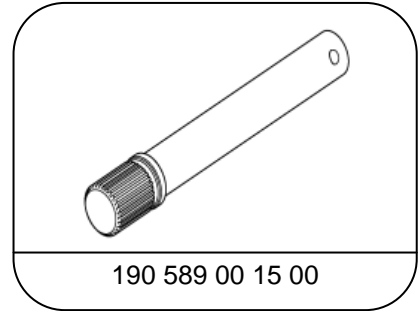

Assembly drift

### **Workshop equipment**

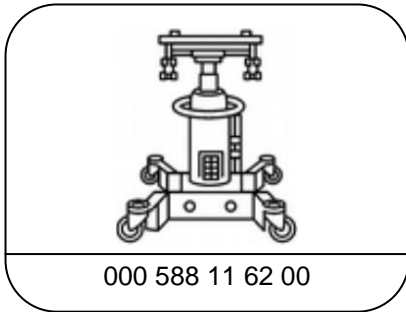

Major assembly mount

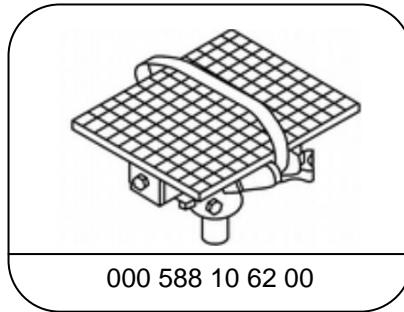

Support plate

**i** **Note:**

Required equipment as per SSEP on-line catalog

**Primary Parts Information**

Qty.	Part Name	Part Number	Estimated Replacement Rate
1	Propeller shaft (drive shaft)	A 190 410 07 00	20%
1	Screw/bolt, front propeller shaft	N000000 006551	
1	Sealing ring	A 221 492 00 81	
2	Clamp	A 000 490 15 41	
16	Hex bolt (torque tube to eng.)	N000000 006589	
2	Hex bolt (torque tube to eng.)	N910105 010044	
2	Nut (drive shaft)	N913023 010002	
2	O-ring of feed line to connecting point	A 019 997 60 45	
4	Axle shaft disk of rear axle shaft flange	A 220 357 00 42	
12	Screw/bolt, axle shaft of rear axle shaft flange	A 002 990 10 03	
6	Bolt (drive shaft flange to eng.)	N000000 000276	
1	Bolt (trans. mounting)	A190 990 00 99	
4	O-ring (oil line to trans.)	A020 997 27 45	
8	Bolt, stiffening bracket (lwr rr)	N910142 008000	
4	Nut, stiffening bracket (lwr rr)	N910112 008000	
8	(6) Bolt, cross member to frame	N000000 007063	
	(2) Bolt (rr stiffening member to body)		
5	Nut (bracket to rr stiffening member)	N000000 006037	
2	Bolt (rr stiffening member to body)	N910143 008003	
2	Nut (rr stiffening member to body)	N000000 003175	
3	Bolt, motor mount support	N910143 010017	
2	Bolt motor mount	N910105 008019	
4	Bolt, motor mount (active motor mount)	N910143 010017	
8	Bolt, exhaust pipe to bracket	N000000 000276	
2	Nut, exhaust to cross member	N000000 003175	
8	Bolt, exhaust to body	A001 990 99 00	
4	Bolt, center cross member	N000000 005053	
6	Bolt, rear cross member	N000000 005053	
6	Bolt, drive shaft	A002 990 10 03	
1	Compensating ring	A 190 411 03 00	
2	Profile clamp (exhaust head pipe)	A000 995 61 33	
2	Profile clamp	A000 995 62 33	
4	Screw/bolt	A210 990 06 04	
8	Bolt (exhaust bracket)	N000000 000276	
1 <sup>1)</sup>	Long-life grease	A 000 989 63 51 11	
1 <sup>2)</sup>	Lubricant for rubber installation	A 000 989 03 67	

<sup>1)</sup> 1 container is sufficient for at least 20 vehicles submit as local purchase GRZ00146 qty of 1, handling is included.

<sup>2)</sup> 1 container is sufficient for at least 20 vehicles submit as local purchase RBR00175 qty of 1, handling is included.

**i** **Note:**

- Please be aware that only the part number(s) referenced in the Campaign Bulletin is/are approved for use to repair the vehicle. Repairs performed using any other part(s) will not have been performed in accordance with the campaign. Accordingly, warranty claims submitted with reference to an improper part number(s) will be denied.
- The following allowable labor operation should be used when submitting a warranty claim for this repair:

**Warranty Information****Repair 1**

**Operation:** Check drive shaft (02-9506)  
Includes: Read production number

Damage Code	Operation Number	Labor Time (hrs.)
41 900 38 8	02-9506	0.2

**Repair 2**

**Operation:** Check drive shaft (02-9506)  
Includes: Read production number  
Replace drive shaft (02-9507)  
Includes: Remove/install drive shaft with housing

Damage Code	Operation Number	Labor Time (hrs.)
41 900 38 7	02-9506	0.2
	02-9507	9.6

**i** **Note**

Operation Number labor times are subject to change.