



Michael A. Berardi
Director
Service Engineering Operations
Ford Customer Service Division

Ford Motor Company
P. O. Box 1904
Dearborn, Michigan 48121

November 1, 2016

TO: All U.S. Ford and Lincoln Dealers

SUBJECT: NEW VEHICLE DEMONSTRATION / DELIVERY HOLD - Safety Recall 16S18
Certain 2014-2015 Model Year Explorer and Police Interceptor Utility Vehicles
Rear Suspension Toe Link Replacement

AFFECTED VEHICLES

Vehicle	Model Year	Assembly Plant	Build Dates
Explorer	2014-2015	Chicago	January 17, 2014 through May 31, 2014
Police Interceptor Utility	2014-2015	Chicago	January 21, 2014 through May 13, 2014

Affected vehicles are identified in OASIS and FSA VIN Lists.

REASON FOR THIS SAFETY RECALL

In some of the affected vehicles, the rear suspension toe link(s) may have poor weld quality which may cause them to fracture. A fractured rear suspension toe link may cause a loss of steering control, a difficult steering condition, or rear suspension noise. Loss of steering control increases the risk of a crash.

SERVICE ACTION

Before demonstrating or delivering any new in-stock vehicles involved in this recall, dealers are to replace both rear suspension toe links, check alignment and, if necessary, adjust rear toe. This service must be performed on all affected vehicles at no charge to the vehicle owner.

OWNER NOTIFICATION MAILING SCHEDULE

Owner letters are expected to be mailed the week of November 14, 2016. Dealers should repair any affected vehicles that arrive at their dealerships, whether or not the customer has received a letter.

PLEASE NOTE:

Federal law requires dealers to complete this recall service before a new vehicle is delivered to the buyer or lessee. Violation of this requirement by a dealer could result in a civil penalty of up to \$21,000 per vehicle. Correct all vehicles in your new vehicle inventory before delivery.

ATTACHMENTS

Attachment I: Administrative Information
Attachment II: Labor Allowances and Parts Ordering Information
Attachment III: Technical Information
Owner Notification Letter
Recall Reimbursement Plan

QUESTIONS & ASSISTANCE

For questions and assistance, contact the Special Service Support Center (SSSC) via the SSSC Web Contact Site. The SSSC Web Contact Site can be accessed through the Professional Technician Society (PTS) website using the SSSC link listed at the bottom of the OASIS VIN report screen or listed under the SSSC tab.

Sincerely,

A handwritten signature in black ink, appearing to read "Michael A. Berardi". The signature is fluid and cursive, with a prominent initial "M".

Michael A. Berardi

NEW VEHICLE DEMONSTRATION / DELIVERY HOLD - Safety Recall 16S18

Certain 2014-2015 Model Year Explorer and Police Interceptor Utility Vehicles
Rear Suspension Toe Link Replacement

OASIS ACTIVATION

OASIS was activated on April 26, 2016.

FSA VIN LISTS ACTIVATION

FSA VIN Lists have been available through <https://web.fsavinlists.dealerconnection.com> since April 26, 2016. Owner names and addresses will be available by November 25, 2016.

NOTE: Your FSA VIN Lists may contain owner names and addresses obtained from motor vehicle registration records. The use of such motor vehicle registration data for any purpose other than in connection with this recall is a violation of law in several states, provinces, and countries.

Accordingly, you must limit the use of this listing to the follow-up necessary to complete this recall.

SOLD VEHICLES

- Owners of affected vehicles will be directed to dealers for repairs.
- Immediately contact any of your affected customers whose vehicles are not on your VIN list but are identified in OASIS. Give the customer a copy of the Owner Notification Letter (when available) and schedule a service date.
- Correct other affected vehicles identified in OASIS which are brought to your dealership.
- Dealers are to prioritize repairs of customer vehicles over repairs of new and used vehicle inventory.

STOCK VEHICLES

- Correct all affected units in your new vehicle inventory before delivery.
- Use OASIS to identify any affected vehicles in your used vehicle inventory.

DEALER-OPERATED RENTAL VEHICLES

A new law prohibits a Rental Company from selling, renting or leasing vehicles subject to a safety recall. This could impact dealer-operated rental fleets of 35 vehicles or more, including FRAC, LRAC, and DDR vehicles. Please see EFC04833 for details and consult your legal counsel for legal advice.

TITLE BRANDED / SALVAGED VEHICLES

Affected title branded and salvaged vehicles are eligible for this recall.

ADDITIONAL REPAIR (LABOR TIME AND/OR PARTS)

Additional repairs identified as necessary to complete the FSA should be managed as follows:

- For vehicles within new vehicle bumper-to-bumper warranty coverage, follow existing warranty and policy guidelines for related damage claims. No SSSC approval is required for these vehicles:
 - Ford vehicles – 3 years or 36,000 miles
- For vehicles outside new vehicle bumper-to-bumper warranty coverage, submit an Approval Request to the SSSC Web Contact Site prior to completing the repair.

NEW VEHICLE DEMONSTRATION / DELIVERY HOLD - Safety Recall 16S18

Certain 2014-2015 Model Year Explorer and Police Interceptor Utility Vehicles

Rear Suspension Toe Link Replacement

OWNER REFUNDS

- **This safety recall must still be performed, even if the owner has paid for a previous repair. Claiming a refund will not close the recall on the vehicle.**
- Ford Motor Company is offering a refund for owner-paid repairs covered by this recall if the repair was performed prior to the date indicated in the reimbursement plan, which is posted with this bulletin. Owners are directed to seek reimbursement through authorized dealers or, at their option, directly through Ford Motor Company at P.O. Box 6251, Dearborn, MI 48121-6251.
- Dealers are also pre-approved to refund owner-paid emergency repairs that were performed away from an authorized servicing dealer after the end date specified in the reimbursement plan. Non-covered repairs, or those judged by Ford to be excessive, will not be reimbursed.
- Refunds will only be provided for the cost associated with rear suspension toe link replacement.

RENTAL VEHICLES

The use of rental vehicles is not approved for this program.

CLAIMS PREPARATION AND SUBMISSION

- Enter claims using Direct Warranty Entry (DWE) or One Warranty Solution (OWS).
 - DWE: refer to ACESII manual for claims preparation and submission information.
 - OWS: when entering claims in DMS software, select claim type 31: Field Service Action. The FSA number (16S18) is the sub code.
- Additional labor and/or parts must be claimed as related damage on a separate repair line from the FSA.
- Submit refunds on a separate repair line.
 - Program Code: 16S18
 - Misc. Expense: ADMIN
 - Misc. Expense: REFUND
 - Misc. Expense: 0.2 Hrs.
- Multiple refunds should be submitted on one repair line and the invoice details for each repair should be detailed in the comments section of the claim.

NEW VEHICLE DEMONSTRATION / DELIVERY HOLD - Safety Recall 16S18

Certain 2014-2015 Model Year Explorer and Police Interceptor Utility Vehicles

Rear Suspension Toe Link Replacement

LABOR ALLOWANCES

Description	Labor Operation	Labor Time
Replace both rear suspension toe links	16S18B	0.6 Hours
Check alignment and, if necessary, adjust rear toe	16S18C	0.6 Hours

PARTS REQUIREMENTS / ORDERING INFORMATION

Part Number	Description	Order Quantity
DB5Z-5A972-E	Rear Toe Link Kit – AWD and all Police Interceptor Utility vehicles	1
DB5Z-5A972-F	Rear Toe Link Kit – FWD (except Police Interceptor Utility vehicles)	1

The DOR/COR number for this recall is 51051.

Order your parts through normal order processing channels. To guarantee the shortest delivery time, an emergency order for parts must be placed.

DEALER PRICE

For latest prices, refer to DOES II.

PARTS RETENTION AND RETURN

Follow the provisions of the Warranty and Policy Manual, Section 1 - WARRANTY PARTS RETENTION AND RETURN POLICIES.

EXCESS STOCK RETURN

Excess stock returned for credit must have been purchased from Ford Customer Service Division in accordance with Policy Procedure Bulletin 4000.

CERTAIN 2014-2015 MODEL YEAR EXPLORER AND POLICE INTERCEPTOR UTILITY VEHICLES — REAR SUSPENSION TOE LINK REPLACEMENT

OVERVIEW

In some of the affected vehicles, the rear suspension toe link(s) may have poor weld quality which may cause them to fracture. A fractured rear suspension toe link may cause a loss of steering control, a difficult steering condition, or rear suspension noise. Loss of steering control increases the risk of a crash. Dealers are to replace both rear suspension toe links, check alignment and, if necessary, adjust rear toe.

SERVICE PROCEDURE

⚠ WARNING: Suspension fasteners are critical parts that affect performance of vital components and systems. Tighten fasteners as specified. Measure the distance from the center of the wheel hub to the lip of the fender with the vehicle in a level, static ground position (ride height) before disassembly. When securing the *new* toe link, it must be secured at the previously measured ride height.

⚠ WARNING: Tighten the suspension bushing fasteners with the suspension supported at ride height or with the weight of the vehicle resting on the wheels and tires, otherwise toe link and bushing damage may occur.

1. Replace both rear toe links and all fasteners. Please follow the Workshop Manual (WSM) procedures in Section 204-02.

NOTE: The toe links must be secured at ride height during replacement. See Figure 1.

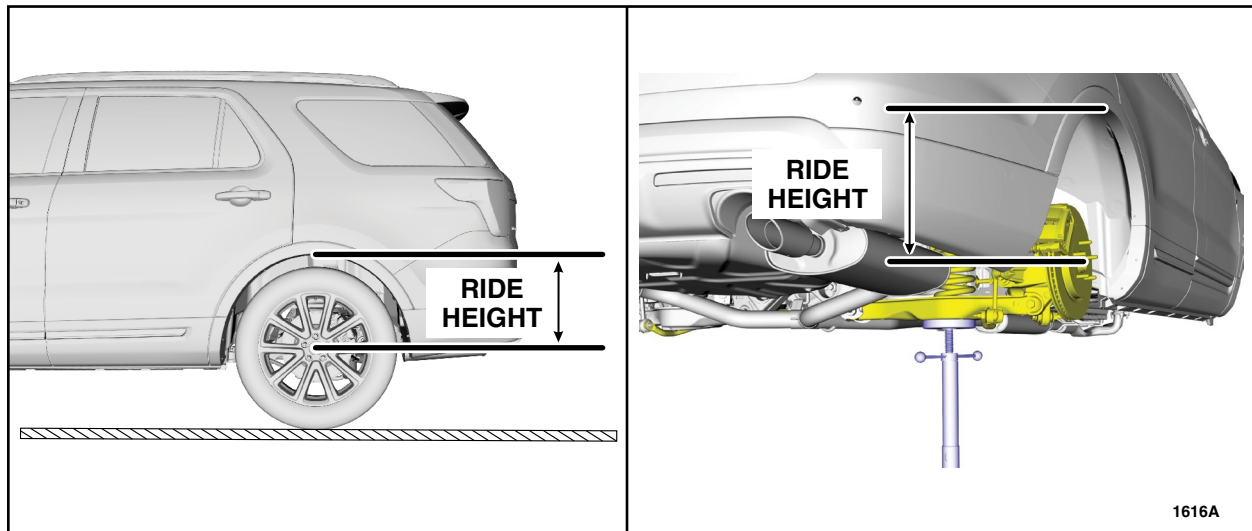

FIGURE 1



Ford Motor Company
Recall Reimbursement Plan for 16S18

Ford and Lincoln dealers are in the best position to quickly and efficiently process reimbursement requests. However, federal legislation requires all motor vehicle manufacturers to establish processes through which customers may seek recall reimbursement directly from the manufacturer or from the dealers.

Regarding the specific reimbursement plan for Recall # 16S18, owners who have paid for service to remedy the defect or noncompliance must have had that service performed prior to November 30, 2016. After this date, if repairs related to this recall are performed by a non-Ford repair facility in an emergency situation, customers must submit any refund requests through their dealership. As required by this federal regulation, Ford Motor Company submitted the details of its latest General Recall Reimbursement Plan in a letter to the National Highway Traffic Safety Administration (NHTSA) in February 2015. The following is the text of that letter and the Plan:

General Recall Reimbursement Plan
(As submitted to the NHTSA)

Pursuant to the requirements set forth in 49 CFR Part 573 and Part 577 of the Code of Federal Regulations, Ford Motor Company (Ford) is submitting required information pertaining to our general reimbursement plan for the cost of remedies paid for by vehicle owners before they are notified of a related safety recall.

Set forth below is Ford's general plan to reimburse owners and purchasers for costs incurred for remedies in advance of notification of potential safety-related defects or noncompliances pursuant to Part 573.6 (c)(8)(i). This plan has not changed since our February 20, 2015 submission.

Reimbursement Notification

Ford's notice to a vehicle owner in accordance with 49 CFR Part 577 will indicate that Ford is offering a refund if the owner paid to have service to remedy the defect or noncompliance prior to a specified ending date. In accordance with Part 573.13 (c)(2), this ending date will be defined as a minimum of ten calendar days after the date on which Ford mailed the last of its Part 577 notifications to owners, and will be indicated in the specific reimbursement plan available to owners for an individual recall. This notice will direct owners to seek eligible reimbursement through authorized dealers or, at their option, directly through Ford at the following address:

Ford Motor Company
P.O. Box 6251
Dearborn, MI 48121-6251

Ford notes that this rule allows for the identification of a beginning date for reimbursement eligibility. Under the rule, an owner who paid to remedy the defect or noncompliance prior to the identified beginning date would not be eligible for reimbursement. Ford generally has not established such a beginning date for reimbursement eligibility and does not presently anticipate changing this general policy. However, in any case where Ford determines a beginning date is appropriate, Ford will indicate that date in the owner notice. As permitted by 577.11(e), Ford may not include a reimbursement notification when all vehicles are well within the warranty period, subject to approval by the agency.

Costs to be Reimbursed

For vehicles, reimbursement will not be less than the lesser of:

- The amount paid by the owner for the remedy that specifically addressed and was reasonably necessary to correct the defect or noncompliance that is the subject of the recall, or
- The cost of parts for the remedy (to be no more than the manufacturer's list retail price for authorized part(s), plus associated labor at local labor rates, miscellaneous fees (such as disposal of waste) and taxes.

For replacement equipment, reimbursement will be the amount paid by the owner for the replacement item (limited by the amount of the retail list price of the defective or noncompliant item that was replaced, plus taxes, where the brand or model purchased by the owner was different than the brand or model that was the subject of the recall). If the item of motor vehicle equipment was repaired, the reimbursement provisions identified above for vehicles will apply.

Ford notes that costs incurred by the owner within the period during which Ford's original or extended warranty would have provided for a free repair of the problem will not be eligible for reimbursement, as provided by Part 573.13 (d)(1).

Entities Authorized to Provide Reimbursement

Ford will continue to use authorized dealers to reimburse owners under the specific reimbursement plans for a particular recall, and will encourage owners to pursue requests for reimbursement directly through dealers to expedite reimbursement. Ford will also provide a mailing address to which customers can, at their option, send requests for reimbursement directly to Ford, as previously noted. Requests for reimbursement sent directly to Ford may take up to 60 days to process. Whether the owner chooses to pursue reimbursement requests through a dealer or directly through Ford, the owner will be directed to submit the required documentation, upon which reimbursement eligibility will be determined.

Required Documentation

The reimbursement determination will depend upon the information provided by the customer. Consistent with Part 573.13 (d)(4) the following information must be submitted:

- Claimant name and address
- Vehicle make, model, and model year
- Vehicle identification number (VIN) and, for replacement equipment, a description of such equipment or, for tires, the model, size and TIN (DOT code)
- Identification of the recall number (either the Ford recall number or the NHTSA recall number)
- Identification of the owner of the recalled vehicle at the time that the pre-notification remedy was obtained
- An original receipt for the pre-notification remedy that includes a breakdown of the amount for parts, labor, other costs and taxes, including costs for the replacement item. Where the receipt covers work other than to address the recall or noncompliance, Ford may require the claimant to separately identify costs that are eligible for reimbursement.
- If the remedy was obtained during the warranty period, documentation indicating that the warranty was not honored or the warranty repair did not correct the problem related to the recall.

Failure to submit all of the above information may result in denial of the reimbursement request.

Additional Information

The Part 577 required owner notice will provide a toll-free telephone number through which specific information about the reimbursement plan can be requested from Ford. This general reimbursement plan will be incorporated into notifications pursuant to Part 573.6 by reference. Information specific to an individual recall also may be incorporated into the Part 573.6 notification.