





## **IMPORTANT SAFETY RECALL NOTICE - NHTSA CAMPAIGN NUMBER 16V051**

Dear Horse Trailer Owner:

This notice is sent to you in accordance with the requirements of the National Traffic & Motor Vehicle Safety Act.

### **REASON FOR THIS RECALL**

*Henderson Wheel & Supply* and *C&B Quality Trailer Works Inc.* have decided that a defect which relates to motor vehicle safety exists in certain 'Horse Trailer' models manufactured from 2015 to early 2016 equipped with 3500# torsion axles. The vehicles that have affected torsion axles have been improperly welded by the axle manufacturer on the torsion arm to the torsion bar/beam. As a result, the weld could break and allow the torsion arm to separate from the torsion bar/beam. A separated torsion arm could cause a wheel to separate from the trailer and strike a vehicle, a stationary object or bystander, increasing the risk of a crash causing injury and/or damage to property.

### **WHAT WE WILL DO**

The correction: Contact your C&B dealer and have them inspect the axles including welds and axle markings. Affected axles are marked with the letters **SMG**, and only those marked with those 3 letters. The correction will be made by Henderson Wheel & Supply providing replacement axles for those listed within the recall, for replacement and labor reimbursement, which will be performed free of charge to owner.

### **WHAT YOU SHOULD DO**

Please contact C&B Quality Trailer Works Inc, your C&B dealer, or Henderson Wheel and Supply as soon as possible to arrange a service date and so that necessary parts for repair can be ordered and shipped to the repair facility. Instructions for making this correction have been sent to all C&B dealers and the parts are readily available. The labor time necessary to perform this service correction is dependent upon how many axles on your unit need replaced, as well as what repair facility is doing the correction. Please ask your dealer if you wish to know how much time will be needed to schedule and process your trailer.

Your C&B Quality Trailer Works Inc. dealer is best equipped to obtain parts and provide service to ensure that your trailer is corrected as promptly as possible. If, however, you take your vehicle to your dealer on the agreed service date, and they do not remedy this condition on that date or within three (3) days, we recommend you contact C&B Quality Trailer Works Inc. customer service by calling 208-455-2768.

After Contacting your dealer and C&B customer service, if you are still not able to have the safety defect remedied without charge and within a reasonable time, you may wish to write the Administer, National Highway Traffic Safety Administration, 1200 New Jersey Ave, SE, Washington, DC 20590 or call 1-888-327-4236 (TTY: 1-800-424-9153); or go to <http://www.safercar.gov>.

Presentation of this letter to your dealer will assist in making the necessary correction in the shortest possible time. If you have sold or traded your trailer, please let us know by completing the questionnaire included and emailing it to us at [warranty@cbtrailers.com](mailto:warranty@cbtrailers.com), fax 208-459-8350, or call 1-208-455-2768.

Federal law requires any lessor who receives a notification of a determination of a safety-related defect or noncompliance pertaining to any leased motor vehicle shall send the notice to the lessee within 10 days.

If you are no longer owner of this vehicle, please provide us with any contact information so we may contact the new owners. Please call 1-208-455-2768, or email [warranty@cbtrailers.com](mailto:warranty@cbtrailers.com).

Our utmost apologies for this inconvenience. Please know that we have taken this action in the interest of your safety and continued satisfaction with our products.

# Safety Bulletin

Henderson Wheel & Trailer Supply is recalling certain 3500 lbs. capacity torsion trailer axles produced between 2/15/2015 to 9/5/2015.

The torsion arm/spindle assembly may become separated from the torsion axle inner bar.

The suspect axles are marked with the letters SMG on one side of the torsion arm (see image #1) and a blank on the other. (see image #2). To inspect these axle(s) it may be necessary to climb under the trailer or remove the tire & wheel. Both sides of the axle(s) will need to be inspected. A flashlight and mirror will be helpful with inspection of axle(s).

**Warning:** Please use extreme caution when inspecting axles.

If you are in possession of any of these axles or have any question or concerns please contact us at:

Henderson Wheel & Trailer Supply  
Salt Lake City, 801-486-4916  
Boise, 208-344-6526  
or [warranty@hendersonwheel.com](mailto:warranty@hendersonwheel.com)

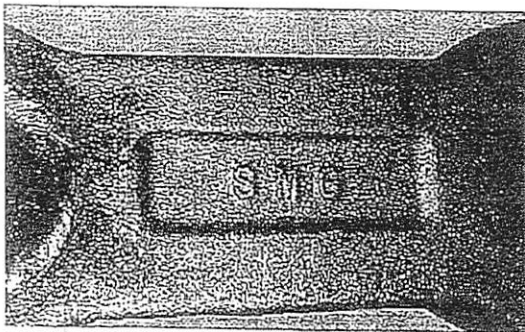

Image # 1

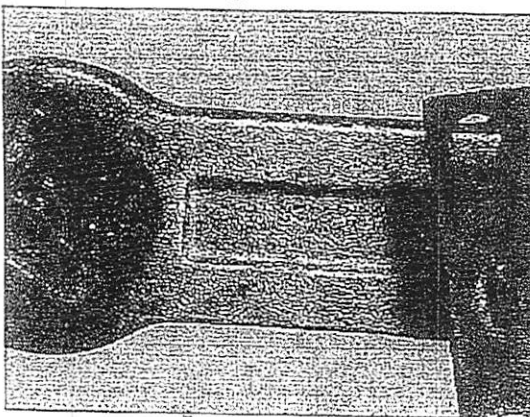
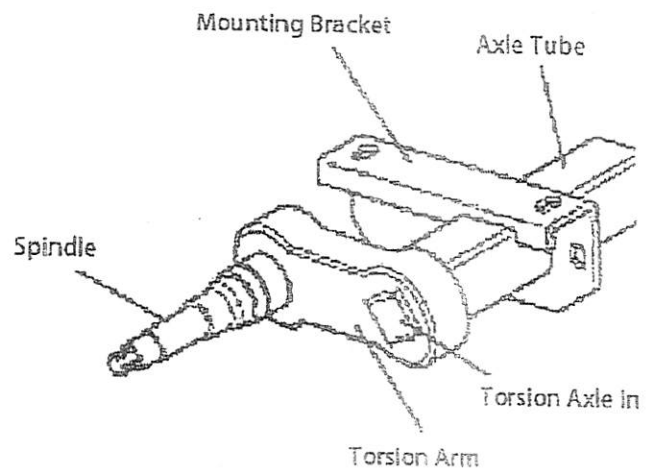

Image # 2



**Henderson**  
Wheel & Trailer Supply