

Product Safety Recall

15438 Front Passenger Air Bag Inflator



Reference Number: N15043800

Release Date: January 2017

Revision: 02

Revision Description: Releasing second segment of the involved vehicle population, which includes Georgia, Hawaii, Louisiana, Mississippi, South Carolina, Texas, Guam, Saipan, U.S. Samoa and U.S. Virgin Islands. Please discard all copies of bulletin 15438-01.

Attention: Due to limited parts availability, this safety recall is being released in segments. The mailing of recall notification letters has been staged based on the propensity of a geographic area to consistently experience high-absolute humidity. High-absolute humidity has been determined to be an underlying factor in the manifestation of the defect described below. The first segment was released on January 6, 2017 and consisted of involved vehicles currently registered or previously registered in Alabama, Florida or Puerto Rico. The second segment is being released today and consists of involved vehicles currently registered or previously registered in Georgia, Hawaii, Louisiana, Mississippi, South Carolina, Texas, Guam, Saipan, U.S. Samoa or U.S. Virgin Islands. Dealers are requested to service customer owned vehicles first and to refrain from servicing involved vehicles in their inventory, unless a bona fide sale/delivery is pending. The release of the second segment allows for the mailing of the remaining recall notification letters, which is scheduled for January 31, 2017, and the changing of involved vehicle status from "Incomplete – Remedy not yet available" to "Open" on the Investigate Vehicle History (IVH) screen in the Global Warranty Management (GWM) system.

It is a violation of Federal law for a dealer to deliver a new motor vehicle or any new or used item of motor vehicle equipment (including a tire) covered by this notification under a sale or lease until the defect or noncompliance is remedied.

All involved vehicles that are in dealer inventory must be held and not delivered to customers, dealer traded, or used for demonstration purposes until the repair contained in this bulletin has been performed on the vehicle.

Make	Model	Model Year		RPO	Description
		From	To		
Chevrolet	Silverado 2500/3500 HD	2007	2008		
GMC	Sierra 2500/3500 HD	2007	2008		

Involved vehicles are marked "open" on the Investigate Vehicle History screen in GM Global Warranty Management system. This site should always be checked to confirm vehicle involvement prior to beginning any required inspections and/or repairs.

Condition	General Motors has decided that a defect which relates to motor vehicle safety exists in all 2007-2008 model year Chevrolet Silverado and GMC Sierra 2500/3500 series heavy duty pickup trucks. Some of the front passenger air bag inflators in these vehicles may experience an alteration over time, which could lead to overaggressive combustion in the event of an air bag deployment. This condition could create excessive internal pressure when the air bag is deployed, which could result in the body of the inflator rupturing upon deployment. In the event of an inflator rupture, metal fragments could pass through the air bag cushion material, which may result in injury or death to vehicle occupants.
Correction	Dealers are to replace the front passenger air bag inflator module.

Parts

An initial supply of part number 84255088 (Front Passenger Air Bag Inflator Kit) required to complete this recall was pre-shipped to involved dealers of record located in Georgia, Hawaii, Louisiana, Mississippi, South Carolina, Texas, Guam, Saipan, U.S. Samoa and U.S. Virgin Islands. This pre-shipment began and conclude the week of January 23, 2017. Shipments covered all involved vehicles. Pre-shipped parts will be charged to dealers' open parts account.

Dealers of record located in Alabama, Florida and Puerto Rico were pre-shipped an initial supply of parts to complete this recall the week of January 3, 2017.

Additional parts, if required, are to be obtained from GMCCA. Dealers should refer to their "involved vehicles listing" before ordering parts. **Parts are currently in limited supply and dealers should order as a Customer Special Order (CSO) only and the complete 17 character Vehicle Identification Number (VIN) must be included in the note field.** Daily Replenishment Orders (DRO's) will be cancelled. **Dealers should not place orders through the Service Parts Assistance Center (SPAC);** doing so will delay shipment of the part and will not provide visibility in the order tracking system. **All orders will be reviewed prior to being filled.**

Product Safety Recall

15438 Front Passenger Air Bag Inflator



Due to flight restrictions for hazardous goods shipments, dealer orders may arrive via FedEx or with the normal Parts Distribution Center (PDC) delivery. Parts will not be shipped overnight and dealers should plan accordingly for the possibility of extended transit time.

Important: Parts may be removed from Retail Inventory Management (RIM) management. Dealers should review the affected parts to confirm RIM managed status. Parts may have quantity limiters in effect.

Quantity	Part Name	Part No.
1	Front Passenger Air Bag Inflator Kit	84255088

Important: Do not discard or destroy the box containing the new passenger air bag inflator, it will be needed to return the used inflator. The box contains special instructions for the packaging and shipment of the used inflator. The instructions must be followed without exception. **DO NOT DEPLOY ANY INFLATOR.**

Special Tools

Dealers are required to use the air bag mounting bracket, shown below, to replace the front passenger air bag inflator module. These brackets were previously provided to dealers by General Motors through Bosch Automotive Service Solutions. The Bosch tool number is EL-51377. If your dealership does not have the air bag mounting bracket, do not attempt to perform this service procedure and immediately contact charles.berecz@gm.com for assistance. Attempting to replace the front passenger air bag inflator module without using the bracket poses a safety risk for the technician and anyone else in the area.

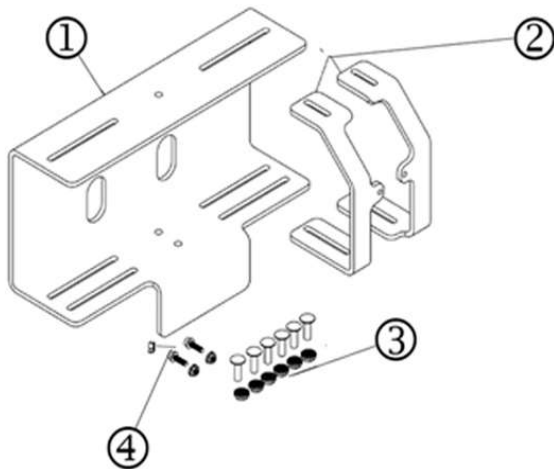

4006668

(1) Mounting Bracket (2) Support Bars (3) Support Bar Hardware (4) Air bag Mounting Hardware.

Warranty Information

Labor Operation	Description	Labor Time	Trans. Type	Net Item
9101563	Replace Front Passenger Air Bag Inflator Module Add: SLT Trim Level – GMC Only	0.9* 0.1	ZFAT	N/A

* Includes 0.2 hour administrative allowance for return of the used inflator (document preparation and packaging).

Service Procedure

Note: Dealers are required to use the air bag mounting bracket to perform the front passenger air bag inflator module replacement procedure. If the air bag mounting bracket is not available, do not proceed with this repair.

Warning: Do not deploy or discard the air bag inflator module.

Remove the instrument panel passenger air bag assembly from the vehicle. Refer to *Air bag Instrument Panel Module Replacement* in SI.

Product Safety Recall

15438 Front Passenger Air Bag Inflator



SAFETY PRECAUTIONS

Warning: If an air bag system is not handled using proper procedures and methods, it may be activated accidentally during work resulting in a life-threatening serious accident. If the service procedure is NOT performed correctly, the system may fail to activate when needed. Be sure to perform the proper work safely and according to the instructions in this service procedure.

1. Eliminate Static Electricity. Before start of work, touch a metallic portion of the vehicle with a bare hand to discharge static electricity charged on your body.
2. DO NOT Measure Resistance. DO NOT measure resistance of air bag components. Measuring current of a circuit tester may cause accidental activation.
3. Handle the air bag properly. If an inflator is dropped, replace it with a NEW inflator.
4. DO NOT allow foreign objects near the air bag. Collect and account for all removed nuts/bolts to prevent them from landing in the air bag assembly. Any foreign objects in the air bag assembly may cause damage or injury if the air bag is activated.
5. Wear protective equipment. Always wear appropriate protective equipment when working on the air bag.

FRONT PASSENGER AIR BAG INFLATOR MODULE REPLACEMENT

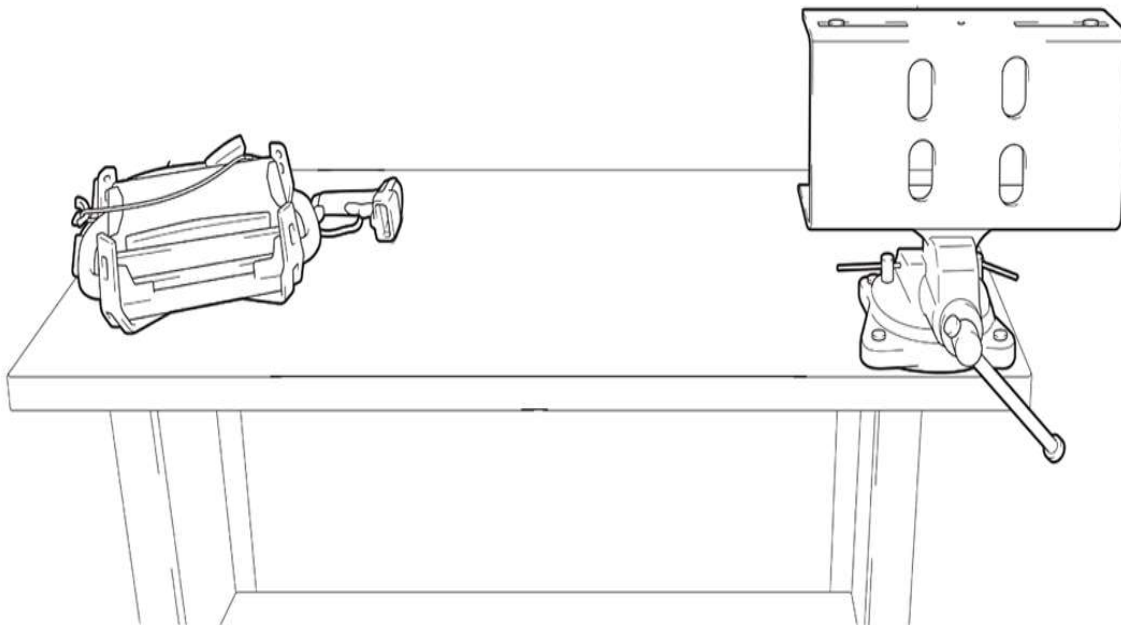

3607819

Danger: To avoid personal injury or death, it is critical to use an air bag module bracket when replacing an inflator module. Carefully read and follow the instructions below:

1. Confirm the bracket assembly is installed securely in the vice.
2. Confirm there are no loose objects or people exposed to the back side of the bracket for safety in the unlikely event of air bag deployment due to improper work procedures. The air bag is NOT being replaced due to an inadvertent deployment concern.
3. Confirm that no objects, tools or people are within 3 feet (1 meter) of the back side of the bracket.
4. Confirm that no objects, tools or people are within 2 feet (0.6 meters) of the sides of the bracket.

Product Safety Recall

15438 Front Passenger Air Bag Inflator



5. **BEFORE** starting work and periodically while working on the air bag module, touch a metallic part of the work bench to discharge static electricity in the body.

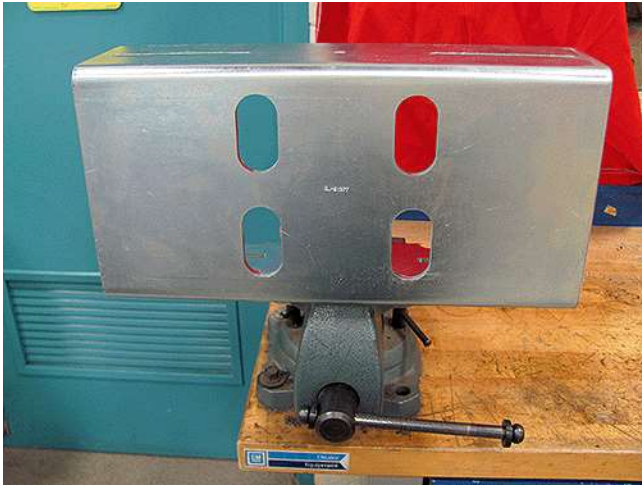

4664047

1. Mount the air bag module bracket securely in a vice.



4664048

2. Using the hardware kit supplied with the module bracket, loosely mount the airbag assembly to the bracket using two nuts and bolts.

Product Safety Recall

15438 Front Passenger Air Bag Inflator

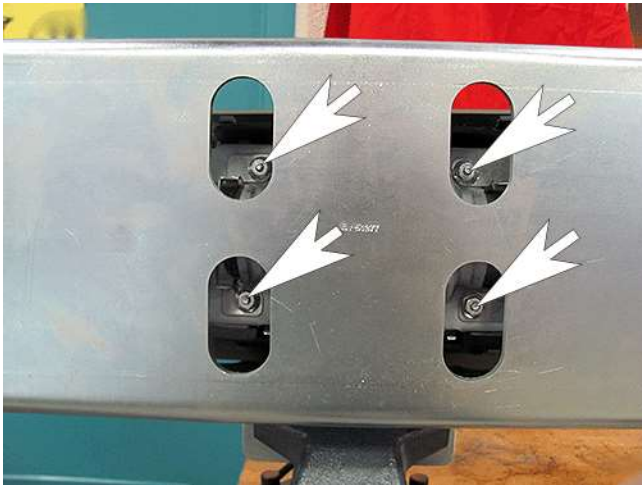

4664049

3. Position the air bag so that all four stopper plate nuts can be removed through the access holes.



4664050

4. Tighten the two fasteners that attach the airbag to the module bracket.
5. Confirm the following steps have been completed BEFORE proceeding to the next step:
 - The mounting bracket is secure in the vise.
 - The air bag module is secured to the bracket.

Product Safety Recall

15438 Front Passenger Air Bag Inflator



3607909

Danger: To avoid personal injury, *ALWAYS* keep as much of your body as possible in front of the bracket when working on the air bag assembly. Remember to periodically touch a metallic part of the vehicle or work bench to discharge static electricity in the body. **DO NOT** use power tools when performing the inflator removal/reinstallation steps.

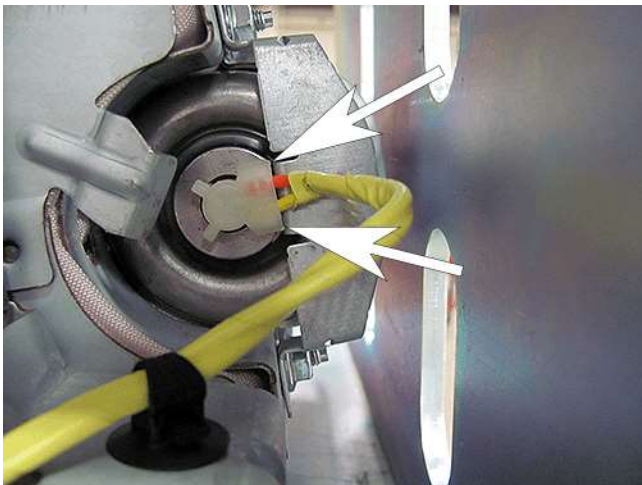

4664051

6. Note the orientation between the inflator and the stopper plate.

Product Safety Recall

15438 Front Passenger Air Bag Inflator



4664052

7. Use the access holes in the bracket to loosen and remove the four self-locking nuts. Discard the nuts, they will not be reused.
8. Remove the two stopper plates.



4664053

9. Disengage the wire harness locator from the housing.

Product Safety Recall

15438 Front Passenger Air Bag Inflator

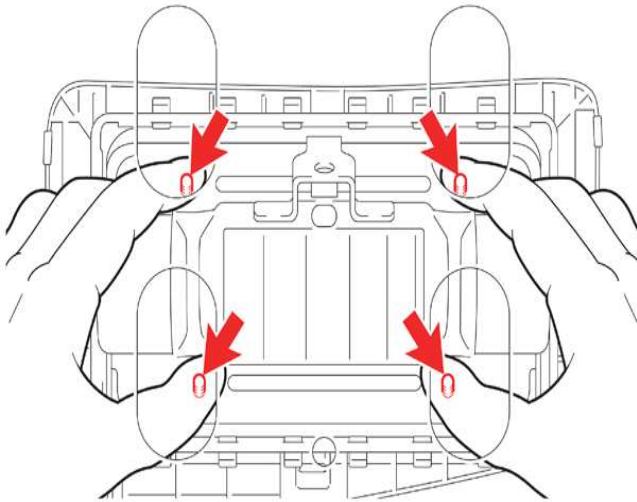

3607857

10. Gently push in the 4 studs to loosen the inflator for removal.



4664060

11. Remove the inflator from the housing, slide the inflator away from the harness side.



4664063

Product Safety Recall

15438 Front Passenger Air Bag Inflator



12. Put a mark on the removed inflator and store it in the provided replacement part box. Refer to the packaging instructions that were included with the new inflator module kit.



4664074

13. Record the serial number from the service inflator kit on the repair order.



4664064

14. Carefully slide the new inflator into the air bag assembly. Ensure the inflator is installed with the harness end first.

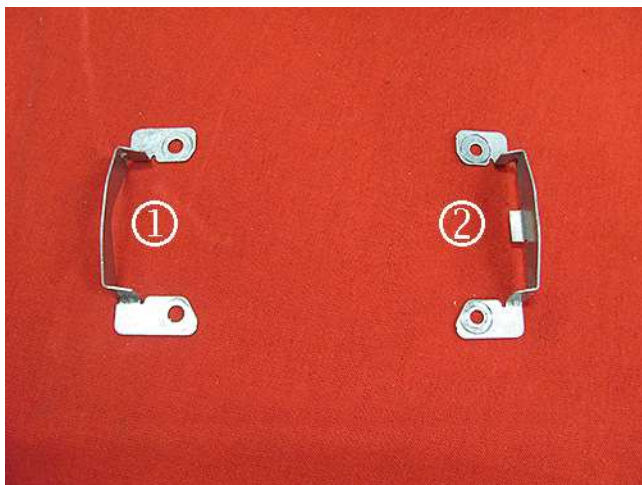

4664065

Product Safety Recall

15438 Front Passenger Air Bag Inflator



- 15. Confirm the identification of the stopper and the position determining plate. *THEY ARE DIFFERENT.* Refer to the illustration: (1) Stopper Plate (2) Position Determining Plate.
- 16. The Position determining Plate goes on the harness end, the Stopper Plate goes on the opposite end.
- 17. Loosely install the two plates using the 4 new nuts supplied with the inflator kit, **DO NOT TIGHTEN.**

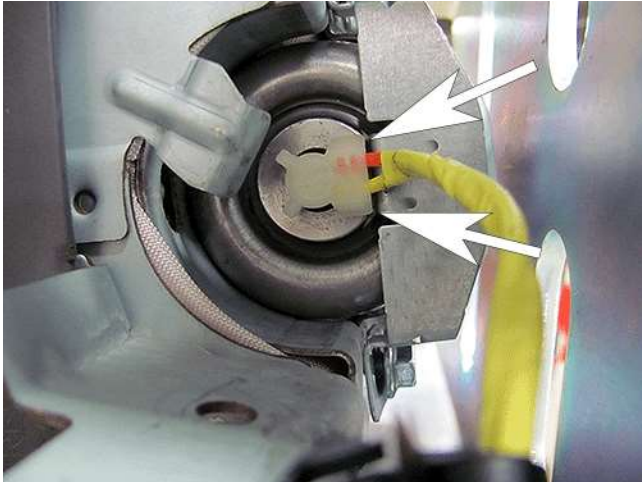

4664068

- 18. Rotate the inflator until the harness connector aligns with the Position Orientating Plate.

Warning: *DO NOT* pinch the harness between the inflator and the Position Orientating Plate.

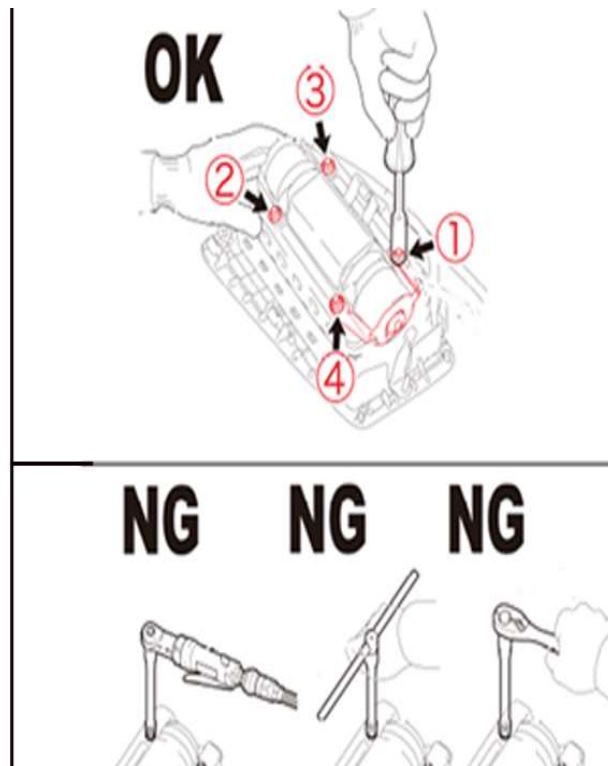
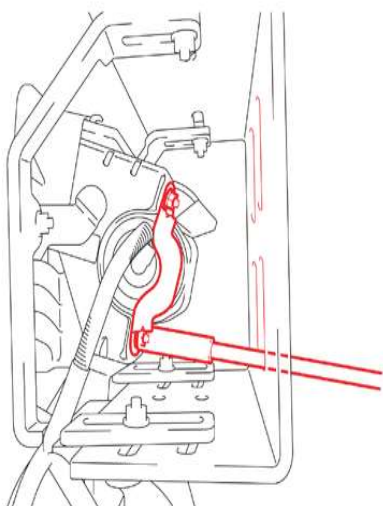

3610416

Product Safety Recall 15438 Front Passenger Air Bag Inflator



19. Tighten four (4) *NEW* plate nuts evenly in several increments in the order shown in the illustration using a 10 mm socket driver while pushing the inflator. You will encounter some resistance during tightening because these nuts are self-locking nuts. **Torque Specification: 6.5 Nm (57.53 in-lb)**

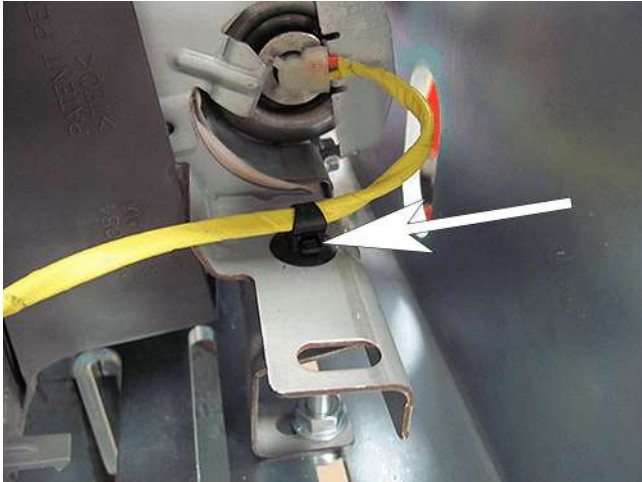

4664069

20. *Install the wire harness locator to the housing.*
21. Remove the air bag assembly from the bracket by removing the two bolts and the air bag assembly.

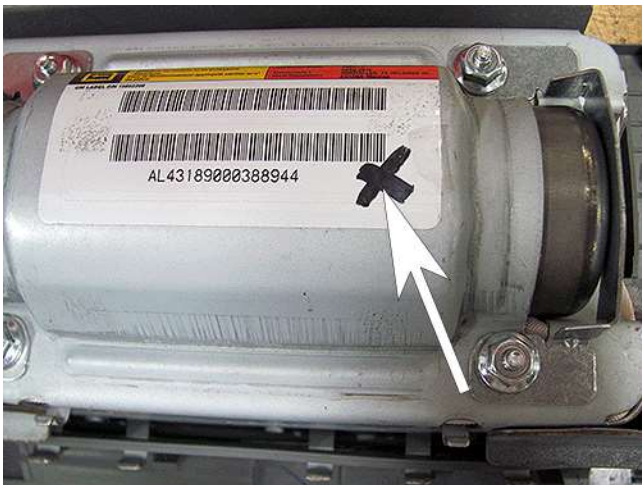

4664070

22. Mark the air bag module with an X at the right side of the ID tag.
23. Reinstall the instrument panel passenger air bag assembly. Refer to *Air bag Instrument Panel Module Replacement* in SI.
24. The box that the new passenger air bag inflator was shipped in must be utilized to return the used inflator. The box contains special instructions for the packaging and shipment of the used inflator. The instructions must be followed without exception. If the original box is not available or you have questions about the special shipping instructions, please contact your District Service Manager- Aftersales for assistance. **DO NOT DEPLOY ANY INFLATOR.**

Dealer Responsibility – For USA & Export (USA States, Territories, and Possessions)

It is a violation of Federal law for a dealer to deliver a new motor vehicle or any new or used item of motor vehicle equipment (including a tire) covered by this notification under a sale or lease until the defect or noncompliance is remedied.

Product Safety Recall

15438 Front Passenger Air Bag Inflator



The US National Traffic and Motor Vehicle Safety Act provides that each vehicle that is subject to a recall of this type must be adequately repaired within a reasonable time after the customer has tendered it for repair. A failure to repair within sixty days after tender of a vehicle is prima facie evidence of failure to repair within a reasonable time. If the condition is not adequately repaired within a reasonable time, the customer may be entitled to an identical or reasonably equivalent vehicle at no charge or to a refund of the purchase price less a reasonable allowance for depreciation. To avoid having to provide these burdensome remedies, every effort must be made to promptly schedule an appointment with each customer and to repair their vehicle as soon as possible. In the recall notification letters, customers are told how to contact the US National Highway Traffic Safety Administration if the recall is not completed within a reasonable time.

Dealer Responsibility – All

All new, used, GM Certified Used, courtesy transportation vehicles, dealer shuttle vehicles, etc. in dealers' possession and subject to this recall must be held and inspected/repared per the service procedure of this bulletin before customers take possession of these vehicles. Involved vehicles must be held and not delivered to customers, dealer-traded, released to auction, used for demonstration, or any other purpose.

All GM Certified Used vehicles currently in the dealers' inventory within the Certified Pre-Owned Inventory System (CPOIS) will be de-certified and must be held and remedied per the service procedure in this bulletin. Upon submitting an accepted/paid warranty transaction in the Global Warranty Management (GWM) system, the vehicle can be re-certified for sale within the CPOIS system, or once again be used in the CTP program.

Dealers are to service all vehicles subject to this recall at no charge to customers, regardless of mileage, age of vehicle, or ownership, from this time forward.

Customers who have recently purchased vehicles sold from your vehicle inventory, and for which there is no customer information indicated on the dealer listing, are to be contacted by the dealer. Arrangements are to be made to make the required correction according to the instructions contained in this bulletin. A copy of the customer letter is provided in this bulletin for your use in contacting customers. Recall follow-up cards should not be used for this purpose, since the customer may not as yet have received the notification letter.

In summary, whenever a vehicle subject to this recall enters your vehicle inventory, or is in your dealership for service in the future, you must take the steps necessary to be sure the recall correction has been made before selling or releasing the vehicle.

Dealer Reports

For dealers with involved vehicles, a listing with involved vehicles has been prepared and will be provided to U.S. and Canadian dealers through the GM GlobalConnect Recall Reports, or sent directly to export dealers. The listing may contain customer names and addresses obtained from Motor Vehicle Registration Records. The use of such motor vehicle registration data for any purpose other than follow-up necessary to complete this recall is a violation of law in several states/provinces/countries. Accordingly, you are urged to limit the use of this report to the follow-up necessary to complete this recall.

Customer Notification

USA & Canada - General Motors will notify customers of this recall on their vehicle (see copy of customer letter included with this bulletin).

Export - Letters will be sent to known owners of record located within areas covered by the U.S. National Traffic and Motor Vehicle Safety Act. For owners outside these areas, dealers should notify customers using the attached sample letter.

GM bulletins are intended for use by professional technicians, NOT a "do-it-yourselfer". They are written to inform these technicians of conditions that may occur on some vehicles, or to provide information that could assist in the proper service of a vehicle. Properly trained technicians have the tools, equipment, safety instructions, and know-how to do a job properly and safely. If a condition is described, DO NOT assume that the bulletin applies to your vehicle, or that your vehicle will have that condition. See your dealer for information on whether your vehicle may benefit from the information.



**We Support
Voluntary Technician
Certification**



IMPORTANT SAFETY RECALL

This notice applies to your vehicle, **VIN:** _____

Dear General Motors Customer:

This notice is sent to you in accordance with the National Traffic and Motor Vehicle Safety Act.

General Motors has decided that a defect, which relates to motor vehicle safety, exists in all 2007-2008 model year Chevrolet Silverado and GMC Sierra 2500/3500 series heavy duty pickup trucks. As a result, GM is conducting a safety recall. We apologize for this inconvenience. However, we are concerned about your safety and continued satisfaction with our products.

IMPORTANT

- Your vehicle is involved in GM safety recall 15438.
- Schedule an appointment with your GM dealer.
- This service will be performed for you at **no charge**.

Why is your vehicle being recalled?

Some of the front passenger air bag inflators in these vehicles may experience an alteration over time, which could lead to overaggressive combustion in the event of an air bag deployment. This condition could create excessive internal pressure when the air bag is deployed, which could result in the body of the inflator rupturing upon deployment. In the event of an inflator rupture, metal fragments could pass through the air bag cushion material, which may result in injury or death to vehicle occupants.

What will we do?

Your GM dealer will replace the front passenger air bag inflator module. This service will be performed for you at **no charge**. Because of service scheduling requirements, it is likely that your dealer will need your vehicle longer than the actual service correction time of approximately 60 minutes.

What should you do?

You should contact your GM dealer to arrange a service appointment as soon as possible.

Do you have questions?

If you have questions or concerns that your dealer is unable to resolve, please contact the appropriate Customer Assistance Center at the number listed below.

Division	Number	Text Telephones (TTY)
Chevrolet	1-800-630-2438	1-800-833-2438
GMC	1-866-996-9463	1-800-462-8583
Puerto Rico – English	1-800-496-9992	
Puerto Rico – Español	1-800-496-9993	
Virgin Islands	1-800-496-9994	

If after contacting your dealer and the Customer Assistance Center, you are still not satisfied we have done our best to remedy this condition without charge and within a reasonable time, you may wish to write the Administrator, National Highway Traffic Safety Administration, 1200 New Jersey Avenue, SE, Washington, DC 20590, or call the toll-free Vehicle Safety Hotline at 1.888.327.4236 (TTY 1.800.424.9153), or go to <http://www.safercar.gov>. The National Highway Traffic Safety Administration Campaign ID Number for this recall is 15V324.

Federal regulation requires that any vehicle lessor receiving this recall notice must forward a copy of this notice to the lessee within ten days.

Jeffrey M. Boyer
Vice President
Global Vehicle Safety