



RCL-15-002 Panigale Ohlins TTX Shock  
 Models: 1199 Panigale S Model Year 2014 (CAL and CDN versions)  
 1199 Panigale R Model Year 2014 (CAL and CDN versions)  
 1199 Superleggera Model Year 2014 (CAL and CDN versions)

## Recall Bulletin RCL-15-002

Date: June 8, 2015  
 To: Dealer Principal, General Manager, Service Manager, North American Dealer Network  
 From: Richard Kenton, Technical Director; Jonathan LaForte, Technical Manager

**Important:** All Dealer Principals, Service Managers, and Parts Managers should read and initial this notice.

Dear Service Manager, this notice is sent to you in accordance with the requirements of the National Traffic and Motor Vehicle Safety Act.

NHTSA Campaign I.D. Number: 15V268  
 Transport Canada Safety Recall I.D. Number: 2015-186

### Situation:

Due to a potential production fault of the Öhlins TTX rear shock absorber installed on the above-mentioned models, it is necessary to inspect, and update if needed, such component. During assembly of the rear shock, the piston nut may not have been correctly torqued; and it could loosen allowing the piston to become unsecured. This condition could lead to a rear suspension malfunction resulting in compression and rebound damping failure, possibly affecting the performance of the rear shock, and potentially causing a dangerous riding condition.

The supplier has informed Ducati that the below non-conforming lots could be affected by this fault; therefore it is necessary to check the lot number present on the shock absorber and if found to be one of those listed in the table below, update the component.

<i>NON-conforming lots - Öhlins TTX rear shock absorbers</i>					
<i>Part no.36521031A (DU 925) 1199 Panigale S/R MY14</i>			<i>Part no.36521321A (DU 935) 1199 Superleggera MY14</i>		
135860	135947	135974	135948	135975	136100
136099	136506	136507	136684	136685	136811
136681	136809	136904	136316	136462	136683
137048	137276	137869	137007	139810	
138238	138487				









Öhlins TTX rear shock absorbers NON-conforming lots are also available on the Öhlins website:  
<http://www.ohlins.com/recall/motorcycle-originally-equipped-ttx-shock-absorber/>

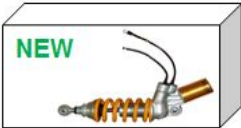

RCL-15-002 Panigale Ohlins TTX Shock  
 Models: 1199 Panigale S Model Year 2014 (CAL and CDN versions)  
 1199 Panigale R Model Year 2014 (CAL and CDN versions)  
 1199 Superleggera Model Year 2014 (CAL and CDN versions)  
**Recall Bulletin RCL-15-002**

Differing repair solutions are required depending on the model of the affected motorcycle:

1199 Panigale S/R Model Year 2014	1199 Superleggera
	
<ul style="list-style-type: none"> <li>The shock absorber must be <b>REPLACED</b>.</li> <li>Order a new shock absorber from Ducati spare part warehouse and install it on the motorcycle.</li> <li>The NON-conforming shock absorber must be sent to the Öhlins Repair Center.</li> </ul>	<ul style="list-style-type: none"> <li>The shock absorber must be <b>UPDATED</b>.</li> <li>Send the NON-conforming shock absorber to Öhlins Repair Center.</li> <li>The Öhlins Repair Center will repair the shock absorber and return it to the dealer.</li> </ul>
<p>① The dealer order a new shock absorber from Ducati spare parts warehouse and install it on the motorcycle</p>  <p style="text-align: center;"><b>DUCATI SERVICE Dealer</b></p> <p>② The dealer sends the NON-conforming Ohlins TTX shock absorber to Ohlins Repair Center</p>  <p style="text-align: center;"><b>ÖHLINS Repair Centre</b></p>	<p>① The dealer sends the NON-conforming Ohlins TTX shock absorber to Ohlins Repair Centre</p>  <p style="text-align: center;"><b>DUCATI SERVICE Dealer</b>      <b>ÖHLINS Repair Centre</b></p> <p>② Ohlins Repair Centre sends the repaired Ohlins TTX shock absorber to dealer</p> 



RCL-15-002 Panigale Ohlins TTX Shock  
Models: 1199 Panigale S Model Year 2014 (CAL and CDN versions)  
1199 Panigale R Model Year 2014 (CAL and CDN versions)  
1199 Superleggera Model Year 2014 (CAL and CDN versions)

## Recall Bulletin RCL-15-002

### Detailed procedure for model: 1199 Superleggera



#### ***1199 Superleggera shock absorber must be REPAIRED***

- 1) Identify the shock absorber lot number. If it belongs to the list of NON-conforming lots, it is necessary to have the component repaired at the Öhlins Repair Center.
- 2) Contact UPS for the collection of the NON-conforming shock absorber using the shipping account number ***UPS E9W073***.
- 3) Remove the NON-conforming shock absorber from the motorcycle.
- 4) Pack the shock absorber in such a way that no damage will occur during transport. Mark the package with "Ducati Recall Repair – DU935 – 1199 Superleggera".
- 5) Each shock absorber must be shipped with the completed ***ÖHLINS WORK ORDER FORM***. Fill out the form completely and include it in the return package. Make sure to add the VIN number so that the shock absorber is returned to the correct bike, as well as the component return address.
- 6) Ship the shock absorber to Öhlins USA or Mexico at the address below, via ***UPS NEXT DAY AIR SERVICE***. The shock absorber will be repaired and returned to the address indicated in the ÖHLINS WORK ORDER FORM.

***For USA and Canada:***

***Öhlins USA  
703 S. Grove St - Suite "C"  
Hendersonville, N.C. 28792  
1-800-336-9029, Ext. 309***

***For Mexico:***

***Moto Chavane  
Contact: Xavier Chavane  
Guadalajara  
[motochavane@hotmail.com](mailto:motochavane@hotmail.com)  
+52 33 31228564  
+52 33 36475825***



RCL-15-002 Panigale Ohlins TTX Shock  
Models: 1199 Panigale S Model Year 2014 (CAL and CDN versions)  
1199 Panigale R Model Year 2014 (CAL and CDN versions)  
1199 Superleggera Model Year 2014 (CAL and CDN versions)  
Recall Bulletin RCL-15-002

- 7) Refit the repaired shock absorber on the motorcycle.
- 8) Any shock absorber repaired at Öhlins repair centers will be identified by a punch mark next to the lot number.

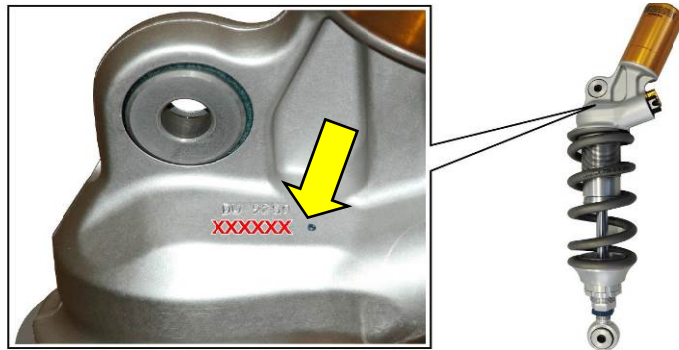

**Detailed procedure for models: 1199 Panigale S/R Model Year 2014**



***The shock absorber must be REPLACED ONLY***

- 1) Identify the shock absorber lot number; if found on the list of NON-conforming lots, order a new rear shock absorber: Part no.36521031A from Ducati through the NDCS.
- 2) The NON-conforming shock absorber installed on the motorcycle must be replaced with the new one.
- 3) Use the same package for the new shock absorber to ship the NON-conforming one to Öhlins Repair Center, via **UPS GROUND SERVICE**.
- 4) Fill out the ***DUCATI PART RETURN FORM*** completely and include it in the return package.



RCL-15-002 Panigale Ohlins TTX Shock  
 Models: 1199 Panigale S Model Year 2014 (CAL and CDN versions)  
 1199 Panigale R Model Year 2014 (CAL and CDN versions)  
 1199 Superleggera Model Year 2014 (CAL and CDN versions)

**Recall Bulletin RCL-15-002**

Ensure you add the VIN number.

<p><b><u>For USA and Canada:</u></b>  <b>Öhlins USA</b>  <b>703 S. Grove St - Suite "C"</b>  <b>Hendersonville, N.C. 28792</b>  <b>1-800-336-9029, Ext. 309</b></p>	<p><b><u>For Mexico:</u></b>  <b>Moto Chavane</b>  <b>Contact: Xavier Chavane</b>  <b>Guadalajara</b>  <a href="mailto:motochavane@hotmail.com"><b><u>motochavane@hotmail.com</u></b></a>  <b>+52 33 31228564</b>  <b>+52 33 36475825</b></p>
---	---

***Affected VIN range requiring application of the technical solution:***

You can find the affected VIN numbers in DCS. VIN numbers included in the ranges specified in the table below refer to the first and last bike involved, identified by country version: however, not all bikes included in such ranges need to undergo the updating procedure since some of them have already been updated by DMH before shipment.

<b>INVOLVED BIKES VIN NUMBER RANGES</b>			
<b>COUNTRY VERSION/MODEL</b>		<b>FROM VIN NO.</b>	<b>TO VIN NO.</b>
CAL	1199 Panigale S/R MY2014	ZDM14BPW7EB017912	ZDM14BPW8EB022746
	1199 Superleggera MY2014	ZDM14BVW8EB018439	ZDM14BVW6EB024269
CDN	1199 Panigale S/R MY2014	ZDM14BPW3EB019219	ZDM14BPW4EB019939
	1199 Superleggera MY2014	ZDM14BVW7EB021123	ZDM14BVW4EB023654

***Criteria for application of the technical solution on circulating motorcycles:***

For the designated frame numbers in the attached VIN list the motorcycles must be inspected and the shock replaced or repaired only if needed.

***Customer notification:***

Ducati North America, Inc. will notify all known owners of affected vehicles directly by First Class mail. A sample copy of the owner notification letter is enclosed for your information.

***Vehicle allocation:***

See attached Affected VIN List



RCL-15-002 Panigale Ohlins TTX Shock  
Models: 1199 Panigale S Model Year 2014 (CAL and CDN versions)  
1199 Panigale R Model Year 2014 (CAL and CDN versions)  
1199 Superleggera Model Year 2014 (CAL and CDN versions)

## Recall Bulletin RCL-15-002

### **Limitation on sale or lease of certain vehicles:**

Section 154(d) of National traffic and Motor Vehicle Safety Act of 1996 mandates that dealers correct, prior to sale or lease, any vehicle which contains a defect relating to motor vehicle safety. It is therefore mandatory that any vehicle in your inventory affected by this recall be corrected prior to sale or lease.

Replacement parts will not be auto-shipped. All dealers will need to order the parts required to update all units already in service.

### **Service Solution:**

Before replacing Öhlins TTX rear shock absorber, it is necessary to ensure that the lot number marked on it is included in the previously indicated list of NON-conforming lots.



#### **NOTE**

In order to facilitate the identification code reading, it is recommended that technicians use a mirror of appropriate size.



- 1) Remove the rider seat (See Sect.05 "Fairing" of the Workshop Manual) and lift motorcycle rear end by means of a belt secured to rear sub-frame as shown in the figure, until partially lifting the tire.





RCL-15-002 Panigale Ohlins TTX Shock  
Models: 1199 Panigale S Model Year 2014 (CAL and CDN versions)  
1199 Panigale R Model Year 2014 (CAL and CDN versions)  
1199 Superleggera Model Year 2014 (CAL and CDN versions)  
Recall Bulletin RCL-15-002

----- FUEL TANK LIFTING - 1199 SUPERLEGGERA EXCLUDED -----

- 2) Remove the **2 special nuts (1)** and the **2 screws (2)** fastening the **ignition switch cover (A)** and slide it out.

Remove the **2 nuts (3)** and the **2 screws (4)** fastening the **tank upper bracket (A)** and slide it out.

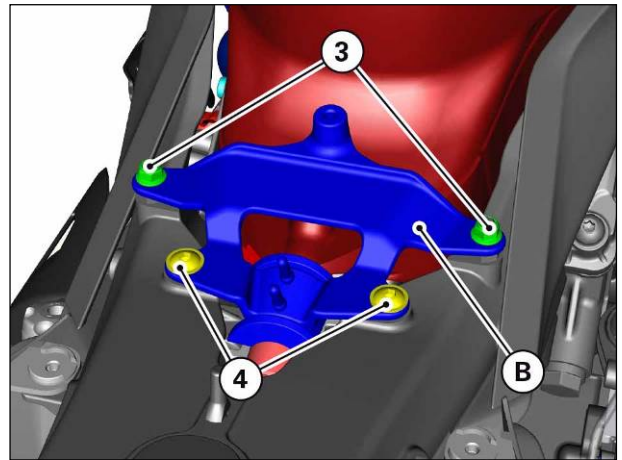
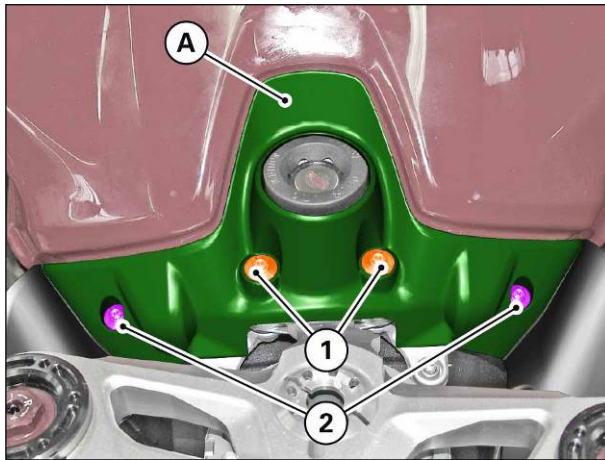

- 3) Slightly lift **fuel tank (C)** and keep it in this position with a **shim (D)**.

Remove the **2 threaded stud bolts (5)**.

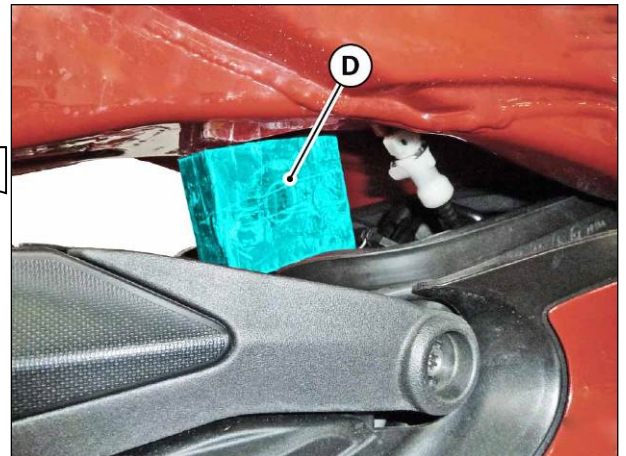
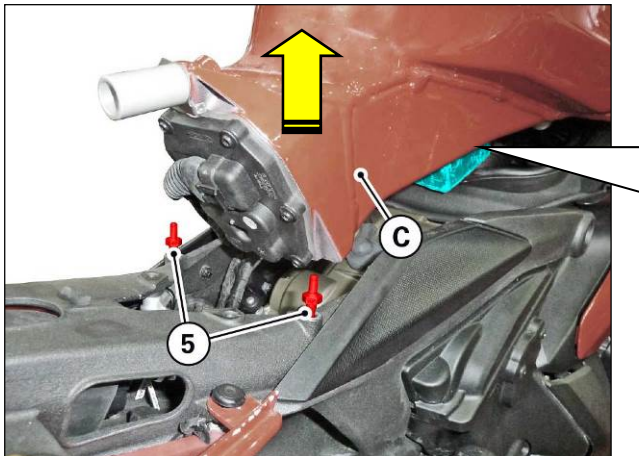



RCL-15-002 Panigale Ohlins TTX Shock  
Models: 1199 Panigale S Model Year 2014 (CAL and CDN versions)  
1199 Panigale R Model Year 2014 (CAL and CDN versions)  
1199 Superleggera Model Year 2014 (CAL and CDN versions)  
Recall Bulletin RCL-15-002

- 4) Remove **clamp (6)** and slide **tank lower bracket (E)** out.

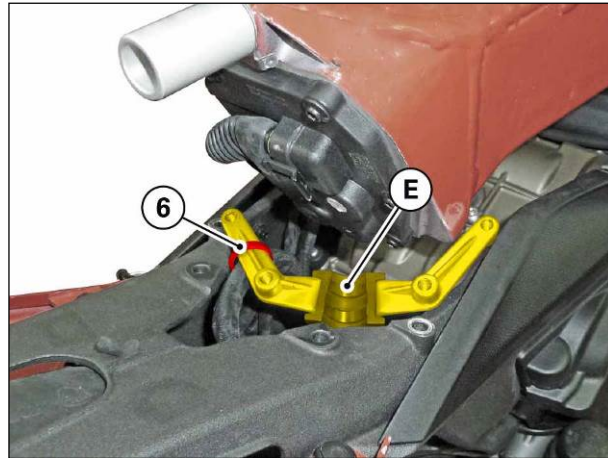

- 5) Disconnect **connectors (F)** and **(G)** of rear shock absorber stepper motor cables.



- 6) Remove **cover (H)** pulling it out from the upper edge and shifting it upwards.







## RCL-15-002 Panigale Ohlins TTX Shock

Models: 1199 Panigale S Model Year 2014 (CAL and CDN versions)

1199 Panigale R Model Year 2014 (CAL and CDN versions)

1199 Superleggera Model Year 2014 (CAL and CDN versions)

## Recall Bulletin RCL-15-002

- 7) Remove *rear screw (7)* and *front screw (7)* with the associated *spacer (8)* and remove *rear shock absorber (1)*.

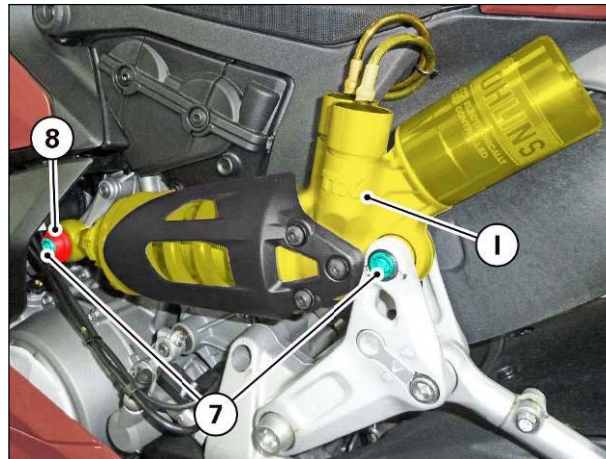

### NOTE

After removal of the shock from the motorcycle, if you have to move it awaiting to receive the updated unit from the Öhlins Repair Center, a "dummy" shock can be fashioned from a piece of bar stock and installed as shown below:

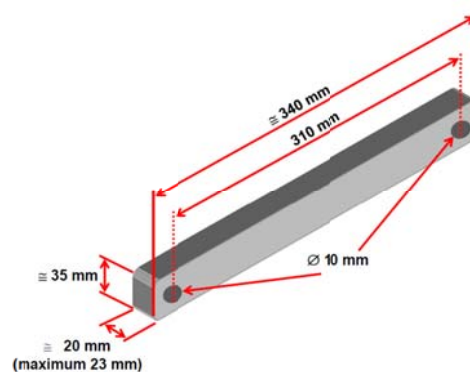



RCL-15-002 Panigale Ohlins TTX Shock

Models: 1199 Panigale S Model Year 2014 (CAL and CDN versions)

1199 Panigale R Model Year 2014 (CAL and CDN versions)

1199 Superleggera Model Year 2014 (CAL and CDN versions)

Recall Bulletin RCL-15-002

- 8) Take the new rear shock absorber and install **rear shock absorber cover (L)** tightening the **3 screws (9)** with the relevant **spacers with collar (10)** to a torque of  **$6 \text{ Nm} \pm 10\%$** .

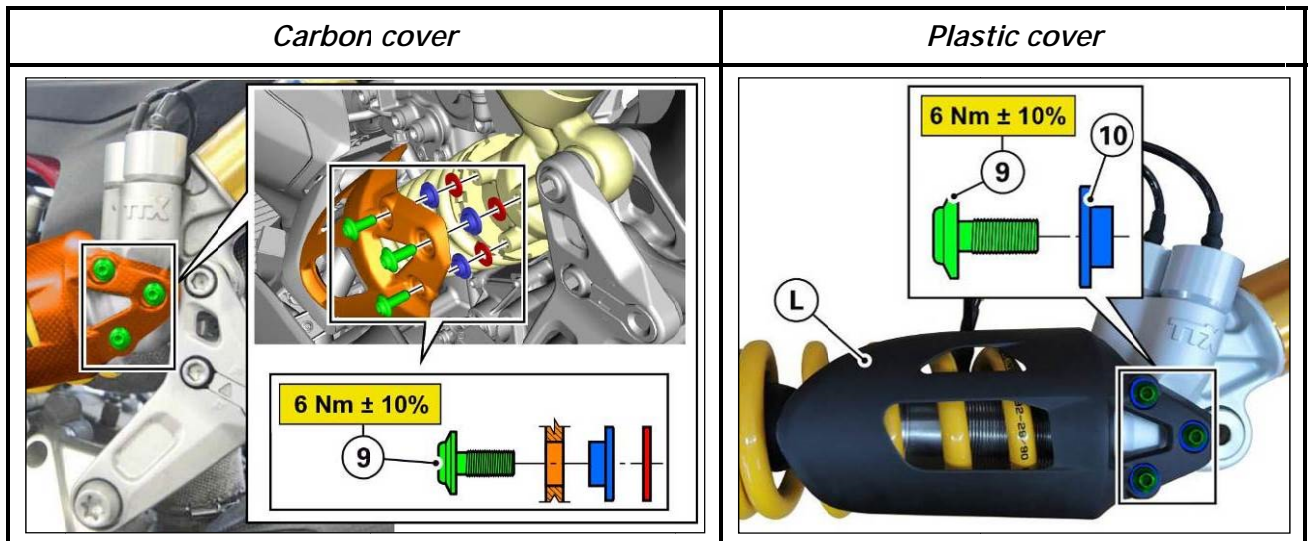

- 9) Install the new **rear shock absorber (M)**, starting the **rear screw (7)** and the **front screw (7)** with the associated **spacer (8)** as shown in the figure.

Tighten the **2 screws (7)** to a torque of  **$45 \text{ Nm} \pm 10\%$** .



**NOTE**

Lubricate the threads and underhead of screws (7) with Grease (GADUS S2 V220 AD 2 recommended).

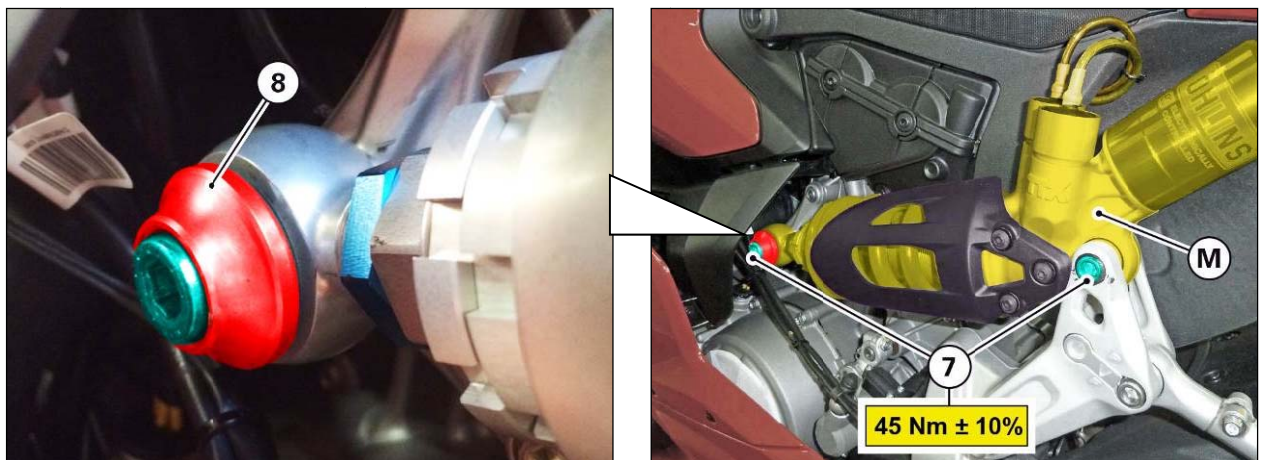



RCL-15-002 Panigale Ohlins TTX Shock  
Models: 1199 Panigale S Model Year 2014 (CAL and CDN versions)  
1199 Panigale R Model Year 2014 (CAL and CDN versions)  
1199 Superleggera Model Year 2014 (CAL and CDN versions)  
Recall Bulletin RCL-15-002

- 10) Install **cover (H)**: first fit **retainer (11)** into **vibration damper (12)** and shift downwards the cover itself fully home.

Fit the **2 pins (13)** into the **2 vibration dampers (14)**.



**NOTE**

Lubricate the retainer (11) and the 2 pins (13) with Grease (KLÜBERPLUS S 06/100 recommended) to facilitate the insertion.

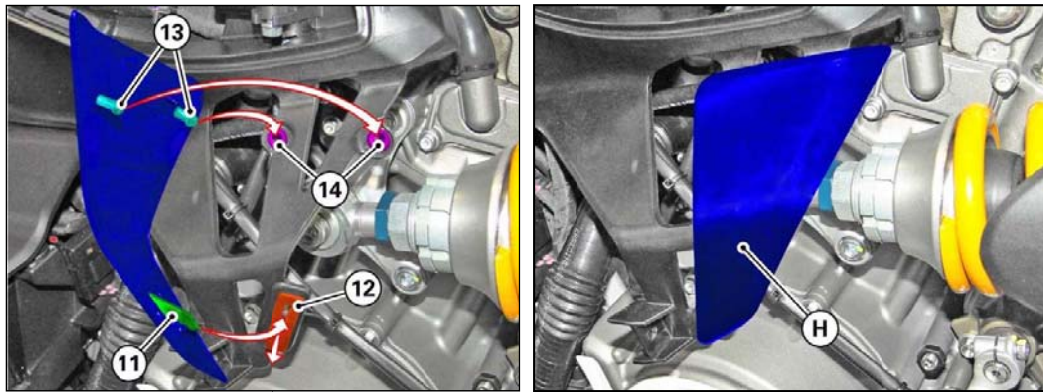

- 11) Join the rear shock absorber cables with a **self-locking tie (15)**.

Route the rear shock absorber cables through the opening on the external side of **rear subframe (N)**.

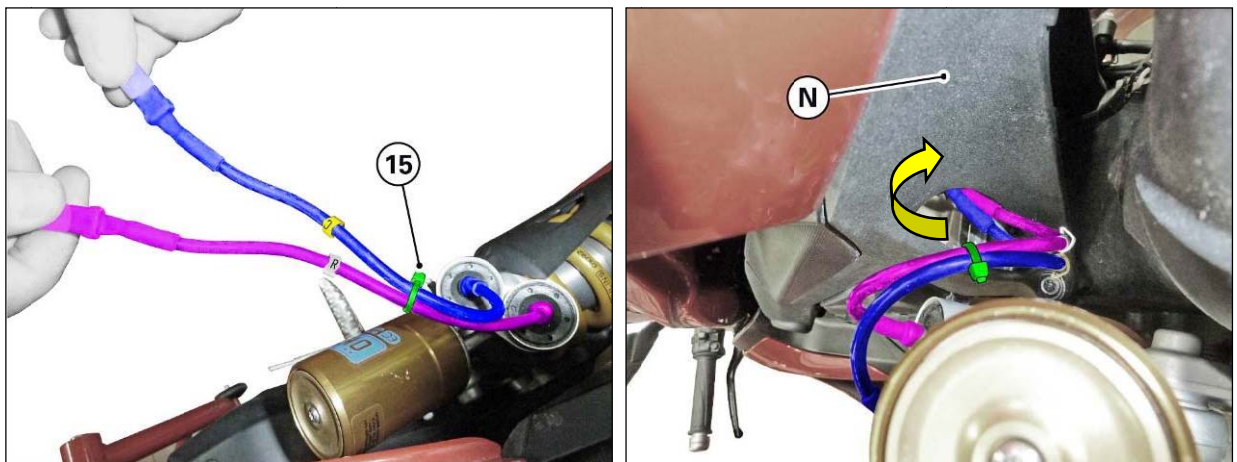



RCL-15-002 Panigale Ohlins TTX Shock  
Models: 1199 Panigale S Model Year 2014 (CAL and CDN versions)  
1199 Panigale R Model Year 2014 (CAL and CDN versions)  
1199 Superleggera Model Year 2014 (CAL and CDN versions)  
Recall Bulletin RCL-15-002

12) Connect *connectors (F)* and *(G)*.



**WARNING**

The *connector (F)* of *cable "C"* (yellow tag) must be connected to the wiring branch identified by the tag with the wording "*COMPRESS*".

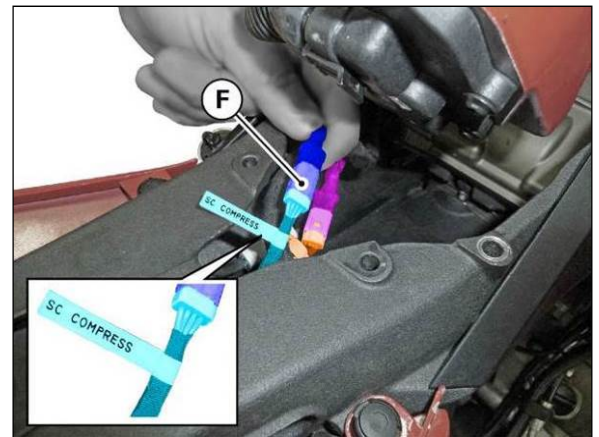
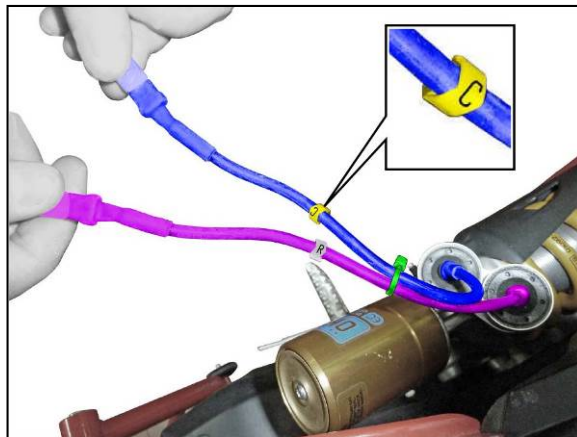

The *connector (G)* of *cable (R)* (white tag) must be connected to the wiring branch identified by the tag with the wording "*REBOUND*".

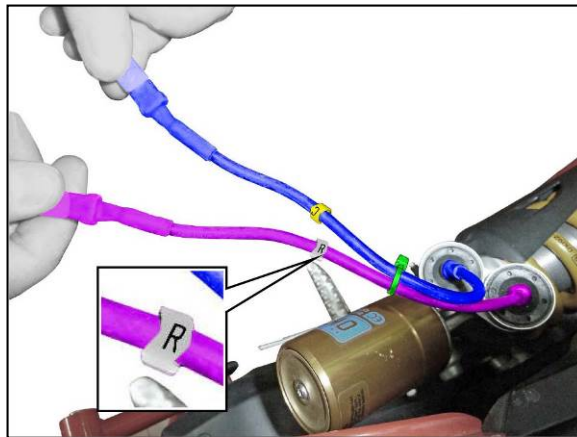



RCL-15-002 Panigale Ohlins TTX Shock  
Models: 1199 Panigale S Model Year 2014 (CAL and CDN versions)  
1199 Panigale R Model Year 2014 (CAL and CDN versions)  
1199 Superleggera Model Year 2014 (CAL and CDN versions)  
Recall Bulletin RCL-15-002

- 13) Install **tank lower bracket (E)** to **rear subframe (I)** positioning it as in the figure and tighten the **2 threaded stud bolts (5)** to a torque of **10 Nm ± 10%**.



**NOTE**

Lubricate the threads and underhead of the 2 stud bolts with Grease (GADUS S2 V220 AD 2 recommended).

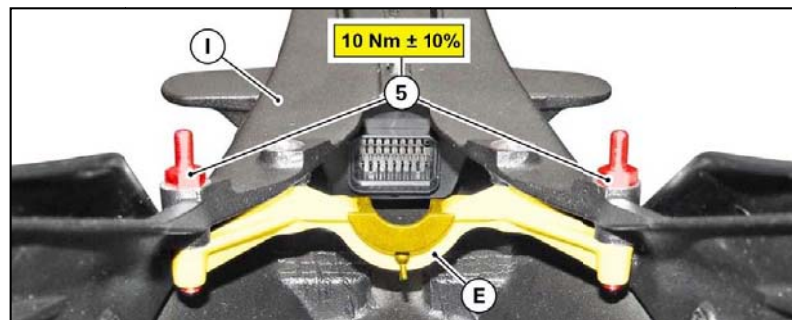

- 14) Secure the rear light cable, the BBS cable and the rear shock absorber adjustment cables to **tank lower bracket (E)** using a **self-locking tie (16)** as shown in the figure.

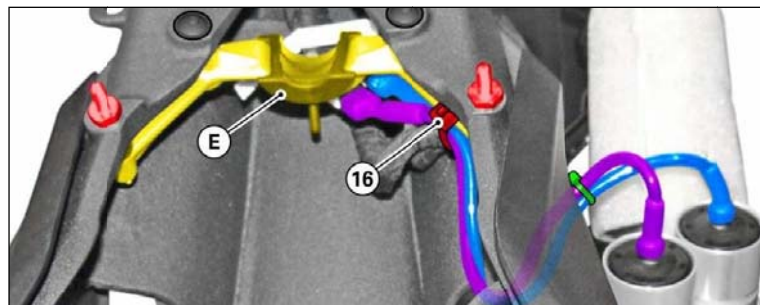

- 15) Remove shim (D) and lower fuel tank (C).



**WARNING**

Ensure that the breather pipes of fuel tank (C) are correctly positioned.



RCL-15-002 Panigale Ohlins TTX Shock  
Models: 1199 Panigale S Model Year 2014 (CAL and CDN versions)  
1199 Panigale R Model Year 2014 (CAL and CDN versions)  
1199 Superleggera Model Year 2014 (CAL and CDN versions)  
Recall Bulletin RCL-15-002

- 16) Install **tank upper bracket (B)** tightening the **2 screws (4)** to a torque of **10 Nm ± 10%** and the **2 nuts (3)** on the **threaded stud bolts (5)** to a torque of **6 Nm ± 10%**.



**NOTE**

Lubricate the thread of screws (4) with Grease (GADUS S2 V220 AD 2 recommended).

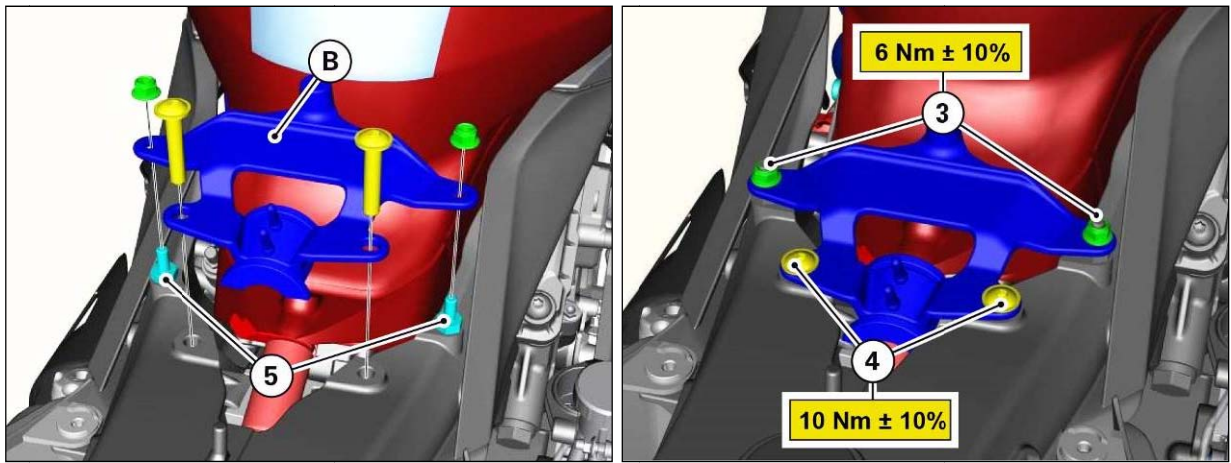

- 17) Install the ignition switch cover tightening the **2 screws (2)** to a torque of **2.5 Nm ± 10%** and the **2 special nuts (1)** to a torque of **8 Nm ± 10%**

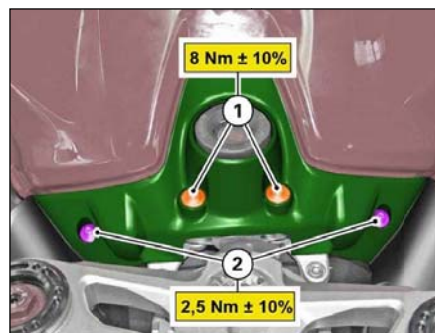

- 18) Release the motorcycle by sliding the belt out of rear sub-frame and install the rider seat (See Sect.05 "Fairing" of the Workshop Manual). Tighten the seat securing screw to a torque of **5 Nm ± 10%**.



RCL-15-002 Panigale Ohlins TTX Shock  
Models: 1199 Panigale S Model Year 2014 (CAL and CDN versions)  
1199 Panigale R Model Year 2014 (CAL and CDN versions)  
1199 Superleggera Model Year 2014 (CAL and CDN versions)  
**Recall Bulletin RCL-15-002**

**Spare Parts**

The only spare part required is the rear shock absorber for 1199 Panigale S or 1199 Panigale R: Part no.36521031A, since the rear shock absorber of 1199 Superleggera must be repaired at Öhlins repair center; see the procedure on page 2 of this document.

**Warranty time allowance and reimbursement procedure:**

Update procedure reimbursement will be issued through the standard warranty claim procedure via the section **Recall Campaigns** or **Vehicle History** of the DCS: the Warranty Claim is not pre-filled.

The above-described procedure has been coded as follows: **CR114**.

Labor time will be reimbursed for:

- inspecting the rear shock absorber lot number
- filling out the warranty claim

**12 minutes (2 labor units)**, according to the following flat rate table operation:

It is mandatory to include the verified lot number on the shock absorber in the warranty claim notes.

<i>Description</i>	<i>Time</i>	<i>Operation</i>
CR114 Rear shock absorber lot number check	12 minutes (2 UL)	2 – 999 – 113

In cases where the shock absorber is shipped to an Öhlins Repair Center, either for repair or after replacement, you will be reimbursed for a labor time of 60 minutes including the shock absorber removal and refitting operations and the time needed for packing and shipment.

<i>Description</i>	<i>Time</i>	<i>Operation</i>
Rear shock absorber removal, shipment to Öhlins repair center and refitting	60 minutes (10 UL)	2 – 999 – 114



RCL-15-002 Panigale Ohlins TTX Shock  
Models: 1199 Panigale S Model Year 2014 (CAL and CDN versions)  
1199 Panigale R Model Year 2014 (CAL and CDN versions)  
1199 Superleggera Model Year 2014 (CAL and CDN versions)  
**Recall Bulletin RCL-15-002**

***Customers:***

Ducati North America, Inc. will notify all known owners of affected vehicles directly by First Class mail. A sample copy of the owner notification letter is enclosed for your information.

Please be reminded that all motorcycles in your inventory, and to be delivered to Customers, must be updated during pre-delivery operations, and ALWAYS before delivery to the final Customer. For retailed units, the update must be performed upon the motorcycles' arrival for service or repairs.

***Campaign authorization:***

Ducati North America, Inc. will mail a notification letter to all known owners. If a customer does not present this notification letter, it is important that you confirm the eligibility for recall status on the DCS before you commence work. Reimbursement requests for duplicate recall campaign repairs will not be accepted.

***Dealer obligation:***

This program is designed to complete the necessary repairs and to achieve owner satisfaction. Therefore, we ask you to take prompt and courteous action in accordance with these directives.

Please provide a copy of this communication to every person in your dealership who has recall-related responsibilities.

Thank you for your cooperation.  
Ducati North America, Inc.  
Service Department





RCL-15-002 Panigale Ohlins TTX Shock  
Models: 1199 Panigale S Model Year 2014 (CAL and CDN versions)  
1199 Panigale R Model Year 2014 (CAL and CDN versions)  
1199 Superleggera Model Year 2014 (CAL and CDN versions)  
Recall Bulletin RCL-15-002

*Sample of Customer Letter*

## IMPORTANT SAFETY RECALL

This notice applies to your vehicle: VIN

Date

Name

Address

City, St, Zip

**Subject:** *Ducati Motorcycle:  
Model Year 2014 1199 Panigale S, 1199 Panigale R, and 1199 Superleggera*

NHTSA Campaign I.D. Number: 15V268  
Transport Canada Safety Recall I.D. Number: 2015-186

**Dealer Bulletin: RCL 15-002**

Dear Ducati Owner,

This notice is sent to you in accordance with the National Traffic and Motor Vehicle Safety Act & Canada Motor Vehicle Safety Act.

Ducati Motor Holding S.P.A. has decided that a defect which relates to motor vehicle safety exists in M.Y. 2014 1199 Panigale S, 1199 Panigale R, and 1199 Superleggera motorcycles. Our records indicate that you are the owner of a Ducati motorcycle affected by this safety recall campaign. Please take the time to read this letter and help us take the appropriate steps to ensure that your vehicle is operating properly.

### ***What is wrong?***

Ducati has identified a potential safety issue affecting all Model Year 2014 Ducati Panigale and Superleggera motorcycles. During assembly of the rear shock, the piston nut may not have been correctly torqued. An improperly torqued piston nut could affect the performance of the rear shock, which may cause the rider to lose control of the motorcycle, increasing the risk of a crash.

### ***What will Ducati do?***

To correct this condition, your authorized Ducati dealer will inspect and, if needed, perform the below operation:



RCL-15-002 Panigale Ohlins TTX Shock  
Models: 1199 Panigale S Model Year 2014 (CAL and CDN versions)  
1199 Panigale R Model Year 2014 (CAL and CDN versions)  
1199 Superleggera Model Year 2014 (CAL and CDN versions)

## Recall Bulletin RCL-15-002

For 1199 Panigale S or 1199 Panigale R models, the rear shock absorber will be replaced with a new shock absorber from Ducati.

For the 1199 Superleggera model, the rear shock absorber will be removed by the dealer and shipped to the supplier's repair center for refurbishment.

The Dealer will perform this repair at no cost to you for parts and labor. We request that you contact your authorized Ducati dealer and schedule an appointment, so that the required service can be performed without delay. Be advised that your motorcycle may be at the dealer for the duration of the repair; however, please ask your dealer for the specific time your vehicle will need to be at the dealership. To locate your nearest authorized Ducati dealer, please go to [www.ducati.com](http://www.ducati.com) and select the "dealer locator" or you may call toll free from the U.S. 1-800-231-6696.

Federal regulations require that any lessor receiving this recall notice must forward a copy of this notice to the lessee within ten days.

### Service Problem Help:

If you believe that your dealer has failed or is unable to perform the service within a reasonable period of time, please write to:

Ducati North America, Inc.  
Attn: Customer Service  
10443 Bandlely Drive  
Cupertino, CA 95014

If you still cannot obtain satisfaction, you may file a complaint with:

### ***For USA Customers:***

National Highway Traffic Safety Administration  
1200 New Jersey Avenue, SE  
Washington, D.C. 20590

Or call toll-free hotline at 1-888-327-4236 (TTY 1- 800-424-9153), or go to [HTTP://WWW.SAFERCAR.GOV](http://www.safercar.gov).

### ***For Canadian customers:***

Please contact Ducati customer service at 1-800-253-0499 or for additional information about the recall you can contact Transport Canada at 1-800-333-0510.



RCL-15-002 Panigale Ohlins TTX Shock  
Models: 1199 Panigale S Model Year 2014 (CAL and CDN versions)  
1199 Panigale R Model Year 2014 (CAL and CDN versions)  
1199 Superleggera Model Year 2014 (CAL and CDN versions)

## Recall Bulletin RCL-15-002

### ***TREADACT CUSTOMER REIMBURSEMENT PLAN***

If you have paid for the repair described in the attached letter, and you would like to be considered for reimbursement, please contact your authorized Ducati dealer. Expenses from repair facilities outside of the authorized Ducati dealer network will be considered; however, the procedure must meet Ducati North America's standards.

Your authorized Ducati retailer will request a copy of your owner notification letter, as well as, a copy of your previously paid invoice. They inspect the vehicle, if still in your possession, prior to submitting a claim on your behalf to Ducati North America, Inc. for reimbursement.

Please note the following:

Only a repair subject of this safety recall campaign is reimbursable. Ducati North America, Inc will not reimburse consequential expenses such as towing, rental, accommodations, and damage repairs.

We recommend that your authorized Ducati dealer be your primary contact on this issue. We anticipate that your authorized Ducati dealer will be able to answer any questions that you may have regarding your qualifications for reimbursement of a previous repair; however, our Customer Relations Dept. may be contacted at 408-253-0499 for any special assistance required.

We regret any inconvenience to you from this action; however, your safety and satisfaction are important to us. We request that you bring your Ducati motorcycle to your nearest authorized Ducati dealer at your earliest convenience.

Thank you for riding Ducati.

Sincerely,

Ducati North America  
Service Department