



TECHNICAL SERVICE BULLETIN

Victory Motorcycle

Bulletin Number: V-15-01 A-B
Model Years: 2013-2015

Date: January 06, 2015

Safety Bulletin Service Bulletin Service Alert Fax Production Update Kit

Distribution: Owner / Principal Service Manager Sales Manager Parts Manager Technicians

This Service Bulletin is located at www.polarisdealers.com

-Confidential and Proprietary-

IMPORTANT SAFETY NOTICE! STOP SALE

SUBJECT: 2013-2015 Victory Motorcycles – Fuel Pump Replacement

PURPOSE:

Some 2013-2015 Victory motorcycles may have been manufactured with a fuel pump assembly that does not meet Victory quality standards. Victory has identified an insufficient clearance between the fuel pump body and impeller which can interfere with normal fuel pump operation. Motorcycles assembled with an affected fuel pump may experience a sudden loss of fuel pressure causing the engine to stall. This could cause the vehicle operator to lose control, increasing the risk of a vehicle crash.

POTENTIALLY AFFECTED MODELS:

Model Year	Model Number	Model Name	Vehicle Identification Number Range
2013	ALL MODEL NUMBERS (Except Vision / Boardwalk / Judge)	ALL MODELS (Except Vision / Boardwalk / Judge)	Enter the Vehicle Identification Number (VIN) into 'Unit Inquiry' to verify whether a vehicle is affected by this Safety Bulletin.
2014			
2015	V15LB36NT, NTA	VICTORY GUNNER	

Not all VINs included in the POTENTIALLY AFFECTED MODELS table will be affected by this campaign. Use the Unit Inquiry feature on your dealer website to determine whether a specific VIN is affected.

WHAT YOUR DEALERSHIP SHOULD DO:

Wholegood Units:

1. **STOP ALL SALES** of affected units until this Safety Bulletin has been completed. After the bulletin is completed and a warranty claim has been filed, it is acceptable to resume sales.
2. Review your dealership's inventory to locate affected bikes.
 - Go to the STOP Site and click on the '**Click Here for a List of Your Dealership's Units with Open Bulletins / Recalls**' link located in the Search Options menu.
3. Perform the FUEL PUMP REPLACEMENT procedure outlined in this Safety Bulletin, on all affected units.
4. File a warranty claim for the appropriate bulletin number following completion and attach a bulletin completion decal as shown on page 3 of this bulletin.

Parts Stock Inventory:

1. Review your dealership's parts stock inventory to identify any potentially affected fuel pumps.
 - See **FUEL PUMP SERIAL NUMBER IDENTIFICATION** on page 3 of this bulletin to identify affected fuel pumps in your dealership's inventory. File a parts stock claim for any pumps falling within the affected range.

NOTE: Replacement fuel pumps (PN: 2521169 / PN: 2521171), required to complete this bulletin, are currently available to order in limited quantities. Victory Motorcycles is working with vendors to expedite additional inventory. Victory will provide regular updates pertaining to fuel pump availability via the Special Alerts section of the STOP Site. Expect the first update no later than January 16, 2015.

CUSTOMER NOTIFICATION:

A customer notification letter will be sent to all registered owners of affected machines. In addition to the notification letter sent by Victory Motorcycles, dealers are required to review sales records and contact consumers who have purchased an affected vehicle. Make arrangements to perform the steps outlined in this Safety Bulletin immediately.

WARRANTY CLAIM INFORMATION:

A single group claim may be submitted listing the complete (17 digit) Vehicle Identification Number for machines with the same model number. File claim type: **SB (Service Bulletin)**. DO NOT PUT MORE THAN ONE MODEL NUMBER ON A CLAIM.

FUEL PUMP REPLACEMENT – CRUISERS	
SERVICE BULLETIN #	V-15-01A
CLAIM TYPE	SB (Service Bulletin)
LABOR ALLOWANCE	60 Minutes (1.0 Hour)
CLAIM PART NUMBERS	N/A – Auto Process Bulletin

FUEL PUMP REPLACEMENT – CROSS COUNTRY / CROSS ROADS / HARD-BALL	
SERVICE BULLETIN #	V-15-01B
CLAIM TYPE	SB (Service Bulletin)
LABOR ALLOWANCE	60 Minutes (1.0 Hour)
CLAIM PART NUMBERS	N/A – Auto Process Bulletin

PARTS INFORMATION:

V-15-01A – CRUISERS

PART NUMBER / DESCRIPTION	7170107 (QTY.1) – Service Bulletin Completion Decal 2521169 (QTY.1) – Asm, Fuel Pump* 5413346 (QTY.1) – Seal, Fuel Pump 7518923 (QTY.10) – Screw, Fuel Pump
PARTS AVAILABILITY	Available to order. NOTE: *2521169 is currently available to order in <u>limited quantities</u> . Check your STOP Site Special Alerts for regular updates pertaining to fuel pump availability.
DIRECT-SHIP FROM VICTORY?	No
TO BE ORDERED BY DEALER?	Yes

V-15-01B – CROSS COUNTRY / CROSS ROADS / HARD-BALL

PART NUMBER / DESCRIPTION	7170107 (QTY.1) – Service Bulletin Completion Decal 2521171 (QTY.1) – Asm, Fuel Pump* 5413346 (QTY.1) – Seal, Fuel Pump 7518923 (QTY.10) – Screw, Fuel Pump
PARTS AVAILABILITY	Available to order. NOTE: *2521171 is currently available to order in <u>limited quantities</u> . Check your STOP Site Special Alerts for regular updates pertaining to fuel pump availability.
DIRECT-SHIP FROM VICTORY?	No
TO BE ORDERED BY DEALER?	Yes

PARTS RETURN OR DISPOSAL INFORMATION:

Dealers & Distributors: Under no circumstances shall the part removed in this repair be re-used, sold, or re-purposed for another application. It is your dealership / distributorship's responsibility to make sure every part replaced is taken out of circulation and disposed of properly.

For North American Dealers: Once the warranty claim for each unit has processed, please review the "Check Returned Parts List" on your dealer website to determine whether or not Polaris has asked for the part(s) to be returned. If the part(s) were not identified as needing to be returned to Polaris, please dispose of the part(s) properly.

SERVICE BULLETIN COMPLETION DECAL:

A Service Bulletin Completion Decal (PN 7170107) must be completed for this bulletin repair. Place the decal beneath the LH side cover as shown. If you require more decals, order them through normal Polaris parts ordering channels.

Sincerely,



Doug Koch
Technical Service and Warranty Manager

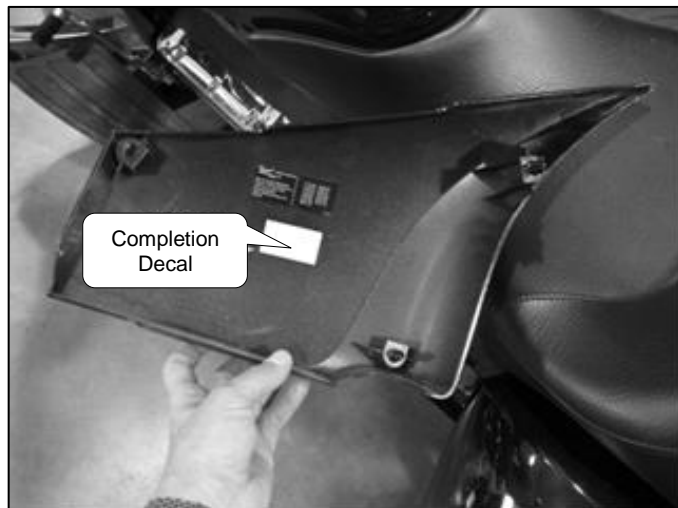

FUEL PUMP SERIAL NUMBER IDENTIFICATION:

NOTE: Fuel pump serial number identification is only applicable for parts stock inventory. Fuel pumps mounted on a motorcycle with an affected VIN should be replaced and do not require serial number verification.

The six (6) digit fuel pump serial number can be found on the sticker located on the fuel pump mounting flange.

Cruiser Fuel Pump

PN: 2521169

Affected Serial Number Range: 302020-304289

Cross Country / Cross Roads / Hard-Ball Fuel Pump

PN: 2521171

Affected Serial Number Range: 302150-304289

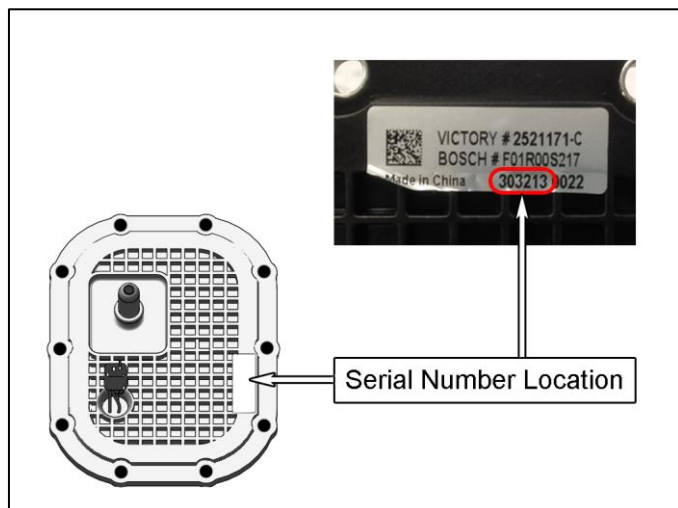

FUEL PUMP REPLACEMENT (ALL AFFECTED MODELS)

CAUTION:

- Allow engine and exhaust to cool completely before disconnecting fuel line or removing tank.
- Replace all mounting screws and pump seal when installing the replacement fuel pump.
- Do not kink or bend fuel pickup hose upon removal.
- Be careful when removing the fuel pump to avoid damaging the fuel pump, electrical wiring, or hoses.

IMPORTANT: The following procedure summarizes the fuel pump replacement procedure for all Victory Motorcycle models affected by this Safety Bulletin. For more detailed information pertaining to Fuel System Service, or special tools, refer to Chapter 5 in the applicable Victory Motorcycle Service Manual. If you have any questions that cannot be answered by the service manual, please call Victory Technical Service.

1. Drain fuel from tank using a vacuum or siphon pump designed for fuel systems.

Cross Country / Cross Roads / Hard-Ball ONLY: The fuel level sensor float arm ① is located in the left side of the fuel tank. Careless use of a pump or suction hose could damage the float arm or sensor.

2. Remove the fuel tank as outlined in Chapter 5 of the appropriate Victory Service Manual.
3. Lay the fuel tank on a protective cloth with the pump facing UP. Be prepared to contain any fuel spillage as a small amount of fuel will remain in the tank.

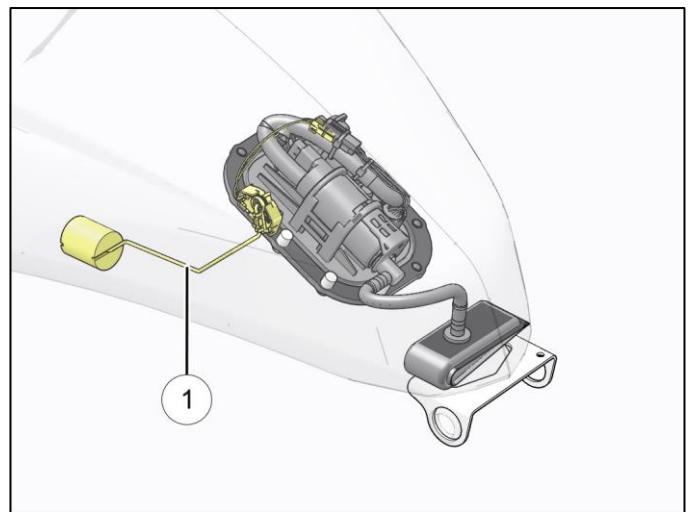

4. Loosen all mounting screws ② evenly in a cross pattern. Remove screws and discard.
5. Remove vent line and drain line if necessary to gain clearance.

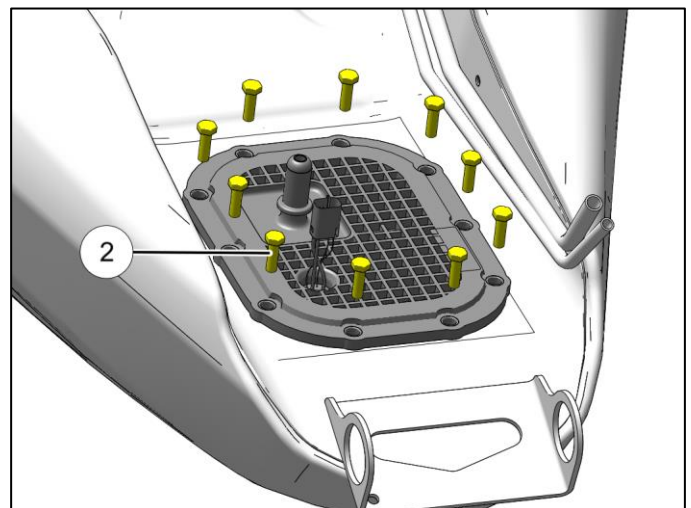

- Lift the front edge of the pump ③ upward until resistance is felt.
- Gently push wires and fuel line at front edge of pump away from the edge of the tank opening to gain more clearance for pump removal.

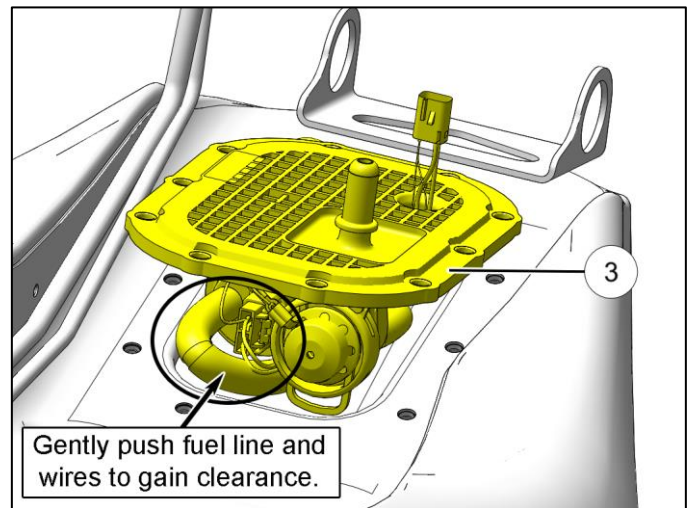

- Carefully remove the fuel pump assembly.
Cross Country / Cross Roads / Hard-Ball ONLY: Disconnect the fuel level sensor ④ prior to lifting the pump assembly out of tank.

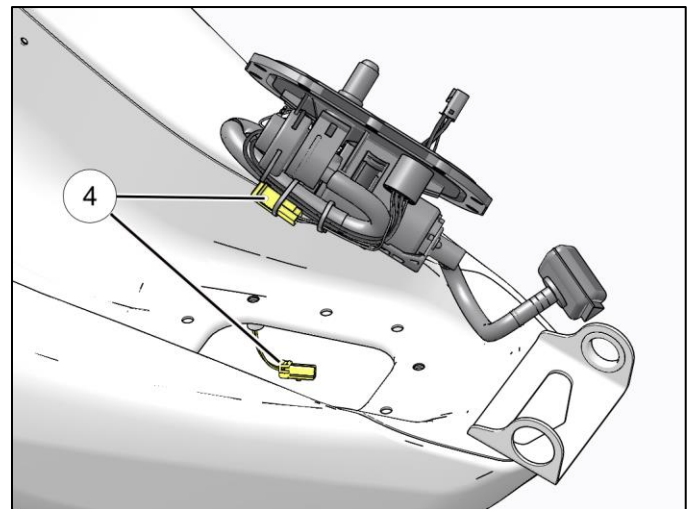

- Install a new fuel pump seal ⑤ into the mounting flange of the new pump by pressing it firmly into the pump flange groove.
- Clean seal mating surface on the fuel tank and inspect closely for scratches or surface damage that would prevent the pump from sealing properly.

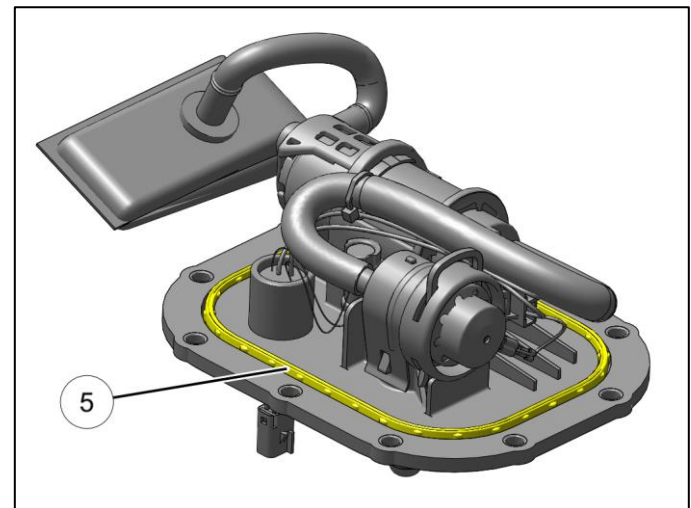

11. Install the new fuel pump assembly making sure the pickup filter lands at the lowest possible point in the tank.

Cross Country / Cross Roads / Hard-Ball ONLY: Verify that the pickup filter ⑥ is positioned between the baffle plates ⑦ in the rear of the tank or fuel starvation may occur when fuel level is low.

12. Start the NEW fuel pump mounting screws in each hole until they are all finger tight.

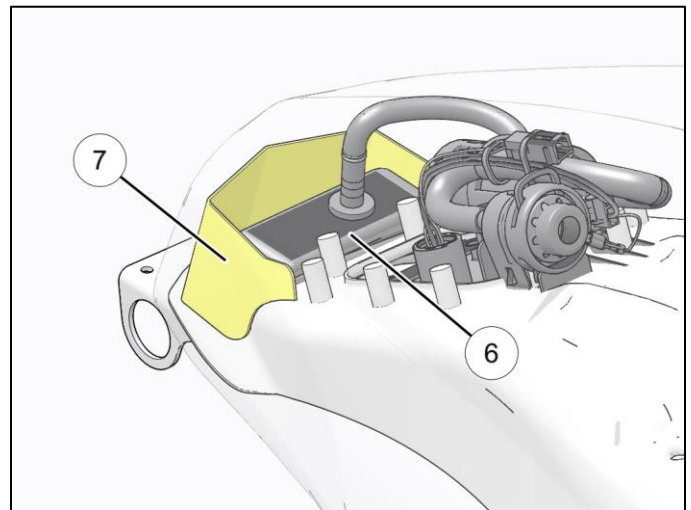

13. Torque the fuel pump screws in a star pattern following the specified torque sequence.

TORQUE:

Fuel Pump Screws: **43 in-lbs (4.8 Nm)**

14. Repeat final torque one additional time.
15. Add fuel and check for leaks before reinstalling the fuel tank.
16. Install fuel tank as outlined in Chapter 5 of the appropriate Victory Service Manual.
17. Prime fuel system as outlined in your Victory service manual, inspect for leaks, test ride and verify correct vehicle operation.

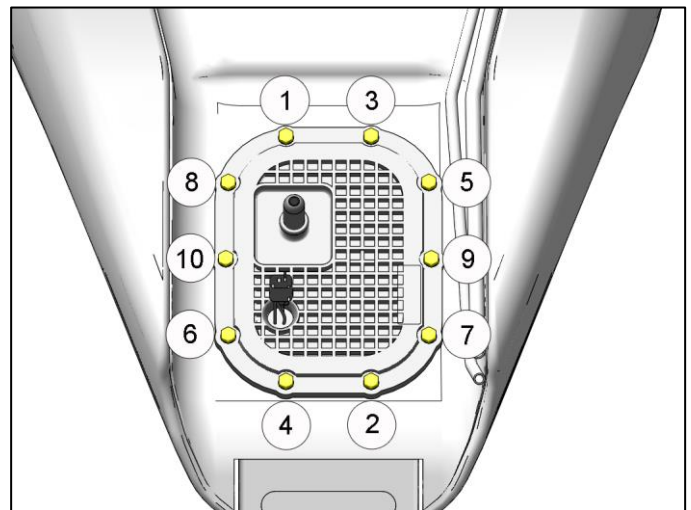

ADDITIONAL REFERENCE MATERIALS

Victory Service Manuals:

- **2012-2015 Cross Country, Cross Roads, Hard-Ball, Magnum Service Manual PN: 9925670**
- **2013-2015 Victory Cruiser Service Manual PN: 9925669**