



BLUE BIRD

SECOND FINAL NOTICE

DATE: SEPTEMBER 14, 2015
TO: BLUE BIRD OWNERS
SUBJECT: RECALL R14XE
STEERING SHAFT CLAMP MAY CONTACT RUBBER
CLOSEOUT BOOT

According to our records, we have not received confirmation that the above referenced recall dated July 8, 2014, has been completed. A copy of Recall R14XE is attached.

Your buses affected by Recall R14XE are identified by Blue Bird body number and VIN under Section 2 on the enclosed cover sheet.

If this is the first time you received notification of Recall R14XE, please read the enclosed notification carefully and follow the instructions provided. Recall R14XE must be completed as soon as possible.

If you have already had R14XE performed on your affected buses, please complete and mail the enclosed pink R14XE recall reply sheet to us in the enclosed postage paid pink reply envelope so we may update our recall records. Be sure the reply sheet is filled out properly.

Questions regarding this recall campaign should be directed to me at (478) 822-2242 or lisa.hancock@blue-bird.com.

Thank you for your prompt attention to this matter.

Sincerely,

Lisa Hancock
Corporate Recall Administrator
Blue Bird Body Company

BLUE BIRD BODY COMPANY
P.O. Box 937 – 402 Blue Bird Blvd – Fort Valley, Georgia – (478) 825-2021



R14XE

IMPORTANT SAFETY RECALL NOTICE

**NHTSA RECALL NO. 15V-124 SCHOOL BUS
NHTSA RECALL NO. 15V-118 NON-SCHOOL BUS**

March 25, 2015

Dear Blue Bird Owner:

This important safety recall notice applies to your bus(es) identified by both Blue Bird Body Number and Vehicle Identification Number (VIN) on the attached pink reply sheet.

This notice is sent to you in accordance with the requirements of the National Traffic and Motor Vehicle Safety Act.

Blue Bird Body Company has decided that a defect which relates to motor vehicle safety exists in certain 2016 model year Blue Bird All American model school and non-school bus(es) manufactured from September 11, 2014 through January 12, 2015.

On the subject buses, the intermediate steering shaft bellows clamp may contact the rubber closeout boot at the floor which could result in increased steering effort. At no time would steering become fully inoperable. However, Blue Bird determined the degradation in steering effort is deemed an undesirable occurrence and could potentially result in a vehicle crash. Blue Bird is conducting a recall to correct this defect.

To correct this condition, the intermediate steering shaft bellows clamp must be removed and shaft bellows raised to eliminate any interference with rubber close out boot. Steering shaft bellows will be re-secured with a new clamp. If close out boot is damaged or worn, boot must be replaced. Instructions for completing Recall R14XE are enclosed.

Your Blue Bird bus(es) affected by this recall are identified by both Blue Bird Body Serial Number(s) and Vehicle Identification Number (VIN) on the enclosed pink reply sheet.

If you no longer own the subject bus(es), please complete the appropriate section of the yellow cover sheet and return to Blue Bird in the enclosed pink postage prepaid envelope.

You may contact your Blue Bird dealer to arrange to have this recall performed. Or, if you prefer, you may perform this recall yourself or have a qualified repair facility convenient to you perform this recall. A qualified technician should perform this recall.

BLUE BIRD BODY COMPANY
P.O. Box 937 – 402 Blue Bird Blvd – Fort Valley, Georgia – (478) 825-2021



BLUE BIRD

Blue Bird Body Company
Page 2

R14XE

To receive replacement parts for Recall R14XE, complete and return the enclosed Recall R14XE Inspection Parts Request Form to Blue Bird in the pink, self-addressed, postage prepaid envelope. Be sure to provide a valid shipping address as UPS does not deliver to P.O. Boxes. You should retain a copy of the parts request form for your records.

Labor time to relocate rubber closeout boot and install new retaining clamp according to Recall R14XE instructions is 0.1 hours (six minutes) per bus.

Labor time to remove and replace a torn rubber close out boot and install new retaining clamp, if needed, according to Recall R14XE instructions is 1 hour per bus.

Reimbursement for labor may be obtained by completing the pink "Labor Reimbursement" sheet provided and returning it to Blue Bird in the enclosed pink postage prepaid envelope. **Be sure to enter the date inspected and or repaired, the odometer reading and check Column "A" to indicate the steering boot was only relocated. Check column "B" if boot was torn and was replaced.** Completed Labor Reimbursement sheets may also be faxed to 478-822-2467. Be sure to retain a copy of the reply sheet for your records.

If the modifications directed by this notification were performed on your bus prior to the receipt of this recall notification, complete and sign the recall reply sheet and attach a copy of the work order/invoice. Mail the documents in the **pink** self-addressed postage paid envelope included with the recall notification to Blue Bird for warranty consideration. Reimbursements will be made in accordance with the requirements of the National Highway Transportation Safety Act, Title 49 Code of Federal Regulations, Parts 573 and 577.

Federal law requires that any vehicle lessor receiving this recall notice must forward a copy of this notice to the lessee within ten days.

If Blue Bird Body Company should fail to or is unable to remedy this condition without charge to you, you may contact:

**ADMINISTRATOR
NATIONAL HIGHWAY TRAFFIC SAFETY ADMINISTRATION
1200 NEW JERSEY AVENUE, SE
WASHINGTON, D.C. 20590**

Or, you may call The National Highway Traffic Safety Administration toll free at:

1-888-327-4236 TTY 1-800-424-9153 Or, go to: [HTTP://WWW.SAFERCAR.GOV](http://WWW.SAFERCAR.GOV)



BLUE BIRD

Blue Bird Body Company
Page 3

R14XE

Questions regarding this recall campaign should be directed to me at (478) 822-2242 or lisa.hancock@blue-bird.com.

Sincerely,

Lisa Hancock

Lisa Hancock
Corporate Recall Administrator
Blue Bird Body Company



Steering Shaft Floor Boot Seal

RECALL

Models Affected: 2012-2016 Model Year Front Engine/Rear Engine All American/TX3/TX4 Buses

ISSUE

Clamp on intermediate steering column shaft bellows may contact steering shaft floor boot seal and tear floor boot seal and bind steering shaft causing difficulty in steering.

CORRECTIVE ACTION

Remove clamp and raise bellows on intermediate steering shaft beyond interference and secure with narrow worm gear clamp.

PROCEDURE

WARNING: Always follow all Federal, State, Local and Shop safety standards and use proper safety equipment, and thoroughly read and understand all instructions before performing these procedures.

1. Park bus on a level surface, apply parking brake, turn off ignition, remove ignition key and chock rear wheels.
2. Inspect steering shaft floor boot seal for wear or damage and slit is toward front of bus.
3. If damaged or worn, complete section **Steering Shaft Floor Boot Seal Replacement** before continuing.
4. After completing section **Steering Shaft Floor Boot Seal Replacement** or if there is no damage or wear to the floor boot seal, complete section **Intermediate Steering Column Shaft Bellows Adjustment**.

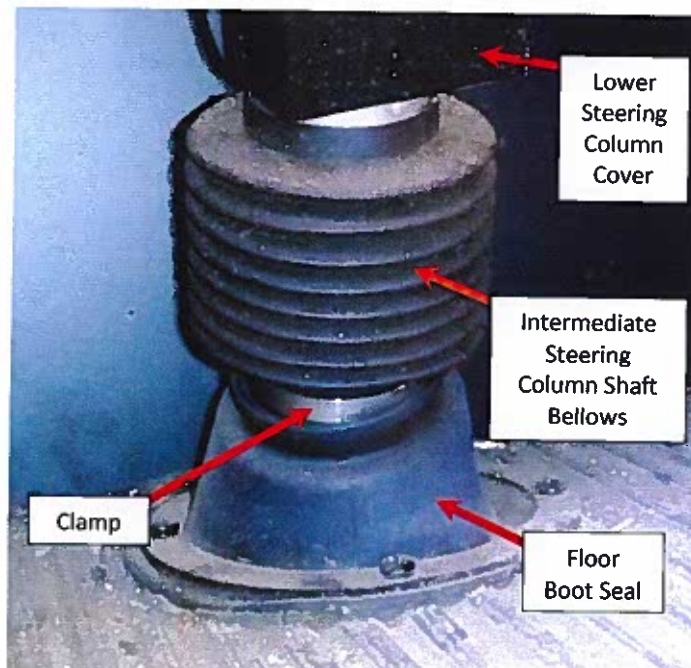

Fig. 1



**Steering Shaft
Floor Boot Seal**

RECALL

Intermediate Steering Shaft Assembly Exploded View

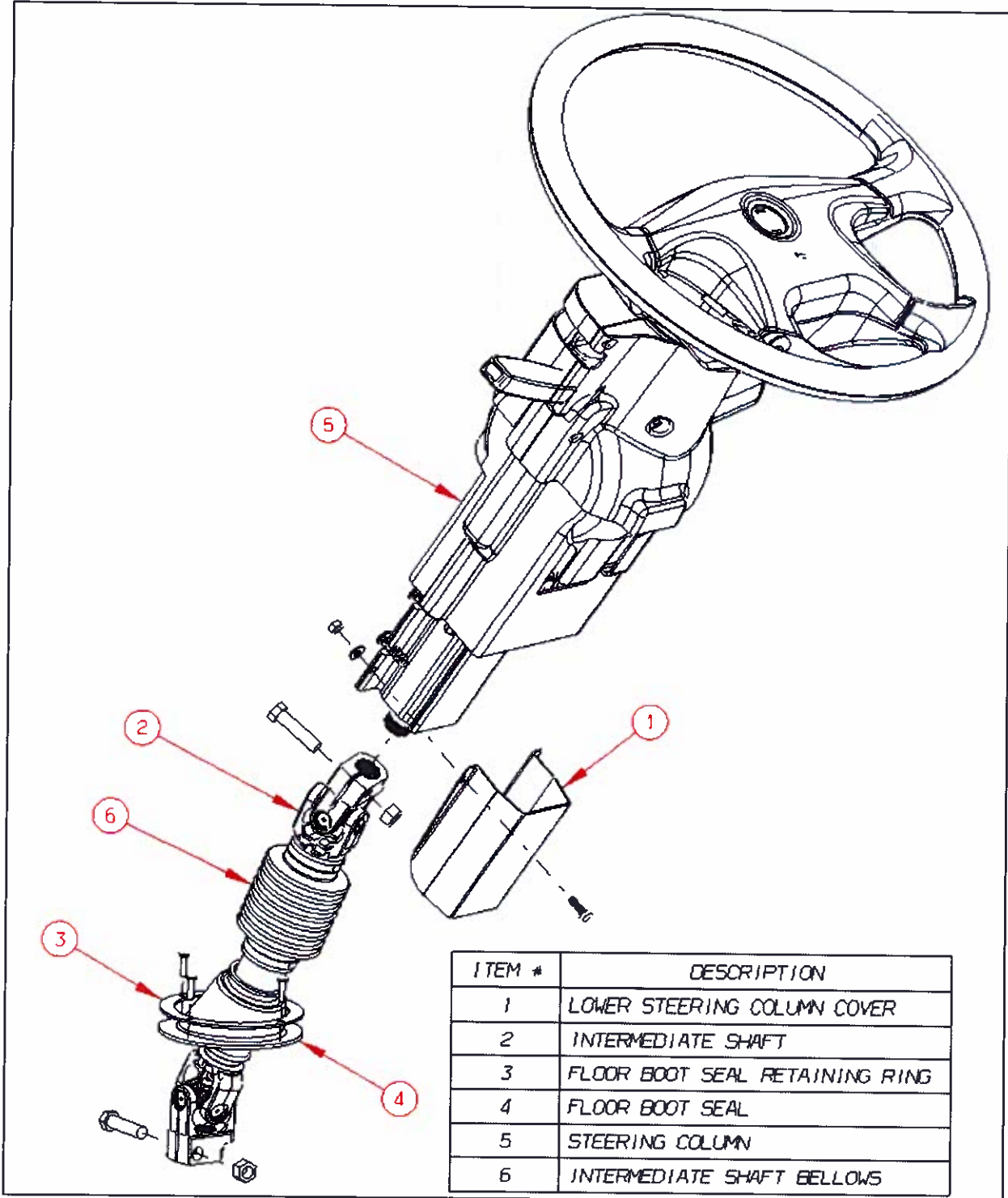

RECALL CAMPAIGN R14XE



Steering Shaft Floor Boot Seal

RECALL

Steering Shaft Floor Boot Seal Replacement (Use exploded view on page 2 for reference)

1. Remove lower steering column cover and discard fasteners. (Fig. 2)
2. Remove four screws from steering shaft floor boot seal retaining ring. Boot seal and retaining ring should be loose from floor. Keep screws for re-use. (Fig. 2)
3. Remove pinch bolt and nut from upper portion of intermediate shaft. Discard bolt and nut. (Fig. 3)
4. Remove pinch bolt and nut from lower portion of intermediate shaft. Discard bolt and nut. (Fig. 3)
5. Compress intermediate shaft together while removing it from splines on steering column and transfer box.
6. Pull intermediate shaft up through hole in floor.
7. Cut off bellows clamp on lower section of intermediate shaft. (See Fig. 3)

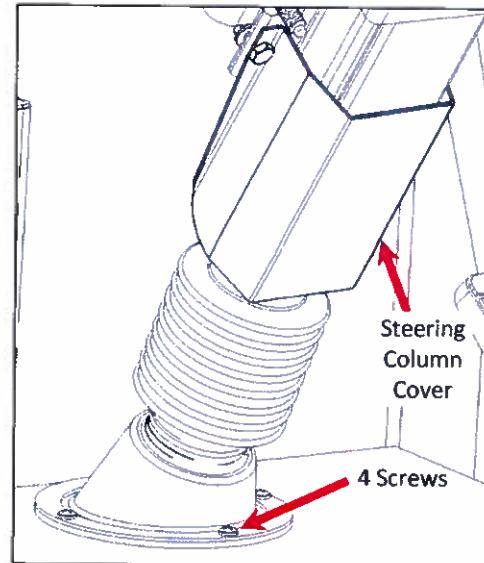

Fig. 2

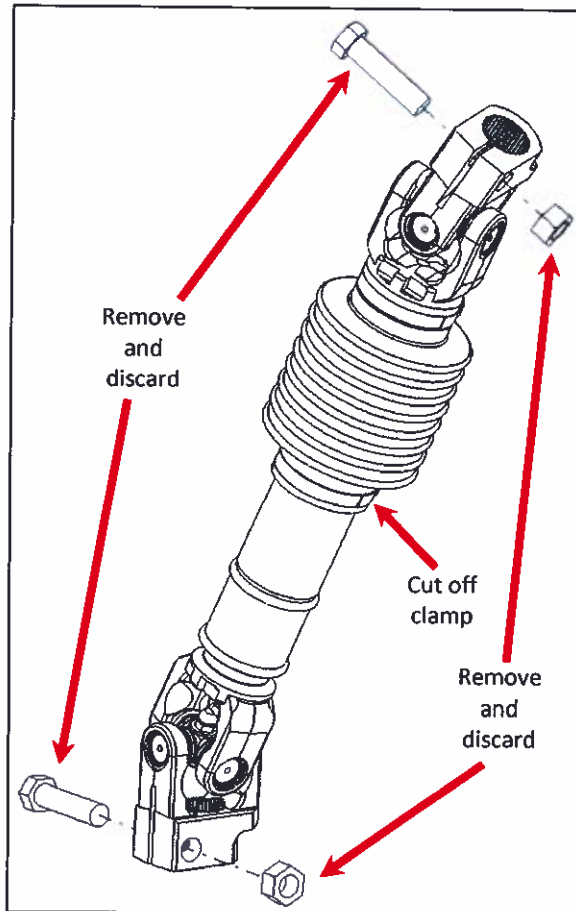

Fig. 3

RECALL CAMPAIGN R14XE



Steering Shaft Floor Boot Seal

RECALL

Steering Shaft Floor Boot Seal Replacement (continued)

(Use exploded view on page 2 for reference)

8. Replace floor boot seal on intermediate steering shaft and re-install intermediate shaft using new fasteners. (See Fig. 4)
 - a. Torque pinch bolts 36-43 FT-LBS.
9. Re-install floor boot seal with retaining ring with four screws. Slit in floor boot seal should be oriented toward front of bus. (See Fig. 5)
10. Install lower steering column cover with new fasteners. (Fig. 6)
 - a. Torque nuts to 37-41 FT-LBS.

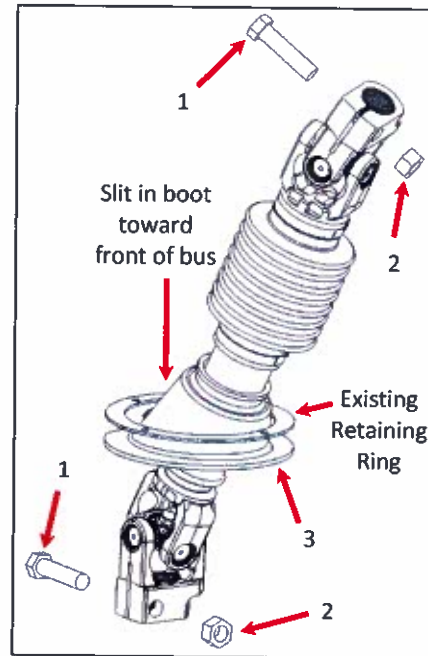

Fig. 4

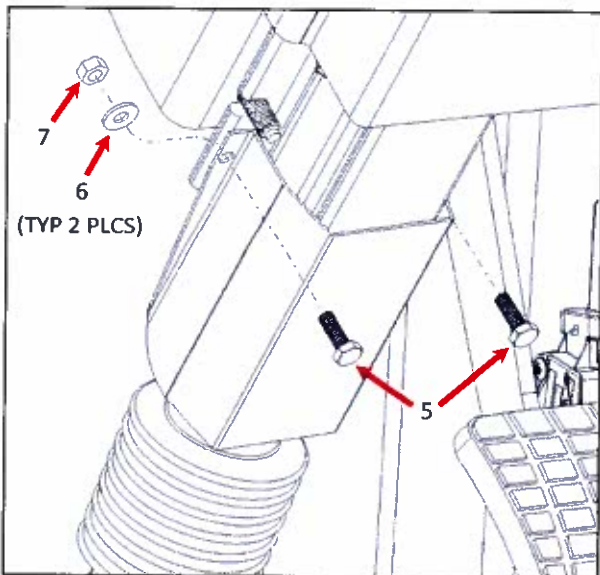

Fig. 6

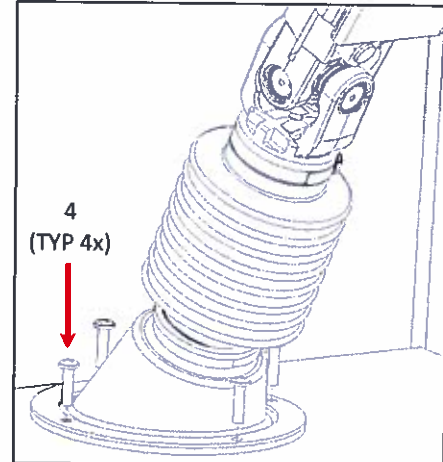

Fig. 5

Parts List for Steering Shaft Floor Boot Seal Replacement

Item #	Part Number	Description	Qty
1	01916980	CAPSCREW,HEX HD,7/16-14 X 1 3/4,GR8,YELZNDH	2
2	00997080	NUT,HEX HD,7/16-14,LOCKING,GR 8,CADMIUM WAX	2
3	10019820	BOOT,SEAL,STRG SHAFT D3	1
4	01943695	SCREW,10-16X3/4,AB,PH1,PAN HD,BLK ZN	4
5	00977132	CAPSCREW,HEX HD,1/4-20 X 3/4,GR 5,YEL DICH	2
6	01247709	WASHER,FLAT,17/64 ID X 5/8,YEL ZN DICH	2
7	02001345	NUT,HEX HD,1/4-20,LOCKING,YELLOW DICH	2

RECALL CAMPAIGN R14XE



Steering Shaft Floor Boot Seal

RECALL

Intermediate Steering Column Shaft Boot Adjustment

(Use exploded view on page 2 for reference)

1. Cut off bellows clamp on lower section of intermediate shaft if present. (Fig. 7)
2. Push bellows up until it is no longer in contact with steering shaft floor seal boot.
 - a. Minimum 0.50 inch gap between floor seal boot and bellows.
3. Open new worm gear clamp until it releases then secure it around bellows. (Fig. 8)
 - a. New clamp must ride all the way around in groove on bellows.
 - b. Torque clamp to 10-15 in-lb.
4. Inspect the floor boot seal and bellows for minimum 0.50 inch clearance all the way around the intermediate steering column shaft.
5. Recall is complete. Place bus back into service.

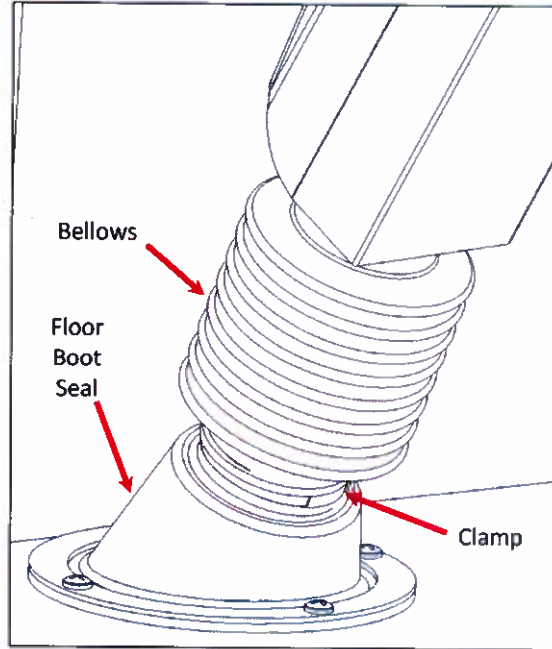

Fig. 7



Fig. 8

Parts List for Intermediate Steering Column Shaft Boot Adjustment			
Item #	Part Number	Description	Qty
8	10039119	CLAMP, WORM GEAR, 2IN, 3524	1

RECALL CAMPAIGN R I 4 X E

