



BLUE BIRD

SECOND FINAL NOTICE

DATE: MARCH 11, 2016
TO: BLUE BIRD OWNERS
SUBJECT: RECALL R15YB
POTENTIAL FOR REAR ENGINE EXHAUST HANGERS FAILING

According to our records, we have not received confirmation that the above referenced recall dated March 6, 2015, has been completed. A copy of Recall R15YB is attached.

Your buses affected by Recall R15YB are identified by Blue Bird body number and VIN under Section 2 on the enclosed cover sheet.

If this is the first time you received notification of Recall R15YB, please read the enclosed notification carefully and follow the instructions provided. Recall R15YB must be completed as soon as possible.

If you have already had R15YB performed on your affected buses, please complete and mail the enclosed pink R15YB recall reply sheet to us in the enclosed postage paid pink reply envelope so we may update our recall records. Be sure the reply sheet is filled out properly.

Questions regarding this recall campaign should be directed to me at (478) 822-2242 or lisa.hancock@blue-bird.com.

Thank you for your prompt attention to this matter.

Sincerely,

Lisa Hancock
Corporate Recall Administrator
Blue Bird Body Company



BLUE BIRD

R15YB

IMPORTANT SAFETY RECALL NOTICE

NHTSA RECALL NO. 15V059 SCHOOL BUS

NHTSA RECALL NO. 15V060 NON-SCHOOL BUS

DATE: March 6, 2015

Dear Blue Bird Owner:

This important safety recall notice applies to your bus(es) identified by both Blue Bird Body Number and Vehicle Identification Number (VIN) on the attached yellow cover sheet.

This notice is sent to you in accordance with the requirements of the National Traffic and Motor Vehicle Safety Act.

Blue Bird Body Company has decided that a defect which relates to motor vehicle safety exists in certain 2011 through 2016 model year Blue Bird All American Rear Engine model school and non-school buses manufactured from June 5, 2010 through January 13, 2015, and equipped with optional Cummins diesel engines.

On the subject buses, the exhaust system hanger straps may fail under extreme conditions causing damage to the Selective Catalytic Reduction (SCR) and Diesel Particulate Filter (DPF) housings. This hanger failure may allow the exhaust system to partially or completely dislodge from some or all of its mounting points. If the housings were to fall onto the roadway, this could create a road hazard, increasing the risk of a crash. Blue Bird is conducting a recall to correct this defect.

To correct this defect, new exhaust hanger assemblies and exhaust support cables will be supplied to replace each of the four existing exhaust hanger assemblies.

Your Blue Bird bus(es) affected by this recall are identified by both body serial number(s) and vehicle identification number (VIN) on the enclosed yellow and pink reply sheets. If you no longer own the subject bus(es), please complete the appropriate section of the yellow reply sheet and return to Blue Bird in the enclosed pink postage prepaid envelope.

Blue Bird recommends you contact your local or nearest Blue Bird Dealer to arrange for this recall to be performed. The Dealer can perform the repairs, or arrange for repairs to be performed by a service facility authorized by the Dealer. However, you may elect to perform this recall yourself or pay another independent repair facility to perform this recall. A qualified technician should perform this recall.

If you elect to perform this recall yourself or pay another independent repair facility to perform this recall, complete and submit the Pink Owner's Recall Reply Sheet provided. The Reply Sheet includes a section for the owner to request reimbursement of the owner's labor or to request

BLUE BIRD BODY COMPANY

P.O. Box 937 – 402 Blue Bird Blvd – Fort Valley, Georgia – (478) 825-2021

reimbursement for a labor invoice paid by the owner to an independent repair facility. The Owner's Recall Reply Sheet can be mailed in the postage prepaid envelope provided, faxed to 478-822-2467, or email copies of the documents and supporting documents to lisa.hancock@blue-bird.com.

Of course, if your Blue Bird Dealer performs the recall or arranged for repairs to be performed by a service facility authorized by the Dealer, the Blue Bird Dealer will notify Blue Bird about the completion of the recall.

To receive replacement parts for Recall R15YB, sign and return the enclosed yellow reply sheet to Blue Bird in the pink, self-addressed, postage prepaid envelope. Be sure to provide a valid shipping address as UPS does not deliver to P.O. Boxes. You should retain a copy of the reply sheet for your records.

Labor time to perform recall R15YB is 1.3 hours.

If the modifications directed by this notification were performed on your bus prior to the receipt of this recall notification, complete and sign the recall reply sheet and attach a copy of the work order/invoice. Mail the documents in the pink self-addressed postage paid envelope included with the recall notification to Blue Bird for warranty consideration. Reimbursements will be made in accordance with the requirements of the National Highway Transportation Safety Act, Title 49 Code of Federal Regulations, Parts 573 and 577.

Federal law requires that any vehicle lessor receiving this recall notice must forward a copy of this notice to the lessee within ten days.

If Blue Bird Body Company should fail to or is unable to remedy this condition without charge to you, you may contact:

**ADMINISTRATOR
NATIONAL HIGHWAY TRAFFIC SAFETY ADMINISTRATION
1200 NEW JERSEY AVENUE, SE
WASHINGTON, D.C. 20590**

Or, you may call The National Highway Traffic Safety Administration toll free at:

1-888-327-4236 TTY 1-800-424-9153 Or, go to: [HTTP://WWW.SAFERCAR.GOV](http://WWW.SAFERCAR.GOV)

Questions regarding this recall campaign should be directed to me at (478) 822-2242 or lisa.hancock@blue-bird.com.

Sincerely,

Lisa Hancock

Lisa Hancock
Corporate Recall Administrator
Blue Bird Body Company



Potential for Rear Engine Exhaust Hangers Failing

(Revised December 7, 2015)

RECALL

Models Affected: Certain Rear Engine All American Buses with a Selective Catalytic Reduction (SCR) and Diesel Particulate Filter (DPF).

ISSUE	CORRECTIVE ACTION
-------	-------------------

The rubber SCR and DPF hanger strap assembly may fail under extreme conditions causing extensive damage to the SCR and DPF modules.

Install new exhaust hanger strap assembly 10040843 (4 Places); and exhaust support cables, 10047279.

PROCEDURE

WARNING:

Always follow all Federal, State, Local, and Shop safety standards and use proper safety equipment, and thoroughly read and understand all instructions before performing these procedures.

CAUTION:

Allow exhaust system to cool prior to performing these procedures to prevent the risk of severe burns.

1. Park the bus on a level surface, apply parking brake, turn off engine, remove ignition key, and chock wheels.
2. Locate the four muffler hanger strap assemblies supporting the SCR and DPF at the rear of the bus.

Note: Inspect welded Main Support Brackets for damage (bent brackets or cracked welds) before installing new muffler hanger bracket assemblies. Replace, as needed.

3. Support the SCR and DPF, and replace muffler hanger strap assemblies (4 Places) with new assemblies 10040843 and add two exhaust support cables 10047279, two bolts 00803171, two nuts 00543934, and two nuts 02171809 per exhaust hanger strap assembly. Drill out slots at eight (8) mounting locations to 13/32 inch diameter. Do not reuse old nuts.

Torque upper 3/8" nut that comes with new bracket assembly 10040843 to 72 – 78 in-lb.

4. Torque lower 3/8" nuts (00543934 and 02171809) to 29 - 33 lb-ft. See Sheet 2 for illustration.

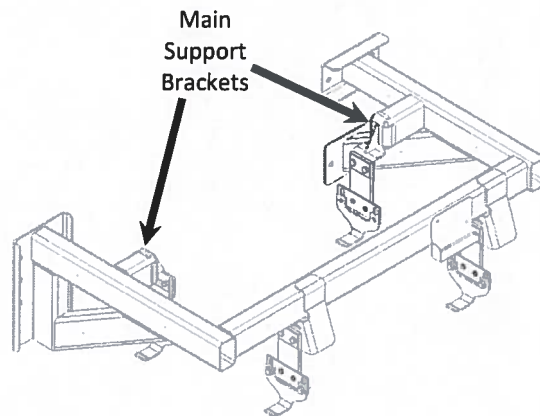
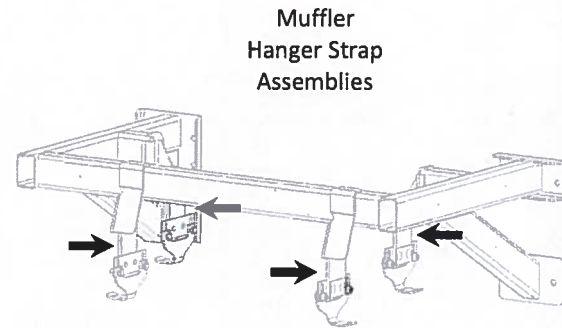

RECALL CAMPAIGN R I 5 Y B



Potential for Rear Engine Exhaust Hangers Failing
(Revised December 7, 2015)

RECALL

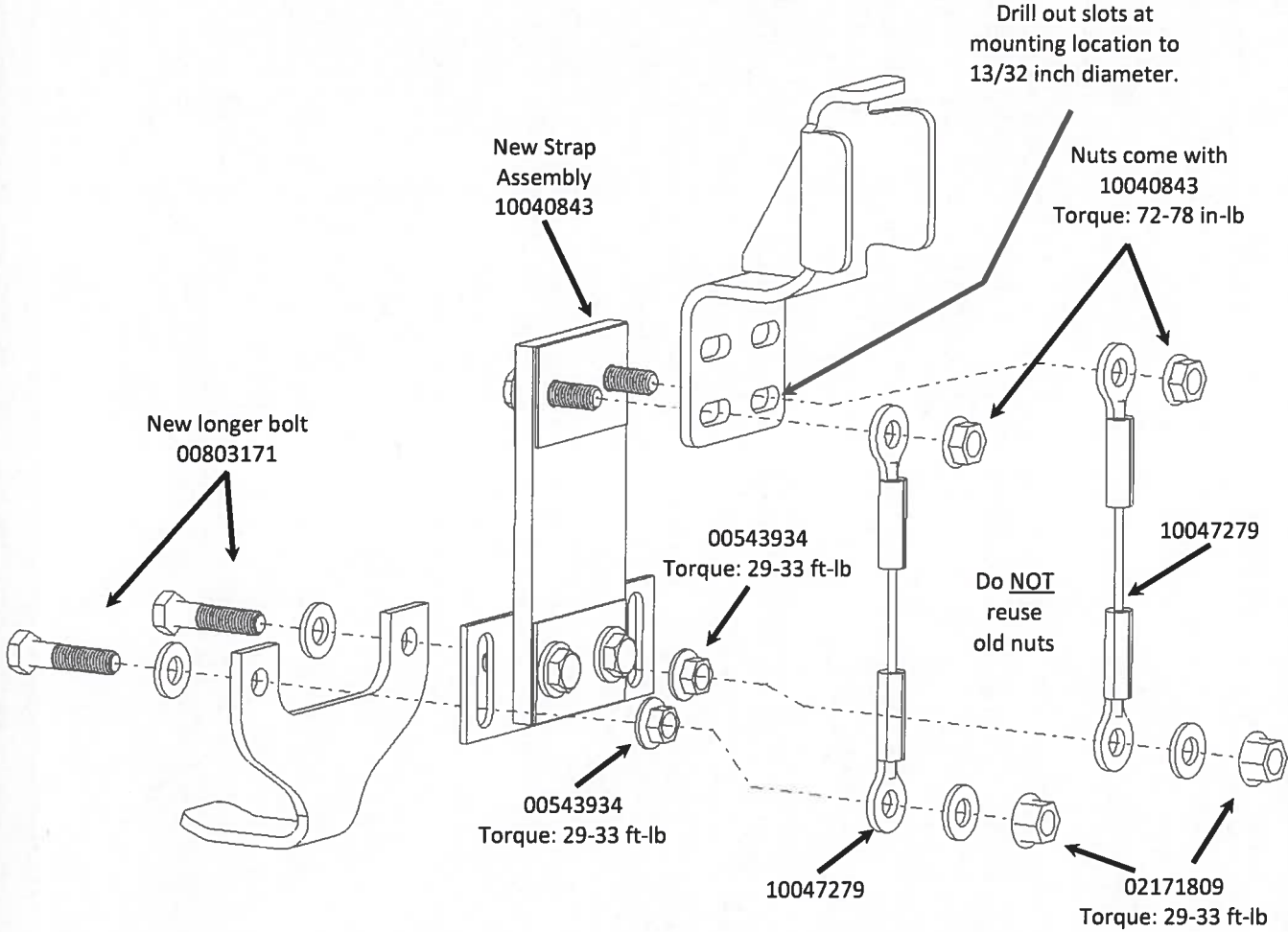

Parts List		
Part #	Description	Qty
10047279	CABLE ASSY, SUPPORT,6.00",EXHAUST, T3RE	8
10040843	BRACKET ASSY,EXH,HANGER,ADJUSTABLE,5.63	4
02171809	NUT,HEX HD,3/8-16,SM FLG LK	8
00543934	NUT,HEX HD,3/8-16,ZINC,LG FLG LK,YEL ZNDICH	8
00803171	CAPSCREW,HEXHD,3/8-16NCX1-1/2,GR8,YELZNDICH	8

Note: Re-use existing washers.

RECALL CAMPAIGN R15YB