



# Service Bulletin

American Honda Motor Co., Inc.

## SAFETY RECALL

### 2001-2015 GL1800/A, GL1800B/BD SECONDARY MASTER CYLINDER REPLACEMENT

*(This bulletin supersedes GL1800 #20 and GL1800 #22.)*

Honda is launching a Safety Recall of 2012-2015 GL1800/A and 2013-2015 GL1800B/BD motorcycles, and is implementing a recall remedy for 2001-2010 and 2012 GL1800/A motorcycles already subject to Safety Recall "JG6". Honda has determined that under conditions where the brake fluid is subject to prolonged aging due to a lack of maintenance (i.e., the brake fluid is not replaced for a long period of time despite the published maintenance schedule of replacement every 12,000 miles or two years, whichever comes first), deposits may form within the brake fluid. If sufficient deposits are formed, they can result in a malfunction of the secondary master cylinder, which may cause the rear brake to drag. A redesigned secondary master cylinder with new internal valving is now available to correct this condition; in addition, Honda has updated its brake fluid replacement service procedure to better ensure that all old brake fluid is removed from the system.

#### Safety Consequence

A dragging rear brake increases the risk of a crash and may generate enough heat to cause the rear brake to catch fire.

#### CUSTOMER NOTIFICATION

During the month of November 2015, Honda will mail a letter to all owners of affected motorcycles informing them that their motor-

cycle is being recalled for a safety related defect, or that a remedy is now available for the previously identified safety defect. The customer will be made aware of the safety risk and advised to have a Honda dealer replace the secondary master cylinder.

For your reference, copies of the applicable Customer Letters are reproduced on Pages 3 and 4 of this Service Bulletin.

#### AFFECTED UNITS

##### 2001-2015 GL1800/A

All units and types within the above model year range.

##### 2013-2015 GL1800B/BD "F6B"

All units within the above model year range.

#### DEALER INVENTORY

##### Do not sell any un-repaired units.

According to federal law, any affected units in your new inventory cannot be sold or leased until they are repaired with a replacement secondary master cylinder parts kit, and Honda policy prohibits the sale of new or used un-repaired units.

To search for applicable recalls on a specific unit, refer to *Unit Information on iN*.

To manage your affected inventory, use *eResponsibility Report on iN*.

**REPAIR VERIFICATION**

Before you begin the repair procedure, check if the repair has been performed on the unit.

- If there is a punch mark:
  - No further action is necessary
- If there is no punch mark:
  - You must proceed with the REPAIR PROCEDURE section of this Service Bulletin.

Remove the right engine side cover.

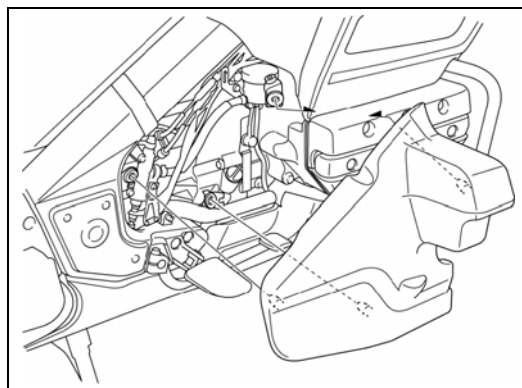

Look for a punch mark on the rear master cylinder lower mounting tab as shown.

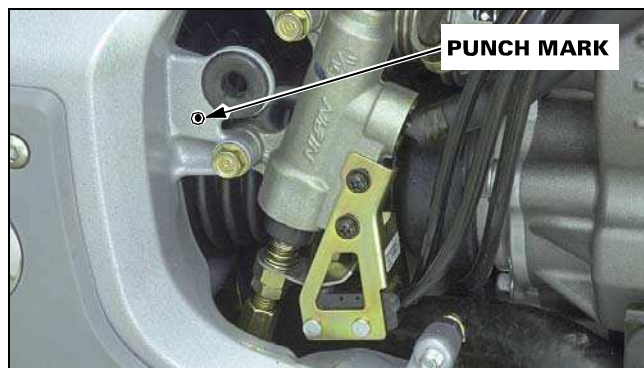

**REPAIR PROCEDURE**

The REPAIR and IDENTIFICATION procedures are located at the end of this bulletin.

**TRIKE CONVERSIONS or MODIFIED BRAKES:**

If the vehicle is a trike conversion, or has a modified, disabled, or removed secondary master cylinder (SMC) and the SMC is non-functional, note these facts on the R.O. and contact TechLine for further instructions:

***IN > Service > TechLine > Techline Connect***

Or call (800) 421-1900, option 9

**CLAIM INFORMATION**

This Safety Recall will be in effect indefinitely, regardless of the date of vehicle purchase. Normal warranty claim submission requirements apply. After completing the Service Bulletin repair procedure, submit one warranty claim per unit with the following information:

**WARRANTY CLAIM TEMPLATES**

**Trike Conversions**

TechLine will provide a warranty claim template during your initial contact.

**2001-2010 GL1800/A**

Template: JV6A  
Flat Rate Time: 2.2 hrs.

**2012-2015 GL1800**

Template: JV6B  
Flat Rate Time: 2.2 hrs.

**2013-2014 GL1800B/BD**

Template: JV6C  
Flat Rate Time: 2.2 hrs.

**2015 GL1800B/BD**

Template: JV6D  
Flat Rate Time: 2.2 hrs.

**PARTS INFORMATION**

**REQUIRED PARTS**

Initially, parts will be allocated to your dealership based upon your affected inventory. Later, parts will be available on open order.

Application	Part No. (Qty.)
GL1800/A - All model years '15 GL1800B/BD (Cruise control equipped)	06454-MCA-306 (1)
'13-'14 GL1800B/BD (Without cruise control)	06454-MJG-306 (1)
<b>Kit Contents (Qty.)</b>	
Secondary master cylinder (1)	
Rear master cylinder sub-assy. (1)	
Washer, oil bolt (7)	
Pin, split 2.0 mm (1)	
Nut, hex cap 10 mm (2)	
<b>Use only</b> Pro Honda DOT 4 Brake Fluid (6 bottles) (initially, automatically shipped separately from parts)	

**TEXT OF CUSTOMER LETTER**

**CUSTOMER LETTER IS FORTHCOMING**

**TEXT OF CUSTOMER LETTER**

**CUSTOMER LETTER IS FORTHCOMING**

# GL1800 #23 - REPAIR PROCEDURE



## Service Bulletin

American Honda Motor Co., Inc.

### SAFETY RECALL

OVERVIEW .....	1-2	PEDAL BRAKE LINE FLUID FLUSHING ....	1-9
PEDAL BRAKE LINE FLUID DRAINING .....	1-2	PEDAL BRAKE LINE FLUID FILLING .....	1-12
REPLACE THE REAR MASTER CYLINDER	1-4	PEDAL BRAKE LINE AIR BLEEDING .....	1-14
REMOVE THE FRONT WHEEL.....	1-7	CHECK THE REPAIR.....	1-14
REMOVE THE SECONDARY MASTER CYLINDER .....	1-8	IDENTIFICATION .....	1-14

'01-'10 GL1800/A

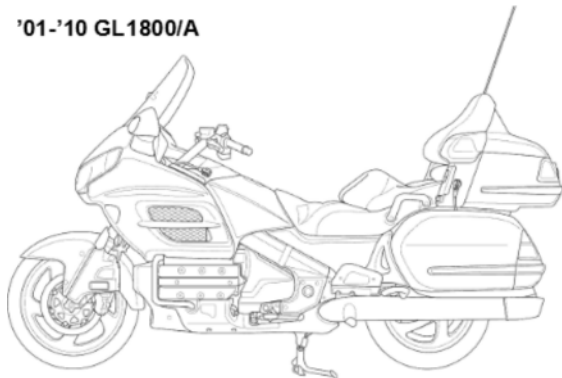

'12-'15 GL1800

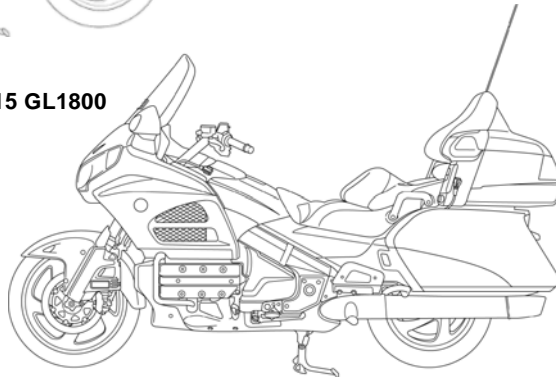

GL1800B/BD

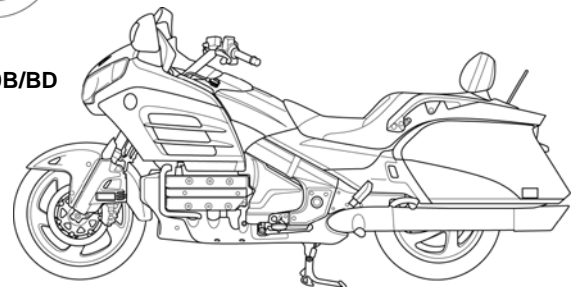

## OVERVIEW

### OBJECTIVE

This repair procedure, when properly executed, will eliminate most contaminants from the pedal brake system prior to the installation of the secondary master cylinder (SMC) parts kit.

The procedure differs significantly from the Service Manual brake filling/bleeding sequence, as it includes a fluid flushing procedure and the installation of a new rear master cylinder (to ensure all contaminants are removed from the pedal brake line) before the final fluid filling and bleeding. Carefully review the complete procedure before starting. AHM will issue Service Manual revision pages to update the Service Manual with the new brake fluid replacement procedure.

NOTE:

**Use only the provided Pro Honda DOT 4 brake fluid from sealed containers to ensure the quality of the repair procedure.**

### PARTS, SUPPLIES, AND TOOLS REQUIRED

In addition to common hand tools, the brake fluid replacement procedure requires the following parts, supplies and tool:

- Master cylinder kit, second/rear (For model application, see the PARTS INFORMATION section of this bulletin.)  
P/N 06454-MCA-306 (1) or  
P/N 06454-MJG-306 (1)
- **Use only** Pro Honda DOT 4 brake fluid (6 bottles per repair) Initially, automatically shipped separately from the parts kit.
- Applicable Service Manual
- Commercially available brake bleeder

### TRIKE CONVERSIONS or MODIFIED BRAKES

If the vehicle is a trike conversion, or has a modified, disabled, or removed secondary master cylinder (SMC) and the SMC is non-functional, note these facts on the R.O. and contact TechLine for further instructions.

## PEDAL BRAKE LINE FLUID DRAINING

### NOTICE

*Spilling fluid can damage painted, plastic or rubber parts. Place a shop towel over these parts whenever the system is serviced.*

NOTE:

- **Do not mix different types of fluid. They are not compatible.**
- Do not allow foreign material to enter the system when filling the reservoir.

### PEDAL BRAKE LINE FLUID DRAINING

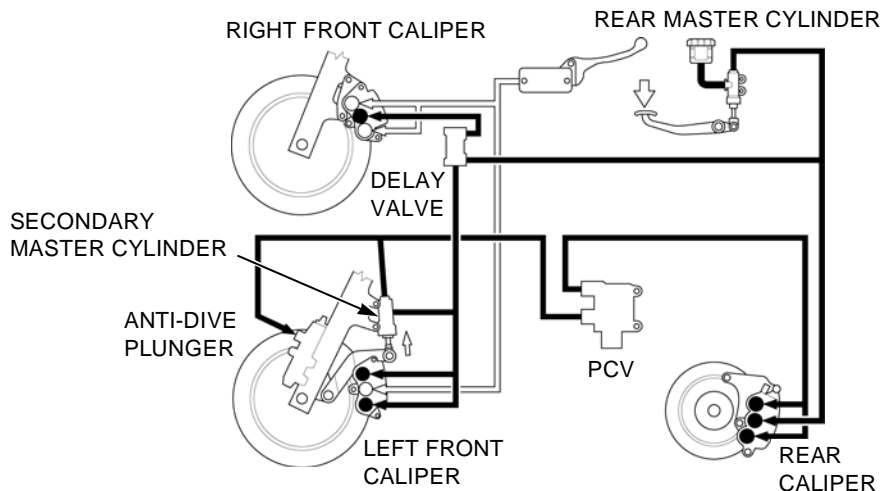

Refer to the Service Manual and remove the following:

- right engine side cover
- front fender A, both fender covers, and front fender B
- rear fender A

Support the motorcycle on its centerstand or a lift.

Remove the bolt [1] and rear master cylinder reservoir.

Remove the rear master cylinder reservoir cap [2], set plate [3], and diaphragm [4].

Temporarily install the reservoir and tighten the bolt.



Connect a commercially available brake bleeder [1] to the bleed valve of the pedal brake line as shown. Loosen the bleed valve and activate the brake bleeder until no more fluid flows out of the bleed valve. Close the bleed valve.



Perform the fluid draining procedure at each remaining valve of the pedal brake line in the following order:

1. right front caliper, lower: [1]
2. rear caliper, lower: [2]
3. anti-dive plunger: [3]
4. rear caliper, upper: [4]

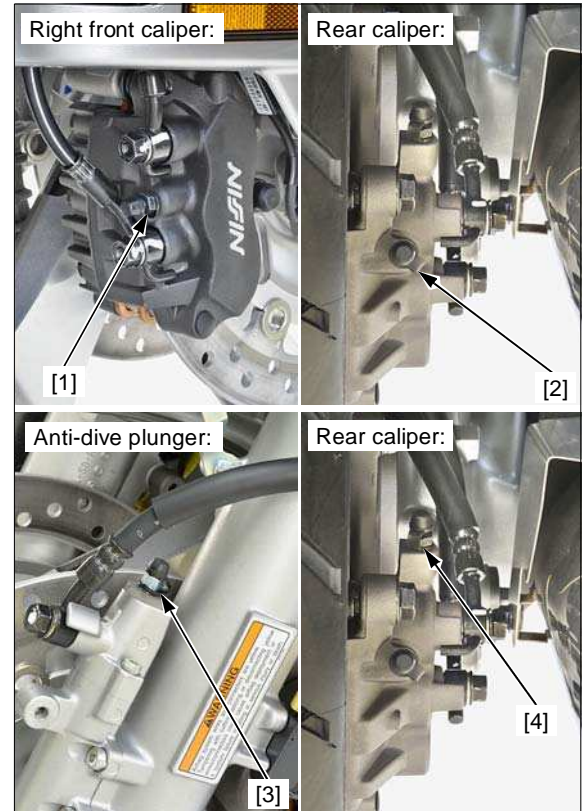

# REPLACE THE REAR MASTER CYLINDER

## REMOVAL

Remove the two screws and brake light/cruise cancel switch ('13 - '14 GL1800B: brake light switch) assembly [1] from the master cylinder.



Remove the two bolts [2] and right footpeg [3].  
Remove the pinch bolt [4] and brake pedal [5].

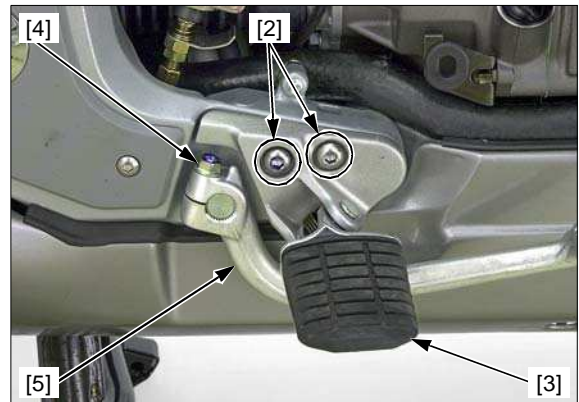

*When removing the hose and oil bolt, cover the ends of the hoses to prevent contamination.*

Remove the reservoir hose [1] from the master cylinder [2].

Disconnect the brake hose by removing the oil bolt [3] and sealing washers [4].

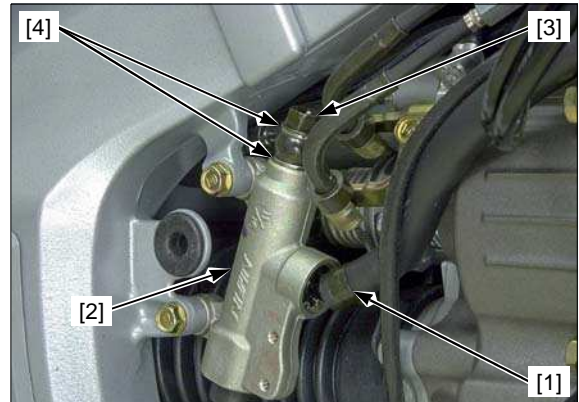

Unhook the spring end to remove the return spring [1] from the frame and pivot arm [2].

Release the drive shaft joint boot [3] from the engine.

Remove the master cylinder mounting bolts [4].  
Remove the pedal pivot arm from the frame while pushing the water hose aside, then remove the master cylinder/pivot arm assembly [5].





Remove the following from the master cylinder:

- split pin [1]
- joint pin [2]
- pivot arm [3]

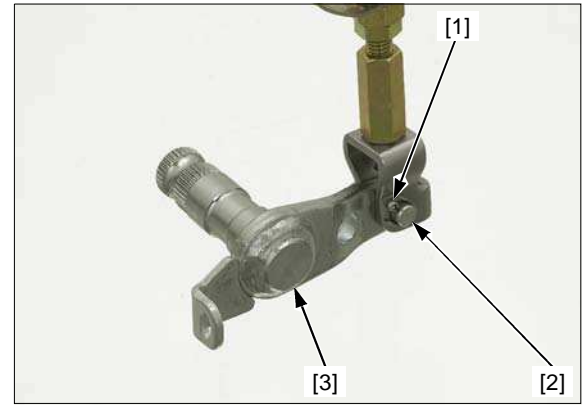

**CLEAN THE RESERVOIR AND OIL BOLT**

*Use a wire brush if necessary to clean the oil bolt threads.*

Thoroughly clean the reservoir [1], hose [2], and oil bolt [3] with **WATER** only. **DO NOT USE BRAKE CLEANER!**

Blow all components dry with compressed air.

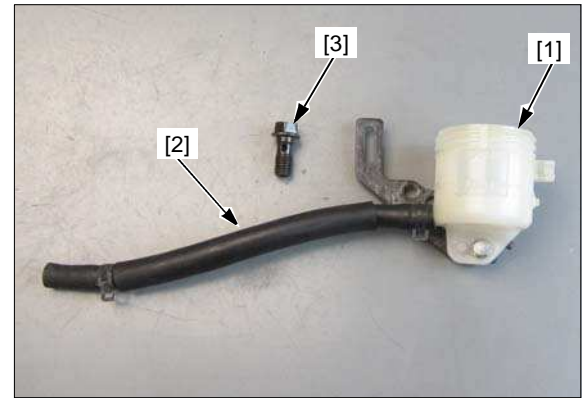

**INSTALLATION**

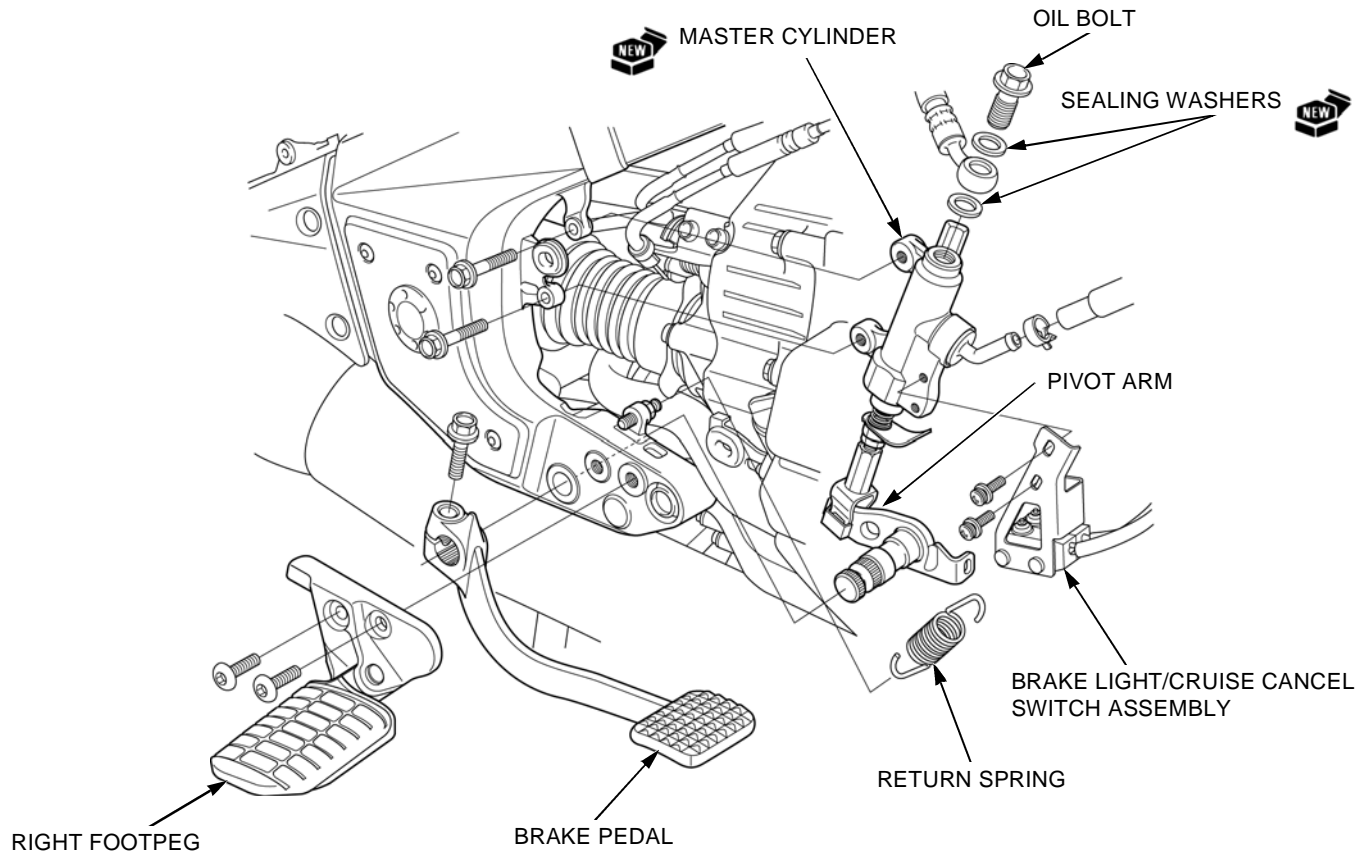

## GL1800 #23 - REPAIR PROCEDURE

Install the pivot arm [1] into the new master cylinder push rod joint with the joint pin [2] and a new split pin [3].

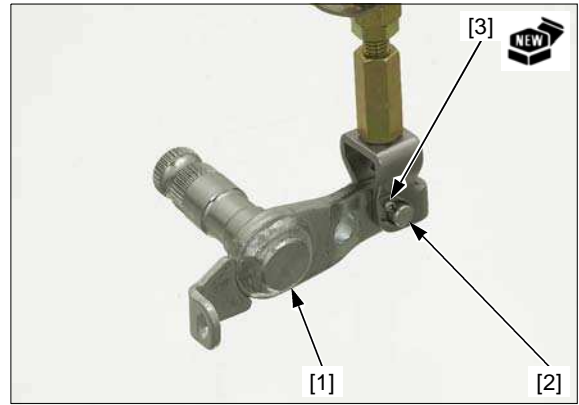

Apply grease to the pivot shaft groove of the pivot arm [1].

Place the master cylinder/pivot arm assembly [2] into the frame while pushing the water hose and driveshaft joint boot aside, then insert the pivot arm into the pivot hole, being careful not to damage its splines.

Install the master cylinder onto the frame and tighten the mounting bolts [3].

**TORQUE: 12 N·m (1.2 kgf·m, 9 lbf·ft)**

Install the joint boot [4] onto the engine.

Install the return spring [5] into the pivot arm and onto the frame stopper pin in the direction shown.

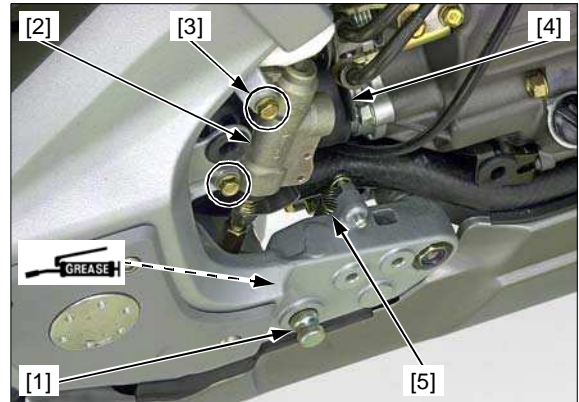

Install the reservoir hose [1] onto the joint.

Connect the brake hose to the master cylinder with the oil bolt [2] and new sealing washers [3], and tighten the oil bolt.

**TORQUE: 34 N·m (3.5 kgf·m, 25 lbf·ft)**

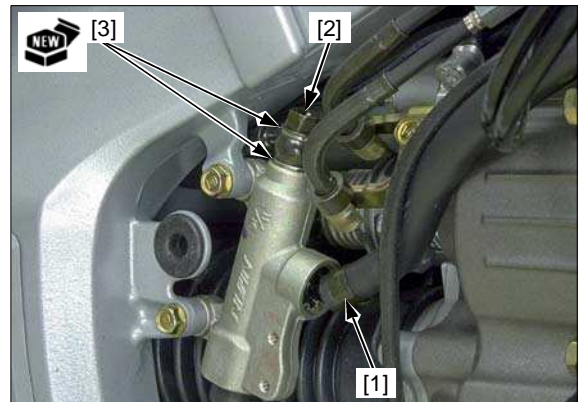

Install the brake pedal [1] by aligning the slit with the punch mark on the pivot arm.

Install the pinch bolt [2] and tighten it.

**TORQUE: 27 N·m (2.8 kgf·m, 20 lbf·ft)**

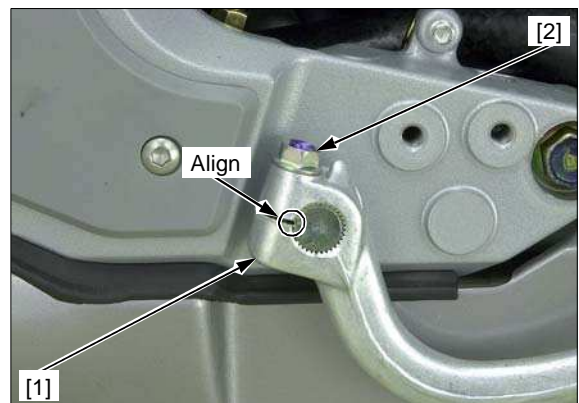

Install the footpeg [1] and tighten the bolts [2].

**TORQUE: 27 N·m (2.8 kgf·m, 20 lbf·ft)**



Apply locking agent to the threads of the switch holder screws.

Install the brake light/cruise cancel switch ('13 - '14 GL1800B: brake light switch) assembly [1] with the screws.

Adjust the switch position so that the brake light comes on when pushing the brake pedal slightly and the push rod moves 0.7 – 1.7 mm.

Tighten the switch holder screws.

**TORQUE: 1.5 N·m (0.2 kgf·m, 1.1 lbf·ft)**

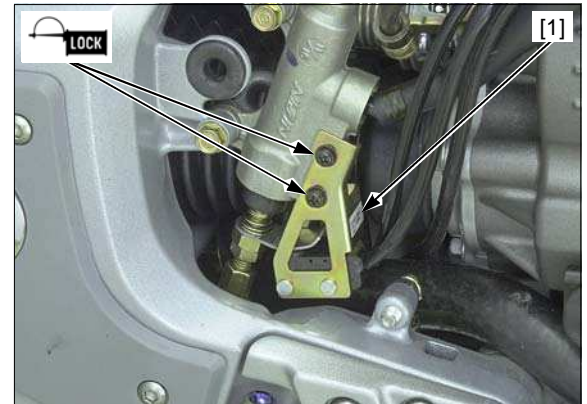

## **REMOVE THE FRONT WHEEL**

Refer to the Service Manual, remove the front wheel.

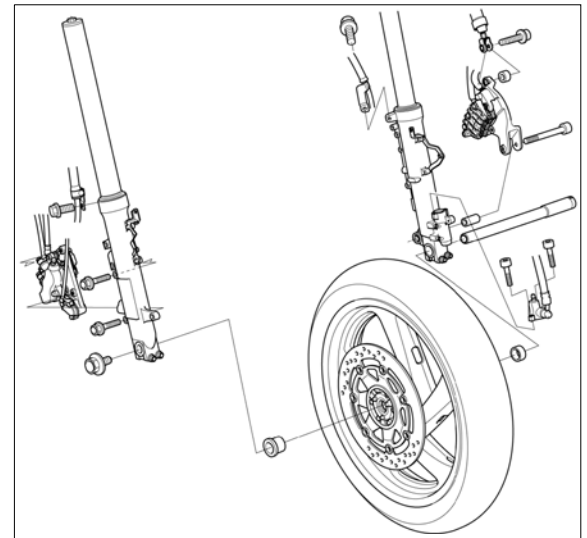

## REMOVE THE SECONDARY MASTER CYLINDER

### REMOVAL

Remove the following:

- oil bolt (upper side) and sealing washers [1]
- upper side brake hose(s) [2]
- brake hose joint attaching bolt [3]

Loosen the oil bolt (front side).

Remove the following:

- mounting bolts [4]
- oil bolt (front side) and sealing washers [5] (discard)
- front side brake hose [6]
- secondary master cylinder [7] (discard)

*When removing the oil bolt, cover the joints of the hoses to prevent contamination.*

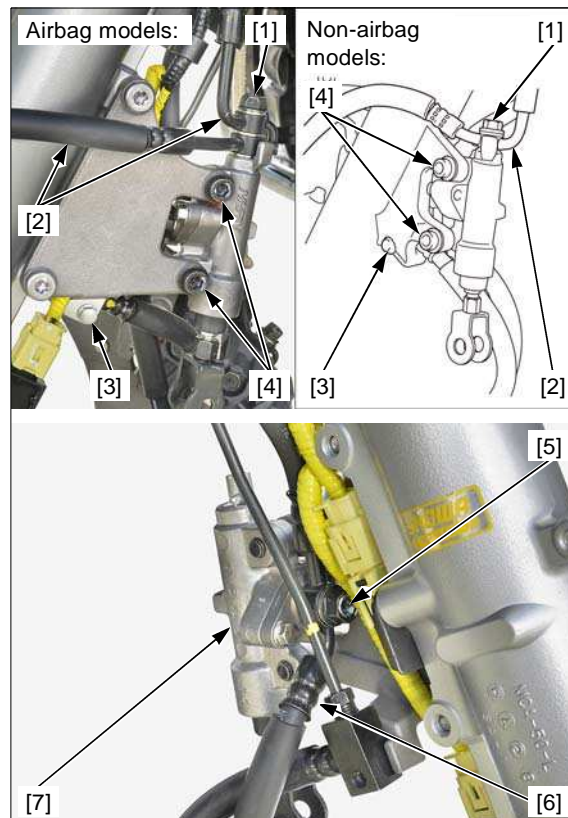

### PLUG THE BRAKE HOSES

Install the washers (reuse), oil bolts [1], and provided cap nuts [2] to the brake hoses as shown.

Tighten the cap nuts securely.

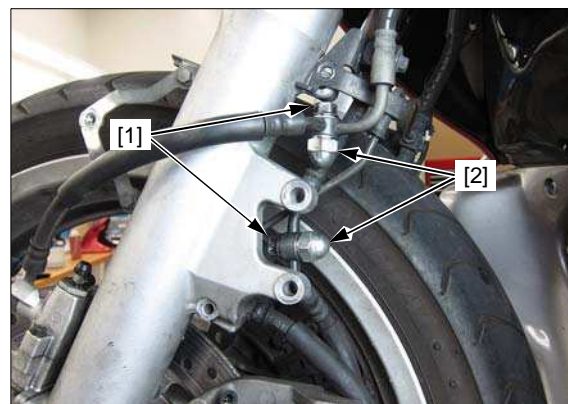

## TEMPORARILY REINSTALL THE FRONT WHEEL

Temporarily reinstall the front wheel and hand tighten the axle nut [1].

Temporarily reinstall the brake calipers and hand tighten the bolts [2].

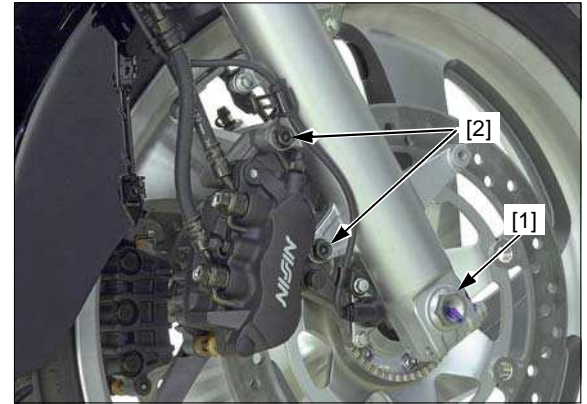

## PEDAL BRAKE LINE FLUID FLUSHING

### FLUID FLUSHING

#### NOTE:

- Use only the provided Pro Honda DOT 4 brake fluid from sealed containers to ensure the quality of the repair procedure.
- It is not a problem if the fluid flowing out of the bleed valve contains air bubbles because the lines will be bled in later steps (AIR BLEEDING).

Fill the reservoir [1] with only Pro Honda DOT 4 brake fluid from a sealed container.

Operate the brake pedal [2] several times until the brake fluid level in the reservoir goes down.



Connect a commercially available brake bleeder to the upper side bleed valve [1] of the left front caliper.

Activate the brake bleeder and loosen the bleed valve.

- Check the reservoir fluid level often while filling the brake to prevent air from being pumped into the system. If air is entering the bleeder from around the bleed valve threads, seal the threads with Teflon tape.

If an automatic refill system is not used, add brake fluid when the fluid level in the reservoir is low.

Repeat above procedure until a sufficient amount of clean fluid flows out of the bleed valve.

Close the bleed valve.

#### NOTE:

- When using a brake bleeding tool, follow the manufacturer's operating instructions.



## GL1800 #23 - REPAIR PROCEDURE

Perform the flushing procedure at each bleed valve in the sequence as follows:

1. Right front caliper lower side bleed valve [2]
2. Rear caliper lower side bleed valve [3]

*Manual pumping is required to ensure all contaminants are removed from the pedal brake line.*

**Manually** pump (no vacuum bleeder) another 200 cc of fluid through each bleed valve in sequence; [1], [2], [3].

- Fill the reservoir to the UPPER level line.
- Pump the fluid through the bleed valve by operating the pedal until the fluid comes down to the LOWER level line.
- Repeat the procedure eight (8) times to pump about 200 cc (approx. 7 oz) through the system.

### NOTE:

Use a graduated cylinder as a catch basin for manual pumping to measure the amount of flushed brake fluid.

Drain the fluid from the system, with the brake bleeder tool, through each bleed valve in sequence; [1], [2], [3].

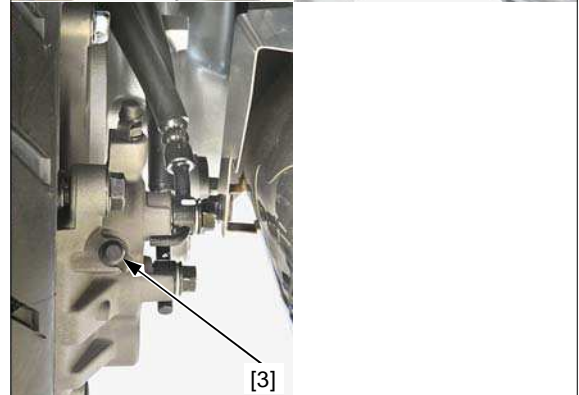
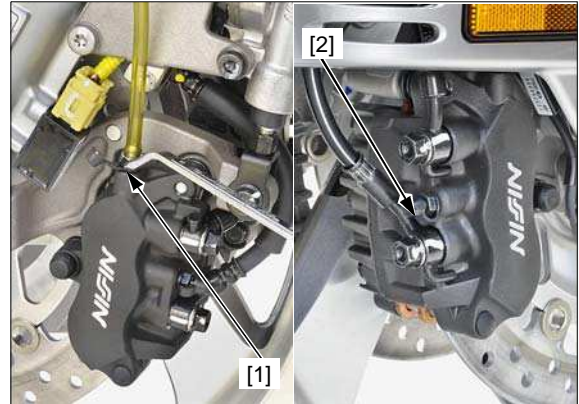

## TEMPORARILY REMOVE THE FRONT WHEEL

Temporarily remove the front brake calipers and front wheel.

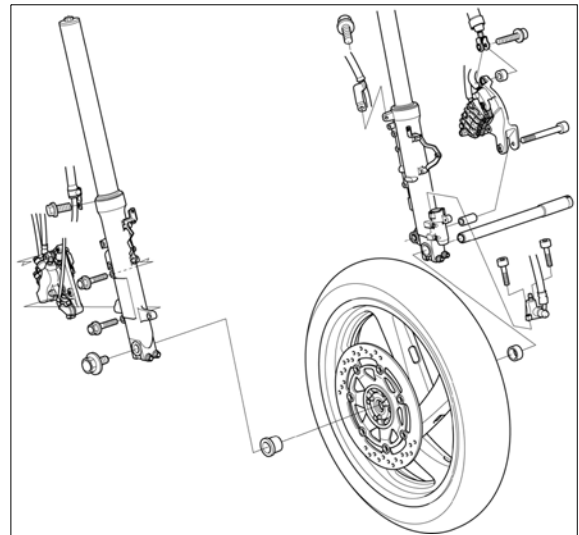

## INSTALL THE NEW SECONDARY MASTER CYLINDER

Remove the cap nuts that were installed on the brake hoses earlier.

Connect the front side brake hose [1] to the master cylinder with the oil bolt [2] and new sealing washers [3].

Install the new secondary master cylinder onto the fork leg with the mounting bolts [4] and tighten them.

**TORQUE: 30 N·m (3.1 kgf·m, 22 lbf·ft)**

Tighten the oil bolt (front side).

**TORQUE: 34 N·m (3.5 kgf·m, 25 lbf·ft)**

Install the brake hose joint and tighten the bolt [5].

**TORQUE: 12 N·m (1.2 kgf·m, 9 lbf·ft)**

Connect the upper side brake hose(s) [6] to the master cylinder with the oil bolt and new sealing washers, and tighten the oil bolt.

**TORQUE: 34 N·m (3.5 kgf·m, 25 lbf·ft)**

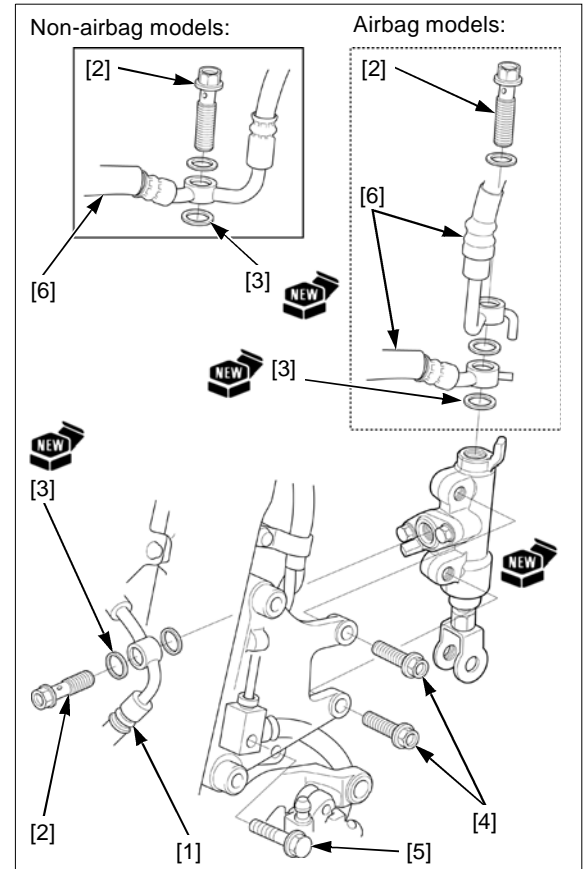

## REINSTALL THE FRONT WHEEL

Refer to the Service Manual, reinstall the front wheel and brake calipers.

Tighten all hardware to the specified torque values.

Do not reinstall the front fender at this time.



## PEDAL BRAKE LINE FLUID FILLING

NOTE:

- Use only the provided Pro Honda DOT 4 brake fluid from sealed containers to ensure the quality of the repair procedure.
- Feed fluid into the pedal brake line in the following sequence:
  1. Left front caliper, upper side bleed valve [1]
  2. Right front caliper, lower side bleed valve [2]
  3. Rear caliper, lower side bleed valve [3]
  4. Anti-dive plunger bleed valve [4]
  5. Rear caliper, upper side bleed valve [5]

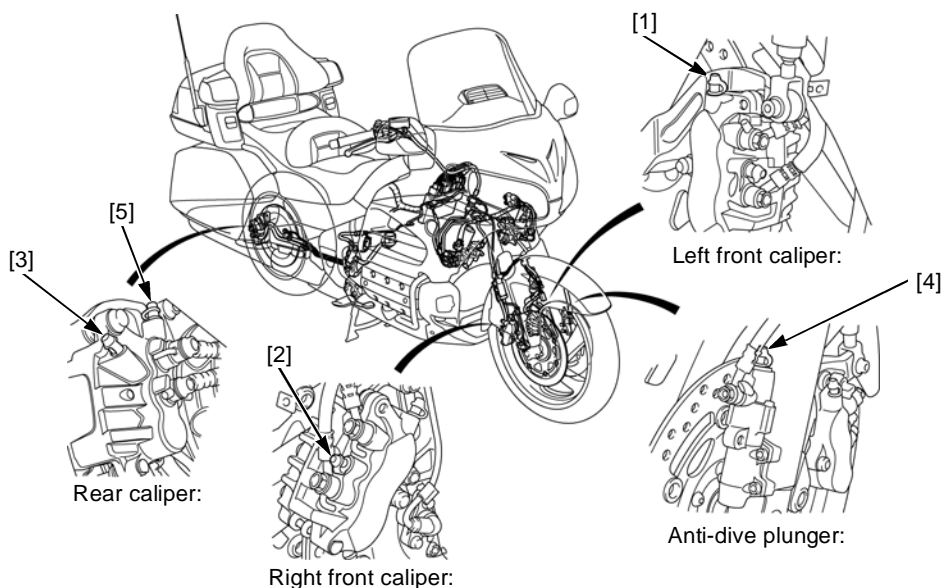

## FLUID FILLING

NOTE:

- It is not a problem if the fluid flowing out of the bleed valve contains air bubbles because the lines will be bled in later steps (AIR BLEEDING).

Fill the reservoir [1] with only Pro Honda DOT 4 brake fluid from a sealed container.

Operate the brake pedal [2] several times until the brake fluid level in the reservoir goes down.





Connect a commercially available brake bleeder to the upper side bleed valve [1] of the left front caliper.

Activate the brake bleeder and loosen the bleed valve.

- Check the reservoir fluid level often while filling the brake to prevent air from being pumped into the system. If air is entering the bleeder from around the bleed valve threads, seal the threads with Teflon tape.

If an automatic refill system is not used, add brake fluid when the fluid level in the reservoir is low.

Repeat the above procedure until a sufficient amount of clean fluid flows out of the bleed valve.

Close the bleed valve.

**NOTE:**

- When using a brake bleeding tool, follow the manufacturer's operating instructions.

Perform the above procedure at each bleed valve in the sequence as follows:

1. Right front caliper lower side bleed valve [2]
2. Rear caliper lower side bleed valve [3]
3. Anti-dive plunger bleed valve [4]
4. Rear caliper upper side bleed valve [5]

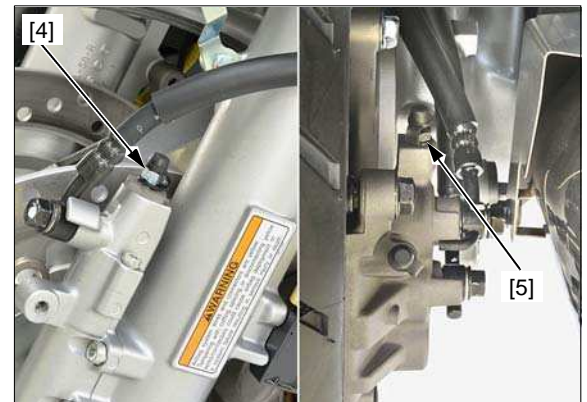

*Manual pumping is required to ensure all contaminants are removed from the pedal brake line.*

**Manually** pump (no vacuum bleeder) another 200 cc (approx 7 oz) of fluid through each bleed valve in sequence:

1. Anti-dive plunger bleed valve [4]
2. Rear caliper upper side bleed valve [5]
  - Fill the reservoir to the UPPER limit line.
  - Pump the fluid through the bleed valve by operating the pedal until the fluid comes down to the LOWER level line.
  - Repeat the procedure eight (8) times to pump about 200 cc (approx. 7 oz) through the system.

**NOTE:**

Use a graduated cylinder as a catch basin for manual pumping to measure the amount of flushed brake fluid.

## PEDAL BRAKE LINE AIR BLEEDING

### MANUAL AIR BLEEDING

NOTE:

- Use only the provided Pro Honda DOT 4 brake fluid from sealed containers to ensure the quality of the repair procedure.
- Note that you may feel strong resistance on the brake pedal during pumping to bleed air from the right front caliper. This is caused by the activation of the delay valve. Be sure to depress the brake pedal fully to the bottom.
- The air bleeding procedure must be performed in the same way as in the fluid filling procedure without using a brake bleeder tool.  
Repeat this procedure until air bubbles no longer appear in the plastic overflow hose at each bleed valve.  
After air bubbles cease to appear in the fluid, repeat the air bleeding procedure 2 to 3 times.
- Make sure that the bleed valves are closed and operate the brake pedal. If it still feels spongy, bleed the system again.
- After bleeding the air completely, tighten the bleed valves.

**TORQUE: 5.4 N·m (0.6 kgf·m, 4.0 lbf·ft)**

Fill the reservoir to the upper level line with only Pro Honda DOT 4 brake fluid from a sealed container. Remove the bolt [1] and reservoir then install the diaphragm [2], set plate [3] and reservoir cap [4] to the reservoir.

Install the reservoir and tighten the bolt securely.

Clean up any spilled brake fluid with soapy water.

Install the following:

- front fender B, both fender covers, and front fender A
- rear fender A



## CHECK THE REPAIR

Confirm that all bleed valves are tight and there are no leaks.

Check the pedal brake operation.

## IDENTIFICATION

After you have completed the entire repair procedure, apply a punch mark on the rear master cylinder lower mounting tab as shown.

Install the right engine side cover.

